

It is a Four-Channel Pluggable, LC Duplex, Fiber-Optic QSFP+ Transceiver for 40 Gigabit Ethernet Applications. This transceiver is a high-performance module for short-range duplex data communication and interconnect applications. It integrates four electrical data lanes in each direction into transmission over a single LC duplex fiber optic cable. Each electrical lane operates at 10.3125 Gbps and conforms to the 40GE XLPPi interface.

The transceiver internally multiplexes an XLPPi 4x10G interface into two 20Gb/s electrical channels, transmitting and receiving each optically over one simplex LC fiber using bi-directional optics. This results in an aggregate bandwidth of 40Gbps into a duplex LC cable. This allows reuse of the installed LC duplex cabling infrastructure for 40GbE application. Link distances up to 100 m using OM3 and 150m using OM4 optical fiber are supported. These modules are designed to operate over multimode fiber systems using a nominal wavelength of 850nm on one end and 900nm on the other end. The electrical interface uses a 38 contact QSFP+ type edge connector. The optical interface uses a conventional LC duplex connector.



Features

- Compliant to the 40GbE XLPPi electrical specification per IEEE 802.3ba-2010
- Operates at 10.3125 Gbps per electrical channel with 64b/66b encoded data
- QSFP MSA compliant
- Capable of over 100m transmission on OM3 Multimode Fiber (MMF) and 150m on OM4 MMF
- Temperature range 0°C to 70°C
- RoHS Compliant Part
- Utilizes a standard LC duplex fiber cable allowing reuse of existing cable infrastructure

Applications

- 40 Gigabit Ethernet interconnects
- Datacom/Telecom switch & router connections
- Data aggregation and backplane applications
- Proprietary protocol and density applications

General Specifications

ITEM	DETAIL
Speed	40 Gb/s
Optical Connector	Dual LC
Operating distance	100 m OM3 and 150 m OM4
Power Supply	Single 3.3 V
Fiber Type	Multimode 50/125 µm, two strands
Wavelength	850 nm, 900 nm
Compliance	QSFP+ SFF-8436
Digital Diagnostic	Yes

PART NUMBER	DESCRIPTION
SSF-QSFP-40GSR2	40Gb/s 100m QSFP+, Bi-Di, Duplex LC, Hot Pluggable, 850/900nm, VCSEL, Multimode

Transceiver Block Diagram

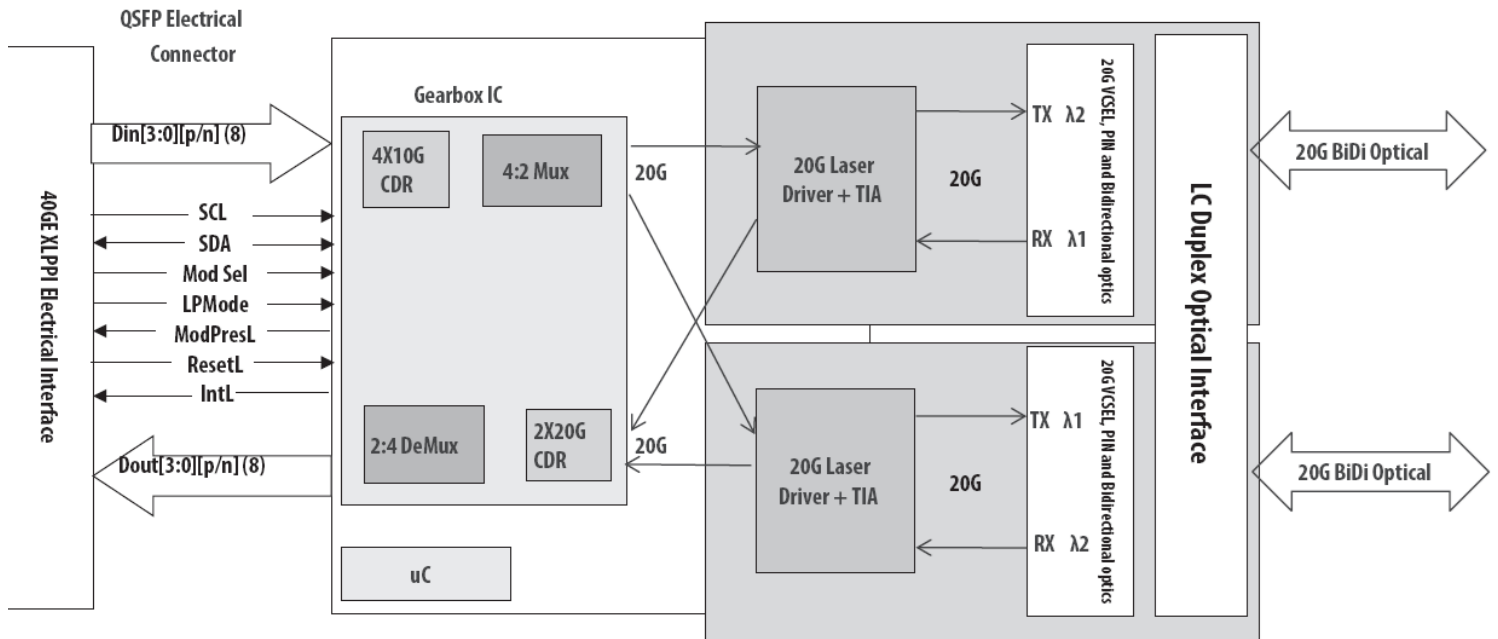

General Specifications

PARAMETER	SYMBOL	MIN.	TYPICAL	MAX.	UNIT
Storage Temperature	T_s	-40		+85	°C
Supply Voltage	$V_{cc,T,R}$	-0.5		4	V
Relative Humidity	RH	0		85	%

Recommended Operating Environment:

PARAMETER	SYMBOL	MIN.	TYPICAL	MAX.	UNIT
Case Operating Temperature	T_c	0		+70	°C
Supply Voltage	$V_{cc,T,R}$	+3.13	3.3	+3.47	V
Supply Current	I_{cc}			1000	mA
Power Dissipation	PD			3.5	W

Electrical Characteristics ($T_{OP} = 0$ to 70 °C, $V_{CC} = 3.13$ to 3.46 Volts)

PARAMETER	SYMBOL	MIN.	TYPICAL	MAX.	UNIT	NOTE
Data Rate per Channel		-	10.3125	11.2	Gbps	
Power Consumption		-	2.5	3.5	W	
Supply Current	I_{cc}		0.75	1.0	A	
Control I/O Voltage-High	V_{IH}	2.0		V_{CC}	V	
Control I/O Voltage-Low	V_{IL}	0		0.7	V	
Inter-Channel Skew	TSK			150	Ps	
RESETL Duration			10		Us	
RESETL De-assert time				100	ms	
Power On Time				100	ms	

Transmitter						
Single Ended Output Voltage Tolerance		0.3		4	V	1
Common mode Voltage Tolerance		15			mV	
Transmit Input Diff Voltage	V_I	120		1200	mV	
Transmit Input Diff Impedance	Z_{IN}	80	100	120		
Data Dependent Input Jitter	DDJ			0.1	UI	
Data Input Total Jitter	TJ			0.28	UI	

Receiver						
Single Ended Output Voltage Tolerance		0.3		4	V	1
Rx Output Diff Voltage	Vo		600	800	mV	
RX Output Rise and Fall Voltage	Tr/Tf			35	ps	1
Total Jitter	TJ			0.7	UI	
Deterministic Jitter	DJ			0.42	UI	

Optical Parameters (TOP = 0 to 70 °C, VCC = 3.0 to 3.6 Volts)

PARAMETER	SYMBOL	MIN.	TYPICAL	MAX.	UNIT	REF.
Transmitter						
Optical Wavelength CH1	λ	832	850	868	nm	
Optical Wavelength CH2	λ	882	900	918	nm	
RMS Spectral Width	Pm		0.5	0.65	nm	
Average Optical Power per Channel	Pavg	-4	02.5	+5.0	dBm	
Laser Off Power Per Channel	Poff			-30	dBm	
Optical Extinction Ratio	ER	3.5			dB	
Relative Intensity Noise	Rin			-128	dB/HZ	1
Receiver						
Optical Center Wavelength CH1	λ	882	900	918	nm	
Optical Center Wavelength CH2	λ	832	850	868	nm	
Receiver Sensitivity per Channel	R		-11		dBm	
Maximum Input Power	Pmax	+0.5			dBm	
Receiver Reflectance	Rrx			-12	dB	
LOS De-Assert	LOS _D			-14	dBm	
LOS Assert	LOS _A	-30			dBm	
LOS Hysteresis	LOS _H	0.5			dB	

Optical Parameters (TOP = 0 to 70 °C, VCC = 3.0 to 3.6 Volts)

PARAMETER	SYMBOL	MAX.	UNIT	CONDITIONS
Initialization Time	t_init	2000	ms	Time from power on1, hot plug or rising edge of reset until the module is fully functional
Reset Init Assert Time	t_reset_init	2	µs	A Reset is generated by a low level longer than the minimum reset pulse time present on the ResetL pin.
Serial Bus Hardware Ready Time	t_serial	2000	ms	Time from power on1 until module responds to data transmission over the 2-wire serial bus
Monitor Data Ready Time	t_data	2000	ms	Time from power on1 to data not ready, bit 0 of Byte 2, deasserted and IntL asserted
Reset Assert Time	t_reset	2000	ms	Time from rising edge on the ResetL pin until the module is fully functional2
LPMODE Assert Time	ton_LPMODE	100	µs	Time from assertion of LPMODE (Vin:LPMODE = Vih) until module power consumption enters lower Power Level
IntL Assert Time	ton_IntL	200	ms	Time from occurrence of condition triggering IntL until Vout:INTL = Vol
IntL De-assert Time	toff_IntL	500	µs	toff_IntL 500 µs Time from clear on read3 operation of associated flag until Vout:INTL = Voh. This includes deassert times for Rx LOS, Tx Fault and other flag bits.
Rx LOS Assert Time	ton_los	100	ms	Time from RX LOS state to Rx LOS bit set and IntL asserted
Flag Assert Time	ton_flag	200	ms	Time from occurrence of condition triggering flag to associated flag bit set and IntL asserted
Mask Asser Time	ton_mask	100	ms	Time from mask bit set4 until associated IntL assertion is inhibited
Mask De-assert Time	toff_mask	100	ms	Time from mask bit cleared4 until associated IntL operation resumes
ModSelL Assert Time	ton_ModSelL	100	µs	Time from assertion of ModSelL until module responds to data transmission over the 2-wire serial bus
ModSelL De-assert Time	toff_ModSelL	100	µs	Time from deassertion of ModSelL until the module does not respond to data transmission over the 2-wire serial bus
Power_over-ride or Power-set Assert Time	ton_Pdown	100	ms	Time from P_Down bit set 4 until module power consumption enters lower Power Level
Power_over-ride or Power-set De-assert Time	toff_Pdown	300	ms	Time from P_Down bit cleared4 until the module is fully functional3

Pin Assignment

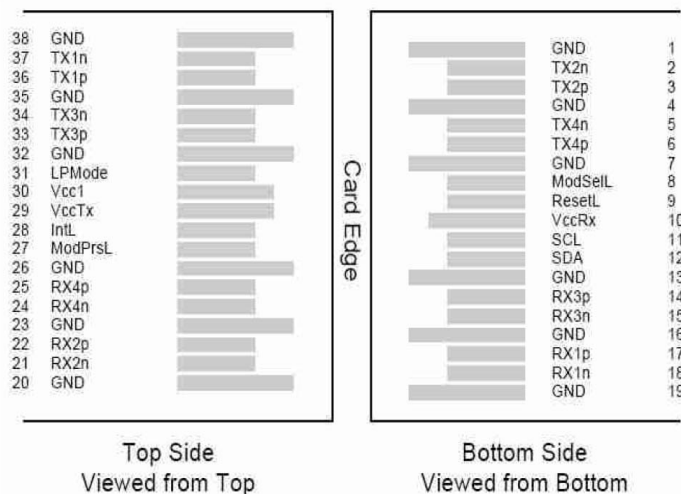

Pin Description

PIN	LOGIC	SYMBOL	NAME/DESCRIPTION	REF.
1		GND	Ground	1
2	CML-I	Tx2n	Transmitter Inverted Data Input	
3	CML-I	Tx2p	Transmitter Non-Inverted Data ouput	
4		GND	Ground	1
5	CML-I	Tx4n	Transmitter Inverted Data Ouput	
6	CML-I	Tx4p	Transmitter Non-Inverted Data Output	
7		GND	Ground	1
8	LVTTL-I	ModSelL	Module Select	
9	LVTTL-I	ResetL	Module Reset	
10		VccRx	+3.3 V Power Supply Receiver	2
11	LVC MOS-I/O	SCL	2-Wire Serial Interface Clock	
12	LVC MOS-I/O	SDA	2-Wire Serial Interface Data	
13		GND	Ground	1
14	CML-O	Rx3p	Receiver Inverted Data Ouput	
15	CML-O	Rx3n	Receiver Non-Inverted Data Ouput	
16		GND	Ground	1

Pin Description Cont.

PIN	LOGIC	SYMBOL	NAME/DESCRIPTION	REF.
17	CML-O	Rx1p	Receiver Inverted Data Ouput	
18	CML-O	Rx1n	Receiver Non-Inverted Data Ouput	
19		GND	Ground	1
20		GND	Ground	1
21	CML-O	Rx2n	Receiver Inverted Data Ouput	
22	CML-O	Rx2p	Receiver Non-Inverted Data Ouput	
23		GND	Ground	1
24	CML-O	Rx4n	Receiver Inverted Data Ouput	
25	CML-O	Rx4p	Receiver Non-Inverted Data Ouput	
26		GND	Ground	1
27	LVTTTL-O	ModPrsL	Module Present	
28	LVTTTL-O	IntL	Interrupt	
29		VccTx	+3.3 V Power Supply Transmitter	2
30		Vcc1	+3.3 V Power Supply	2
31	LVTTTL-I	LPMoDe	Low Power Mode	
32		GND	Ground	1
33	CML-I	Tx3p	Transmitter Inverted Data Output	
34	CML-I	Tx3n	Transmitter Non-Inverted Data Ouput	
35		GND	Ground	1
36	CML-I	Tx1p	Transmitter Inverted Data Output	
37	CML-I	Tx1n	Transmitter Non-Inverted Data Output	
38		GND	Ground	1

Notes:

1. GND is the symbol for single and supply(power) common for QSFP modules, All are common within the QSFP module and all module voltages are referenced to this potential otherwise noted. Connect these directly to the host board signal common ground plane. Laser output disabled on TDIS >2.0V or open, enabled on TDIS <0.8V.
2. VccRx, Vcc1 and VccTx are the receiver and transmitter power suppliers and shall be applied concurrently. Recommended host board power supply filtering is shown below. VccRx, Vcc1 and VccTx may be internally connected within the QSFP transceiver module in any combination. The connector pins are each rated for maximum current of 500mA.

Recommended Circuit

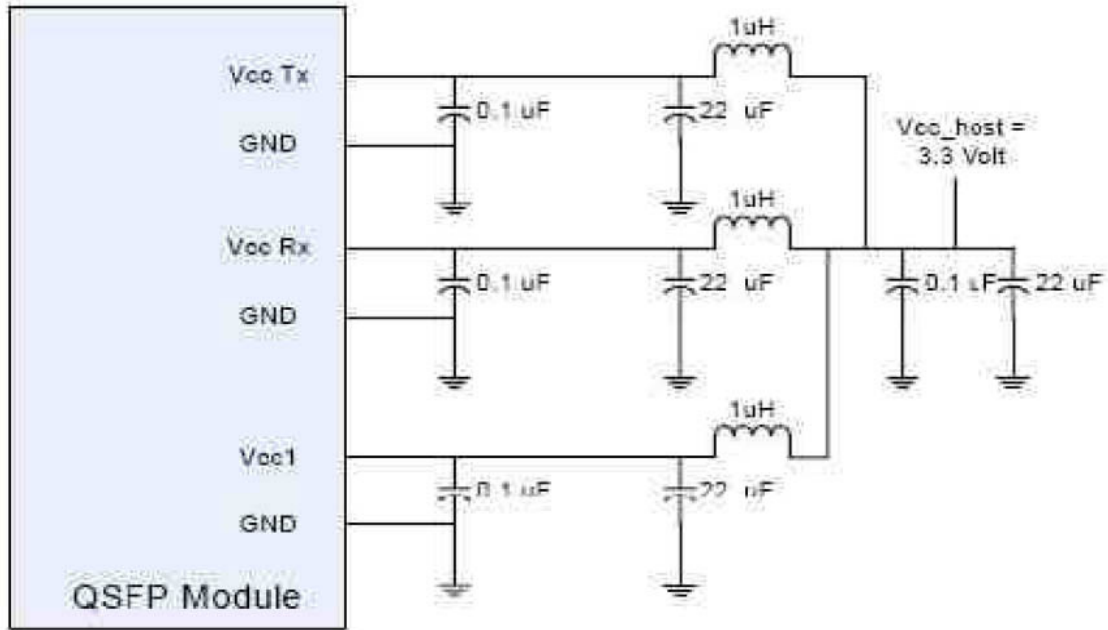

Recommended Circuit

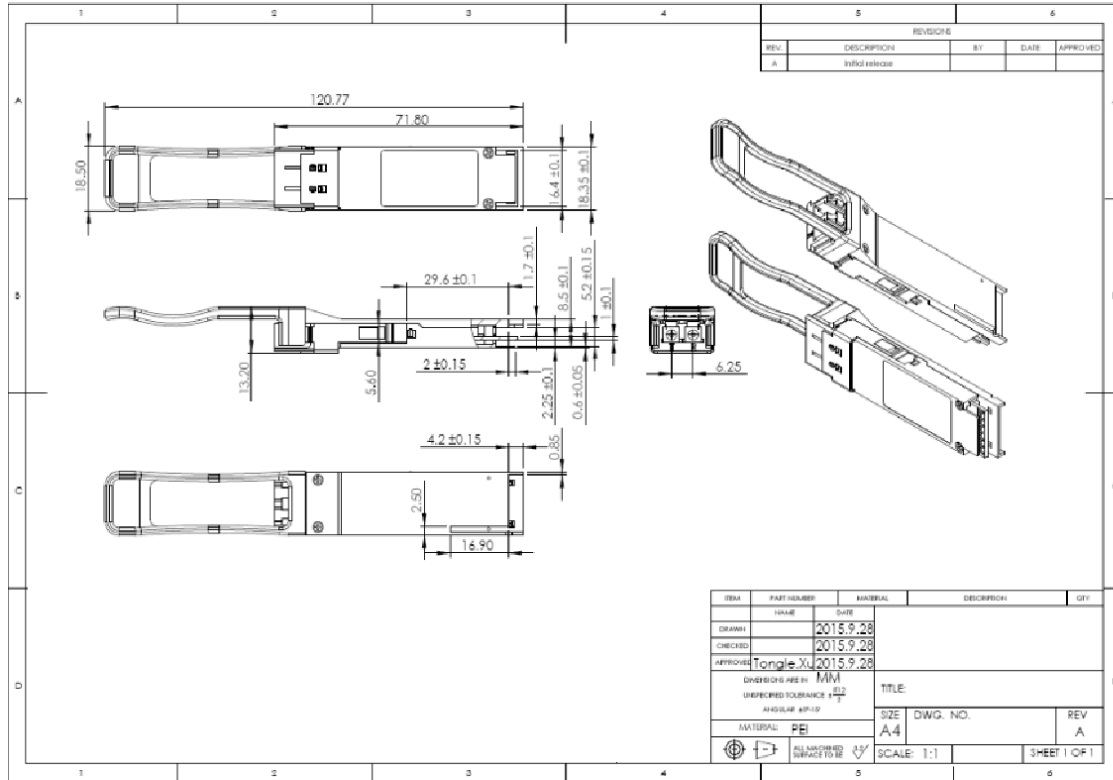

NOTE:
 QSFP-40G-SR-BD optical modules cannot be used for stack connection and do not support the digital diagnostic monitoring (DDM) function.