

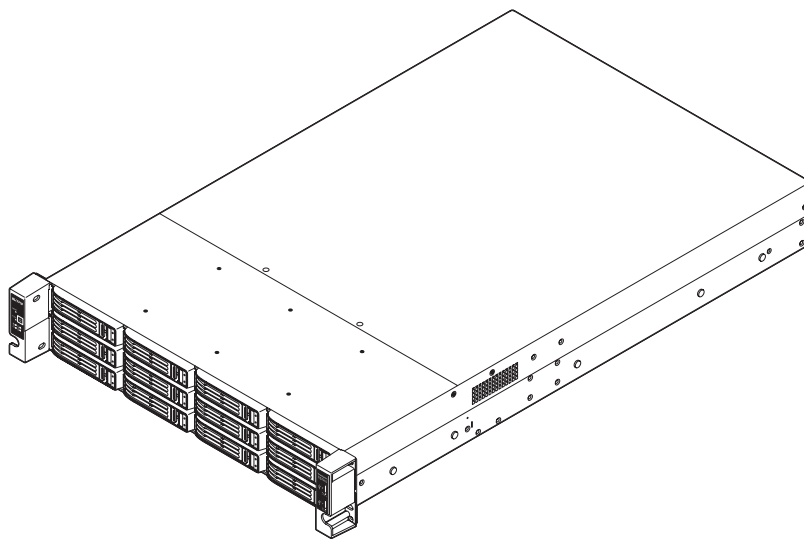

**Network Attached Storage
TeraStation 7010**

User Manual



Please make sure to read this manual before using and follow the procedures. If you have any inquiries about the product, contact the number on the warranty statement or the packing box. Do not discard the included documents, the warranty statement, or the packing box.

www.buffaloamericas.com

35022631-09
December 2024

Table of Contents

Chapter 1 Notice	10
Regulatory Compliance Information.....	10
Warning Symbols and Graphical Icons on the Product.....	10
Safety Precautions	10
Chapter 2 Hardware Components.....	12
Diagrams.....	12
Installing and Uninstalling Expansion Cards.....	14
Adding an Expansion Card.....	14
Removing an Expansion Card	17
Installing or Uninstalling Memory Modules	19
Adding a Memory Module	19
Removing a Memory Module.....	21
Chapter 3 Getting Started	24
Turning the TeraStation On and Off.....	24
Creating a USB Initialization Drive	24
Accessing Settings	24
Opening Settings.....	24
Configuring Settings via Setup Wizard	27
Checking the Device Information from Dashboard	28
Shutting Down or Restarting the TeraStation from Settings	29

Chapter 4 File Sharing 30

Configuring Shared Folders	30
Adding a Shared Folder	30
Recycle Bin.....	32
Read-Only Shares.....	32
Hidden Shares	33
Configuring Users	33
Adding a User	33
Importing User Information.....	36
Adding a Group	36
Configuring Access Restrictions	39
Restricting Local User Access to Shared Folders	39
Restricting AD Domain User Access to Shared Folders.....	41
Restricting Access to Subfolders	44
Improving File Access Speed Using SMB Multichannel	46
Enhancing Compatibility for macOS Client Access	47
NFS	48
Enabling NFS	48
NFS Mount Commands	52
Offline Files for Windows.....	52

Chapter 5 RAID Modes and Drive Management 55

Available RAID Modes	55
Working with RAID Arrays	56
Using JBOD	56
Creating a RAID Array	57
Shutting Down the TeraStation Automatically If an Error Occurs.....	59

Rebuilding the RAID Array Automatically	60
Configuring Actions for If a Drive Used for the RAID Array Has Not Been Detected	61
Configuring a Hot Spare.....	63
Managing a RAID Array Without Deleting Data	65
RAID Scanning.....	70
Configuring Low Drive Space Alerts	71
Storage Balancing	72
Adding an External Drive	74
Dismounting Drives	75
Checking Drives	76
S.M.A.R.T.	77
Displaying S.M.A.R.T. Information	78
Checking the Drive Condition.....	79
Formatting Drives	79
Encrypting Drives.....	81
Erasing Data on the TeraStation Completely	81
Performing a Full Format	81
Performing the Secure Erase Command	82
Quotas.....	84
Limits for Shared Folders	84
Limits for LVM Volumes	85
Using the TeraStation as an iSCSI Device	88
Introduction	88
Creating an iSCSI Volume	89
Connecting Volumes.....	91
Formatting Volumes	92
Disconnecting Volumes.....	92

Configuring Access Restrictions	93
Connecting Access-Restricted Volumes	95
Expanding Volume Capacity	96
Deleting Volumes.....	98
Enabling the iSNS Protocol	99
Advanced iSCSI Volume Settings.....	99
Increasing File Access Speeds Using SSD Caching	100
Creating an SSD Cache	100
Deleting an SSD Cache	102

Chapter 6 Backup 104

Snapshots	104
Overview	104
Application for iSCSI Volume Snapshots	104
Manually Creating a Snapshot.....	104
Accessing the Snapshots via SMB.....	108
Restoring Snapshots.....	110
Configuring Schedule Snapshot.....	114
Configuring Snapshot Archive Settings.....	117
Backing Up Data on the TeraStation.....	124
Backup Modes.....	125
Preparing a Backup Destination.....	128
Configuring a Backup Job	130
If Backing Up from rsync-Compatible Devices to the TeraStation	135
Restoring Backup Data	136
Backup Logs for If Backup Fails	140
Replication.....	143
Preparing a Replication Destination	144
Configuring a Replication Job	146

Synchronizing Between Source and Destination TeraStations Periodically	149
Failover	150
Before Configuring Failover	151
Usage Restrictions	152
Configuring Failover	152
Changing Settings While Failover Is Configured	155
Maintenance Mode	155
Synchronizing Between Main and Backup TeraStations Periodically	159
Switching to the Backup TeraStation Manually	160
Reconfiguring After Failover Occurs	161
Stopping Failover	163
Backing Up Your Mac with Time Machine	165

Chapter 7 Cloud Services and Remote Access..... 172

Synchronizing with Amazon S3-Compatible Storage	172
Creating an Amazon S3 Job	172
Uploading Files to Amazon S3	175
Synchronizing with Box	179
Creating a Box Storage Sync Job	179
Changing Job Settings	190
Corrective Actions for in Case of Error	191
Synchronizing with Dropbox	193
Creating a Dropbox Sync Job	193
Changing Job Settings	196
Creating a Shared Link (Windows Only)	199
Using Microsoft Azure for Data Preservation	199
Creating an Azure Storage Sync Backup Job	199
Creating an Azure Storage Sync Restore Job	207

Changing Job Settings	212
Synchronizing with Microsoft OneDrive	214
Creating a OneDrive Sync Job.....	214
Changing Job Settings	225
Corrective Actions for in Case of Error	226
WebAccess	228
Configuring WebAccess	228
Accessing via WebAccess.....	231
Unable to Successfully Configure WebAccess	232
FTP.....	233
Enabling FTP	233
Accessing the TeraStation with an FTP Client.....	234

Chapter 8 Security Enhancement..... 236

Two-Factor Authentication	236
Enabling Two-Factor Authentication	236
Restricting Logins for Non-Admin Users.....	241
Disabling Two-Factor Authentication	243
Encrypting Data Transmission	245
Encrypting Settings Data	245
Encrypting FTP Transfer Data	246
SSL.....	246
FIPS Mode	247

Chapter 9 Settings Backup/Restoration 249

Saving and Applying Settings.....	249
Saving Settings	250
Applying Settings	250

Transferring Another Buffalo NAS Device's Settings	251
Creating a Config File (.nas_config).....	252
Transferring Settings.....	252
Restoring Factory Defaults.....	253
Initializing from Settings	253
Initializing Using the USB Initialization Drive	254
Resetting the Administrator Password	255

Chapter 10 Network Settings **257**

Wake-on-LAN	257
Port Trunking.....	257
SNMP	260
Proxy Server	262
Jumbo Frames	263
Changing the IP Address	264
Mapping IP Address and Hostname	266

Chapter 11 Advanced Features **268**

Email Notification	268
Enabling Email Notification	268
Changing Events for Email Reports.....	269
Sleep Mode	270
UPS (Uninterruptible Power Supply)	274
One Power Supply Unit Is Installed	274
Two Power Supply Units Are Installed	275
Automatic Shutdown If Power Supply Fails	277

Logs	279
Displaying TeraStation's Logs	279
Transferring Logs to the Syslog Server	280
Creating a Shortcut to the Logs in the Shared Folder	280
Changing Archive Rules for File Access Logs	281
Updating the Firmware.....	282
Updating Manually Using Settings	282
Enabling Automatic Update.....	283
Configuring Update Notification.....	284
Name, Date, Time, and Language	285
Beep Alerts	287
LEDs.....	288

Chapter 12 Drive Replacement and Device

Troubleshooting 290

Replacing a Defective Drive	290
Drive Replacement for a Redundant RAID Array.....	290
Drive Replacement for a RAID 0 Array	292
Drive Replacement for a JBOD.....	292
Drive Replacement for a Hot Spare	293
Replacing a Non-Malfunctioning Drive.....	293
Re-Inserting Drives	294
TeraStation Does Not Work Properly	295
Power LED Keeps Blinking	295
Booting the TeraStation in Emergency Mode.....	296
Unable to Access Shared Folders	297
Opening the Network Credentials Window	297
Restoring Owner and Permission Settings	297

Configuring Compatible SMB Protocols299

Chapter 13 Utilities..... 301

NAS Navigator2 301
 Windows301
 macOS.....301
NovaBACKUP 301

Chapter 14 Appendix 302

Info and Error LEDs 302
 Errors.....302
 Alerts.....303
 Information Events304
Default Settings 306
Specifications 307

Chapter 1 Notice

Regulatory Compliance Information







For Customers in the United States

This device complies with Part 15 of the FCC Rules. Operation is subject to the following two conditions: (1) this device may not cause harmful interference, and (2) this device must accept any interference received, including interference that may cause undesired operation.

This equipment has been tested and found to comply with the limits for a Class A digital device, pursuant to part 15 of the FCC Rules. These limits are designed to provide reasonable protection against harmful interference when the equipment is operated in a commercial environment. This equipment generates, uses, and can radiate radio frequency energy and, if not installed and used in accordance with the instruction manual, may cause harmful interference to radio communications. Operation of this equipment in a residential area is likely to cause harmful interference in which case the user will be required to correct the interference at his own expense.

Warning Symbols and Graphical Icons on the Product

Warning symbols are used on the product for safety operation and prevention of injury to you and damage to the unit. The following explains the meanings of symbols used on the product.

Icon	Meaning
	This symbol indicates important warnings or cautions for operation and maintenance. Additional information will follow this symbol.
	This symbol indicates the presence of an alternating current.
	This symbol indicates that the equipment may carry risk of electric shock.
	This symbol indicates danger of hazardous high voltage.
	This symbol indicates a protective earthing terminal.
	This symbol indicates that the protective conductor should be connected first to the protective earthing terminal.
	This symbol indicates that the rack-mounted equipment should not be used for a shelf or a work space.

Safety Precautions

Before using your device, basic safety instructions should always be followed.

- (1) Read these instructions.
- (2) Keep these instructions.
- (3) Heed all warnings and follow all instructions.

- (4) The device can only be used in a fixed location, such as a telecommunication center or a dedicated computer room. When you install the device, ensure that the protective earthing connection of the socket-outlet is verified by a technician.
- (5) The socket-outlet shall be installed near the equipment and shall be easily accessible.
- (6) Only use the cables and accessories that are included in the package. Don't use other accessories or cables unless specifically instructed to in the documentation.



- (7) **Caution:** Slide/rail mounted equipment is not to be used as a shelf or a work space.



- (8) **Caution:** Do not replace the battery. There is risk of explosion if the battery is replaced with one that is an incorrect type.



- (9) Do not ingest battery in case of a chemical burn hazard. This product contains a coin/button cell battery. If the battery is swallowed, it can cause severe internal burns within 2 hours and may lead to death. If you think batteries might have been swallowed or placed inside any part of the body, seek immediate medical attention.



- (10) High touch current. Connect to earth before connecting to supply.



- (11) **Caution:** Be careful not to injure fingers when handling. Open or close the cover after powering off the device and unplugging the power cable.

Chapter 2 Hardware Components

Diagrams

TS71210RH

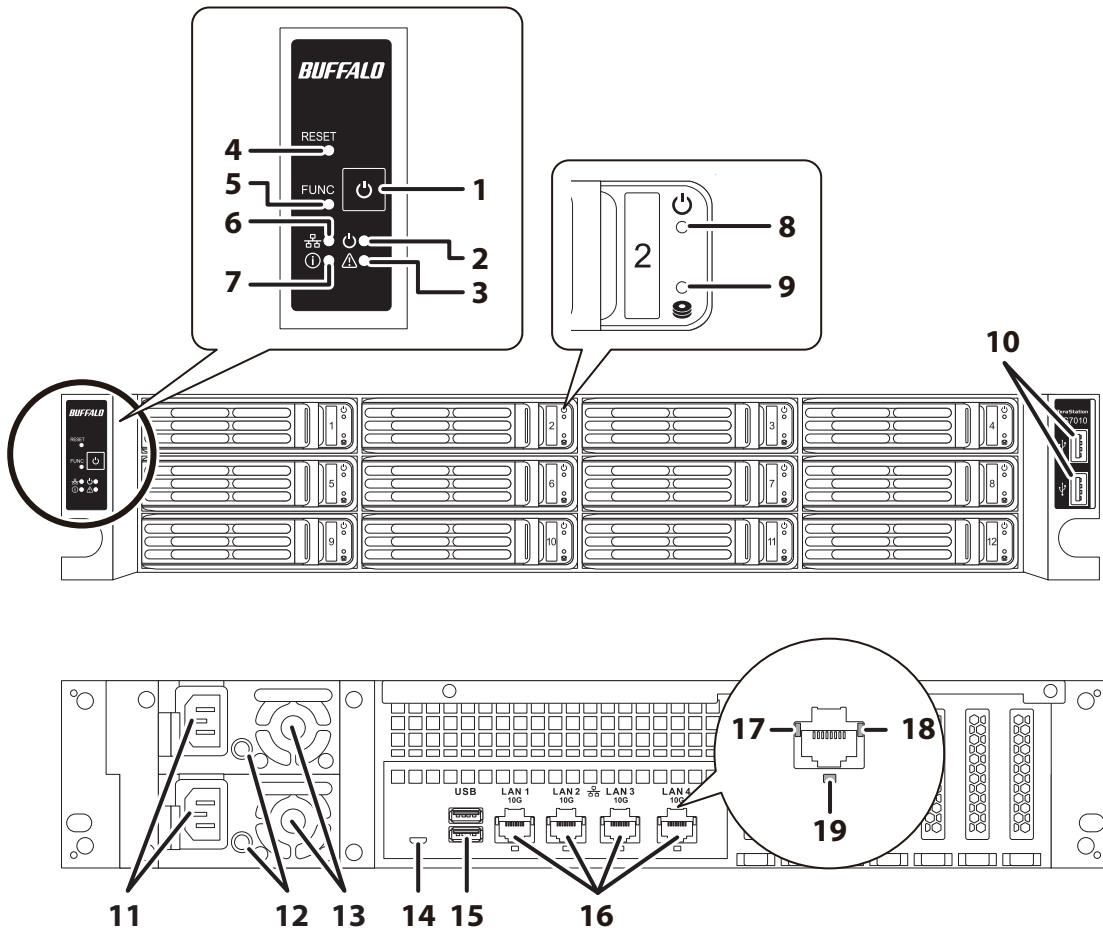

1 Power Button

Press this button to power on and off the TeraStation. If the TeraStation beeps, pressing and holding this button for a short period will stop the beeping.

2 Power LED

Glows green when the TeraStation is on.

Note: If the LED continues to blink for longer than 15 minutes instead of turning into a solid glow, refer to the [“Power LED Keeps Blinking”](#) section in chapter 12 for more details.

3 Error LED

If there is an error, the error LED will glow red. Check the Dashboard or NAS Navigator2 to see the error message.

Note: The error LED will be extinguished if the TeraStation is powered off.

4 Reset Button

Press and hold down this button with something pointed to reset the TeraStation's admin username and password, "powerusers" group privileges*, two-factor authentication settings, IP settings other than Wake-on-LAN, port trunking, SSL, and service port restriction settings to their factory default values. The effects of this button can be changed in Settings.

During initialization, the TeraStation will beep and the I23 message will appear as a notification. When initialization finishes, the I23 message will disappear.

*For more detailed information on reset privileges, refer to the "[Resetting the Administrator Password](#)" section in chapter 9.

5 Function Button

Use this button for rebuilding RAID arrays, configuring failover, stopping the TeraStation's beeping, and initializing settings using a USB drive.

6 LAN LED

When any LAN ports are connected, this LED glows blue.

7 Info LED

If there is a status message, the info LED will glow amber. Check the Dashboard or NAS Navigator2 to see the status message.

8 Drive Status LED

Glow blue when a drive is detected. It blinks when the drive is accessed.

9 Drive Error LED

Normally, this LED is extinguished. If a drive fails, its LED will turn red.

10 USB 2.0 Port

Compatible USB UPS devices can be connected. USB drives and USB hubs are not supported.

11 Power Connector

Use the included power cable to connect to a UPS, surge protector, or outlet.

12 Beep Off Button (for Power Supply Unit)

If a power supply error occurs or the power cable is disconnected (even while the TeraStation is off), you will hear the beep from the TeraStation. To stop beeping, press this button.

13 Fan (for Power Supply Unit)

Spins to prevent overheating inside. Do not block the fan.

14 Factory use only.

15 USB 3.2 Gen 1 Port

Compatible USB drives, USB memory devices, and USB UPS devices can be connected. USB hubs are not supported.

16 LAN Port (10GbE)

Connect an Ethernet cable to use this port for your network. It is available for communicating at max. 10 Gbps if using the included Ethernet or category 6A cable.

Note: To communicate at up to 10 Gbps, all connected network devices must be compatible with 10GbE.

17 Link LED

Glows green when the TeraStation is connected to a network at 10 Gbps and amber when the TeraStation is connected to a network at 1000 Mbps.

18 Link/Act LED

Glows green when the TeraStation is connected to a network. It blinks when the connection is experiencing activity.

19 Not in use.

Installing and Uninstalling Expansion Cards

You can install a PCIe expansion card, which allows you to add an SSD card and enable SSD caching to enhance TeraStation performance, or a network card to increase the number of network ports or support high-speed SFP+ or QSFP network adapters.

Note: There are two PCIe slots on this TeraStation, which enable connecting one SSD card and one network card each. Two SSD cards or two network cards cannot be connected at the same time.

Adding an Expansion Card

Follow the procedure below to add an expansion card. Once the SSD card has been installed, refer to the [“Increasing File Access Speeds Using SSD Caching”](#) section in chapter 5 to configure SSD caching.

- 1** Power off the TeraStation and unplug the power cables from the unit.
- 2** Remove the screws on the sides and back of the TeraStation.

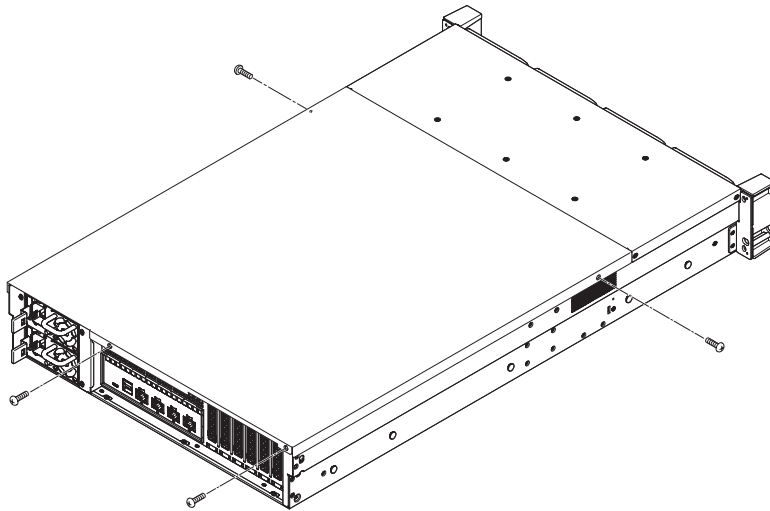

3 Slide the rear top cover to the back side and lift it up to remove it from the TeraStation.

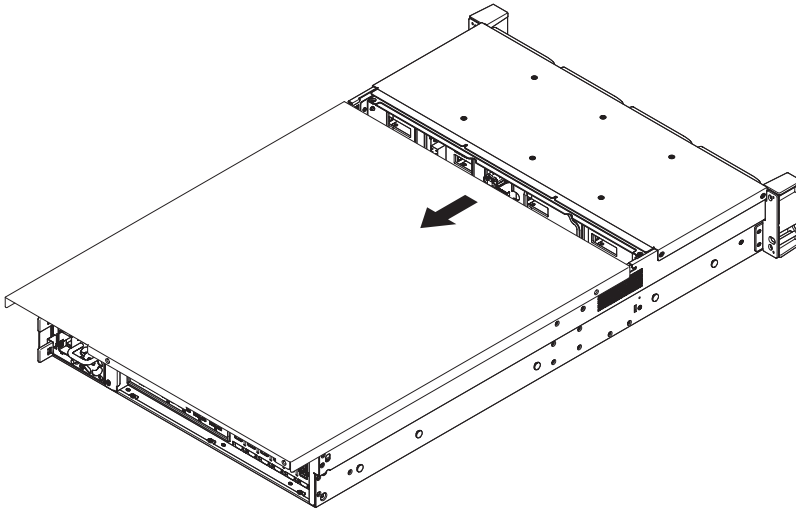

4 Remove the screw of the PCIe slot cover and pull the cover off.

Note: Keep the PCIe slot cover and screw in case you will stop using SSD caching.

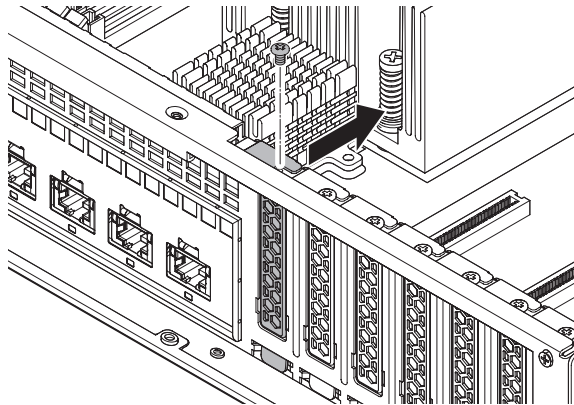

5 Insert the expansion card into the slot.

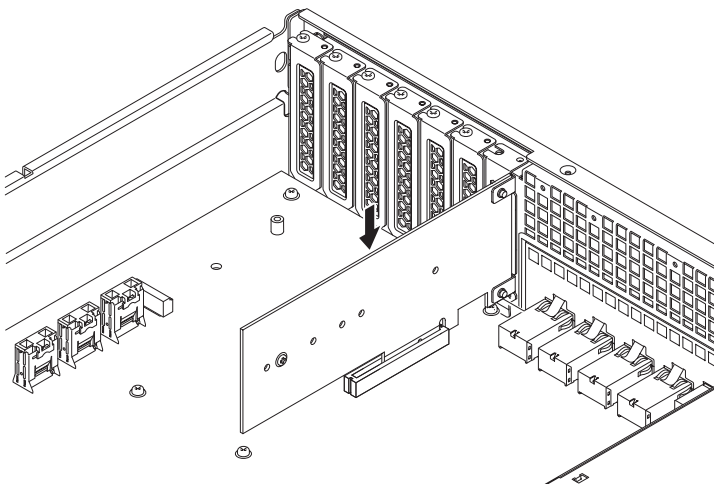

6 Secure the card using the screw that had been removed at step 4.

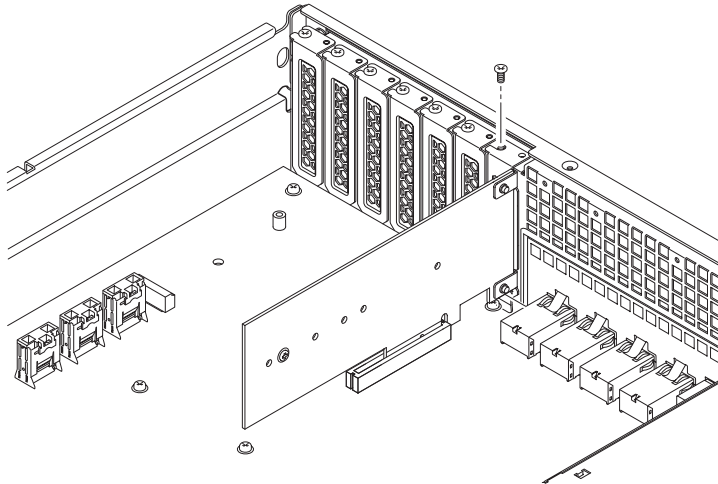

7 Return the rear top cover back and slide it into the secure position.

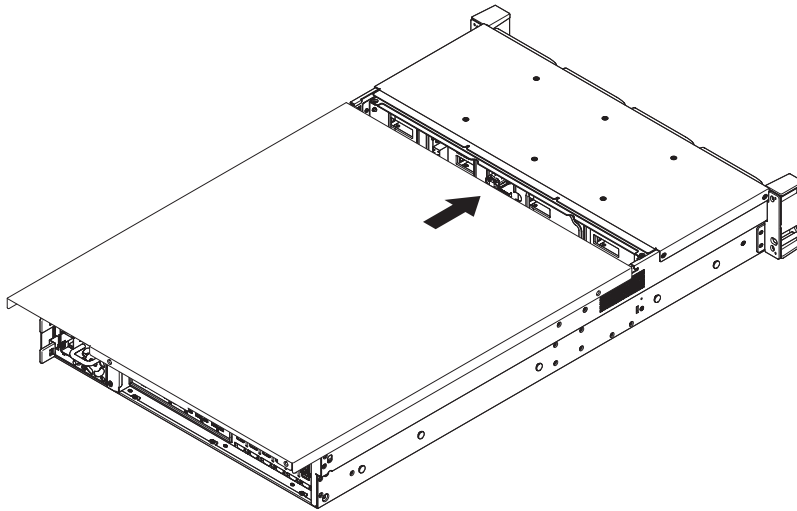

8 Secure the cover using the screws that had been removed at step 2.

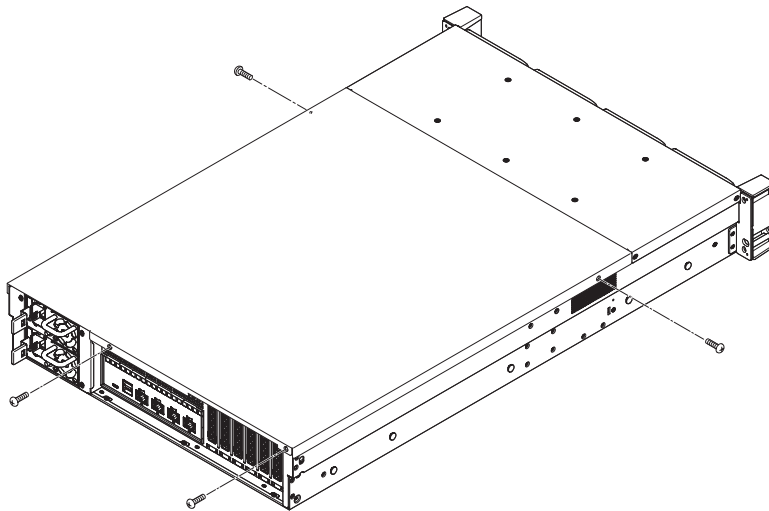

9 Connect the power cables and turn the TeraStation on.

10 The process is complete when “SSD for caching” is displayed on the drive list in Settings under *Storage > Drives* if adding an SSD card.

If adding a network card, instead check Settings to ensure the extra network port is available.

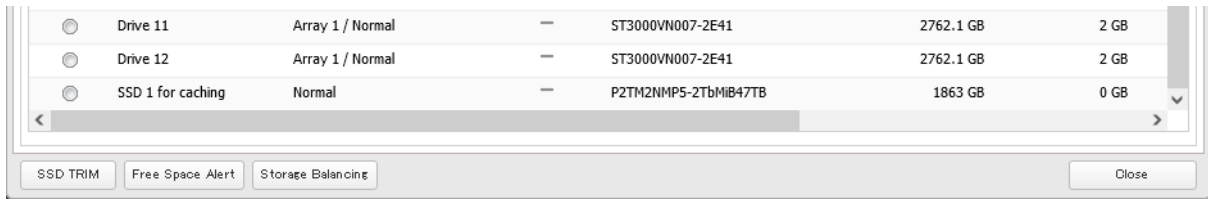

Removing an Expansion Card

Follow the procedure below to remove or replace an installed expansion card from the TeraStation.

Note: Before removing the SSD card, make sure there are no SSD caches. To delete any SSD caches, refer to the [“Deleting an SSD Cache”](#) section in chapter 5.

- 1** Power off the TeraStation and unplug the power cables from the unit.
- 2** Remove the screws on the sides and back of the TeraStation.

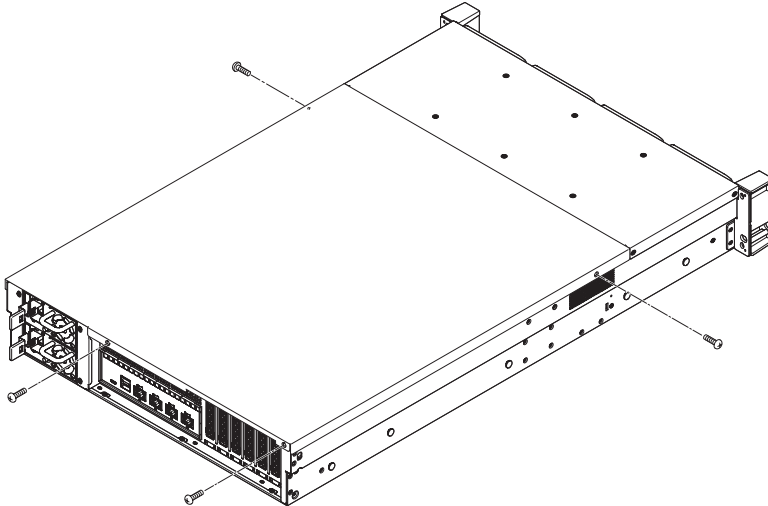

- 3** Slide the rear top cover to the back side and lift it up to remove it from the TeraStation.

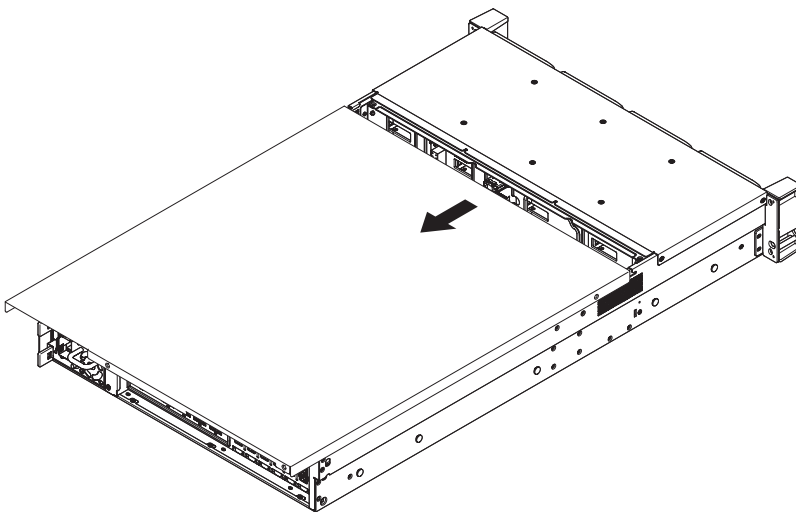

- 4** Remove the screw of the expansion card and move the card upwards to remove it from the slot.

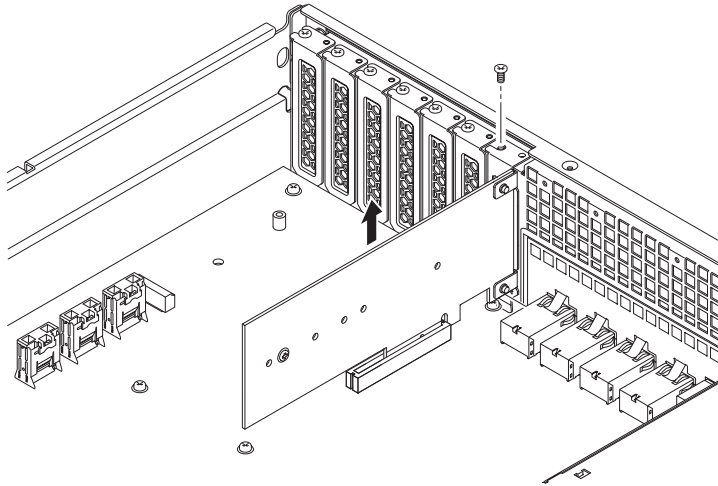

- 5** Proceed to the next step after removing the expansion card. If you want to replace the removed expansion card with another card, refer to the [“Adding an Expansion Card”](#) section above for the procedure.

- 6** Return the PCIe slot cover you kept and secure the cover using the screw to prevent dust from entering into the TeraStation.

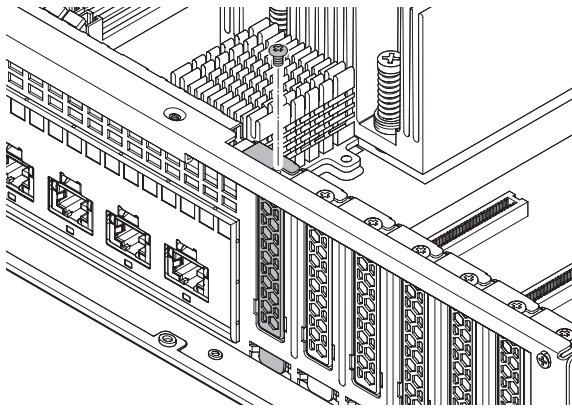

- 7** Return the rear top cover back and slide it into the secure position.

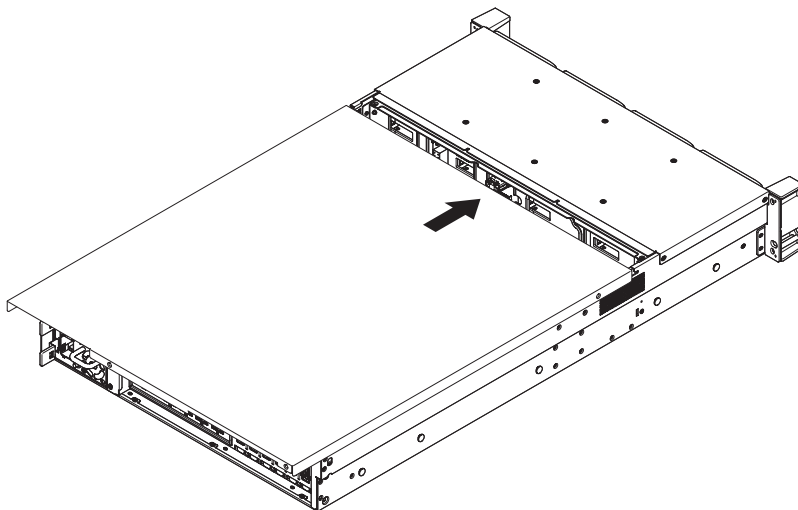

8 Secure the cover using the screws that had been removed at step 2.

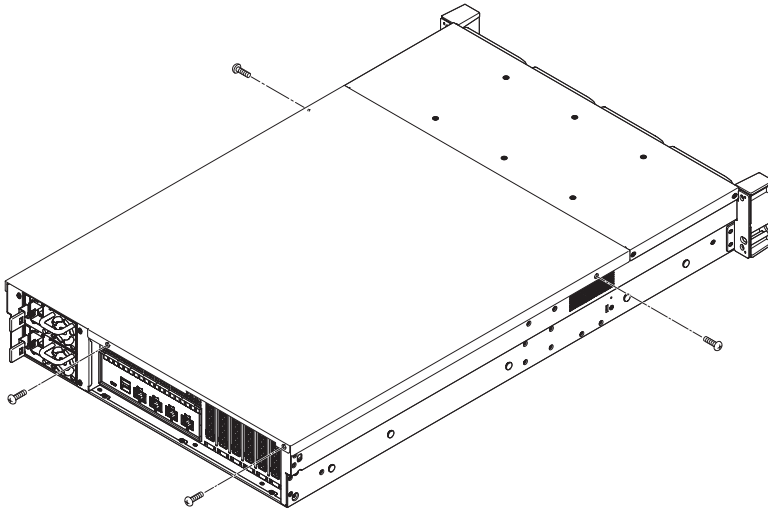

9 Connect the power cables and turn the TeraStation on.

10 The process is complete when the TeraStation is powered on.

Installing or Uninstalling Memory Modules

There are four memory slots available on the TeraStation. By adding the memory modules to these slots, you can increase the total memory capacity of the TeraStation.

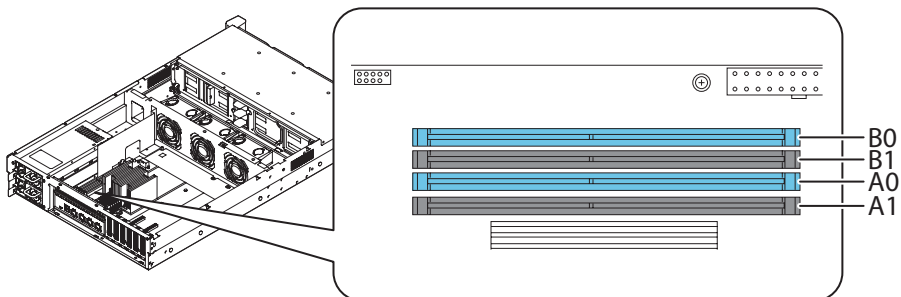

Location Pair Chart

Make sure you are using the correct slots when installing memory modules by referring to the chart of available location pairs below.

Channel B0	Channel B1	Channel A0	Channel A1	Total Capacity
16 GB	-	-	-	16 GB
16 GB	-	16 GB	-	32 GB
16 GB	16 GB	16 GB	16 GB	64 GB

Adding a Memory Module

Follow the procedure below to install a memory module.

1 Power off the TeraStation and unplug the power cables from the unit.

2 Remove the screws on the sides and back of the TeraStation.

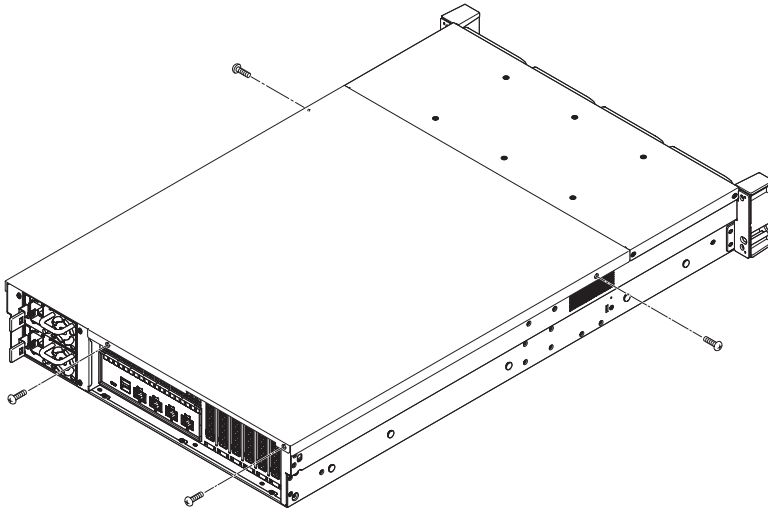

3 Slide the rear top cover to the back side and lift it up to remove it from the TeraStation.

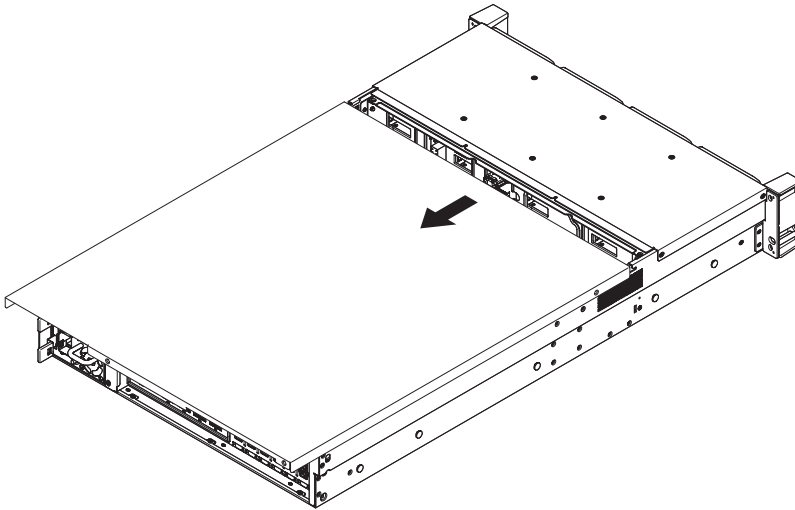

4 Insert the new memory module into an empty slot. Align the notches on the module with the ridge to the slot and firmly push the module in.

The memory module must be inserted into the appropriate location for corresponding pairs. Refer the ["Location Pair Chart"](#) above before inserting the new memory module.

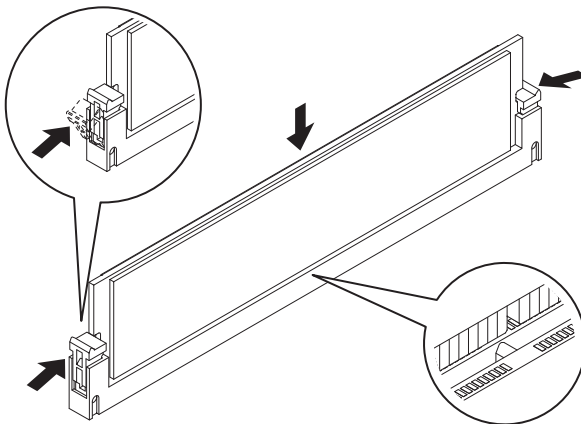

5 Return the rear top cover back and slide it into the secure position.

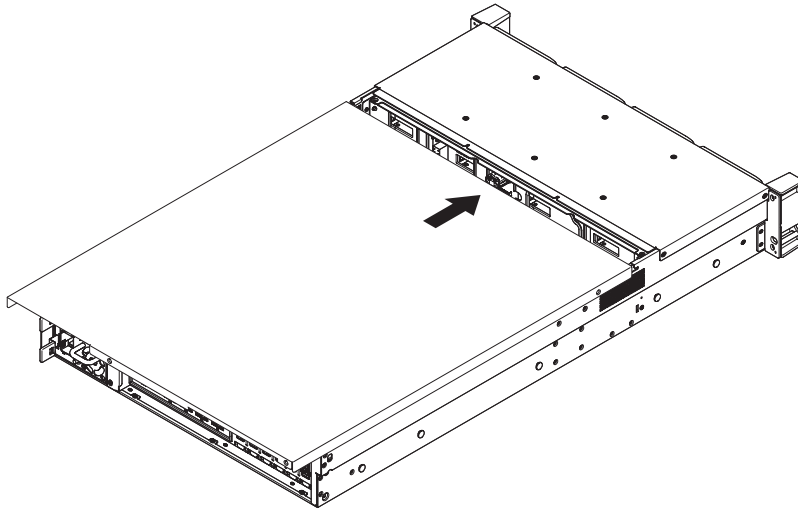

6 Secure the cover using the screws that had been removed at step 2.

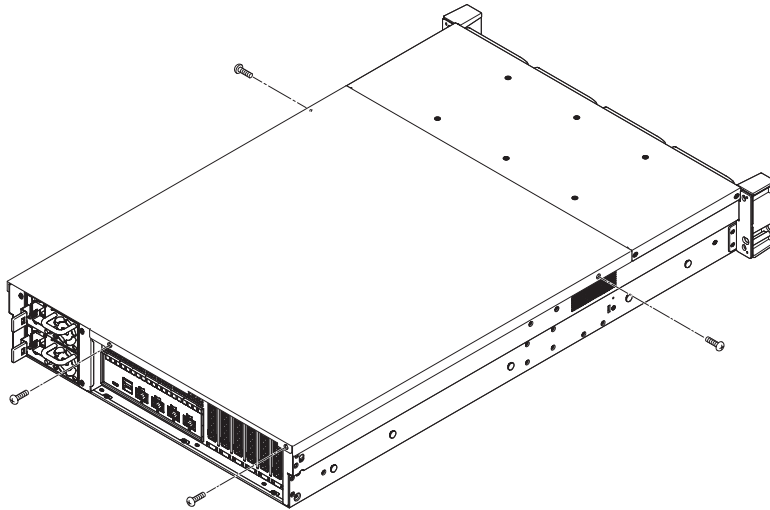

7 Connect the power cables and turn the TeraStation on.

8 The process is complete when the memory capacity is shown to have increased on the Dashboard in Settings.

Name	TS71210R100
Firmware Version	1.00-2.17
Serial Number	
Workgroup	WORKGROUP
Administrator	Not configured
Location	Not configured

Memory Usage: 7% / Memory Capacity: 32 GB ^

The graph shows a horizontal bar at the 7% mark on the y-axis, which is labeled from 0 to 100 in increments of 25. The x-axis is labeled from 60 to 0 in increments of 10, representing seconds.

Removing a Memory Module

To remove or replace an installed memory module from the TeraStation, follow the procedure below.

1 Power off the TeraStation and unplug the power cables from the unit.

2 Remove the screws on the sides and back of the TeraStation.

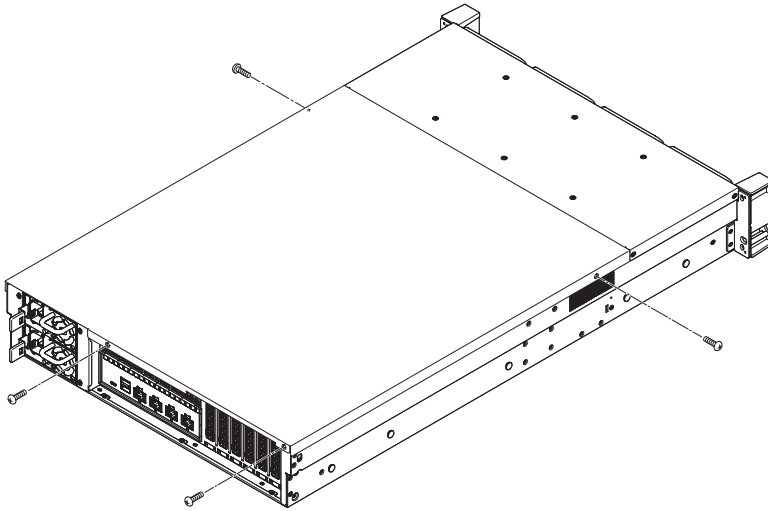

3 Slide the rear top cover to the back side and lift it up to remove it from the TeraStation.

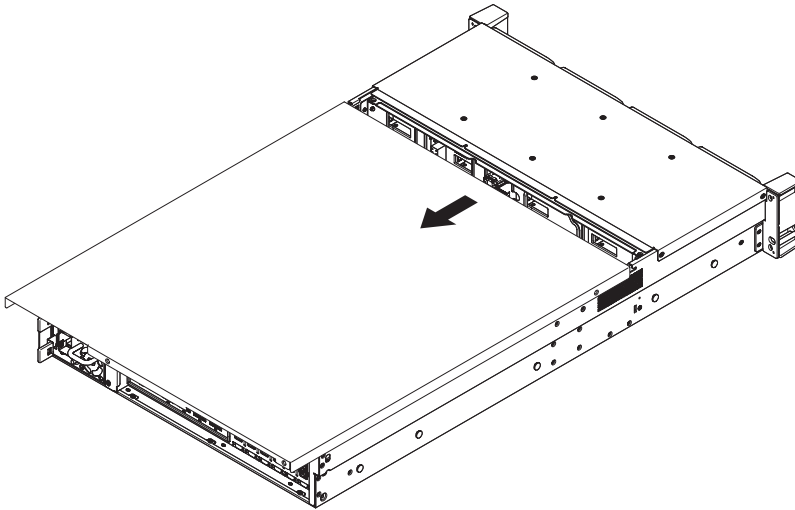

4 Press down the clips on the sides of the module and the memory module will be pushed up. Remove it from the slot.

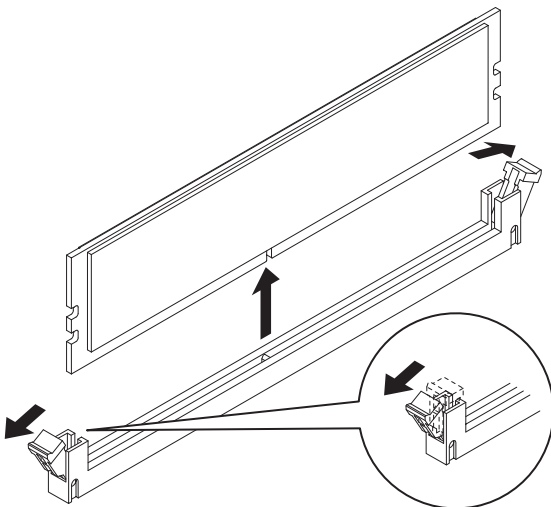

5 Proceed to the next step after removing the memory module. If you want to replace the removed memory module with another module, refer to the [“Adding a Memory Module”](#) section above for the procedure.

6 Return the rear top cover back and slide it into the secure position.

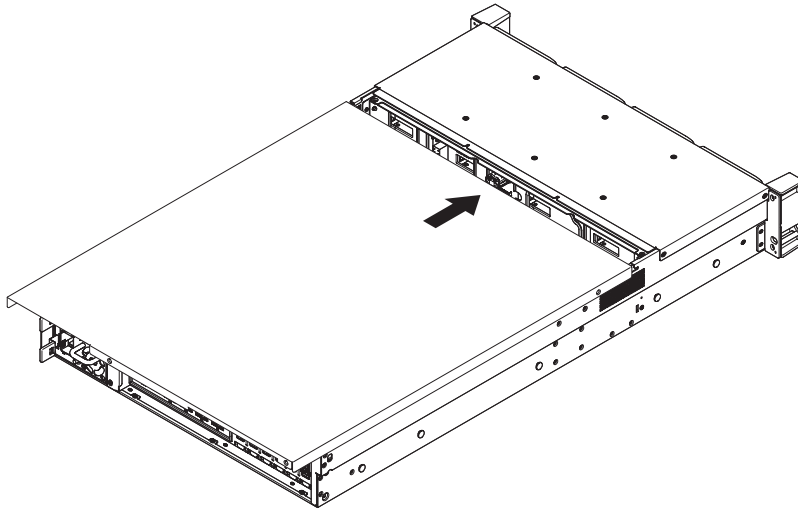

7 Secure the cover using the screws that had been removed at step 2.

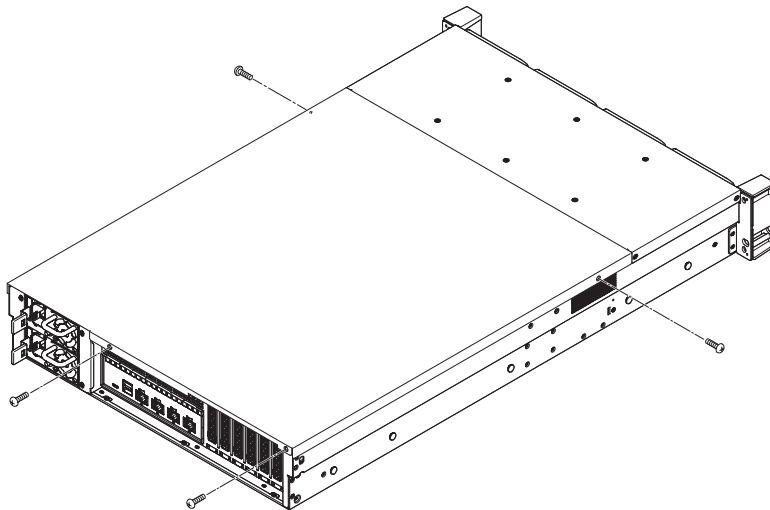

8 Connect the power cables and turn the TeraStation on.

9 The process is complete when the TeraStation is powered on.

Chapter 3 Getting Started

Turning the TeraStation On and Off

Press the power button on the TeraStation to turn it on.

To turn off the TeraStation, press and hold down the power button for three seconds. When the power LED turns off, the shutdown process is finished.

Don't unplug the power cable without powering the TeraStation off first.

Notes:

- Do not disconnect or reconnect the internal drives while turning the TeraStation on or off.
- While the power cable is connected, the fan will keep moving. To stop the fan, disconnect the power cable.
- If the power cable is disconnected after the TeraStation is turned off, the TeraStation will beep. To stop the beeping, press the beep off button. Refer to the "[Diagrams](#)" section in chapter 2 for the location of the beep off button.

You can also shut down or restart the TeraStation remotely from Settings. For the detailed procedure, refer to the "[Shutting Down or Restarting the TeraStation from Settings](#)" section below.

Creating a USB Initialization Drive

We recommend creating a USB initialization drive as soon as possible. This USB drive can be used to initialize the TeraStation's settings to its factory default values or recover the system if your TeraStation encounters an error that prevents the unit from booting. For the detailed procedure, refer to the "[Creating a USB Initialization Drive](#)" subsection in chapter 9.

Accessing Settings

Configure and manage your TeraStation using the Settings interface, accessible from a browser window. Open the interface using the appropriate procedure below or type the TeraStation's IP address into the URL field of your browser.

Note: Microsoft Edge, Firefox, Google Chrome, Internet Explorer 9 or later, and Safari 9 or later are supported. If you have difficulty viewing Settings, check the following:

- If there are a large number of registered users, groups, or shared folders, use another browser instead of Internet Explorer.
- If you have a proxy server enabled in the browser settings, configure the exception settings for Settings or disable the proxy server.
- With Internet Explorer, set security to *Local intranet*. On Windows Server operating systems, higher-level security is configured by default. Set the security to a lower level temporarily.

Opening Settings

- 1 Double-click the NAS Navigator2 icon () to start NAS Navigator2.

- 2** Right-click your TeraStation's icon and select *Open Settings*. For macOS, select the TeraStation's icon while holding down the control key, then select *Open Settings*.

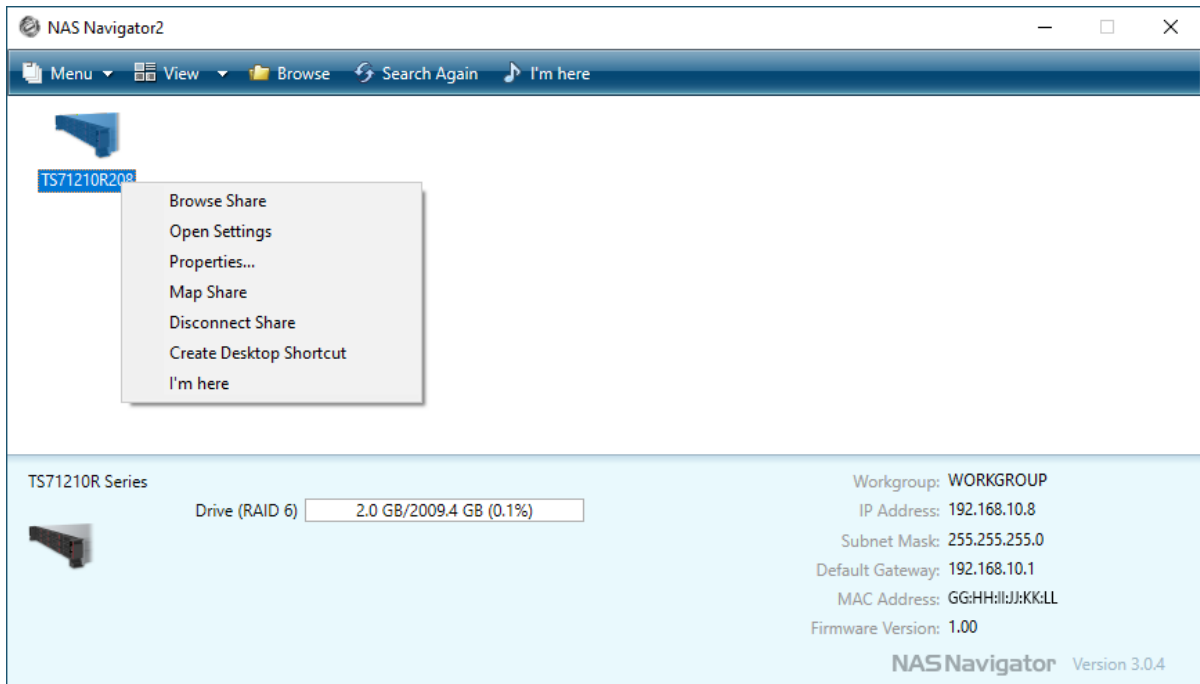

- 3** Enter the username and password, then click *OK*.

The screenshot shows the Buffalo login screen. At the top is the "BUFFALO" logo in red. Below it is a text input field containing the username "admin". Underneath is a checkbox labeled "Log in as a different user" which is unchecked. Below that is a password input field labeled "Password". At the bottom, there is a "Time-Out Period" section with two radio buttons: "10 minutes" (which is selected) and "Unlimited". A large blue "OK" button is centered at the bottom. Below the "OK" button is a link labeled "Secure Connection".

Notes:

- If the time-out period is set to "10 minutes", you will be logged out of Settings after 10 minutes of inactivity.
- Click *Secure Connection* to log in using an encrypted connection. For detailed information about encrypted connections, refer to the "[Encrypting Data Transmission](#)" section in chapter 8.

4 If you did not enable two-factor authentication, skip to step 5. Otherwise, refer to the authenticator app on your mobile device for the verification code. Enter the verification code and click *OK*.

Note: For detailed information about two-factor authentication, refer to the [“Two-Factor Authentication”](#) section in chapter 8.

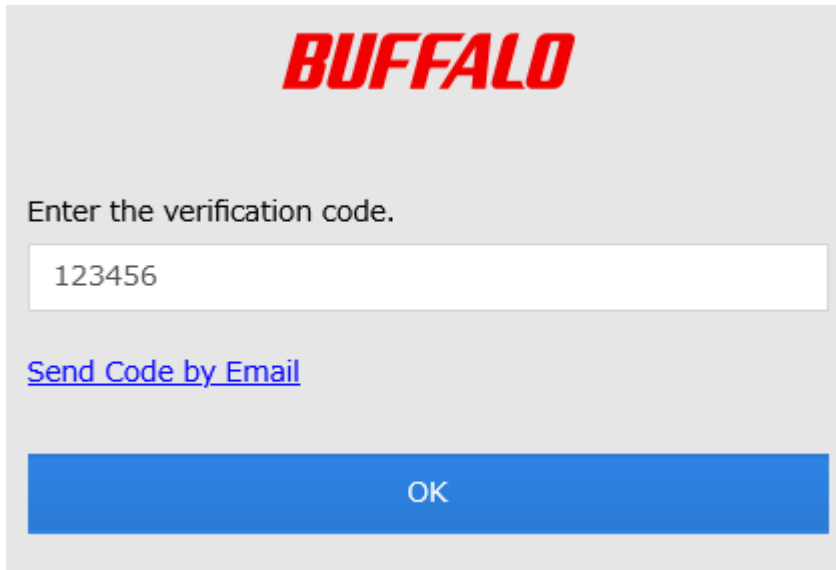

5 The process is complete when the Settings page opens.

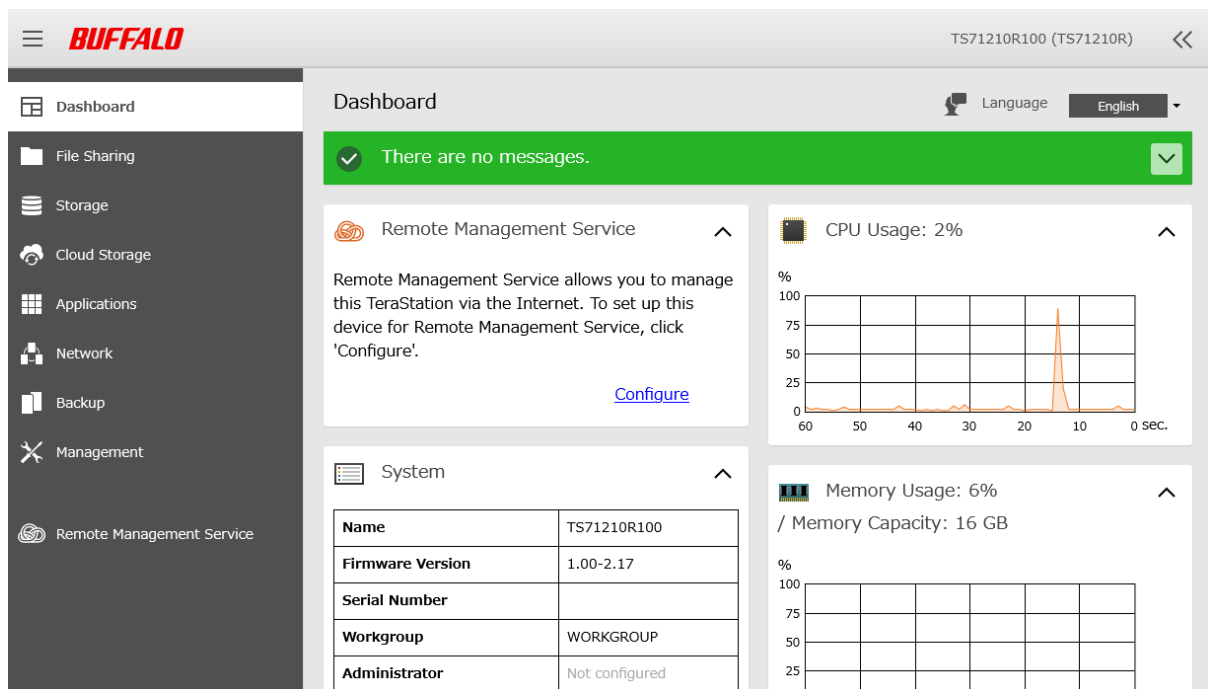

Notes:

- Username/Password Combinations:

Username	Password	Settings Available
admin (default)	password (default)	All
guest	blank	Guest user information

Username	Password	Settings Available
Your username	Your password	If a user is assigned as an administrator, all settings are available. If assigned to a power users group, creating or editing shared folders, users, and groups is available. If assigned to a general users group, only changing the password of logged-in users is available.

- Click  at the top-right of Settings and choose *I'm here* to have the TeraStation beep so it can be located easily.

Configuring Settings via Setup Wizard

When you access Settings for the first time, or after initializing the TeraStation's settings, the setup wizard will automatically appear to help you configure several TeraStation settings, such as RAID mode and proxy server settings.

An example screen of the setup wizard is displayed below. Step through the wizard to configure any desired settings. If there is any setting you would like to configure later, click *Skip* to move to the next setup wizard screen, or click *Cancel* to exit the wizard. You may run the setup wizard at a later time after initial setup, or after system initialization.

Example of Setup Wizard Screen

Administrator Password

Change the administrator password.
For security reasons, please enter a new admin password below.

Show entered password

Password: 

Enter the password again to confirm.

Password (Confirm):

To launch the setup wizard at a later time, follow the procedure below.

- 1 From Settings, click *Management*.

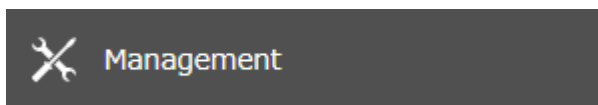

- 2 Click the settings icon () to the right of "Restore/Erase".



3 Click *Execute Wizard*.



4 The “Confirm Operation” screen will open. Enter the confirmation number, then click *OK*.

5 Follow the procedure on the screen and finish the setup wizard.

6 The process is complete once you close the wizard.

Checking the Device Information from Dashboard

When opening the Settings interface, the Dashboard page will appear first. Dashboard will show the following device information:

- Notices, such as information events and errors
- System information, such as hostname, firmware version, IP address, etc.
- Drive information, such as used space of internal drives, LVM volumes, iSCSI volumes, etc.
- CPU, system memory usage, and memory capacity
- Network information*, such as IP address, link speed, sent and received rates, etc.

*If accessing via iSER connections, packets sent and received will not be displayed.

Notes:

- As the number of files on the TeraStation increases, memory usage will also rise. This usage will gradually decrease over time. To reduce memory usage immediately, try the following operations:
 - Restarting the TeraStation.
 - Dismounting the USB drive.

- If there is not enough free space on the TeraStation, it may cause abnormal system behavior. Make sure that there is always at least 1 GB or more of free space on the TeraStation.
- You can click the *Clear* button to delete any messages from the Dashboard.

Shutting Down or Restarting the TeraStation from Settings

You can shut down or restart the TeraStation remotely. Follow the procedure below to remotely shut down or restart the TeraStation from Settings.

- 1** Log in to Settings using NAS Navigator2.
- 2** Click  at the top-right of Settings and choose *Shut Down* or *Restart*.

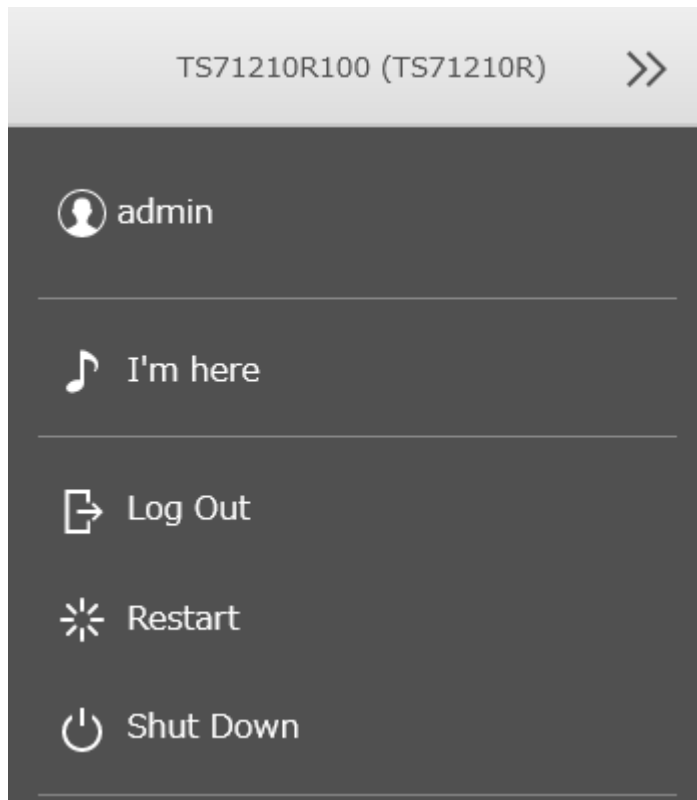

- 3** Click *Yes*.
- 4** The “Confirm Operation” screen will open. Enter the confirmation number, then click *OK*.
- 5** The process is complete when the power LED is extinguished if you shut down, or turns from blinking to glowing if you restart.

Chapter 4 File Sharing

You can create users and groups to access the shared folders on the TeraStation and configure access restrictions to limit access to key data.

Configuring Shared Folders

Adding a Shared Folder

1 From Settings, click *File Sharing*.

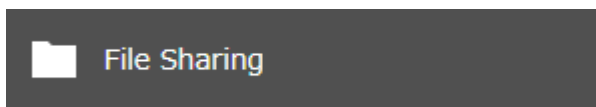

2 Click the settings icon (⚙️) to the right of "Folder Setup".



3 Click *Create*.

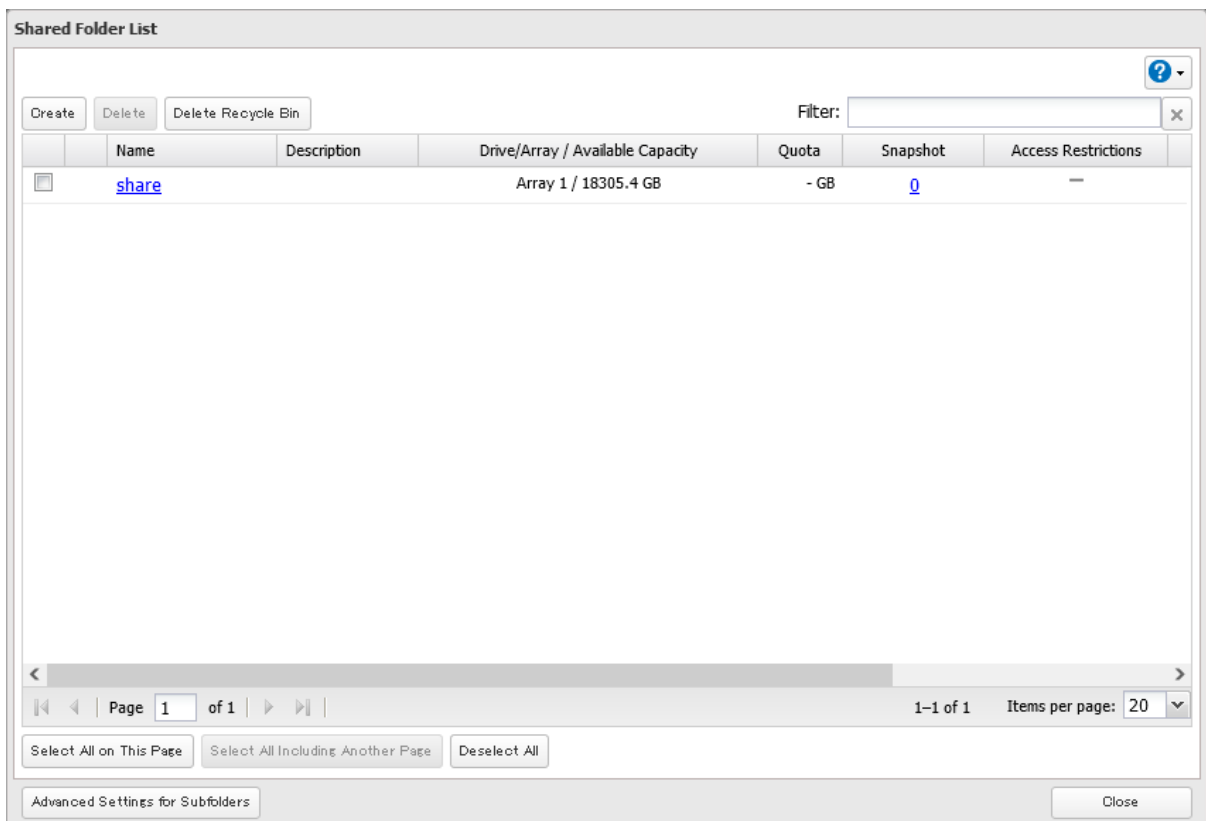

4 Configure the desired settings, then click *OK*.

Shared Folder Settings *Required ?

Basic | Option 1 | Option 2 | Access Restrictions

Copy Settings from:

Name * :

Drive/Array:

Recycle Bin: Enable Disable

LAN Protocol Support: SMB (Windows/Mac) AFP (Mac)

FTP Backup

SFTP WebAccess

NFS

— NFS Path _____

OK Cancel

5 The process is complete once you close the confirmation window that appears.

Notes:

- Names may contain up to 27 alphanumeric characters, hyphens (-), and underscores (_). Multibyte characters are supported. The first character should not be a symbol.
- When you click the *Option 1* tab, you can enter the folder description. Descriptions may contain up to 75 alphanumeric characters, hyphens (-), underscores (_), and spaces. Multibyte characters are supported. The first character should not be a space.
- You may create up to 400 shared folders.
- If the names of shared folders accessed via AFP and FTP connections contain multibyte characters, configure the client language in *Management > Name/Time/Language* to match the characters. If the setting and display language do not match, the shared folder name will not be displayed correctly.
- The following characters are handled differently by macOS and Windows devices. Avoid using these characters when sharing data between macOS and Windows devices:
— ~ // - ¢ £ ¬
- Windows does not support some characters that macOS and the TeraStation allow. If you create a filename on a macOS device that includes any of the following symbols, it will not display correctly on a Windows computer. You may have to connect to the TeraStation via AFP in order to display or copy files that contain these symbols in their filenames.
?][/\= + > < ; : " , | *
- Do not use a name that is already an existing iSCSI volume name; do not use any of the following words as a shared folder name as these words are reserved for internal use by the TeraStation: authtest, global, homes,

- 1 From Settings, navigate to *File Sharing* > *Folder Setup* and choose a shared folder.
- 2 Click the *Option 2* tab and change the “Attribute” option to “Read only”, then click *OK*.
- 3 The process is complete once you close the confirmation window that appears.

Both read-only shares and HFS Plus-formatted USB drives will have “(Read Only)” added under “Comments” in File Explorer.

Notes:

- Configure the share attribute only through Settings. Configuring folder attributes through Windows is not supported and may cause unexpected behavior.
- To set a read-only share or USB drive to another attribute, follow the procedure above and change the attribute in step 2 from “Read only” to the desired attribute.

Hidden Shares

If a shared folder becomes hidden, it will not be displayed under Network, and only certain users will be allowed to access it. To hide a shared SMB folder, follow the procedure below.

- 1 From Settings, navigate to *File Sharing* > *Folder Setup* and choose a shared folder to make hidden.
- 2 Click the *Option 2* tab and select the “Hidden share (SMB only)” checkbox, then click *OK*.
- 3 The process is complete once you close the confirmation window that appears.

Notes:

- If protocols other than “SMB (Windows/Mac)” or “Backup” under “LAN Protocol Support” on the *Basic* tab are enabled, the hidden shares option will be grayed out and cannot be selected.
- Configure hidden share attributes only through Settings. Configuring them through Windows is not supported and may cause unexpected behavior.

To access a hidden folder, open File Explorer in your computer and enter “\\TeraStation name\shared folder name\$” into the address bar. For example, if the TeraStation name is “TSXXX001” and the shared folder name is “share”, enter “\\TSXXX001\share\$” to open it.

Configuring Users

Adding a User

Note: You may add up to 300 users, which include the default users “admin” and “guest”.

- 1 From Settings, click *File Sharing*.

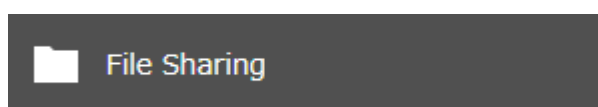

- 2 Click the settings icon (⚙️) to the right of “Users”.



3 Click Create.

The screenshot shows a 'User List' window with a tabbed interface. The 'Local Users' tab is active, and the 'Domain Users' tab is also visible. The window contains a table of users and a control panel at the bottom.

Username	Description	Group	Access Restrictions for Shared Folders
admin	Default admin user	1 ▶	<input type="button" value="Edit"/>
guest	Default guest user	1 ▶	<input type="button" value="Edit"/>

At the bottom of the window, there is a navigation bar with the following elements:

- Navigation icons: Home, Previous, Page 1 of 1, Next, End.
- Page information: Page 1 of 1.
- Items per page: 1-2 of 2, Items per page: 20 (dropdown).
- Buttons: Select All on This Page, Select All Including Another Page, Deselect All.
- Close button: Close.

4 Enter the desired settings, then click *OK*.

User Settings

*Required ?

Username * :

User ID:
Enter a number between 1000 and 1999.

Email Address:

Password * :

Password (Confirm) * :

Description:

Filter:

Group
<input checked="" type="checkbox"/> hdusers
<input type="checkbox"/> admin
<input type="checkbox"/> powerusers

Select All Deselect All

Primary Group:

OK Cancel

5 The process is complete once you close the confirmation window that appears.

Notes:

- Usernames may contain up to 128 alphanumeric characters, hyphens (-), underscores (_), periods (.), and the symbols ! # & @ \$ * ^ %. The first character should not be a symbol.
- The user ID should be a number from 1000 to 1999. Each user ID should be unique. If this field is left blank, a user ID is assigned automatically.
- Do not duplicate user IDs, group IDs, usernames, or group names. Each should be distinct and unique.
- User descriptions may contain up to 75 alphanumeric characters, hyphens (-), underscores (_), and spaces. Multibyte characters are supported. The first character should not be a symbol or space.
- Passwords may contain up to 20 alphanumeric characters, hyphens (-), underscores (_), spaces, commas (,), periods (.), semicolons (;), tildes (~), and the symbols ! # & @ \$ * ^ % + = ?] [} { \. The first character should not be a symbol unless it is an underscore.
- Use the same username and password for both Windows and the TeraStation or you may be unable to access shared folders.
- Do not use a name that is already an existing group name; do not use any of the following words as a username as these words are reserved for internal use by the TeraStation: _lldpd, adm, admin, administrator, admins, all, apache, audio, avahi, avahi-autoipd, backup, bin, cdrom, crontab, daemon, dialout, dip, disk, fax, floppy, ftp, ftpuser, fuse, games, gnats, guest, guests, halt, hdusers, irc, kmem, libuuid, list, lp, mail, man, messagebus, mysql, netdev, news, nobody, nogroup, none, ntp, openldap, operator, plugdev, powerusers, proftpd, proxy, puppet,

root, rpc, rpcuser, sambashare, sasl, shadow, shutdown, snmp, splx, src, ssh, sshd, staff, statd, sudo, sync, sys, syslog, tape, tmhttpd, tty, users, utmp, uucp, video, voice, winbindd_priv, www, www-data

- When creating a new user with admin or power user privileges, make sure to add the default groups “admin” for users with admin privileges or “powerusers” for those with power user privileges, in addition to any other manually-added groups.

Importing User Information

You can import users in *File Sharing > Users* by clicking *Import CSV File*.

An example format for user data: Username (required), password (required), and user description (optional).

Example 1: Importing usernames, passwords, and comments

```
username1,password1,comment1
username2,password2,comment2
username3,password3,comment3
```

Example 2: Importing usernames and passwords

```
username1,password1,
username2,password2,
username3,password3,
```

Guidelines:

- Use commas (,) as separators. Do not put spaces before or after commas. If you don’t want user descriptions, use a comma after the password at the end.
- If a line is in an incorrect format, the username entered on that line will not be registered.
- If an unavailable name is used by a user or if the username already exists, an error will occur and cancel the import process. User whose usernames were entered during or after the error occurs will not be imported.
- Do not use commas (,) in the username, password, or user description.

Note: Imported users are added to the “hdusers” group automatically.

Adding a Group

Note: You may add up to 300 groups.

- 1 From Settings, click *File Sharing*.

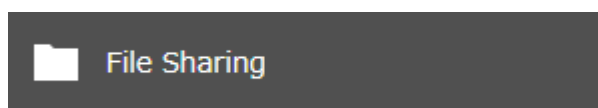

- 2 Click the settings icon () to the right of “Groups”.



3 Click Create.

The screenshot shows the 'Group List' window with the 'Local Groups' tab selected. It features a table of groups and a bottom navigation bar.

Group Name	Description	Users	Access Restrictions for Shared Folders
hdusers	Default general group	0	<input type="button" value="Edit"/>
admin	Default admin group	1	<input type="button" value="Edit"/>
guest	Default guest group	1	<input type="button" value="Edit"/>
powerusers	Default power users...	0	<input type="button" value="Edit"/>

Page 1 of 1 | 1-4 of 4 | Items per page: 20

Select All on This Page | Select All Including Another Page | Deselect All

Close

4 Enter the desired settings, then click *OK*.

5 The process is complete once you close the confirmation window that appears.

Notes:

- Group names may contain up to 20 alphanumeric characters, hyphens (-), underscores (_), and periods (.). The first character should not be a symbol.
- Group descriptions may contain up to 75 alphanumeric characters, hyphens (-), underscores (_), and spaces. Multibyte characters are supported. The first character should not be a symbol or space.
- If the group ID field is left blank, a group ID is automatically assigned. Use numbers between 1000 and 1999 to set a group ID manually. Don't use duplicate group IDs.
- If you are logged in as an administrator, you can change any setting, including other users' passwords. If you are logged in as a member of the power users group, you can create and edit shared folders, users, and groups. If you are logged in as a member of the general users group, you can only change your own password.
- Do not use a name that is already an existing username; do not use any of the following words as a group name as these words are reserved for internal use by the TeraStation: _lldpd, adm, admin, administrator, admins, all, apache, audio, avahi, avahi-autoipd, backup, bin, cdrom, crontab, daemon, dialout, dip, disk, fax, floppy, ftp, ftpuser, fuse, games, gnats, guest, guests, halt, hdusers, irc, kmem, libuuid, list, lp, mail, man, messagebus, mysql, netdev, news, nobody, nogroup, none, ntp, openldap, operator, plugdev, powerusers, proftpd, proxy, puppet, root, rpc, rpcuser, sambashare, sasl, shadow, shutdown, snmp, splx, src, ssh, sshd, staff, statd, sudo, sync, sys, syslog, tape, tmhttpd, tty, users, utmp, uucp, video, voice, winbindd_priv, www, www-data

Configuring Access Restrictions

You may restrict access for specific shared folders, including external USB drives.

Notes:

- Configure access restrictions only through Settings. Configuring access restrictions through Windows is not supported and may cause unexpected behavior.
- Shared folders with limited access can still be used as backup destinations.
- If you grant both read-only and read and write access to the users or groups, the attributes will become as below:

User permissions	Group permissions		
	Group with read and write access	Group with read-only access	Group with no access
User with read and write access	R/W	R	R/W
User with read-only access	R	R	R
User with no access	R/W	R	-

R/W: Read and write, R: Read-only, -: No access

- If you change access restrictions for a user or group while they are accessing files, unexpected behavior may occur.

Restricting Local User Access to Shared Folders

- 1 From Settings, click *File Sharing*.

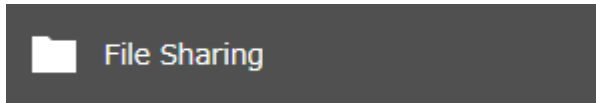

- 2 Click the settings icon () to the right of "Folder Setup".



3 Click the shared folder that you want to set access restrictions for.

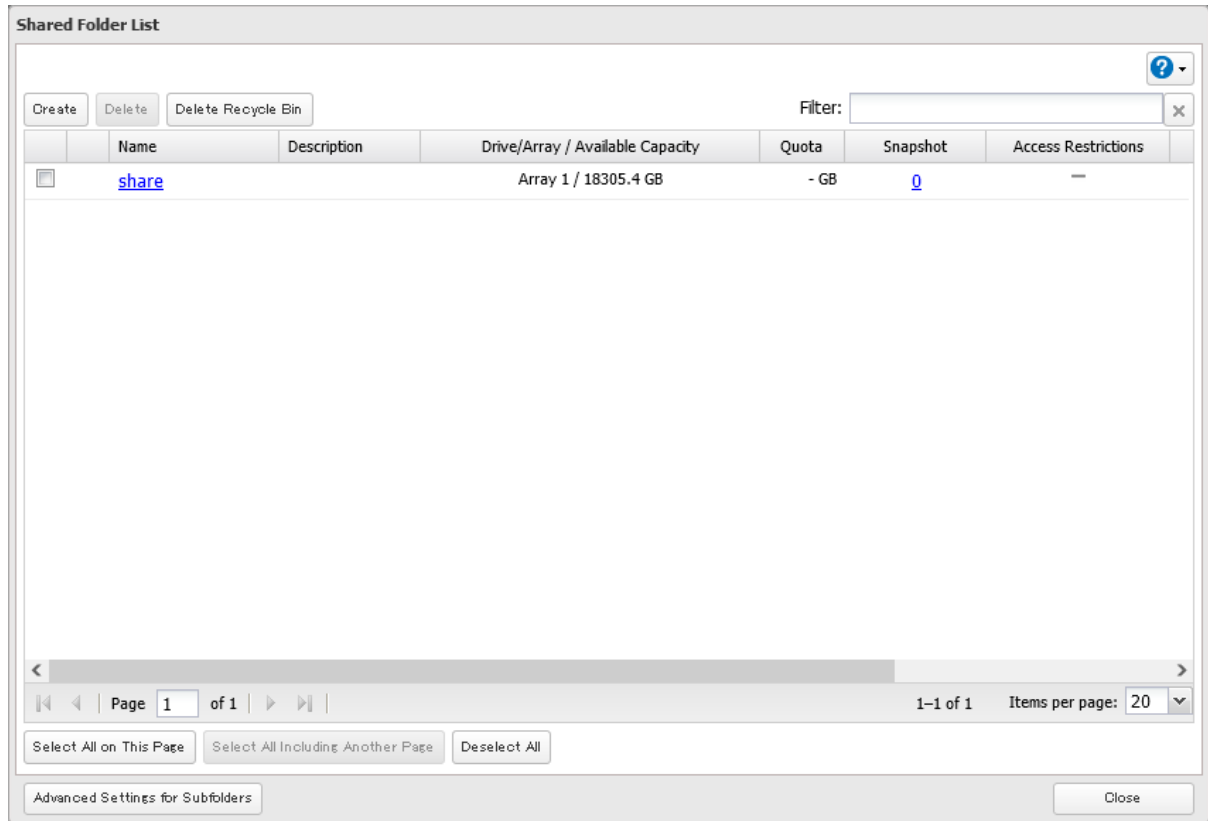

4 Click the *Access Restrictions* tab, then enable "Access Restrictions for Shared Folders".

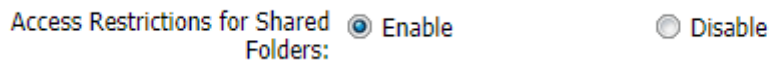

5 Select the level of access for the user or group and click *OK*.

: Read and write : Read-only : No access



Note: The example above shows access restrictions by users. To restrict access by group, click the *Local Groups* tab and select group permissions.

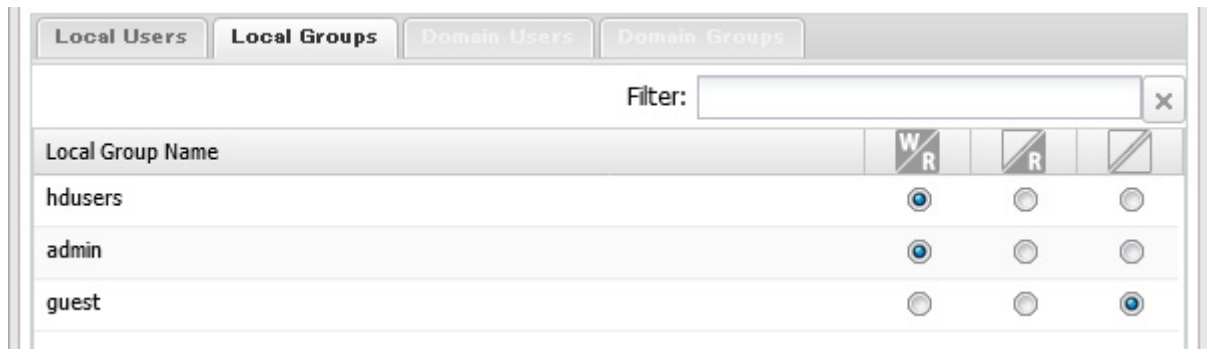

6 The process is complete once you close the confirmation window that appears.

Note: For an access-restricted shared folder, if you change the access restrictions of all users and groups from read and write or read-only to access prohibited from the user or group list page in Settings, that shared folder can only be accessed by admin users and groups.

Restricting AD Domain User Access to Shared Folders

If there is an Active Directory environment, the TeraStation will use account information from the Active Directory domain controller to set access restrictions for shared folders on the TeraStation. There is no need to perform individual account management for the TeraStation. If multiple TeraStations are installed on the network, the account information will be centrally managed in Active Directory, greatly reducing the operations required for installation and management.

Notes:

- If usernames or group names from Active Directory include multibyte characters, you will not be able to configure access restrictions for them.
- The TeraStation supports an Active Directory domain environment with a maximum of 10,000 users and groups total.

1 From Settings, click *Network*.



2 Click the settings icon (⚙️) to the right of "Workgroup/Domain".



- 3** Click *Edit* and select “Active Directory”, then click *Next*.

Workgroup/Domain Settings

Authentication Method

Workgroup

Active Directory

Next Cancel

- 4** Enter the domain controller information and click *Search*. The domain controller on the same network will be detected and required settings will be populated into each field automatically. Alternatively, you can also enter the settings manually.

Active Directory Domain Settings

*Required ?

Detect Domain Controller : Search
(IP Address, DNS Name, or Computer Name)

NetBIOS Name * :

DNS Name * :

Domain Controller Name * :
(Computer Name)

Administrator Name * :

Administrator Password * :

WINS Server IP Address:

Configure domain controller as an NTP server

OK Cancel

- 5** If there is a difference of more than five minutes between the TeraStation’s clock and the domain controller’s clock, joining the domain or authenticating domain users and groups may fail. For best results, select “Configure domain controller as an NTP server” if the domain controller can function as the NTP server.

- 6** Click *OK*.

- 7** From Settings, click *File Sharing*.

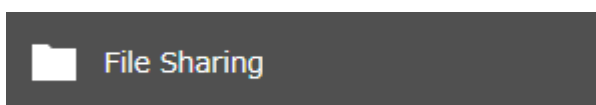

8 Click the settings icon () to the right of “Folder Setup”.



9 Click the shared folder that you want to set access restrictions for.

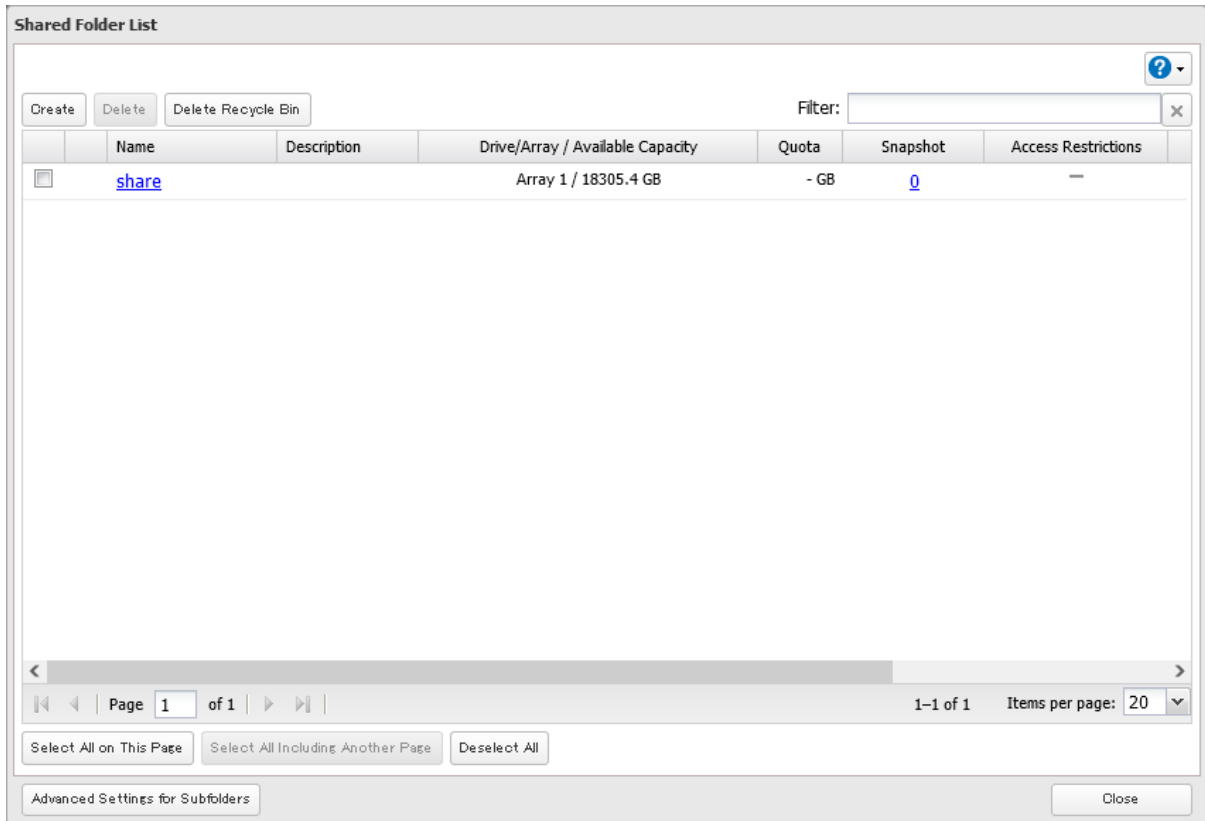

10 Click the *Access Restrictions* tab, then enable “Access Restrictions for Shared Folders”.

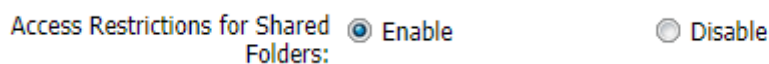

11 Select the level of access for the user or group and click *OK*.



12 The process is complete once you close the confirmation window that appears.

Notes:

- To have the TeraStation join an Active Directory domain, configure it to use a DNS server that can resolve names for the Active Directory domain.
- After building an Active Directory domain, the administrator password for joining the domain must be changed at least once, or joining the Active Directory domain will fail.
- The DNS name and NetBIOS name of Active Directory domains should be identical.
- If the TeraStation is a member server of an Active Directory domain, you cannot connect as a guest user via AFP.
- If your TeraStation is a member server in an Active Directory domain and you change the authentication method to “Workgroup”, the account on the domain controller will not be deleted automatically.
- If FTP is enabled, local and domain group access restrictions from the AD network will not work. Use user access restrictions instead.

- For an access-restricted shared folder, if you change the access restrictions of all users and groups from read and write or read-only to access prohibited from the user or group list page in Settings, that shared folder can only be accessed by admin users and groups.
- If you allow read and write or read-only access for most users, group access restrictions are recommended.
- Depending on the domain controller's policy settings, the domain controller may force the TeraStation to leave the Active Directory domain. If this occurs, the TeraStation will lose the domain users and groups so if you have configured access restrictions using domain accounts, these users will no longer be able to access shared folders. In such a case, change the policy settings on the domain controller or let the TeraStation join the Active Directory domain again.
- If there is a local user with the same name as a domain user, access restrictions may not work properly.
- If the TeraStation cannot establish contact with an AD domain controller, the TeraStation's performance may become slow.

Restricting Access to Subfolders

You may restrict access to subfolders in shared folders by configuring access permissions from your computer using Windows File Explorer.

Notes:

- Depending on the environment, the function may not work properly when enabled. We recommend verifying the functionality before using.
- Access permissions configuring from File Explorer is available for up to 18 files and 24 folders. This number of available access permissions may vary if access permissions are inherited from the parent object.

There is a limited number of available access permissions, so using group access permissions is recommended if the permission level is the same for multiple users; this will preserve the number of available access permissions.

1 From Settings, click *File Sharing*.

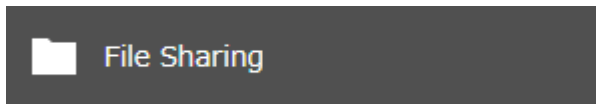

2 Click the settings icon () to the right of "Folder Setup".



3 Click the shared folder that you want to set access restrictions for.

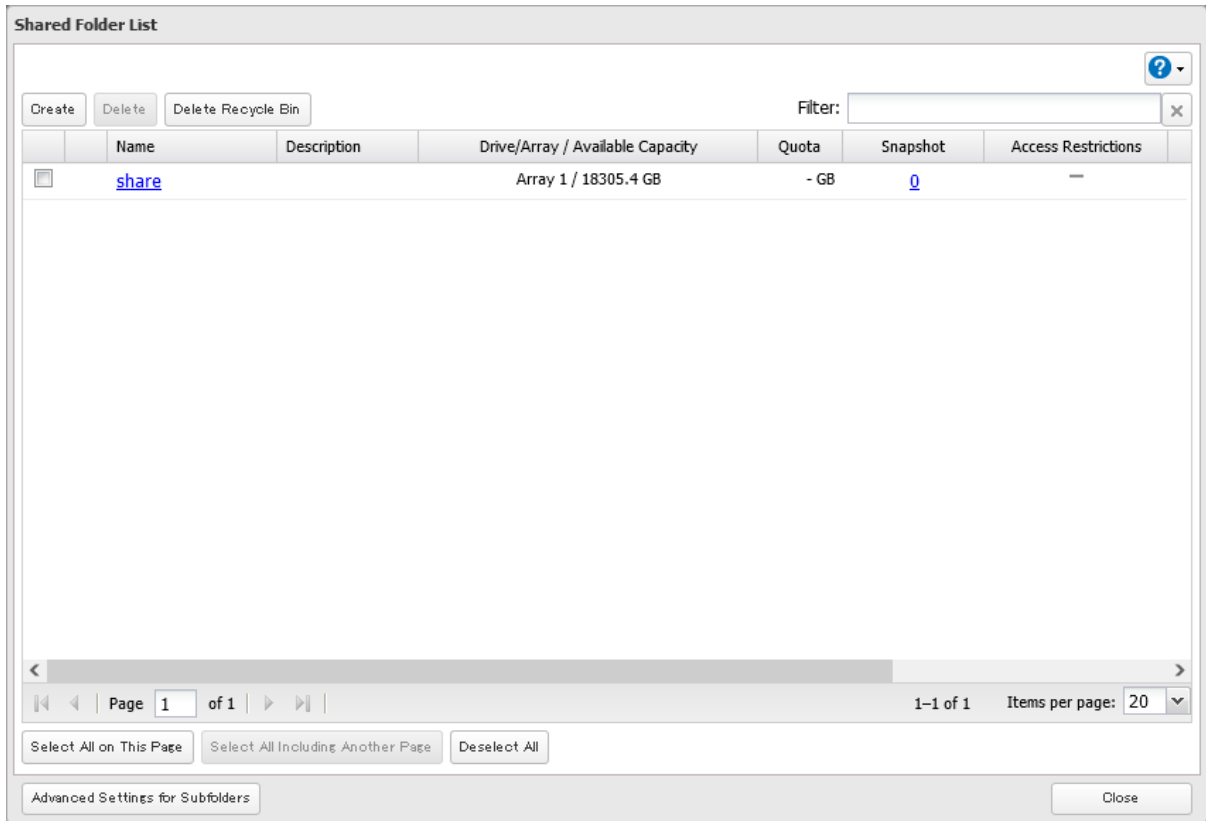

4 If any or all of the “AFP”, “FTP”, and “SFTP” checkboxes for “LAN Protocol Support” are selected, clear them all.

5 Click the *Option 2* tab and enable “Access Restrictions for Subfolders”, then click *OK*.

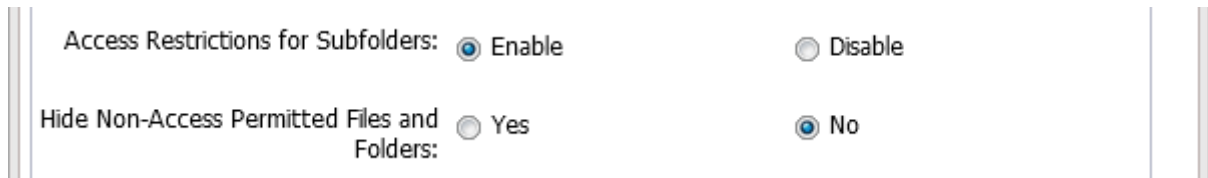

Note: If “Hide Non-Access Permitted Files and Folders” is enabled, non-access permitted sub-files and folders will not be displayed in shared folders.

6 The process is complete once you close the confirmation window that appears.

Enabling subfolders’ access restrictions finished. Next, configure access permissions for each user or group to files and folders in subfolders from File Explorer.

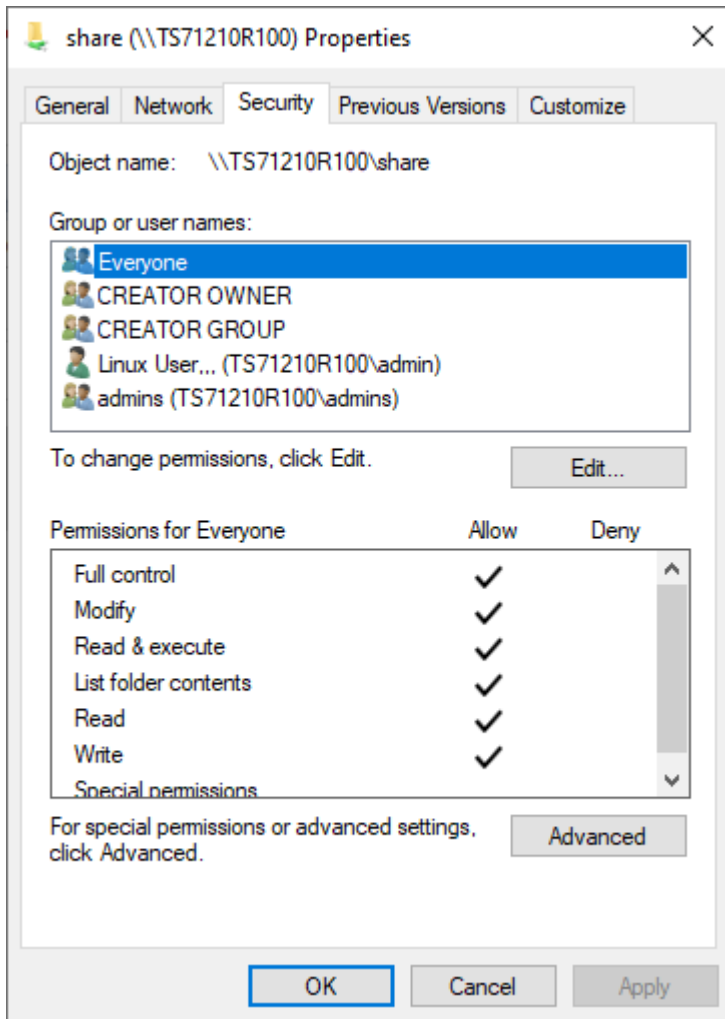

You may also configure access permissions for domain users and groups. You should have the TeraStation join your Active Directory domain before configuring access permissions from File Explorer.

Notes:

- If enabling subfolders' access restrictions for a USB drive, the drive should be formatted using Btrfs, XFS, or ext3.
- To back up or replicate files to backup or replication destinations while leaving access permissions of files and folders in subfolders unchanged, make sure the same workgroup name, user IDs, and group IDs are configured between backup or replication sources and destinations.
- If you enable subfolders' access restrictions and then clear the "Read & execute" checkbox under "Allow" on File Explorer for users or groups access permissions, these users or groups cannot be allowed to read and execute even if subfolders' access restrictions are disabled in Settings. If you deny reading and executing on the same window, this will remain after disabling subfolders' access restrictions.
- If the TeraStation's settings have been initialized but you configure the same UID and GID for new users and groups, access permissions to files and folders in subfolders may be inherited.

Improving File Access Speed Using SMB Multichannel

The TeraStation allows you to improve read and write speeds via SMB connections by using SMB multichannel to concurrently connect multiple Ethernet cables. This feature is disabled by default. To enable SMB multichannel, follow the procedure below.

Note: To use SMB multichannel, a computer that will be used for file access should support SMB multichannel.

- 1 Connect two or more Ethernet cables to the LAN ports on the TeraStation. Make sure these Ethernet cables are using the same subnet.

2 From Settings, click *File Sharing*.

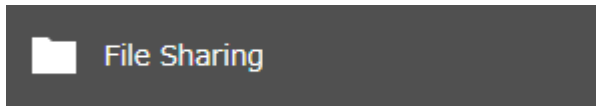

3 Click the settings icon () to the right of "SMB".



4 Click *Edit* and make sure the "Network Credentials" option has been set to "Show network credentials window".



5 Enable "Multiple Network Connections", then click *OK*.

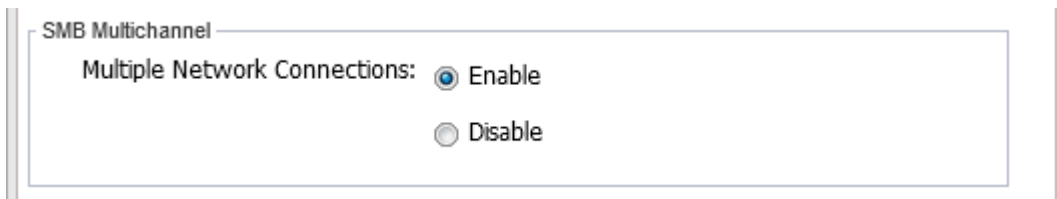

6 The process is complete when the file sharing menu list is displayed.

Enhancing Compatibility for macOS Client Access

To access shared folders via SMB connections from macOS devices, configure access from macOS devices to be enhanced over other clients such as Windows devices. By enabling this setting, file transfer speed from macOS devices will be increased, while the CPU usage rate of this TeraStation will decrease. However, the file transfer speed for non-macOS SMB clients will drop slightly.

1 From Settings, click *File Sharing*.

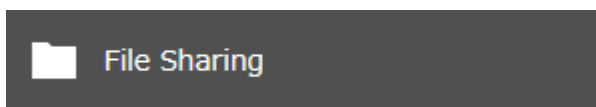

2 Click the settings icon () to the right of "SMB".



3 Click *Edit* and enable “Enhanced Compatibility with macOS Clients”, then click *OK*.



4 The process is complete when the file sharing menu list is displayed.

NFS

Note: Buffalo's customer support will help configure the NFS settings on your TeraStation, and will support VMware and Windows clients but will not provide support for configuring your Linux or other UNIX clients. There are various types of UNIX and the procedures for configuring NFS with them will vary considerably. For help configuring your NetWare, Linux, or other UNIX clients for NFS support, please consult each client's own documentation and support.

Enabling NFS

Follow the procedure below to enable NFS service to allow access from NFS clients.

1 From Settings, click *File Sharing*.

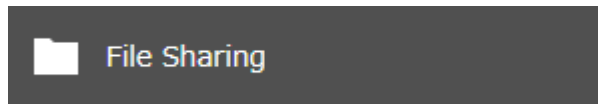

2 Click the settings icon () to the right of “Folder Setup”.



3 Choose the shared folder that will be accessible from the NFS client.

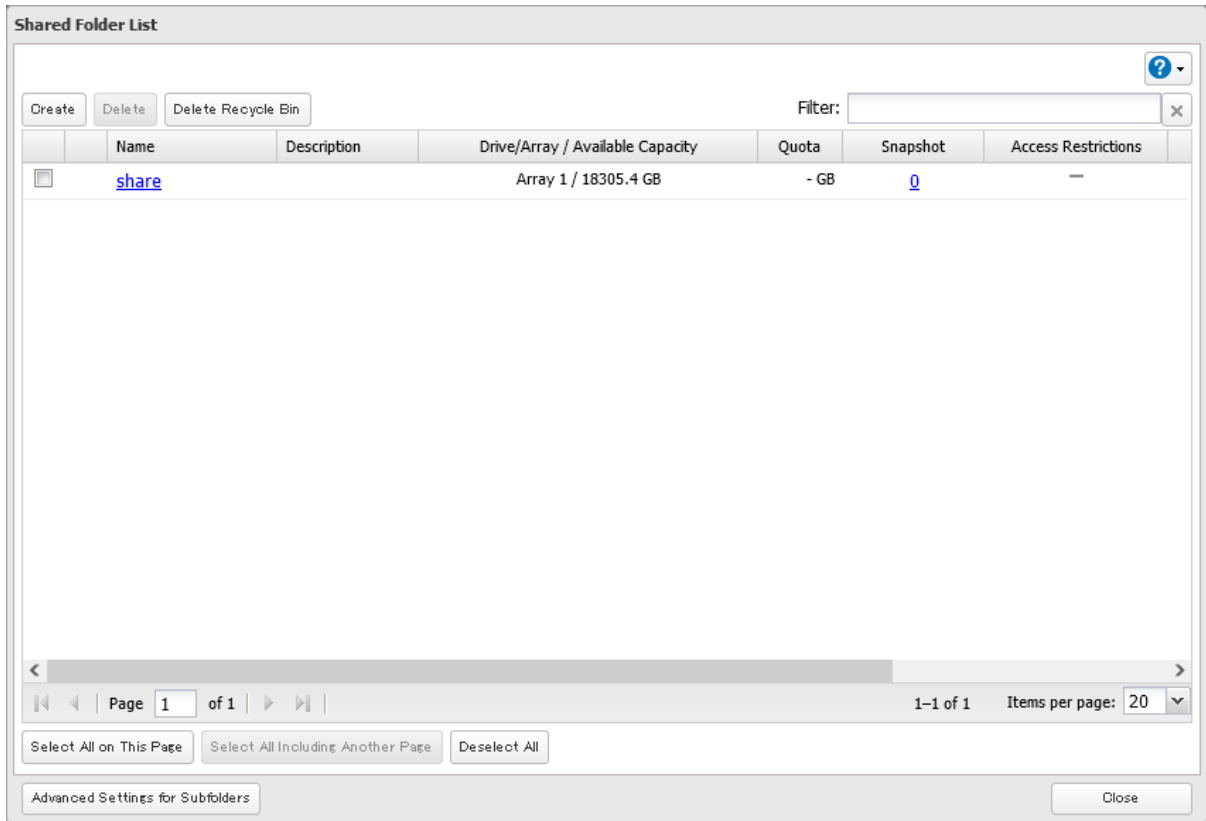

4 Under "LAN Protocol Support", select the "NFS" checkbox on the *Basic* tab and click *OK*. Note the NFS path. It will be used later for accessing data from an NFS client.

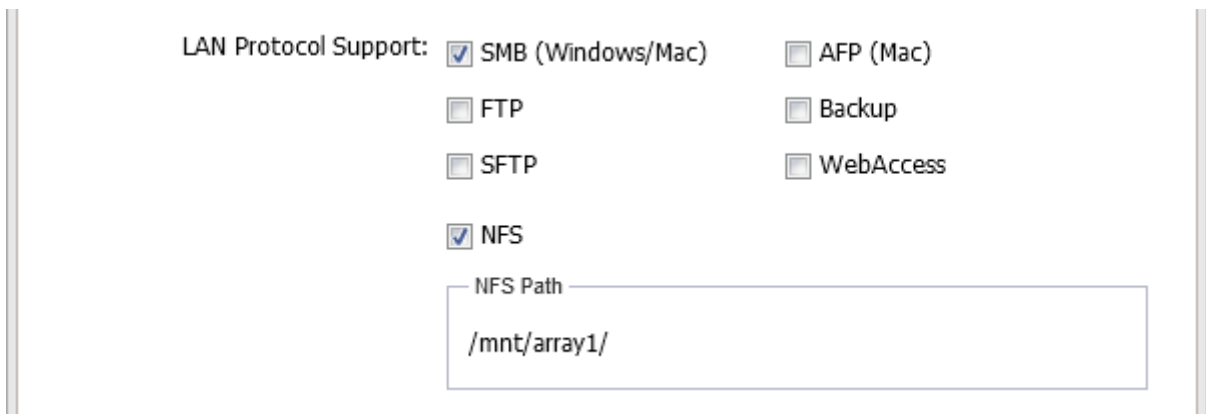

5 Click *Close*.

6 Move the NFS switch () to the  position to enable NFS.



7 Click the settings icon () to the right of "NFS".



8 Click the *Clients* tab, then click *Add*.

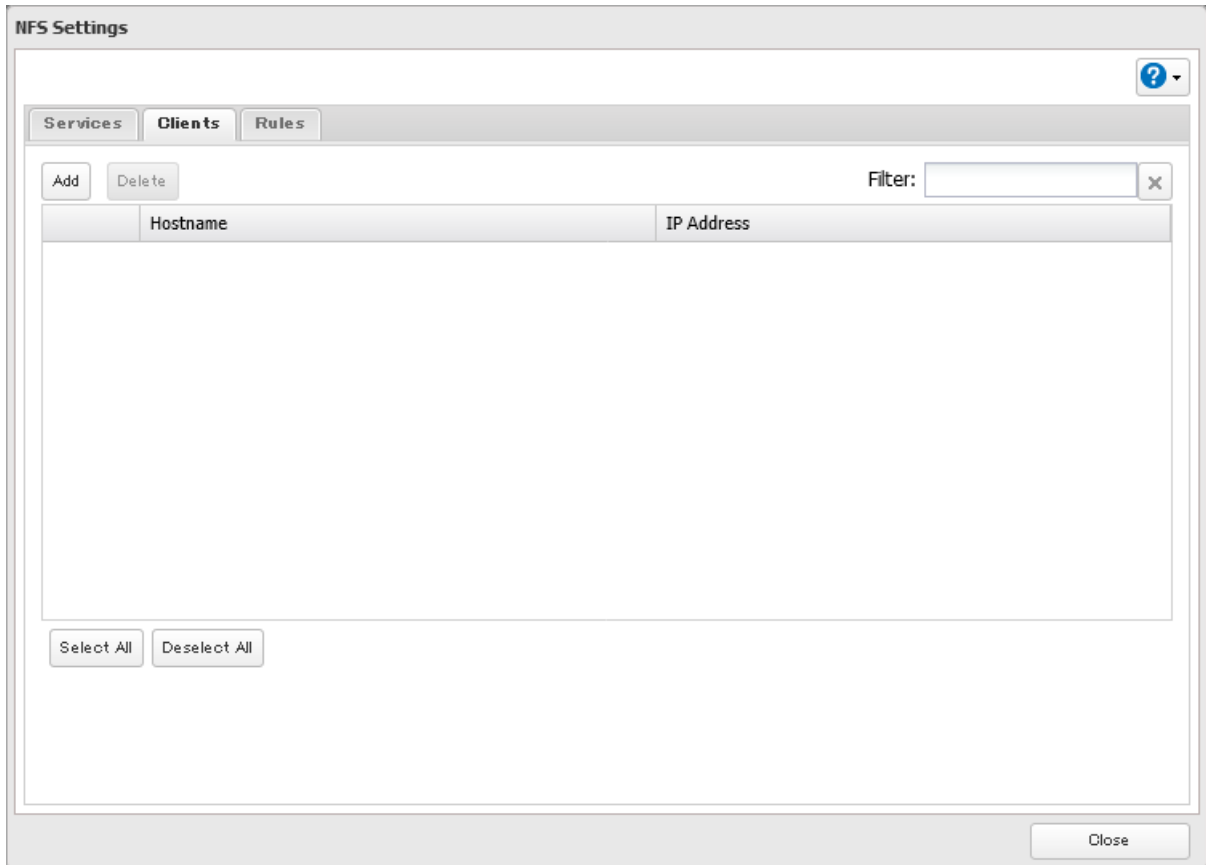

9 Enter the hostname and IP address of the NFS client, then click *OK*. You should add all NFS clients to access the shared folder.

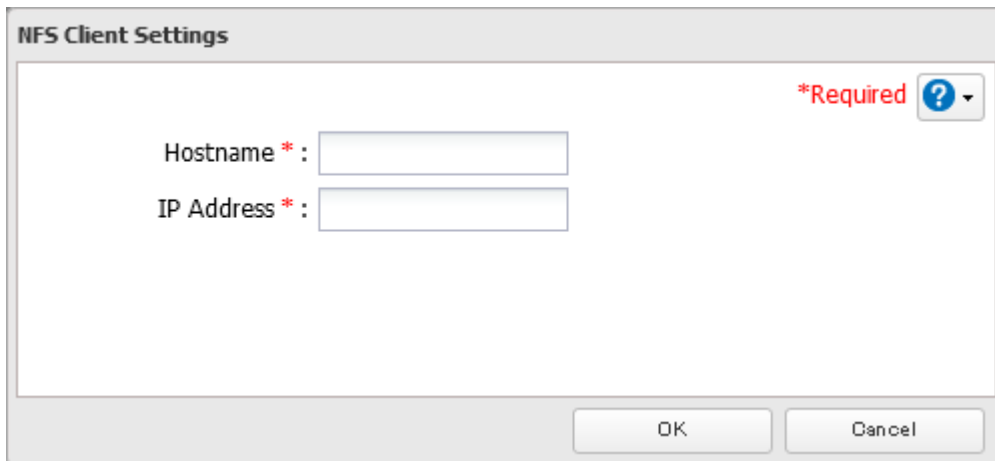

10 Click the *Rules* tab, then click *Create*.

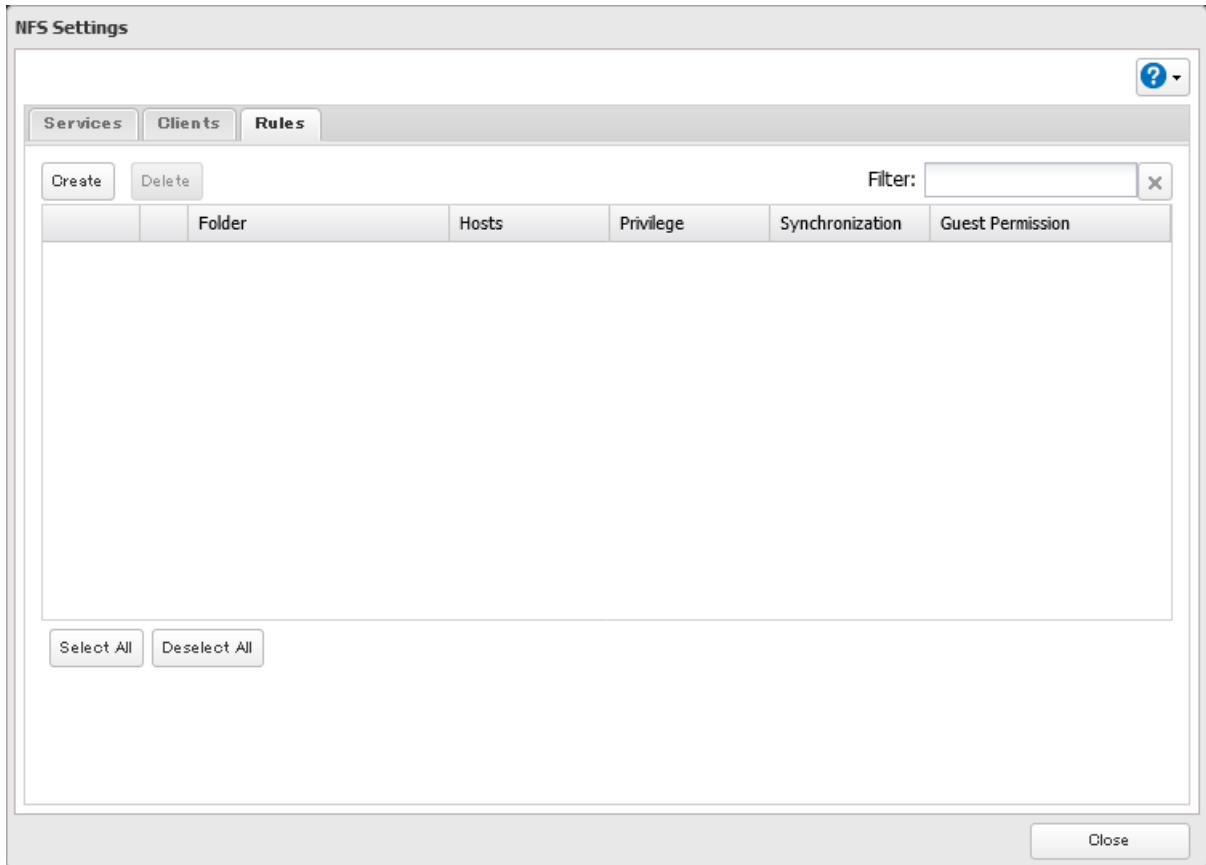

11 Choose the folder to restrict access to, and enter the clients that will have restricted access into the “Hosts” field. Clients may be entered by hostname, IP address, or IP address range. Wildcards are supported. Separate multiple entries with commas. You may assign read-only or read and write access to the listed clients. Rules override any settings made from the *Services* tab.

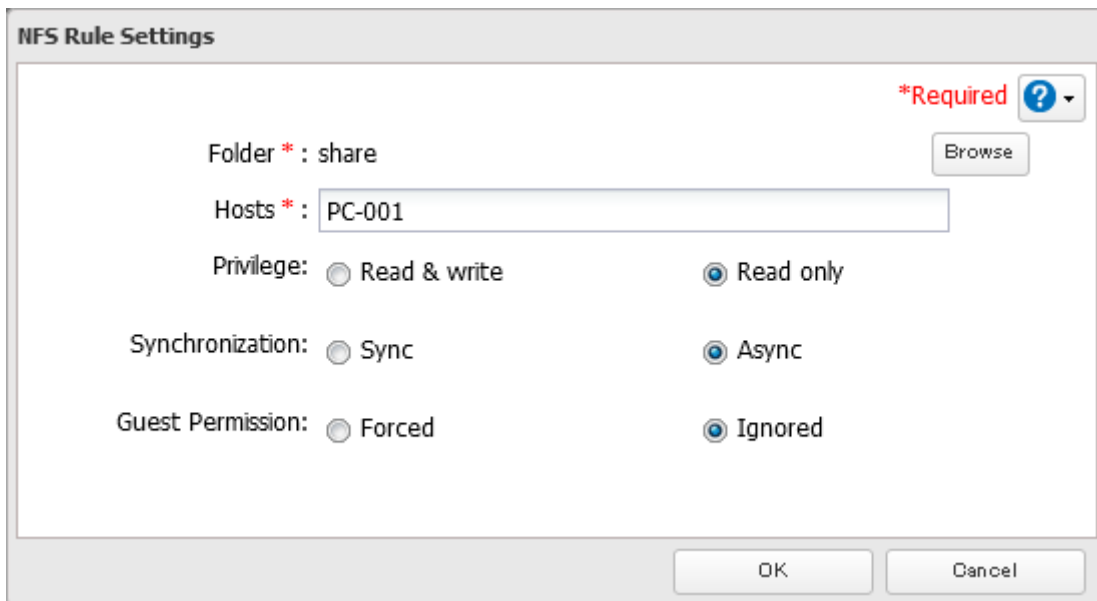

12 Click *OK*. The process is complete once you close the confirmation window that appears.

Notes:

- To restrict NFS access to a specific network or client, navigate to *File Sharing > NFS > Services* and click *Edit*. Enter the address of the network. For example, if your local network subnet has a router at 192.168.1.1 and clients with IP addresses in the range from 192.168.1.2 through 192.168.1.48 with subnet mask 255.255.255.0, then the “Public Network Address” would be 192.168.1.0 and the “Public Subnet Mask” would be 255.255.255.0. This would mean that only clients on this local network would be able to access the NFS share. If the default settings are used (0.0.0.0 for both the public network address and the public subnet mask), then access to the NFS share will not be restricted.
- If you configure “Guest Permission” to “Forced” on the screen after navigating to *Rules > Add*, the user ID and group ID should be 65534 when the data is written from NFS clients; this is recommended for SMB and other protocols as well. If the TeraStation only enables the NFS connection, select “Ignored” instead.
- Be aware that some NFS clients may be able to access via NFS although the clients do not exist in the allowed NFS client list.

NFS Mount Commands

Enter the mount command to access the shared folder from the NFS client. The mount command depends on your operating system. The examples below assume that IP address of your TeraStation is 192.168.11.10, “/mnt/array1/share” is the desired NFS path, and “/mnt/nas” or drive letter “z” is the mount point.

For Linux:

```
mount -t nfs 192.168.11.10:/mnt/array1/share /mnt/nas
```

For Windows Service for Unix 3.5:

```
mount 192.168.11.10:/mnt/array1/share z:
```

Note: A shared folder whose folder name contains multibyte characters cannot be accessed.

For Solaris 10:

```
mount -F nfs 192.168.11.10:/mnt/array1/share /mnt/nas
```

For macOS:

```
sudo mount -t nfs -o resvport 192.168.11.10:/mnt/array1/share /mnt/nas
```

Offline Files for Windows

The “offline files” feature that is included with many versions of Windows can be used with files on the TeraStation. You will be able to work on files stored on the TeraStation even when your PC is disconnected from the network. When you next connect to the network, the updated files are written and synchronized. Follow the procedure below to configure offline files.

- 1 From Settings, click *File Sharing*.

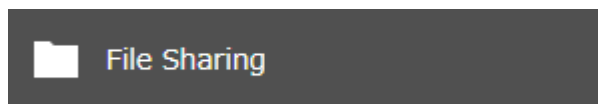

- 2 Click the settings icon () to the right of “Folder Setup”.



3 Click the shared folder for offline files.

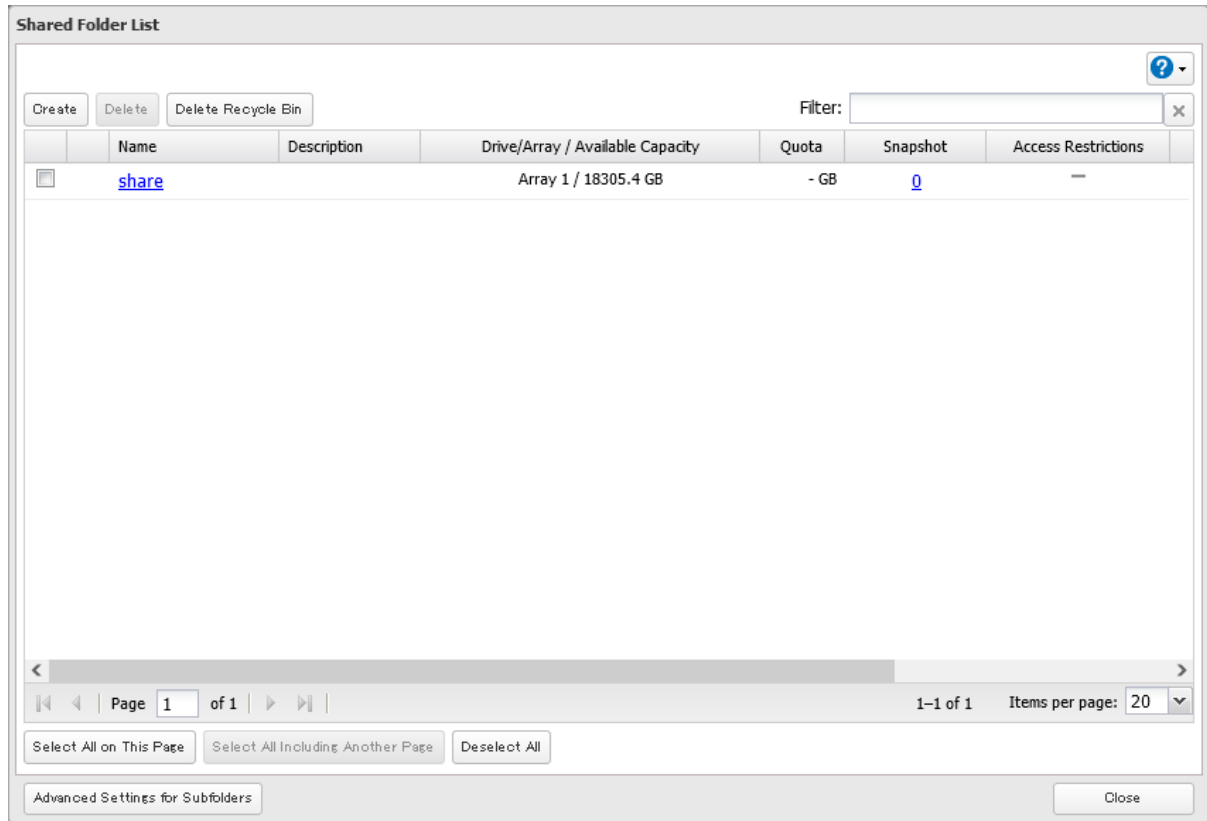

4 Choose either "Manual caching of documents", "Automatic caching of documents", or "Automatic caching of programs and documents" on the *Option 1* tab, then click OK.

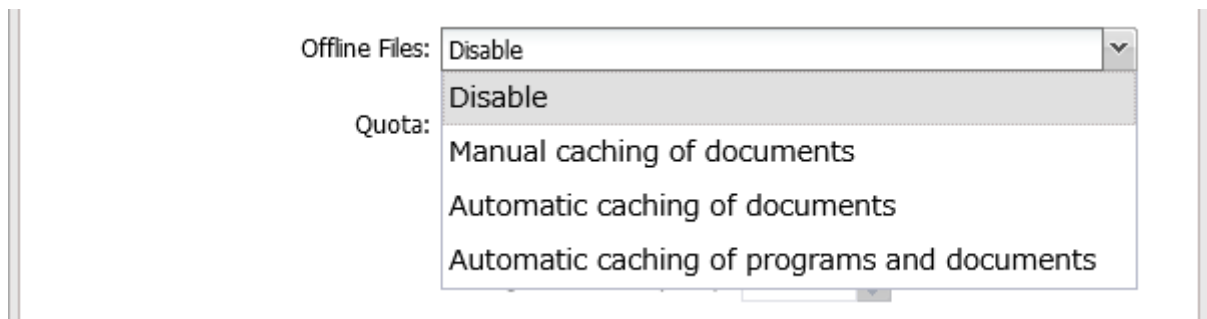



Manual caching of documents: User selects files that are cached.

Automatic caching of documents: Opened files can be cached locally for offline use. Previous versions of files that are not synchronized are automatically replaced by the latest versions.

Automatic caching of programs and documents: Opened files can be cached locally for use offline. Previous versions of files and applications executed on the network that are not synchronized are automatically replaced by the latest version of the files and applications.

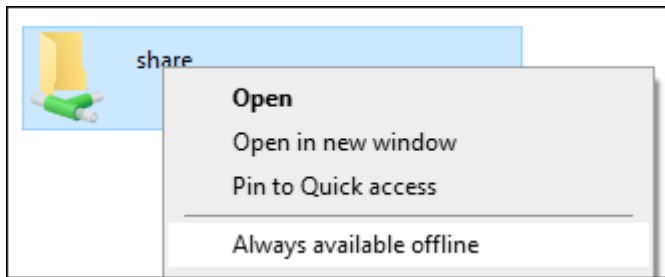
- 5** From File Explorer, right-click the icon of the shared folder on the TeraStation for which you have set the offline feature, then click *Always available offline*.



- 6** The process is complete when the shared folder icon is changed to .

When the configuration of offline settings and synchronization settings is finished, synchronization will begin. If the computer is disconnected from the network after synchronization is finished, the offline file function can be used. Offline files can be accessed by the original Universal Naming Convention (UNC) where the data was saved.

Notes:

- If you cannot access offline files, try the following procedure:
 - (1) Reconnect the computer to the network.
 - (2) From Control Panel, change the view to the icon view and click *Sync Center*. Click *Sync All* to synchronize all offline files.
 - (3) Disconnect the computer from the network and verify that you can access offline files.
- If you have configured the recycle bin for the shared folder, temp files may be created in the recycle bin.

Chapter 5 RAID Modes and Drive Management

Available RAID Modes

The TeraStation supports multiple types of RAID. The type of RAID arrays available for use depends on how many drives are installed on your TeraStation.

Notes:

- If you change the RAID mode, all data on the array is deleted. This is true for every procedure in this chapter. Always back up any important data before performing actions that affect your RAID array.
- Some arrays will allow you to change the RAID mode without losing data by adding drives. To change a RAID mode by adding drives to the existing array, refer to the [“Managing a RAID Array Without Deleting Data”](#) section below.
- Drive capacity is displayed in Settings in actual gigabytes. The Properties window in Windows may show GiB instead, which will be a smaller number.
- If the TeraStation is restarted or shut down while changing the RAID mode, the message will change from I46 or I47 to I18.
- RAID 5, 6, and 10 are only available for TeraStation models that allow three or more drives to be inserted. Please check Settings on your model before changing the RAID mode.

JBOD

This mode treats the drives inside the TeraStation as individual drives. The usable space is equal to the total capacity of all drives on the TeraStation. If any of the drives fail, then all data on that drive will be lost.

RAID 6

A RAID 6 array is available for TeraStations with four or more drives. RAID 6 combines four or more drives into a single array. The usable space is equal to the sum of the capacity of all drives minus the capacity of two drives. For example, if four drives are combined into a RAID 6 array, the usable space is the sum of the capacity of two drives. If up to two drives in the array fail, you can recover data by replacing any failed drives. If three or more drives fail, then all data in the array will be lost.

RAID 5

A RAID 5 array is available for TeraStations with three or more drives. RAID 5 combines three or more drives into a single array. The usable space is equal to the sum of the capacity of the drives minus the capacity of one drive. For example, if four drives are combined into a RAID 5 array, the usable space is the sum of three drives. If one drive in the array fails, you can recover data by replacing the failed drive. If two or more drives fail at the same time, then all data in the array will be lost.

RAID 1

A RAID 1 array combines two or more drives into a mirrored array. The usable space is equal to the capacity of a single drive. Identical data is written to each drive. If a drive fails, data can be recovered by replacing the failed drive. As long as one drive in the array remains undamaged, all data in the array can be recovered.

RAID 0

A RAID 0 array combines two or more drives into a single array. The usable space is equal to the total capacity of all drives in the array. This simple RAID mode offers faster performance than RAID modes that include parity. If a single drive in the array fails, then all data in the array will be lost.

RAID 10

A RAID 10 array is available for TeraStations with four or more drives. In this mode, mirrored pairs of drives in RAID 1 arrays are combined into a RAID 0 array. The usable space is equal to the capacity of the smallest drive multiplied by the number of drives divided by two.

The default RAID mode is RAID 6.

Working with RAID Arrays

Using JBOD

With JBOD, each drive on the TeraStation is addressed separately. To put drives in an array into JBOD, follow the procedure below.

- 1 From Settings, click *Storage*.



- 2 Click the settings icon () to the right of "RAID".



- 3 Click the array to delete.

RAID Array List



Name	RAID Mode	Status	Total Capacity	Used Capacity	% Used	Fil
Array_1	RAID 1	Normal	1830.7 GB	2 GB	0.11%	Bt
Array_2		No RAID array is configured.				
Array_3		No RAID array is configured.				
Array_4		No RAID array is configured.				
Array_5		No RAID array is configured.				
Array_6		No RAID array is configured.				

4 Click *Delete RAID Array*.

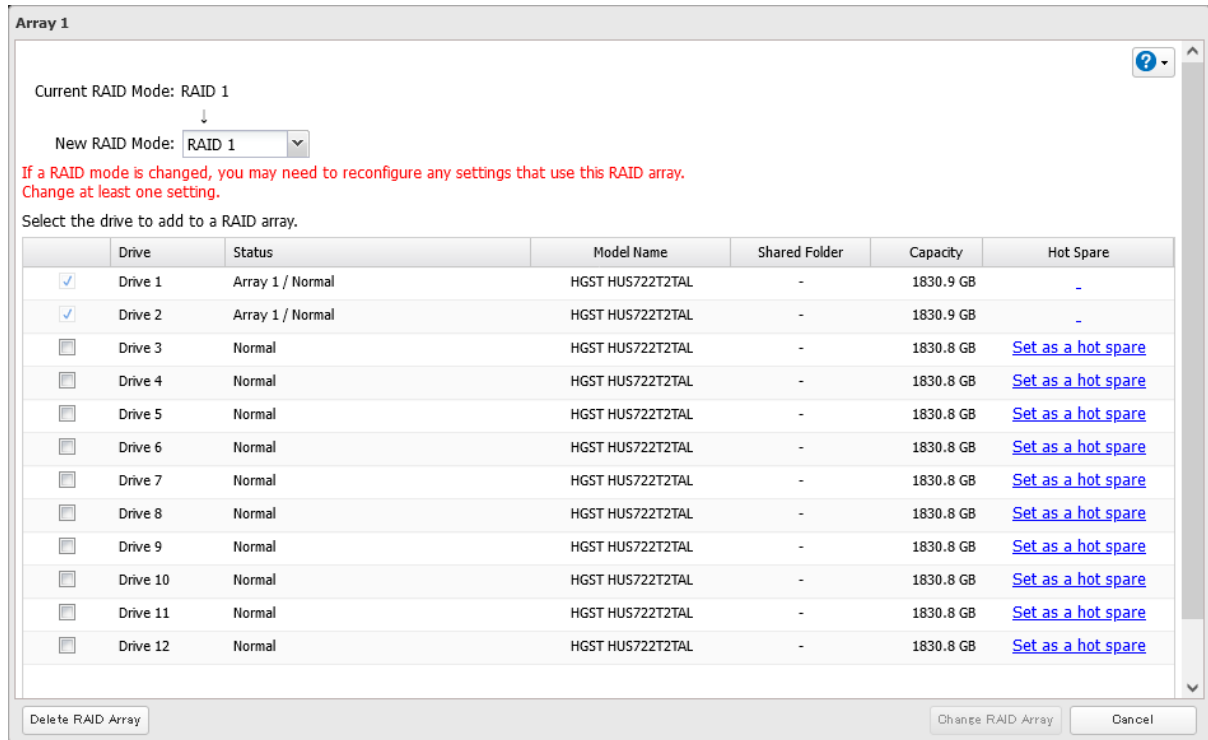

5 The “Confirm Operation” screen will open. Enter the confirmation number, then click *OK*.

6 The process is complete once you close the confirmation window that appears.

When the drives are put into JBOD, next create a shared folder by referring to the [“Adding a Shared Folder”](#) section in chapter 4.

Creating a RAID Array

Before creating a new RAID array, first put the drives into JBOD by referring to the [“Using JBOD”](#) section above. Then, follow the procedure below.

1 From Settings, click *Storage*.



2 Click the settings icon () to the right of “RAID”.



3 Choose a RAID array.

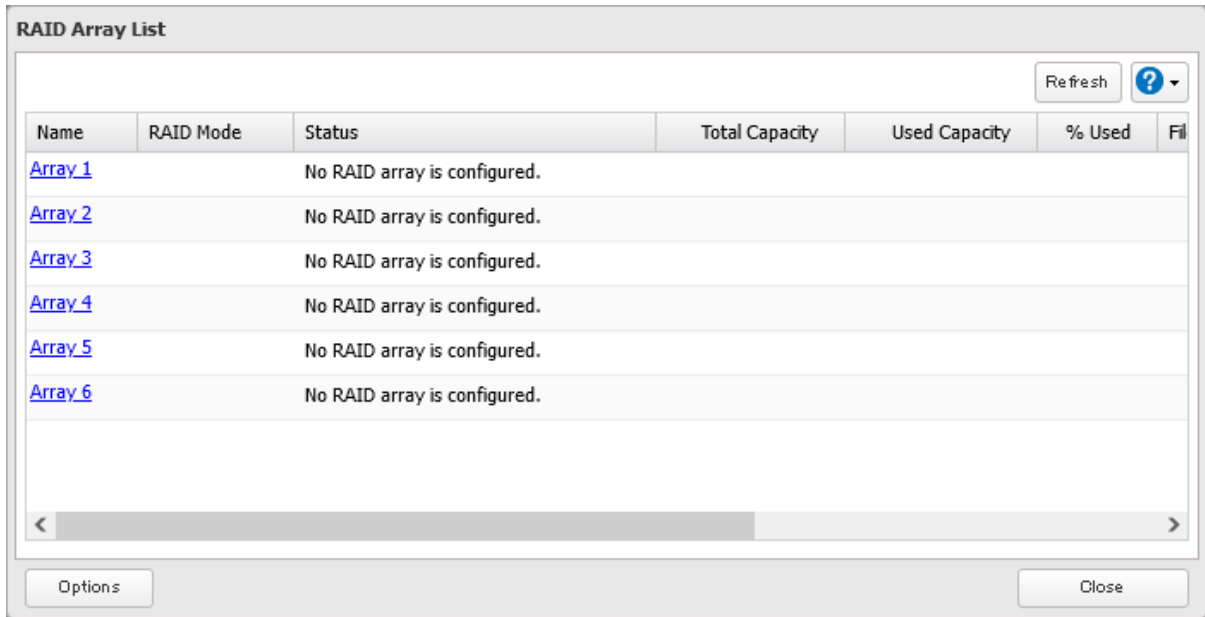

4 Select a RAID mode and the drives to be used, then click *Create RAID Array*.

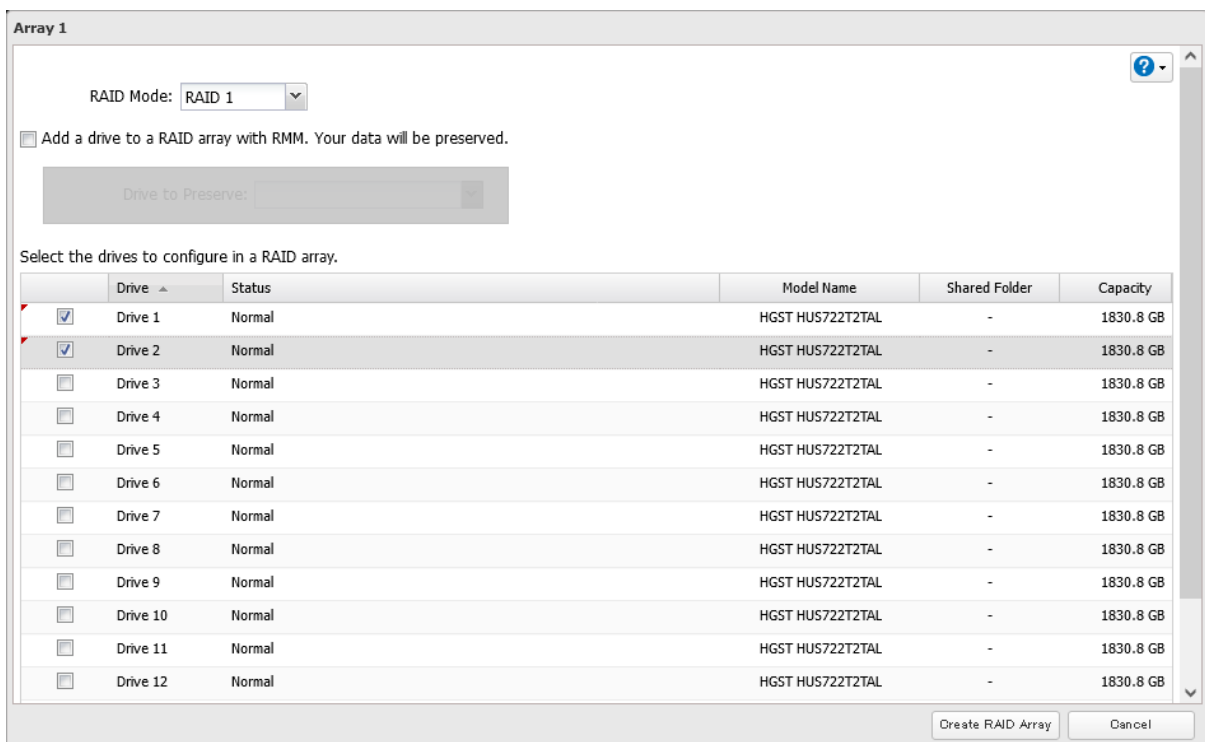

5 Depending on the RAID configuration, the message will appear. Read the message carefully and click Yes to proceed.

6 The "Confirm Operation" screen will open. Enter the confirmation number, then click OK.

7 The process is complete once you close the confirmation window that appears.

When the RAID array has been created, next create a shared folder by referring to the ["Adding a Shared Folder"](#) section in chapter 4.

Shutting Down the TeraStation Automatically If an Error Occurs

This function will shut down the TeraStation automatically if an error occurs on a drive that is used in a redundant RAID array. To configure auto shutdown, follow the procedure below.

- 1 From Settings, click *Storage*.



- 2 Click the settings icon () to the right of "RAID".



- 3 Click *Options*.

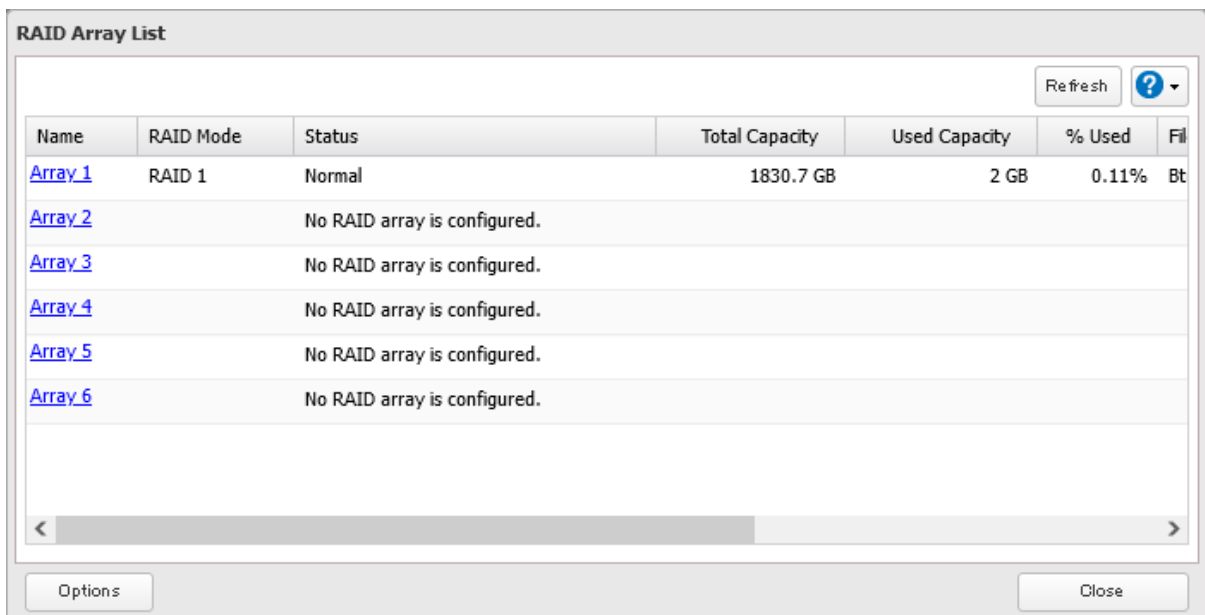

- 4 Click *Edit* and change the "Error Behavior" option to "Shut down", then click *OK*.

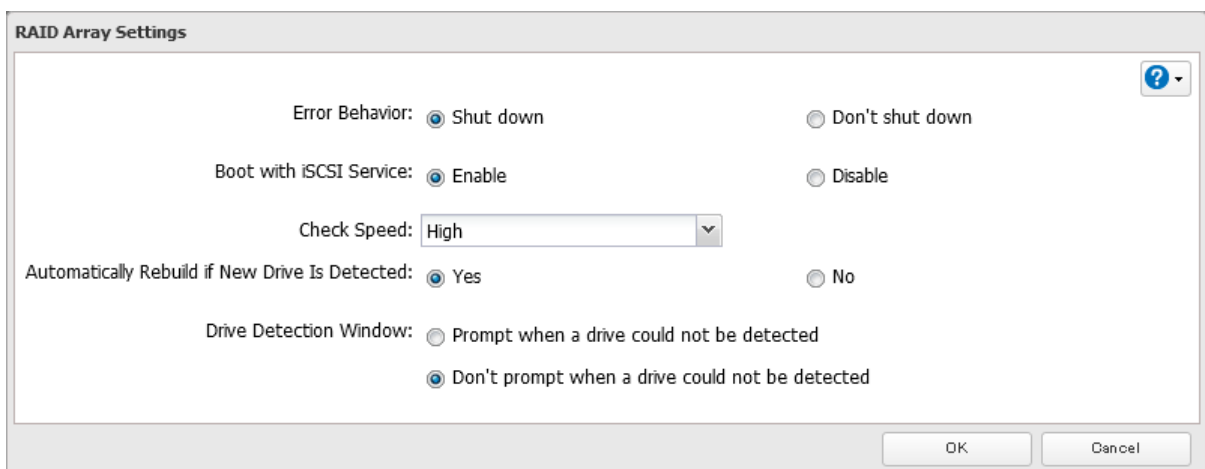

- 5 The process is complete once you close the confirmation window that appears.

Rebuilding the RAID Array Automatically

If auto RAID rebuild is enabled, RAID arrays will rebuild automatically after a failed drive is replaced. You may enable or disable auto RAID rebuild by following the procedure below.

- 1 From Settings, click *Storage*.



- 2 Click the settings icon () to the right of "RAID".

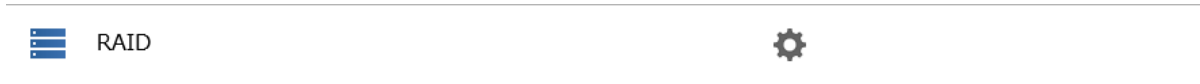

- 3 Click *Options*.

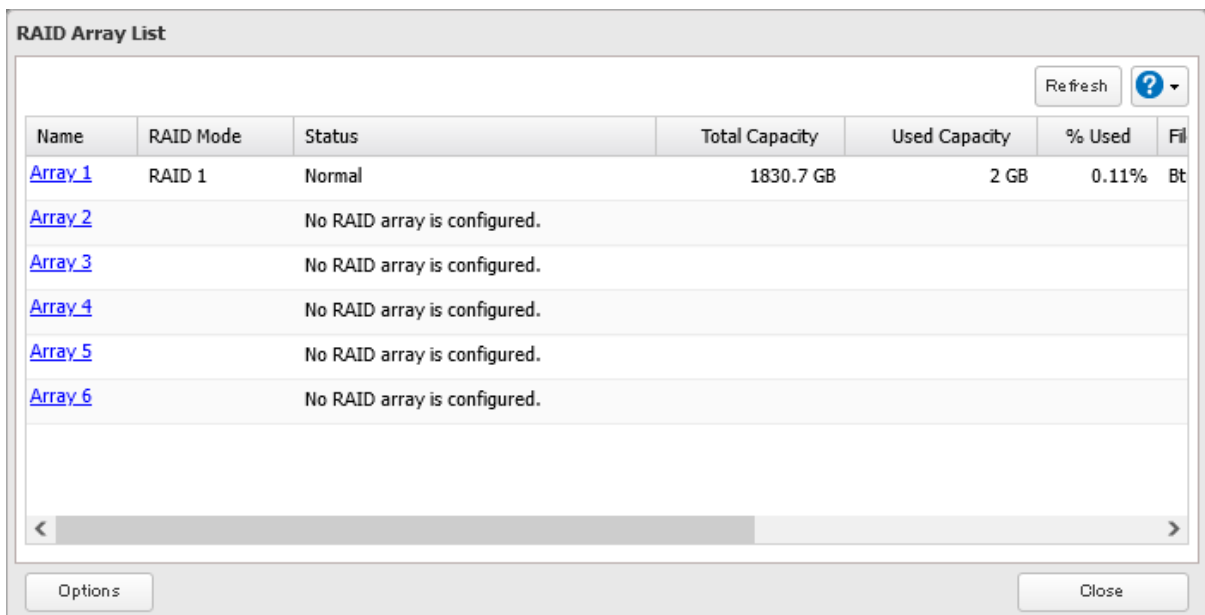

- 4 Click *Edit* and change the "Automatically Rebuild if New Drive Is Detected" option to "Yes", then click *OK*.

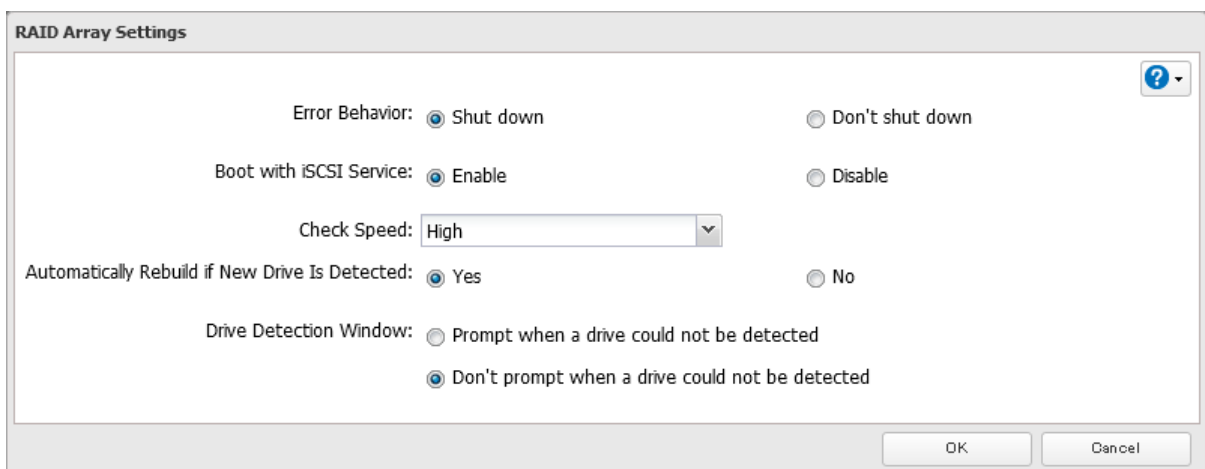

5 Read the message carefully and select the checkbox, then click *OK*.

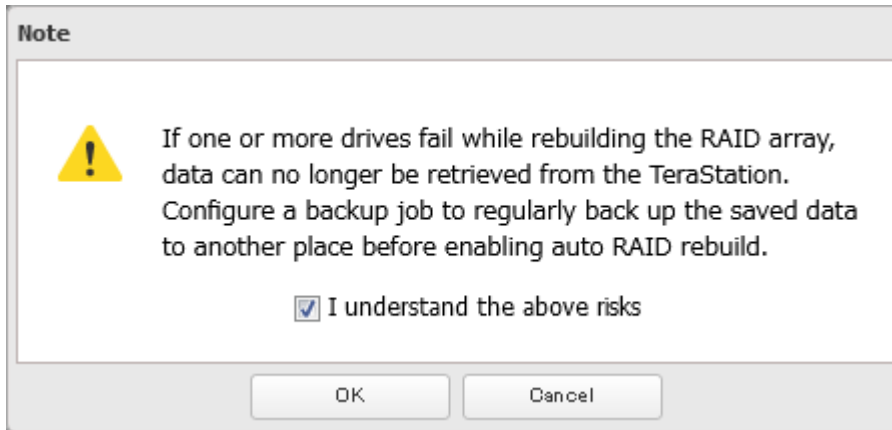

6 The process is complete once you close the confirmation window that appears.

Configuring Actions for If a Drive Used for the RAID Array Has Not Been Detected

You can configure actions to be taken by the TeraStation if a drive used for the RAID array cannot be mounted when booting.

Hiding the Confirmation Screen

Configure to display or hide the confirmation screen that showcases the actions for if a drive used for the RAID array cannot be mounted when booting. The confirmation screen is configured to appear by default. To hide the screen, follow the procedure below.

1 From Settings, click *Storage*.



2 Click the settings icon () to the right of "RAID".

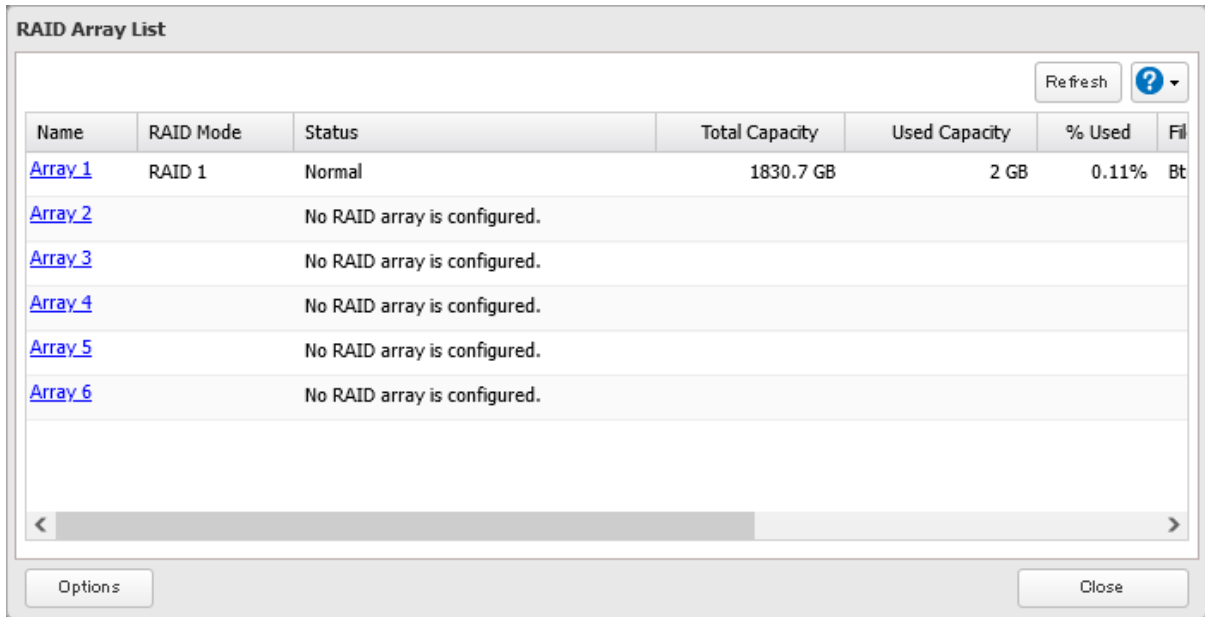
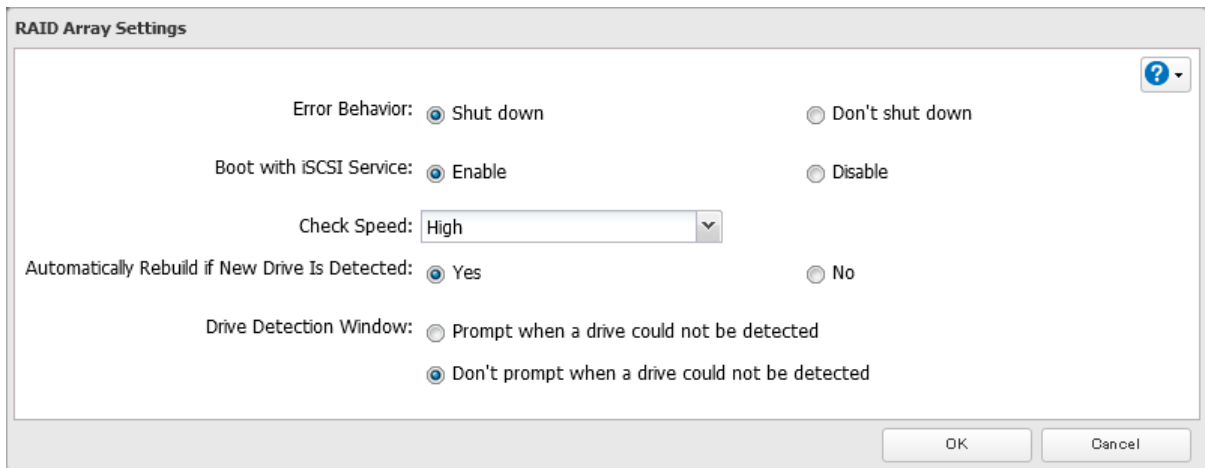

3 Click *Options*.**4** Click *Edit* and change the “Drive Detection Window” option to “Don't prompt when a drive could not be detected”, then click *OK*.**5** The process is complete once you close the confirmation window that appears.

If the confirmation screen is not set to appear, an undetected drive will automatically be dismounted from the TeraStation. If a redundant RAID mode is configured, the TeraStation will enter degraded mode. However, if RAID 0 is configured, the RAID array will become corrupted, resulting in data loss. It is recommended to proceed without changing settings that would prevent the confirmation screen from appearing.

Selecting the Action on the Confirmation Screen

When the confirmation screen is displayed, the following screen will appear after logging in to Settings if the drive used for the RAID array could not be mounted. Select the action to run when the screen appears.

Note

Drives currently in use in RAID array 1 could not be detected.

Undetected Drives: 2

Note: Depending on the RAID array configuration, undetected drives may not be fully listed. Before selecting the action to run, refer to the [user manual](#) on whether your RAID array configuration matches the situation.

Select the action to perform.

Restart the TeraStation and redetect the drives

Shut down the TeraStation and reconnect the drives

Dismount the undetected drives and turn on the TeraStation

Warning: This action will put the RAID array into degraded mode or have it become corrupted. Because of this, it will take time for the array to recover from degraded mode, otherwise data may be lost. We strongly recommend selecting another action before trying this one.

Conditions and Corrective Actions If Undetected Drives Aren't Displayed Properly

Even when you configure the NAS to show the confirmation screen if a drive being used for the RAID array cannot be mounted, undetected drives will not be displayed under the following conditions. If you are using any of the RAID array configurations below, follow the corrective procedure.

Conditions	Corrective Actions
RAID 10 has been configured.	<ol style="list-style-type: none"> 1 Refer to the “Selecting the Action on the Confirmation Screen” subsection above on how to access the confirmation screen. 2 Select “Shut down the TeraStation and reconnect the drives” and click <i>Execute</i>. 3 After the TeraStation shuts down, confirm that all drives have been inserted properly. 4 Press the power button to power on the TeraStation. 5 Log in to Settings and make sure the confirmation screen doesn't appear.
Multiple arrays have been configured.	

Configuring a Hot Spare

If you have a hot spare configured and an array fails, the TeraStation immediately switches over to the hot spare. To use a hot spare, you need a RAID 1 or RAID 5 array and an extra drive that's not part of an array.

Notes:

- All data on the hot spare drive is deleted when it is configured as a hot spare and again when it changes from a spare to a drive in the array.

- The hot spare drive will be used for all RAID arrays, no matter which RAID array configurations are implemented. If multiple RAID arrays are configured and one of the drive fails, the malfunctioning drive will automatically be replaced by the hot spare.

For example, there are two arrays with RAID configured and the first array is selected to configure the hot spare in the following procedure, the hot spare can also be used by another array if a drive on the second RAID array fails.

1 From Settings, click *Storage*.



2 Click the settings icon () to the right of "RAID".



3 Choose a RAID array.

RAID Array List

?

Name	RAID Mode	Status	Total Capacity	Used Capacity	% Used	Fill
Array_1	RAID 1	Normal	1830.7 GB	2 GB	0.11%	Bt
Array_2		No RAID array is configured.				
Array_3		No RAID array is configured.				
Array_4		No RAID array is configured.				
Array_5		No RAID array is configured.				
Array_6		No RAID array is configured.				

4 Click *Set as a hot spare*.

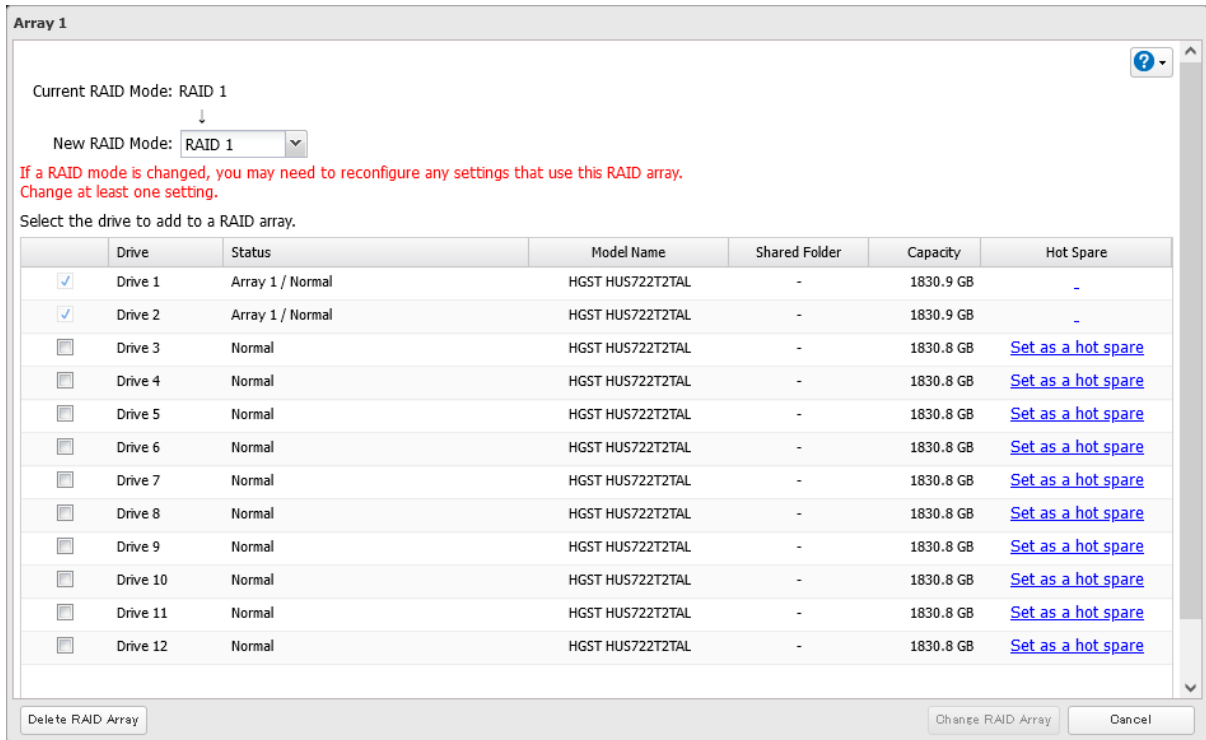

5 Read the message carefully and select the checkbox, then click *OK*.

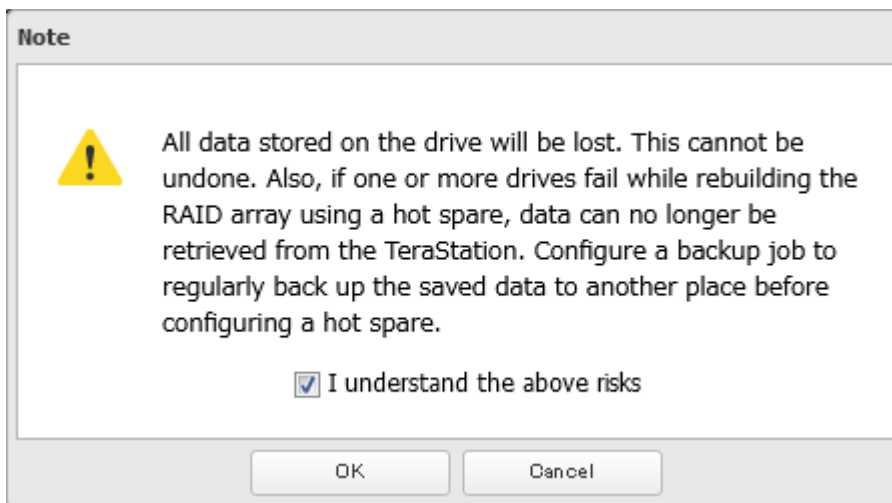

6 The “Confirm Operation” screen will open. Enter the confirmation number, then click *OK*.

7 The process is complete once you close the confirmation window that appears.

Note: To turn the hot spare back to a normal drive, choose *Set as a normal drive*.

Managing a RAID Array Without Deleting Data

You can manage a RAID array without erasing data on the drives by using RMM (RAID Mode Manager).

Note: RMM can be used to expand an array by only one drive per operation. To expand by two or more drives, RMM must be activated multiple times. For example, if you want to create a RAID 6 array by adding two drives, change the RAID mode to RAID 5 first using one drive, then change it to RAID 6 using another drive.

The following chart explains the transition status of drives after using RMM. The “n” in the chart below refers to the number of drives that make up the RAID array.

Current Drive Status	New RAID Mode	Capacity	Redundancy (Drive Failure Resistance)
JBOD	RAID 1	No increase	Improve (1 drive)
RAID 1	RAID 1	No increase	Improve ($n - 1$ drives)
	RAID 5	Increase	No change (1 drive)
RAID 5	RAID 5	Increase	No change (1 drive)
	RAID 6	No increase	Improve (2 drives)
RAID 6	RAID 6	Increase	No change (2 drives)

If using a TeraStation model that currently has unoccupied drive slots, such as in the case of partially-populated models, follow the procedure below to add new drives first. Otherwise, refer to the procedures in this section to configure the RAID array.

Adding a Drive

The procedure for adding a new drive will vary depending on your device.

- 1** Push the drive's unlock button for the empty slot and swing the lock mechanism out.
- 2** Pull out the drive cartridge and remove it from the TeraStation.
- 3** Insert the new drive (sold separately) into the empty slot with the lock mechanism remaining open and swing the lock back down until it clicks into place.
- 4** When the drive is recognized, the drive status LED will glow and the I32 message will appear as a notification.
- 5** From Settings, click *Storage*.



- 6** Click the settings icon () to the right of "Drives".



7 Select the inserted new drive and click *Format Drive*.

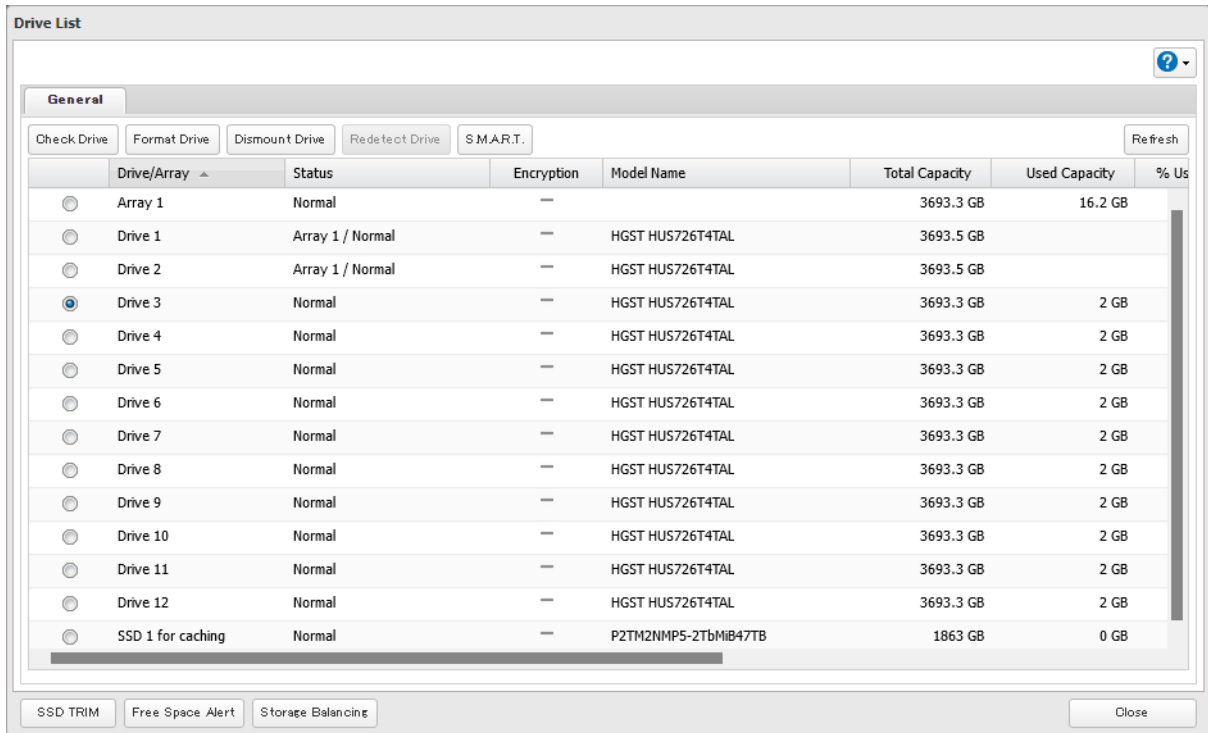

8 Select a file system, then click *Format*.

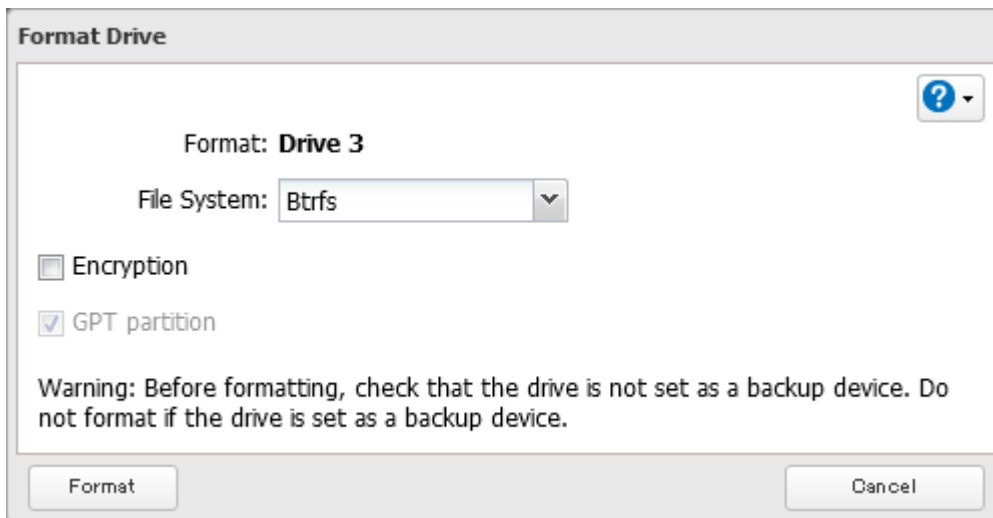

9 The "Confirm Operation" screen will open. Enter the confirmation number, then click *OK*.

10 The process is complete once you close the confirmation window that appears.

Drives That Are Currently in JBOD

To use RMM for drives in JBOD, you must have at least two drives available in JBOD. Follow the procedure below.

1 From Settings, click *Storage*.



2 Click the settings icon () to the right of “RAID”.



3 Choose a RAID array.

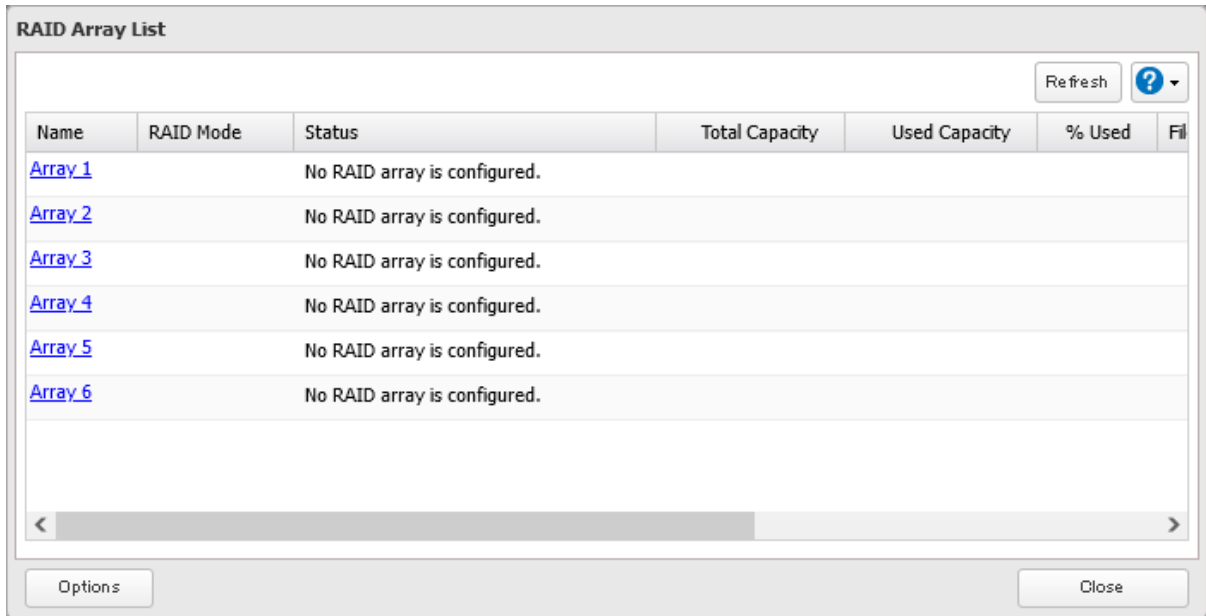

4 Set the RAID mode to “RAID 1”.

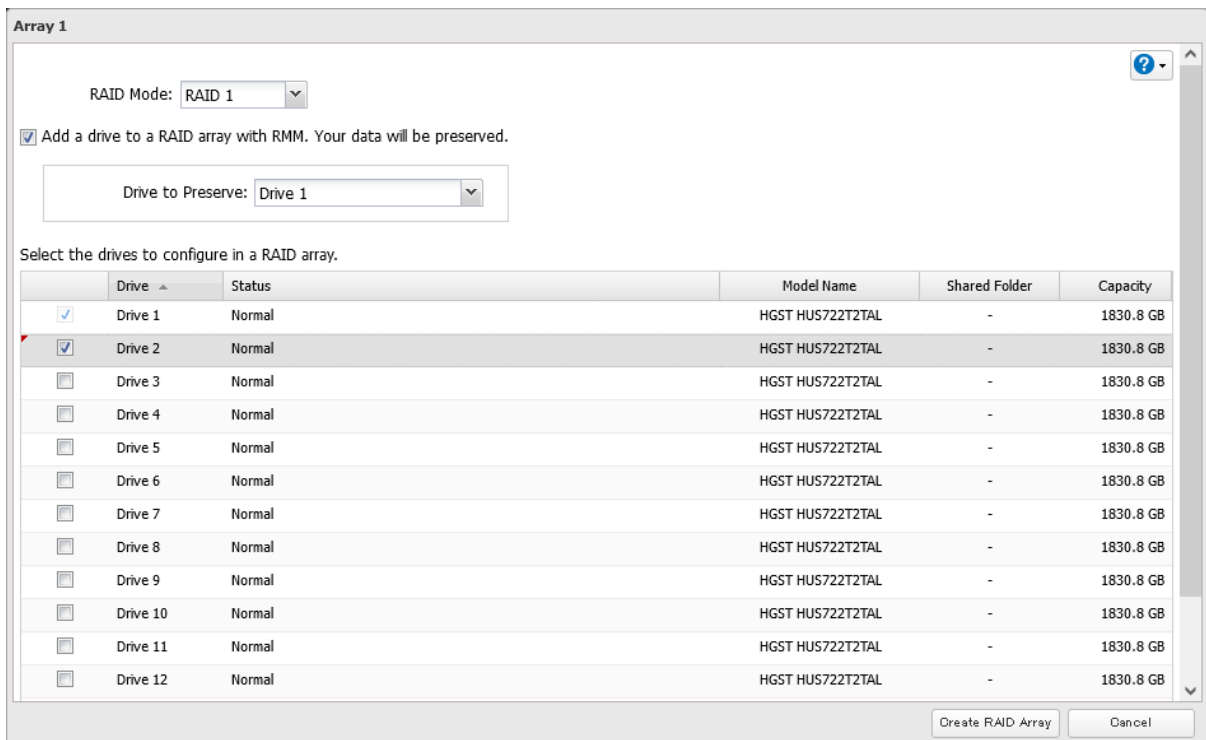

5 Select the “Add a drive to a RAID array with RMM. Your data will be preserved.” checkbox.

6 Select the drive whose data will be saved from the drop-down list.

- 7** Select the drive to add to the RAID array.
- 8** Click *Create RAID Array*.
- 9** The “Confirm Operation” screen will open. Enter the confirmation number, then click *OK*.
- 10** The process is complete once you close the confirmation window that appears.

Drives That Are Currently in RAID 1, 5, or 6

To use RMM for redundant RAID arrays (RAID 1, 5, or 6), you must have at least one drive available in JBOD. Follow the procedure below.

- 1** From Settings, click *Storage*.



- 2** Click the settings icon () to the right of “RAID”.



- 3** Choose a RAID array.

RAID Array List



Name	RAID Mode	Status	Total Capacity	Used Capacity	% Used	Fill
Array 1	RAID 1	Normal	1830.7 GB	2 GB	0.11%	Bt
Array 2		No RAID array is configured.				
Array 3		No RAID array is configured.				
Array 4		No RAID array is configured.				
Array 5		No RAID array is configured.				
Array 6		No RAID array is configured.				

- 4** Select one drive to add to the RAID array. If changing the RAID mode, choose the desired mode for the array from the drop-down list. Otherwise, keep the current RAID mode as is.

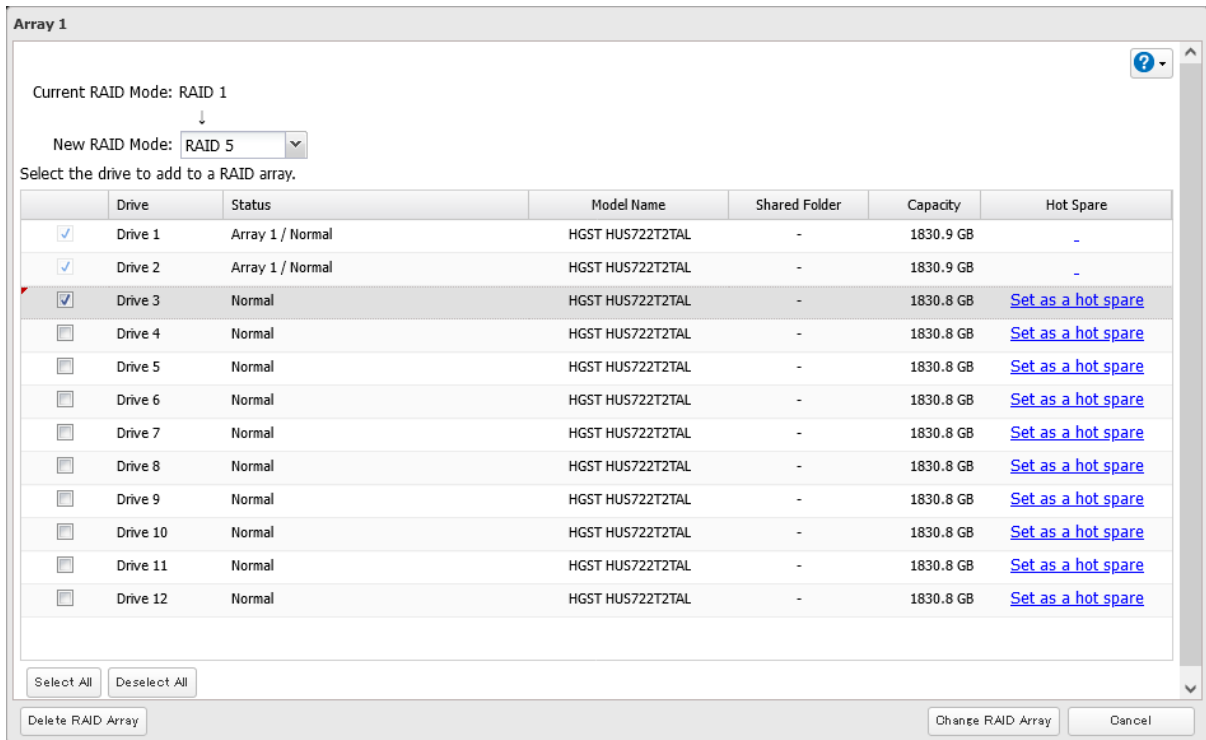

- 5** Click *Change RAID Array*.

- 6** The “Confirm Operation” screen will open. Enter the confirmation number, then click *OK*.

- 7** The process is complete once you close the confirmation window that appears.

RAID Scanning

A RAID scan checks your RAID array for bad sectors and if it finds any, it automatically repairs them. Arrays other than RAID 0 are supported. For best results, run RAID scans regularly.

- 1** From Settings, click *Storage*.



- 2** Move the RAID scanning switch () to the  position to enable RAID scanning.



- 3** Click the settings icon () to the right of “RAID Scanning”.



4 Click *Edit* and select when to run the scan, then click *OK*.

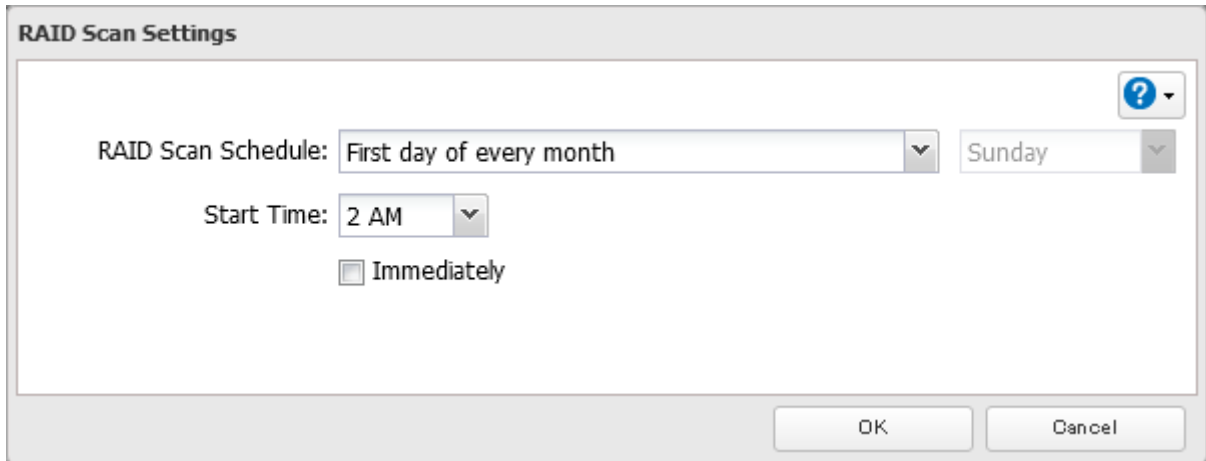

5 The process is complete once you close the confirmation window that appears.

Notes:

- Select the “Immediately” checkbox to run a RAID scan immediately.
- To stop a RAID scan, click *Cancel RAID Scan*.
- To prevent RAID scanning from impacting TeraStation performance, we recommend scheduling it so the process runs while the TeraStation is not being accessed.

Configuring Low Drive Space Alerts

You can configure the TeraStation to notify you when it is running low on free space, either by having a message displayed on the Dashboard in Settings or having the TeraStation send you an email notification. This function is applicable to internal drives, RAID arrays, and LVM volumes on the TeraStation.

Note: If you have configured low drive space alerts and created iSCSI volumes on the LVM-enabled area, the I65 message will appear as a notification.

1 From Settings, click *Storage*.



2 Click the settings icon () to the right of “Drives”.



3 Click *Free Space Alert*.

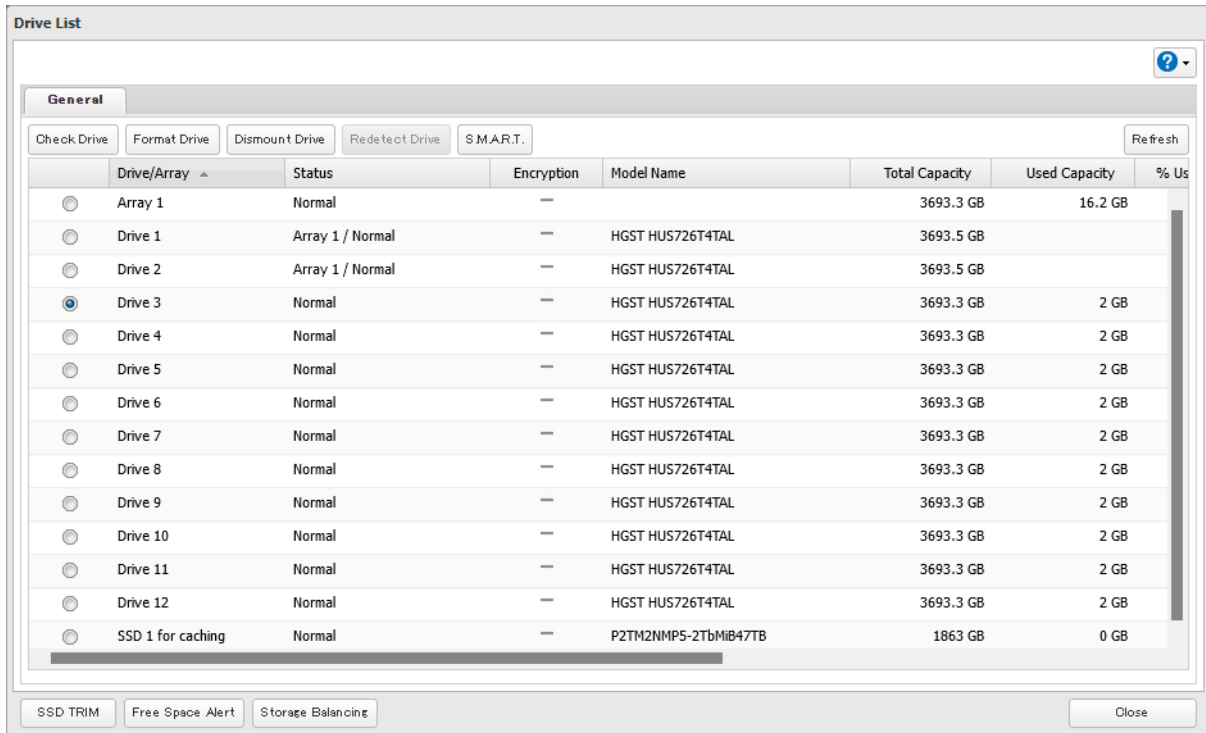

4 Enable “Free Space Alert” and enter the threshold value, then click *OK*.

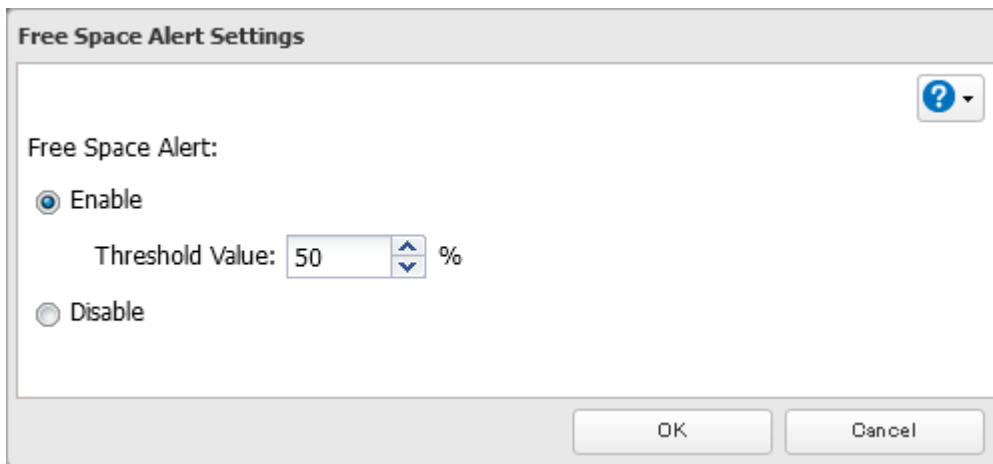

5 The process is complete once you close the confirmation window that appears.

The free space alert is now enabled. If the percentage of remaining free space on the TeraStation decreases past the threshold percentage, a notification will appear on the Dashboard in Settings. To configure free space alert email notifications, refer to the [“Email Notification”](#) section in chapter 11.

Storage Balancing

Storage balancing is a process that checks a volume for unnecessarily-allocated capacity and re-arranges data blocks, thus freeing up more unallocated space. This feature can be run to optimize storage capacity when drive space is low and may result in increased free space.

1 From Settings, click *Storage*.



2 Click the settings icon () to the right of "Drives".



3 Click *Storage Balancing*.

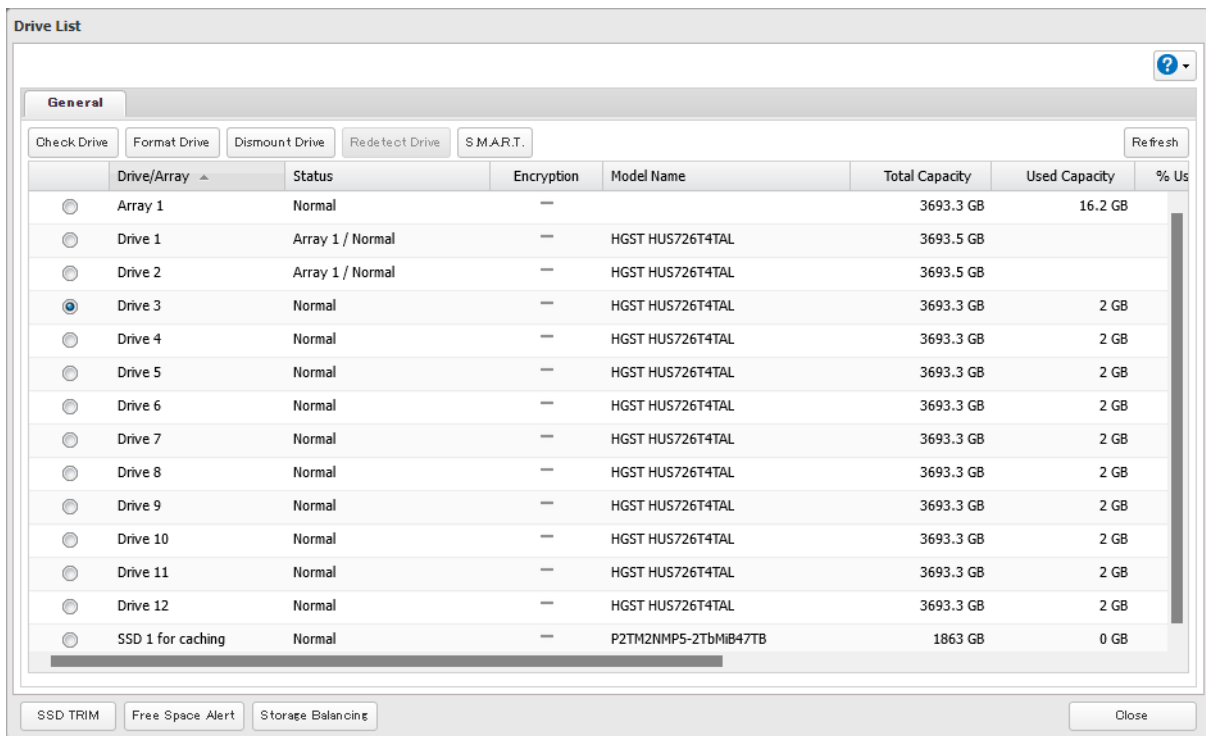

4 Enable "Storage Balancing" and select when to run the process, then click *OK*.

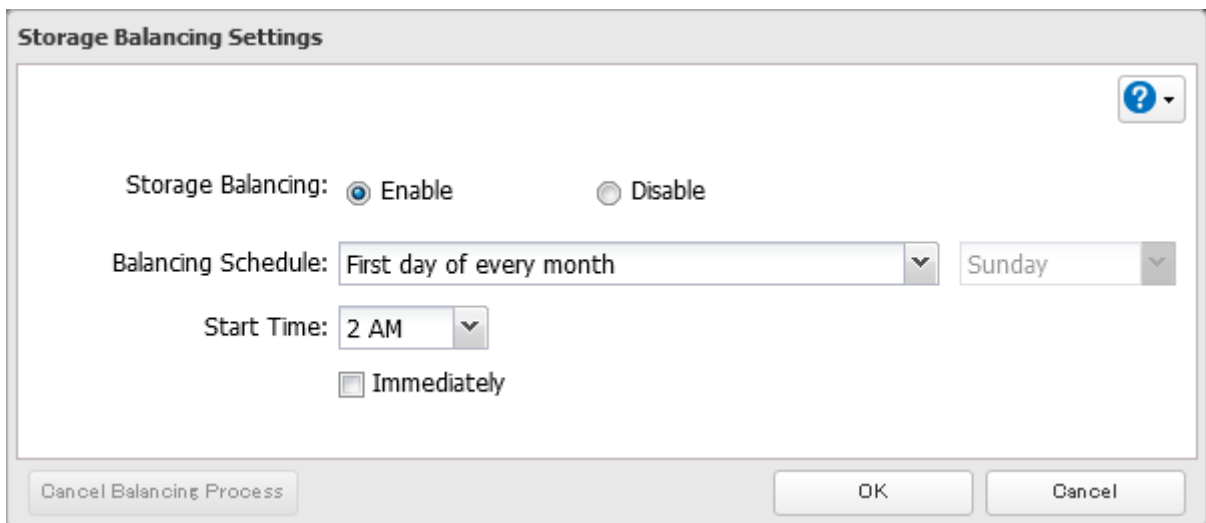

5 The process is complete once you close the confirmation window that appears.

Notes:

- Depending on your usage environment, the storage balancing process may take up to a week to complete.
- Select the “Immediately” checkbox to run storage balancing immediately.
- The storage balancing process may impact TeraStation performance. If you intend to run storage balancing regularly, we recommend scheduling it so the process runs while the TeraStation is not being accessed.
- If you need to stop the storage balancing process, such as if it is negatively impacting TeraStation performance, click *Cancel Balancing Process* to stop it.
- If any of the following operations are performed while the storage balancing process is running, some areas may not be re-arranged: restarting or shutting down the TeraStation, changing the RAID array via RMM, checking drives, editing NAS volumes. After performing any of the operations above, you can either run the storage balancing process immediately to re-arrange unallocated areas, or wait for the scheduled balancing process.

Adding an External Drive

Your TeraStation features multiple USB ports, and you can connect an external drive to any of these ports except for the USB 2.0 port. Once connected, it appears as a shared folder on the TeraStation. A formatted drive is detected automatically. Unformatted drives should be formatted. Some file systems can be formatted from Settings. Refer to the [“Compatibility”](#) chart below for which file extensions are supported and can be formatted from Settings. After a USB drive is recognized, the TeraStation adds “usbdisk x” to the shared folder list, where “x” is the USB port to which the drive is connected.

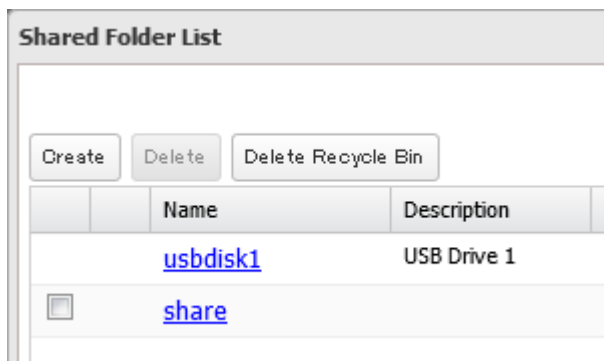

If a USB drive is unplugged without being dismounted first while the TeraStation is powered on, it may not be recognized properly when it is reconnected. If this occurs, restart the TeraStation and then reconnect the drive.

Compatibility

Supported file systems for external USB drives are below:

File Systems	Recommended Situation
Btrfs	Connecting to this TeraStation.
XFS	Connecting to another Buffalo NAS device.
Ext3 ^{*1,2}	Connecting to another Buffalo NAS device. XFS is recommended because the more files stored in one folder, the slower the performance. The available capacity will be less than the area formatted to XFS.
NTFS ^{*1}	Connecting to Windows computers. The NTFS-formatted drive can use many more functions of the operating system than an exFAT drive.
HFS Plus ^{*1,3,4}	Connecting to macOS computers. The HFS Plus-formatted drive can use many more functions of the operating system than an exFAT drive.
exFAT ^{*1}	Connecting to both Windows and macOS computers.
FAT32	Connecting to both Windows and macOS computers.

*1 This cannot be formatted from Settings.

*2 The available USB drive size is up to 16 TB.

*3 This is read-only from the TeraStation. Files on the USB drive can be copied to the TeraStation.

*4 This cannot be used if Apple Partition Map is used as the partition scheme when formatting.

Make sure only one device is connected to a USB port on the TeraStation. Note that only the first partition of a connected USB drive is mounted. Additional partitions are not recognized.

Notes:

- If your USB 3.0 drive is not reconfigured after rebooting the TeraStation, unplug and reconnect it.
- When copying a file that is over 100 MB to a FAT32-formatted USB drive using File Explorer, an error message may appear. In such a case, use an FTP or SFTP connection to copy the file.
- When copying files from a shared folder to a FAT32-formatted USB drive, the progress bar may not be displayed or the file copying may fail. Using a file system other than FAT32 is recommended for the USB drive.
- After connecting an RDX drive to the TeraStation, click *Redetect Drive* anytime.

Dismounting Drives

If the TeraStation is off, then any connected drives (internal or external) are already dismounted and may be unplugged safely from the unit. If the TeraStation is powered on, follow the appropriate procedure below to dismount any connected drives before unplugging them.

Notes:

- Do not dismount internal drives while a RAID array is rebuilding or RMM is being configured. If you do, data on the drives may be lost.
- To dismount an RDX cartridge from an RDX dock, first perform the dismount process either using the function button or from Settings, then press the eject button on the dock to disconnect the cartridge.
- While accessing files on a USB drive or if a USB drive has been set as a target folder for logs, the USB drive cannot be dismounted.
- When dismounting a USB drive, the file sharing service will restart so shared folders will become inaccessible temporarily.

1 From Settings, click *Storage*.



2 Click the settings icon () to the right of "Drives" to dismount an internal drive or "USB Drives" to dismount an external drive.



- 3** Select the drive to dismount and click *Dismount Drive*.

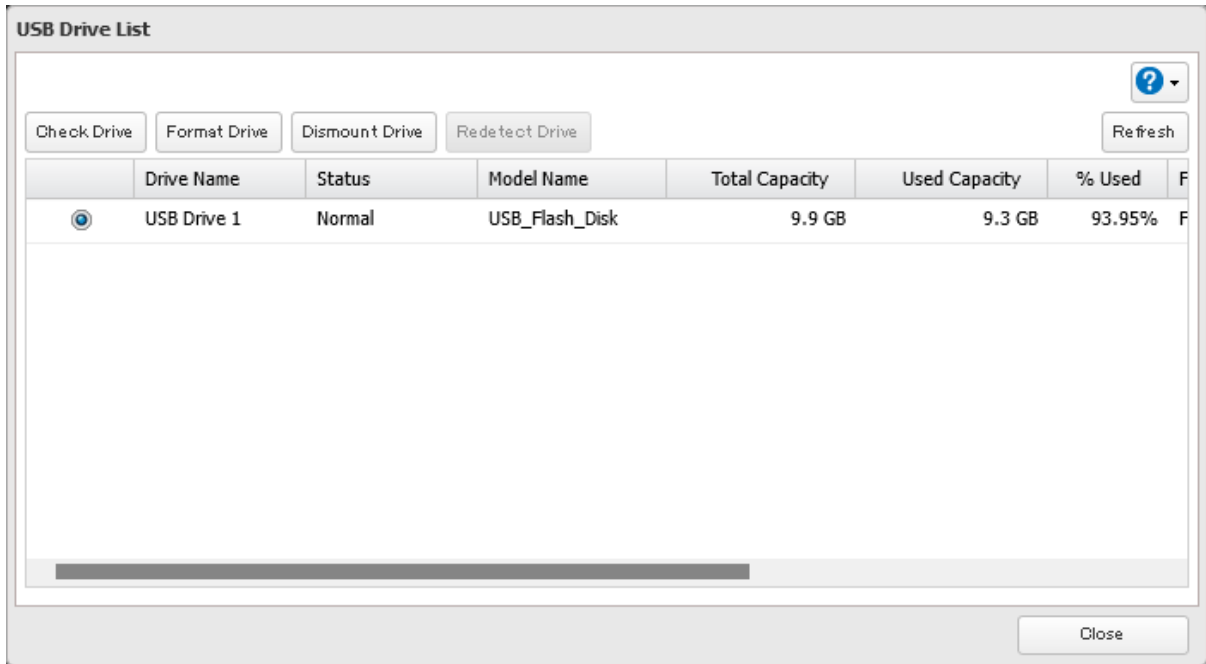

- 4** The "Confirm Operation" screen will open. Enter the confirmation number, then click *OK*.
- 5** The process is complete once you close the confirmation window that appears.

When the dismounting process is finished, it is safe to unplug the drive. Disconnect the drive from the TeraStation.
Note: To remount the drive, unplug it and wait for approximately three minutes, then plug it back in.

Checking Drives

A drive check tests the data on a drive on the TeraStation or one that is connected via USB for integrity. Detected errors are fixed automatically. With large drives, a drive check may run for many hours. Shared folders cannot be accessed during a drive check. Do not turn off the TeraStation until the drive check is finished. Follow the procedure below to run a drive check.

- 1** From Settings, click *Storage*.



- 2** Click the settings icon (⚙️) to the right of "Drives" to check an internal drive or "USB Drives" to check an external drive.

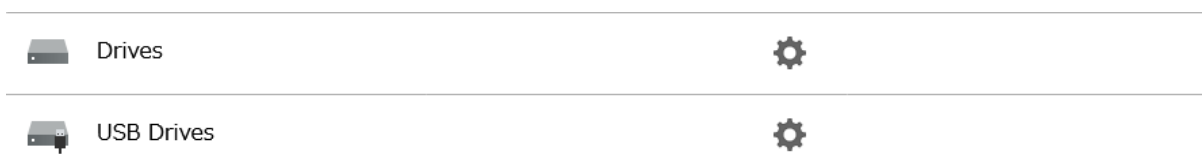

- 3** Select the drive or array to test, then click *Check Drive*.

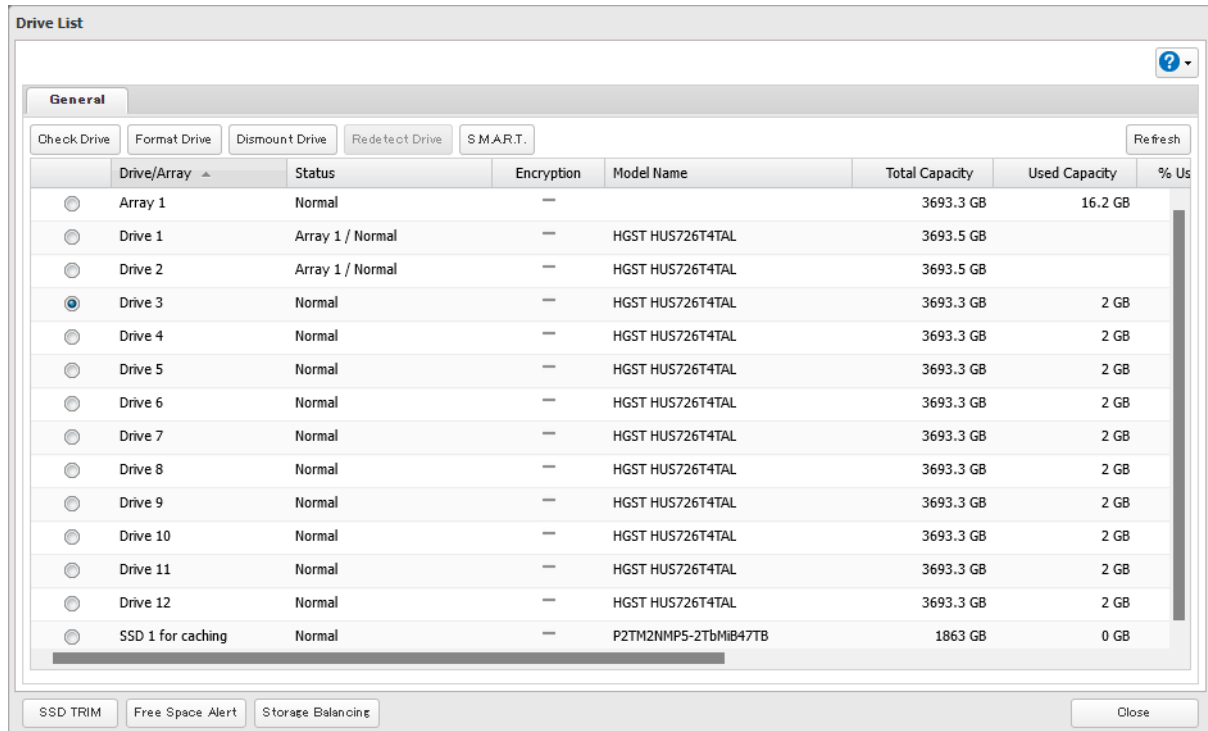

- 4** Click *Check*. You have the option of deleting information files from macOS during the check if desired.

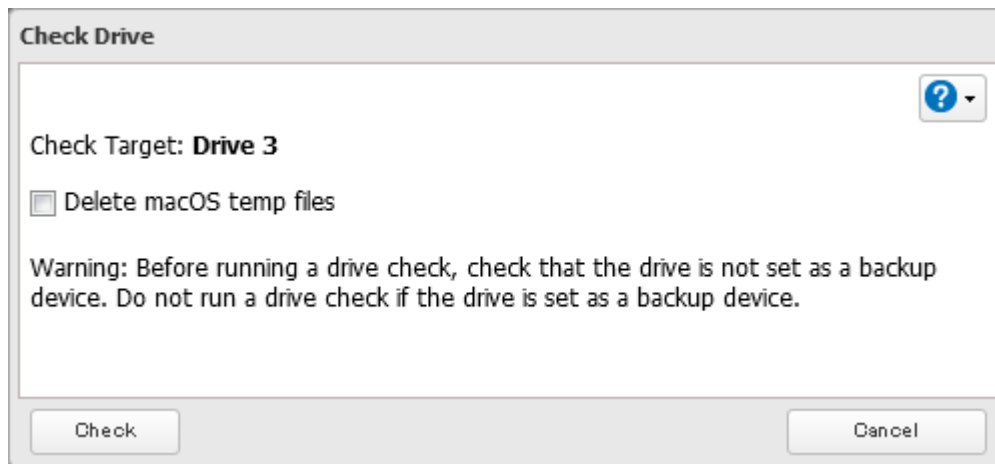

- 5** Either the I14 message for RAID arrays, the I21 message for drives, or the I27 message for USB drives will appear as a notification.

- 6** The process is complete once you close the confirmation window that appears.

S.M.A.R.T.

S.M.A.R.T. (Self-Monitoring, Analysis, and Reporting Technology) monitors internal drives to detect and report various indicators of reliability, in the hope of anticipating failures. If S.M.A.R.T. informs you of possible impending drive failure, you may choose to replace the drive to avoid potential outages and data loss. Follow the procedure below to check S.M.A.R.T. information for the TeraStation's internal drives.

Note: S.M.A.R.T. information is only available for internal drives.

Displaying S.M.A.R.T. Information

1 From Settings, click *Storage*.



2 Click the settings icon (⚙️) to the right of "Drives".

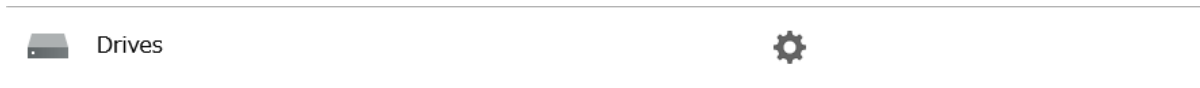

3 Select a drive to check and click *S.M.A.R.T.*

Drive/Array	Status	Encryption	Model Name	Total Capacity	Used Capacity	% Used
Array 1	Normal	—		3693.3 GB	16.2 GB	
Drive 1	Array 1 / Normal	—	HGST HUS726T4TAL	3693.5 GB		
Drive 2	Array 1 / Normal	—	HGST HUS726T4TAL	3693.5 GB		
Drive 3	Normal	—	HGST HUS726T4TAL	3693.3 GB	2 GB	
Drive 4	Normal	—	HGST HUS726T4TAL	3693.3 GB	2 GB	
Drive 5	Normal	—	HGST HUS726T4TAL	3693.3 GB	2 GB	
Drive 6	Normal	—	HGST HUS726T4TAL	3693.3 GB	2 GB	
Drive 7	Normal	—	HGST HUS726T4TAL	3693.3 GB	2 GB	
Drive 8	Normal	—	HGST HUS726T4TAL	3693.3 GB	2 GB	
Drive 9	Normal	—	HGST HUS726T4TAL	3693.3 GB	2 GB	
Drive 10	Normal	—	HGST HUS726T4TAL	3693.3 GB	2 GB	
Drive 11	Normal	—	HGST HUS726T4TAL	3693.3 GB	2 GB	
Drive 12	Normal	—	HGST HUS726T4TAL	3693.3 GB	2 GB	
SSD 1 for caching	Normal	—	P2TM2NMP5-2TbMiB47TB	1863 GB	0 GB	

- 4** The process is complete when the S.M.A.R.T. information for the drive is displayed. Different information may be displayed depending on the brand of drives on your TeraStation. Critical attributes are displayed in bold.

S.M.A.R.T.

Drive 3

Model: HGST HUS722T2TALA604 Serial Number: WCC6N1XR8CUZ
 Capacity: 2,000,398,934,016 bytes [2.00 TB] Firmware Version: RAGNWA09

Filter:

ID	Attribute	Status	Current Value	Worst Value	Threshold Value	Raw Value
1	Raw_Read_Error_Rate	OK	200	200	51	0
3	Spin_Up_Time	OK	182	182	21	3866
4	Start_Stop_Count	OK	100	100	0	402
5	Reallocated_Sector_Ct	OK	200	200	140	0
7	Seek_Error_Rate	OK	200	200	0	0
9	Power_On_Hours	OK	92	92	0	6251
10	Spin_Retry_Count	OK	100	100	0	0
11	Calibration_Retry_Count	OK	100	100	0	0
12	Power_Cycle_Count	OK	100	100	0	402
16	Gas_Gauge	OK	0	200	0	19699557343
183	Runtime_Bad_Block	OK	100	100	0	0

Close

Checking the Drive Condition

Attributes with the worst value that is equal to or less than the threshold value may be significant. If an attribute reports a failure, or has had one in the past, it will be displayed in the status column. In such a case, replacing that drive is recommended.

Formatting Drives

Notes:

- Under some circumstances, data deleted when a drive is formatted can be recovered. To ensure that data is “gone forever”, a format might not be sufficient. Refer to the [“Erasing Data on the TeraStation Completely”](#) section below for more information.
- After a drive is formatted, the “% Used” and “Used Capacity” in Settings will not be 0. This is because some drive space is used for the system area.

- 1** From Settings, click *Storage*.



2 Click the settings icon () to the right of “Drives” to format an internal drive or “USB Drives” to format an external drive.



3 Select the drive or array to format, then click *Format Drive*.

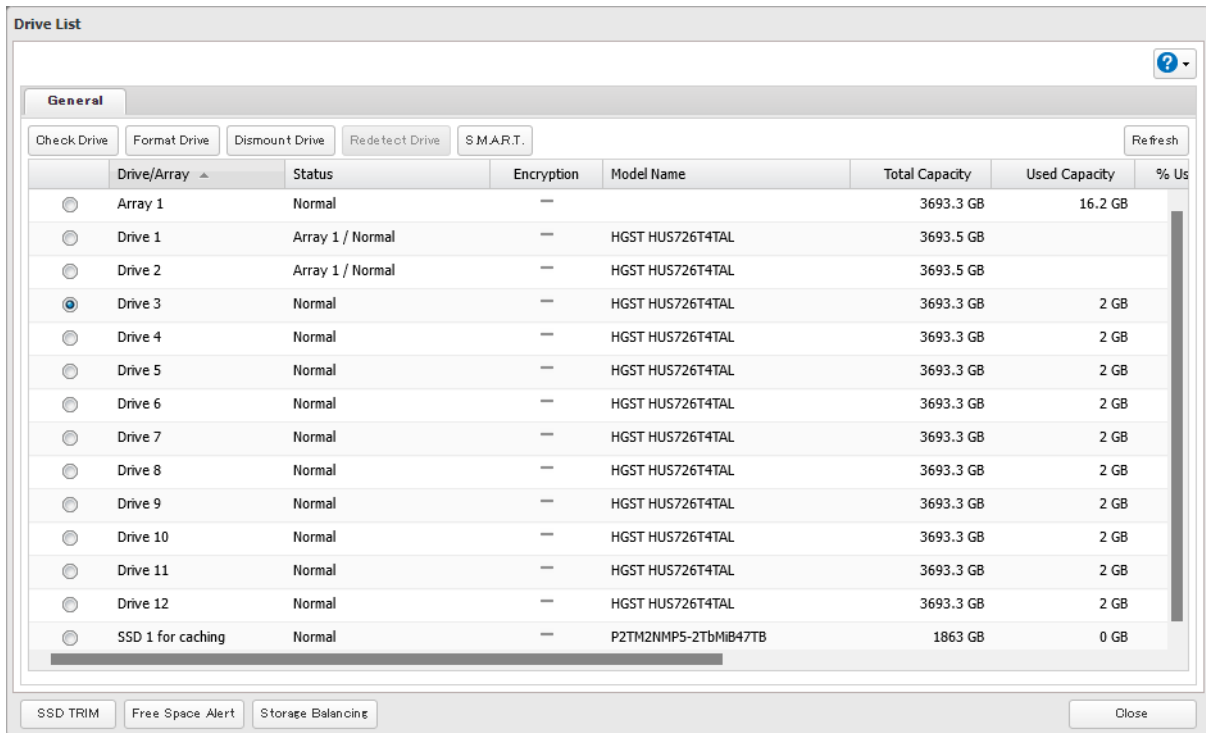

4 Select a file system, then click *Format*.

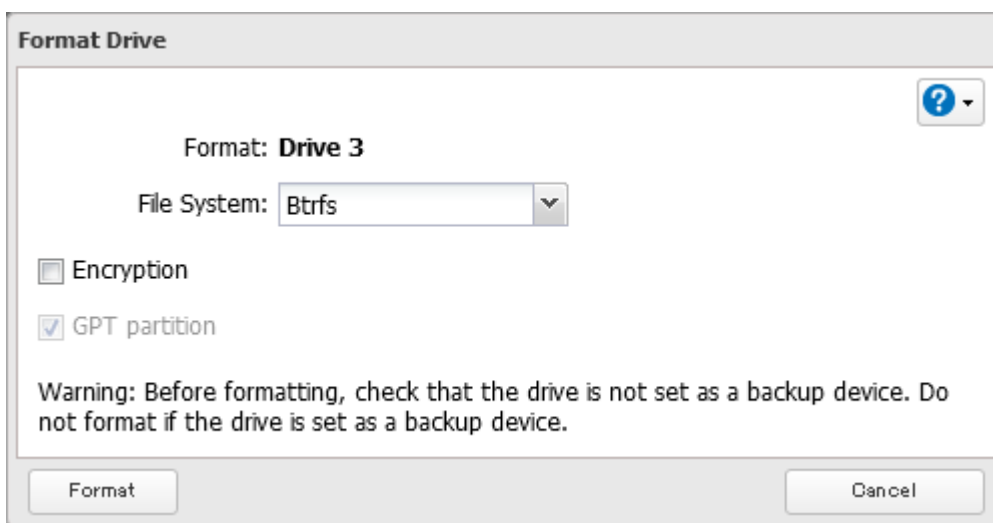

5 The “Confirm Operation” screen will open. Enter the confirmation number, then click *OK*.

6 Depending on the capacity and the formatted file system of your drive, the format may take several minutes or several hours to complete. Either the **I13** message for RAID arrays, the **I20** message for drives, or the **I28** message for USB drives will appear as a notification.

7 The process is complete once you close the confirmation window that appears.

Notes:

- Do not turn off or disconnect power to the TeraStation while formatting a drive.
- For drives that are 2.2 TB or larger, make sure that the “GPT partition” checkbox is selected.

Encrypting Drives

Internal drives (and arrays) can be encrypted with 256-bit AES during formatting. Encrypted drives and arrays are then readable only from that specific TeraStation. To decrypt a drive or array, clear the “Encryption” checkbox and format it again.

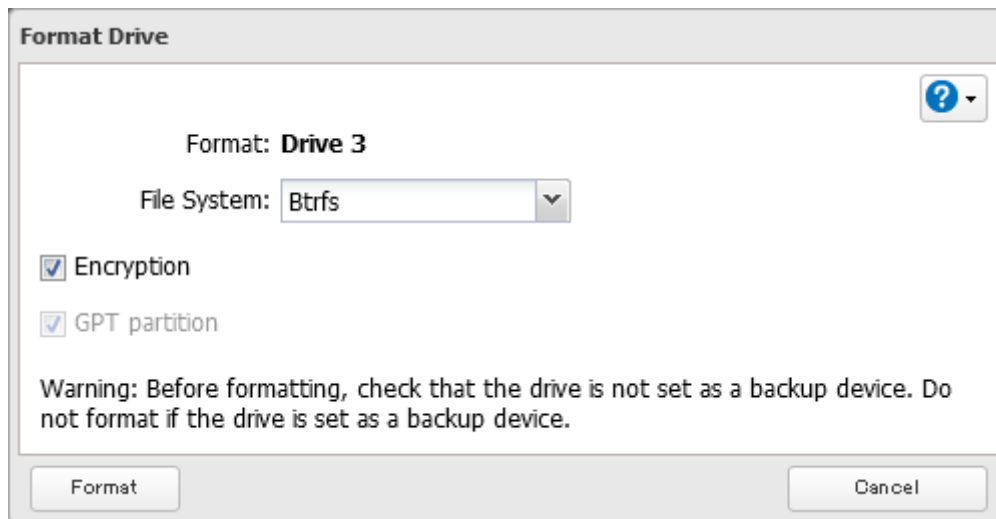

Erasing Data on the TeraStation Completely

The TeraStation offers two data erasure features: full drive formatting and Secure Erase. Select the data erasure feature that provides the appropriate level of security you prefer.

- **Full Format:** A full format will overwrite the drives with 0s. Typically, formatting drives on the TeraStation is sufficient to erase data, although data from formatted drives can still be recovered under some circumstances. This level of erasure is sufficient when you transfer, replace, or repair the TeraStation. Refer to the [“Performing a Full Format”](#) section below for the detailed procedure.
- **Secure Erase:** Secure Erase uses Secure Erase commands to fully erase data from the whole drive area. Secure Erase does a much more thorough job of erasing data, and is recommended for removing all data from a drive in a way that makes it nearly impossible to recover with current tools. This level of erasure is recommended if you are planning to dispose of the TeraStation. Refer to the [“Performing the Secure Erase Command”](#) section below for the detailed procedure.

Performing a Full Format

Follow the procedure below to perform a full format to the TeraStation. After performing a full format, make sure the TeraStation is transferred, replaced, or repaired accordingly.

The TeraStation will be in the following state after a full format is performed:

- All drives in JBOD
- An empty shared folder on each drive

- All settings returned to their default values
- All logs deleted

1 From Settings, click *Management*.

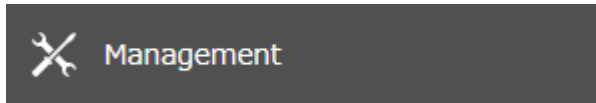

2 Click the settings icon () to the right of "Restore/Erase".

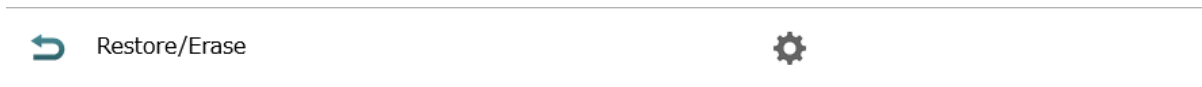

3 Click *Erase TeraStation*.

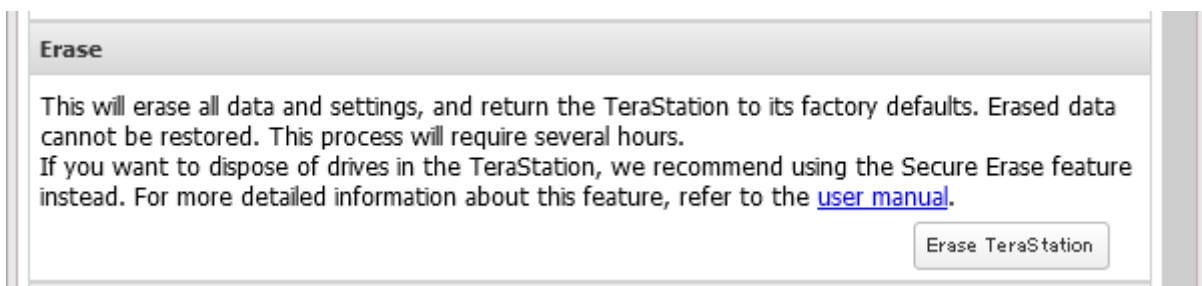

4 The "Confirm Operation" screen will open. Enter the confirmation number, then click *OK*.

5 The complete format process will begin. The process is complete when the TeraStation shuts down automatically. To power on the TeraStation, press the power button.

Note: If you remove a drive and then erase all data on the TeraStation, the E22 error along with the number of the removed drive will appear as a notification. You can still use the TeraStation.

Performing the Secure Erase Command

The Secure Erase feature runs the Secure Erase command native on a drive to eliminate its data using methods that meet the Purge category according to NIST 800-88 standards.

Follow the procedure below to perform the Secure Erase command on the TeraStation. After performing the Secure Erase command, dispose of the TeraStation and its drives accordingly.

The Secure Erase feature is intended to be permanently data destructive. Buffalo's product warranty does not cover data loss in the use of this or any other system application.

1 Press and hold down the power button for three seconds to turn off the TeraStation.

2 Turn the TeraStation back on while holding down the function button. You should hold down the function button for at least 10 seconds after pressing the power button.

3 When the power LED changes from blinking to glowing, release the function button and open Settings from NAS Navigator2.

4 Click *OK*.

5 Under the “Secure Erase” section, click *Start Secure Erase*.

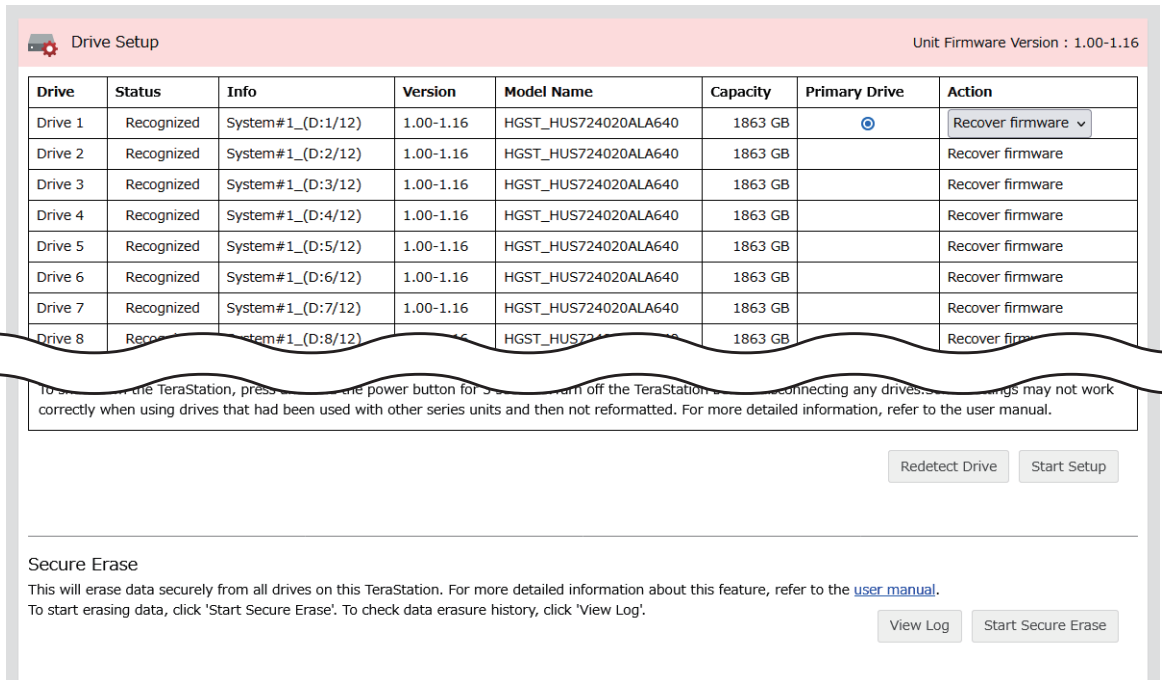

The screenshot shows the 'Drive Setup' interface with a table of drives and a 'Secure Erase' section below it.

Drive	Status	Info	Version	Model Name	Capacity	Primary Drive	Action
Drive 1	Recognized	System#1_(D:1/12)	1.00-1.16	HGST_HUS724020ALA640	1863 GB	<input checked="" type="radio"/>	Recover firmware ▾
Drive 2	Recognized	System#1_(D:2/12)	1.00-1.16	HGST_HUS724020ALA640	1863 GB	<input type="radio"/>	Recover firmware
Drive 3	Recognized	System#1_(D:3/12)	1.00-1.16	HGST_HUS724020ALA640	1863 GB	<input type="radio"/>	Recover firmware
Drive 4	Recognized	System#1_(D:4/12)	1.00-1.16	HGST_HUS724020ALA640	1863 GB	<input type="radio"/>	Recover firmware
Drive 5	Recognized	System#1_(D:5/12)	1.00-1.16	HGST_HUS724020ALA640	1863 GB	<input type="radio"/>	Recover firmware
Drive 6	Recognized	System#1_(D:6/12)	1.00-1.16	HGST_HUS724020ALA640	1863 GB	<input type="radio"/>	Recover firmware
Drive 7	Recognized	System#1_(D:7/12)	1.00-1.16	HGST_HUS724020ALA640	1863 GB	<input type="radio"/>	Recover firmware
Drive 8	Recognized	System#1_(D:8/12)	1.00-1.16	HGST_HUS724020ALA640	1863 GB	<input type="radio"/>	Recover firmware

Below the table, there are buttons for 'Redetect Drive' and 'Start Setup'. The 'Secure Erase' section contains the following text:

Secure Erase
 This will erase data securely from all drives on this TeraStation. For more detailed information about this feature, refer to the [user manual](#).
 To start erasing data, click 'Start Secure Erase'. To check data erasure history, click 'View Log'.

Buttons for 'View Log' and 'Start Secure Erase' are located at the bottom right of the Secure Erase section.

6 Read the message carefully and click *OK*.

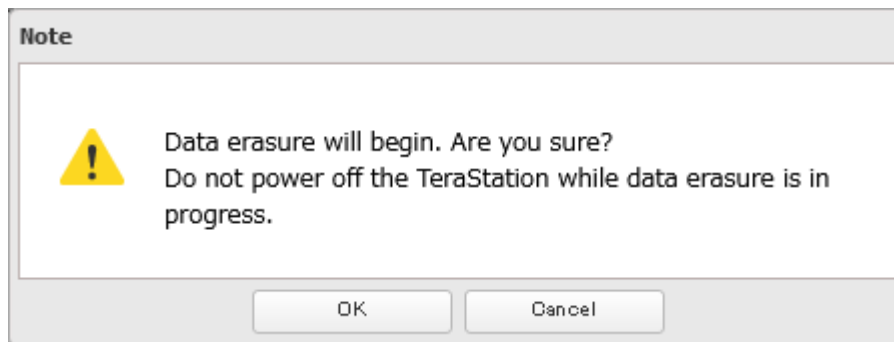

The screenshot shows a 'Note' dialog box with a warning icon (yellow triangle with an exclamation mark). The text inside the dialog box reads:

Data erasure will begin. Are you sure?
 Do not power off the TeraStation while data erasure is in progress.

At the bottom of the dialog box, there are two buttons: 'OK' and 'Cancel'.

7 The “Confirm Operation” screen will open. Enter the confirmation number, then click *OK*.

8 The Secure Erase process will begin. Wait until it's finished.

Note: The data erasure process will be run on multiple drives at the same time. The full process will take about 1.5 to 2.5 hours per terabyte, and the duration will vary depending on the model and status of the drives.

- 9** The process is complete once you close the following window. If you want to save the erasure log, click *Save Log*, then save the log file to the desired location.

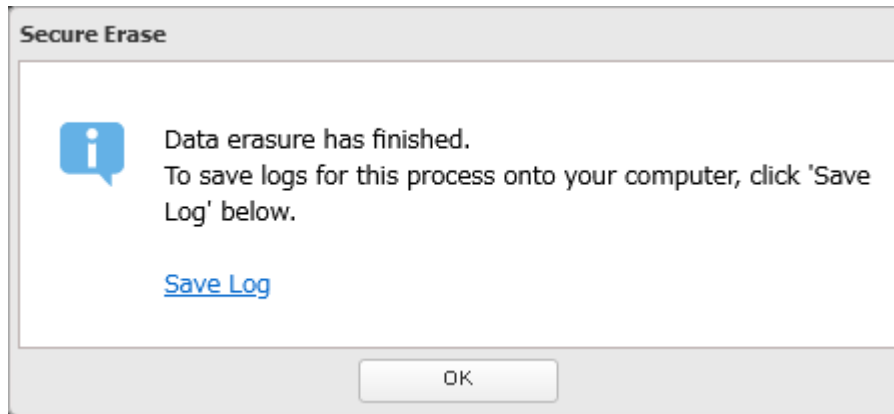

Notes:

- The Secure Erase feature will erase the system area where the firmware is installed. After running Secure Erase, the TeraStation will only be able to boot up in drive setup mode.
- If the TeraStation is powered off unexpectedly while the Secure Erase process is running such as due to a sudden power outage, follow the procedure below to recover it.
 - (1) If the TeraStation is currently on, turn the TeraStation off by pressing and holding down the power button for three seconds.
 - (2) Remove all drives from the TeraStation.
 - (3) Turn the TeraStation back on.
 - (4) When the power LED changes from blinking to glowing, reconnect the drives.
 - (5) Follow from step 3 in the [“Performing the Secure Erase Command”](#) section above to try the Secure Erase feature again.

Quotas

Limits for Shared Folders

You can set a quota for each shared folder, as well as set a quota alert where you will receive an email notification if the space used exceeds the configured quota threshold. To configure email notifications for the quota, refer to the [“Email Notification”](#) section in chapter 11.

Notes:

- When using quotas, disable the recycle bin or empty the trash folder often. The limited space includes the space used for trash.
- Quotas cannot be set for external drives connected to the TeraStation.

Follow this procedure to limit the shared folder space available for a user.

- 1** From Settings, click *File Sharing*.

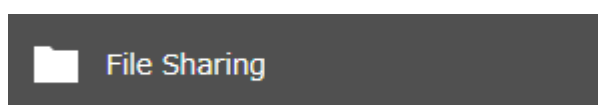

2 Click the settings icon () to the right of “Folder Setup”.



3 Click the shared folder that you want to give a quota.

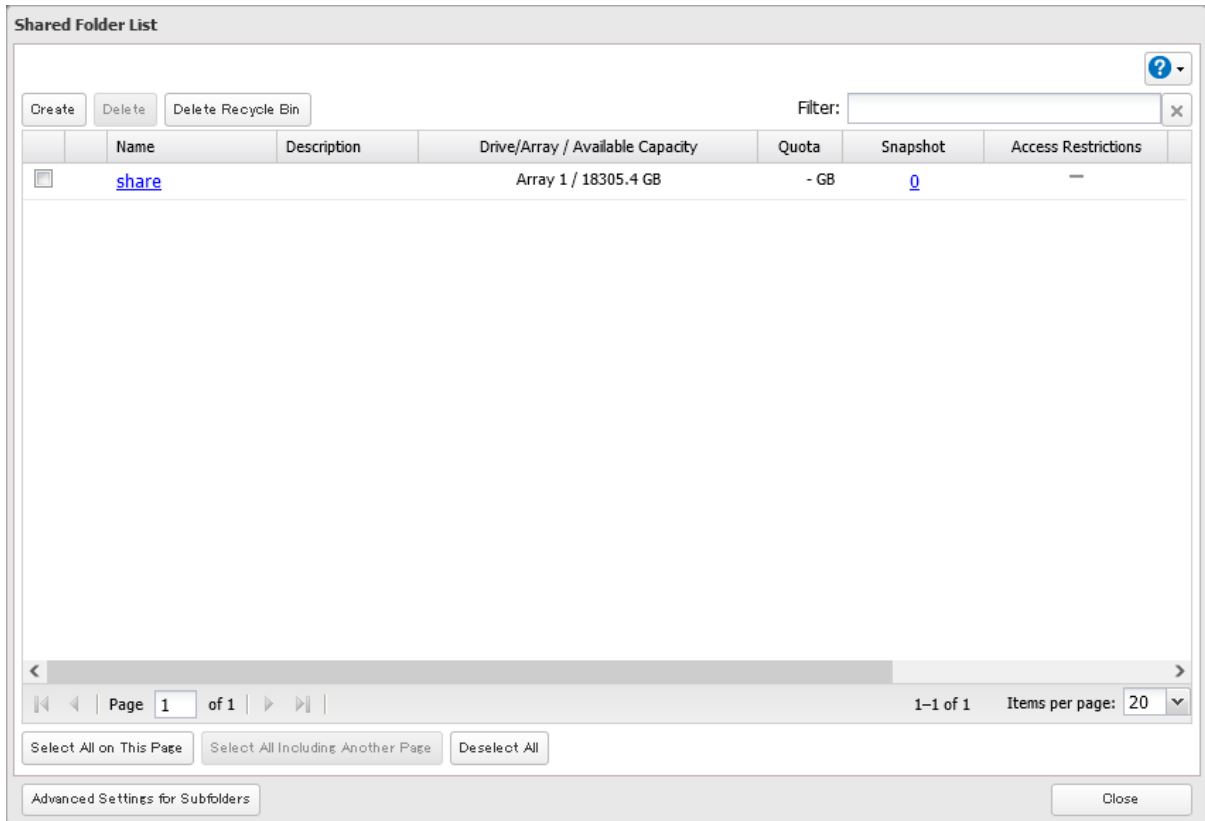

4 From the *Option 1* tab, enable “Quota” and choose the maximum amount of space the user will be allowed to use for “Quota Capacity”. You can also set the quota alert capacity, which triggers a notification email if the usage threshold is exceeded. Click *OK* when finished.

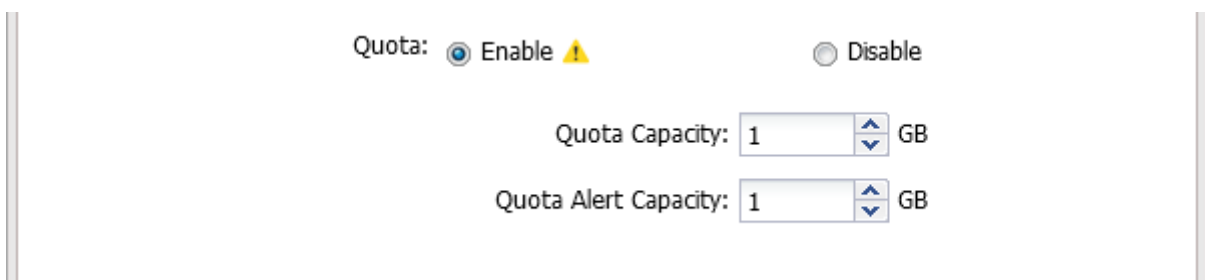

5 The process is complete once you close the confirmation window that appears.

Limits for LVM Volumes

If LVM is enabled, volumes can be created with maximum size limits.

Notes:

- When creating an LVM volume, all data in the area you specified for the LVM volume will be erased. Before changing any settings, back up any important data.

- Do not use any of the following words for the name of a volume as these words are reserved for internal use by the TeraStation: array x, authtest, disk x, global, homes, info, lost+found, lp, mediacartridge x, msdfs_root, mt-daapd, printers, ram, spool, usbdisk x. Any instances of "x" denote a number (for example: array1 or disk3)

1 From Settings, click *Storage*.



2 Click the settings icon () to the right of "LVM".

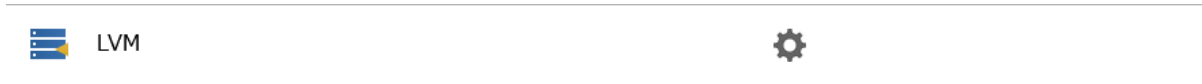

3 Select the drive or array where the volume will be located and click *Enable LVM*.

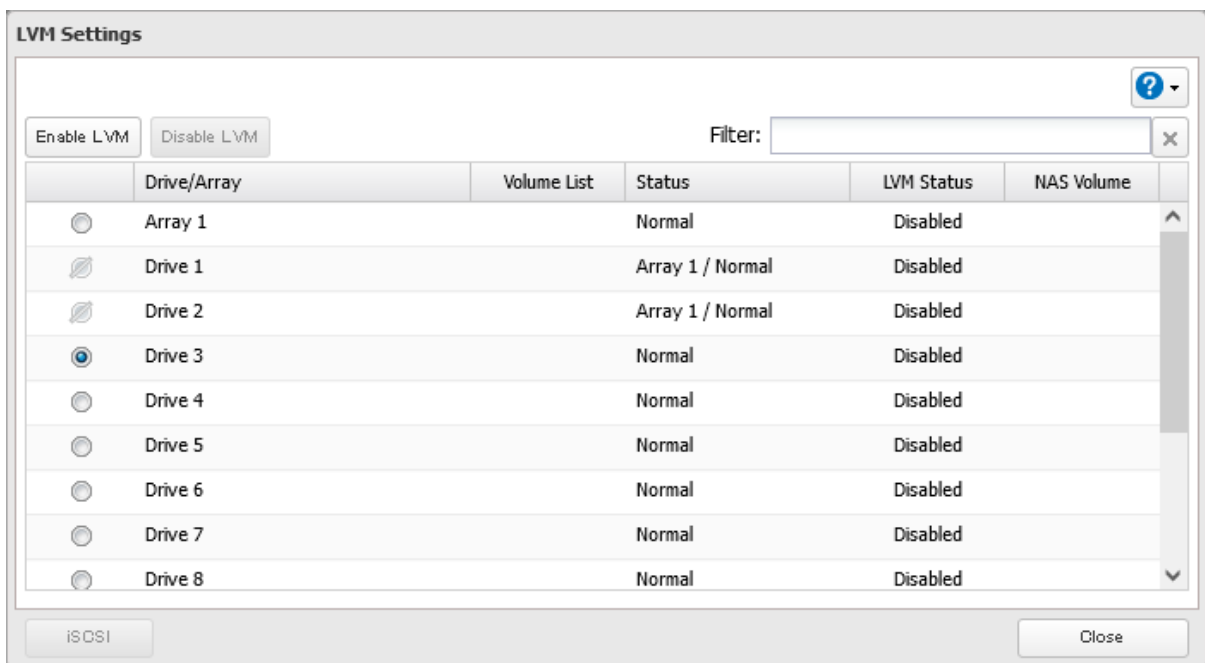

4 The "Confirm Operation" screen will open. Enter the confirmation number, then click *OK*.

5 Click *Edit* under “NAS Volume”.

LVM Settings

Enable LVM Disable LVM Filter:

	Drive/Array	Volume List	Status	LVM Status	NAS Volume
<input type="radio"/>	Array 1		Normal	Disabled	
<input type="radio"/>	Drive 1		Array 1 / Normal	Disabled	
<input type="radio"/>	Drive 2		Array 1 / Normal	Disabled	
<input checked="" type="radio"/>	Drive 3	<input type="button" value="Show"/>	LVM Enabled / Normal	Enabled	<input type="button" value="Edit"/>
<input type="radio"/>	Drive 4		Normal	Disabled	
<input type="radio"/>	Drive 5		Normal	Disabled	
<input type="radio"/>	Drive 6		Normal	Disabled	
<input type="radio"/>	Drive 7		Normal	Disabled	
<input type="radio"/>	Drive 8		Normal	Disabled	

iSCSI Close

6 Click *Create Volume*.

NAS Volume List: Drive 3

Create Volume Delete Volume Filter:

Volume Name	SSD Cache Status	Total Capacity	Used Capacity	% Used

Close

7 Configure the desired settings, then click *OK*.

8 The process is complete once you close the confirmation window that appears.

The usable capacity can now be limited by selecting the volume that you created for “Drive/Array” on the *Basic* tab when creating a shared folder.

Notes:

- If you click *Show* under “Volume List” on the LVM settings window, the volumes will be listed on the screen and you can see if these volumes are being used as iSCSI or NAS.
- If an LVM volume could not be mounted, try restarting the TeraStation. If an issue still exists, delete the LVM volume and recreate it. Deleting the LVM volume will erase all data on the volume.
- The available capacity will be less than the capacity you entered when creating an LVM volume due to some free space that will be allocated for system usage.

Using the TeraStation as an iSCSI Device

Introduction

iSCSI is a protocol for carrying SCSI commands over IP networks. Unlike traditional SAN protocols such as Fibre Channel, which requires special-purpose cabling, iSCSI can be run over long distances using existing network infrastructure. Normal Windows formatting such as NTFS is supported.

Differences Between NAS and iSCSI

With iSCSI, the TeraStation is connected to a single computer, such as a server. Other computers on the network access files on the TeraStation through the computer it’s connected to. The TeraStation can be used as a local drive from Windows Server. Features of Windows Server such as Active Directory can be used normally.

As a NAS, the TeraStation is a server, and computers (including other servers) on the network can access shared folders on it directly. A separate server is not required, and features such as backup are built-in.

Network Configuration

Use gigabit or faster network equipment with iSCSI. For best results, a dedicated network for iSCSI is recommended, separate from the regular network. By default, the IP address of the TeraStation is automatically assigned from a DHCP server. However, in this case, if you turn off and restart the TeraStation, the IP address may be changed and the volumes on the TeraStation may not be accessible. To avoid changing the IP address unexpectedly, using a static IP address for the TeraStation is recommended.

Connection Tool

The Microsoft iSCSI Software Initiator is already installed on your computer. You don't need to download and install it.

Creating an iSCSI Volume

To use the TeraStation as an iSCSI drive, create a volume first. Configure the TeraStation as described below.

Notes:

- If the volume settings are changed, all data on the volume will be erased. Before changing any settings, back up any important data.
- The TeraStation can have up to 255 volumes, but we recommend creating no more than 32. Exceeding this volume amount may cause irreparable damage to the unit.
- Do not use a name already in use as a shared folder name; do not use any of the following words for the name of a volume as these words are reserved for internal use by the TeraStation: array *x*, authtest, disk *x*, global, homes, info, lost+found, lp, mediacartridge *x*, msdfs_root, mt-daapd, printers, ram, spool, usbdisk *x*. Any instances of "x" denote a number (for example: array1 or disk3)
- There are two options for the "Backstore" setting to select the type of iSCSI volume. Refer to the differences below.

- **File I/O:** This type of volume can specify the volume capacity and multiple volumes can be created on one drive or RAID array. This also allows you to expand the volume capacity after the volume is created and data has been stored.

Snapshots can be created on the iSCSI volume. The volume can also be set as a backup folder. However, be careful in regards to the free space on the volume being used for snapshots. The actual free space will be smaller than the value displayed on the Properties window in Windows. Use the Dashboard in Settings to verify the actual free space.



- **Block I/O:** This type of volume will create an iSCSI volume for a whole drive or RAID array. However, if you enable LVM, you can create multiple volumes on the drive or the RAID array or expand the volume capacity later, just like a file I/O volume. It is recommended to enable LVM if you want to create multiple volumes on one drive or RAID array, or expand the volume later.

Block I/O volumes afford higher performance than file I/O volumes because there is less latency when bypassing the file system layer required for file I/O.

Be aware that block I/O volumes with LVM enabled cannot use snapshots. The volumes also cannot be used as the backup folders.

- 1 From Settings, click *Storage*.



- 2 Move the iSCSI switch () to the  position to enable iSCSI.



- 3 Click the settings icon () to the right of "iSCSI".



4 Click *Create Volume*.

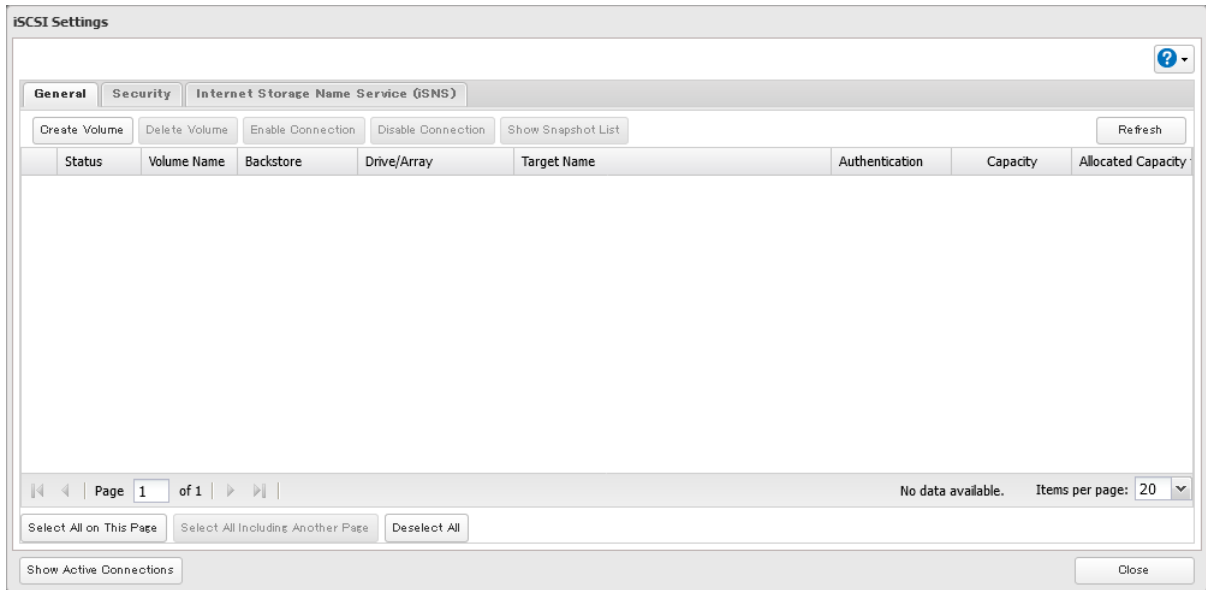

5 Configure the desired settings, then click *OK*.

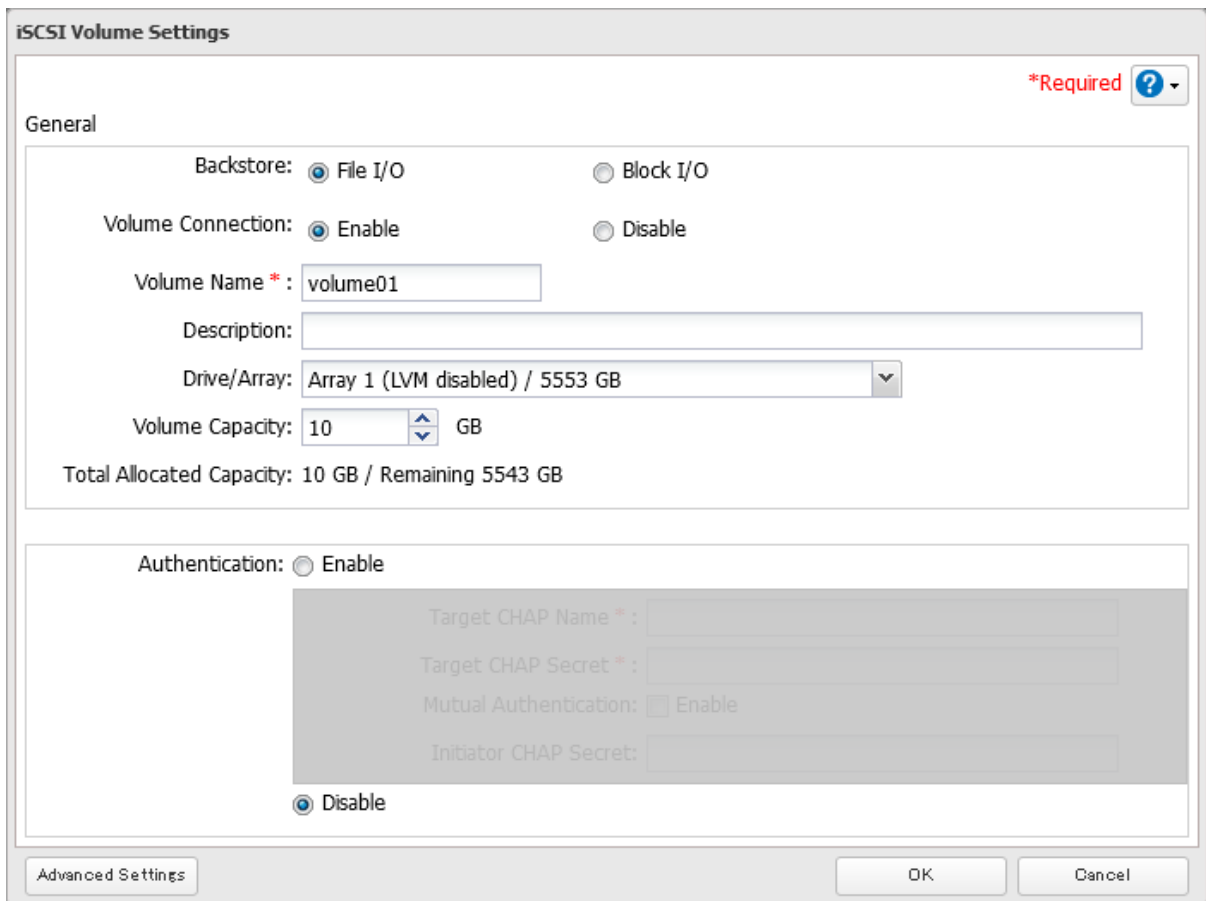

Notes:

- If creating file I/O volumes with LVM enabled, also specify the capacity for storing snapshots. If you don't want to set aside any capacity, set the "Allocated Capacity for Snapshots" to "0 GB".
- If you have selected "Block I/O", write cache (WCE) cannot be configured from the "Advanced Settings" page.
- If using both iSCSI volumes and shared folders on the same area, it is recommended to create the iSCSI volumes with LVM enabled.

6 Read the message carefully and click *OK*.

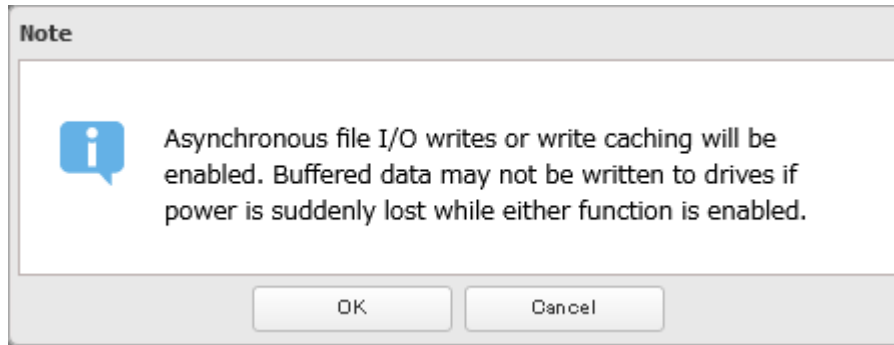

7 The process is complete once you close the confirmation window that appears.

Notes:

- Do not use the TeraStation's whole capacity for iSCSI volumes. Some features need free space in order to function. If there is no available free space, it may cause unexpected behavior.
- If you click *Disable Connection* for the selected volume in *Storage > iSCSI* in Settings, the selected iSCSI volume can no longer be accessed. If you click *Enable Connection*, the volume will become accessible from the iSCSI initiator software.

Connecting Volumes

To connect a volume, follow the procedure below.

Notes:

- When changing iSCSI volume settings, the iSCSI service will restart so iSCSI volumes will be unable to connect temporarily. It is recommended to disconnect the volume before changing the volume settings.
- Do not shut down the TeraStation while connecting to an iSCSI volume. It may cause unexpected data erasure. Make sure all connections are disconnected before shutdown.
- From firmware version 1.34 on, the iSCSI Extensions for RDMA (iSER) protocol will be enabled on iSCSI connections between a VMware server and iSCSI volumes on the TeraStation. An iSER-compatible network card will need to be installed on the TeraStation for iSER connections.

For detailed information on configuring iSCSI connections from a VMware server using the iSER protocol, refer to the VMware website.

1 From Windows, navigate to *Control Panel > System and Security > Administrative Tools > iSCSI Initiator*.

- Enter the IP address of the TeraStation into the “Target” field and click *Quick Connect*.

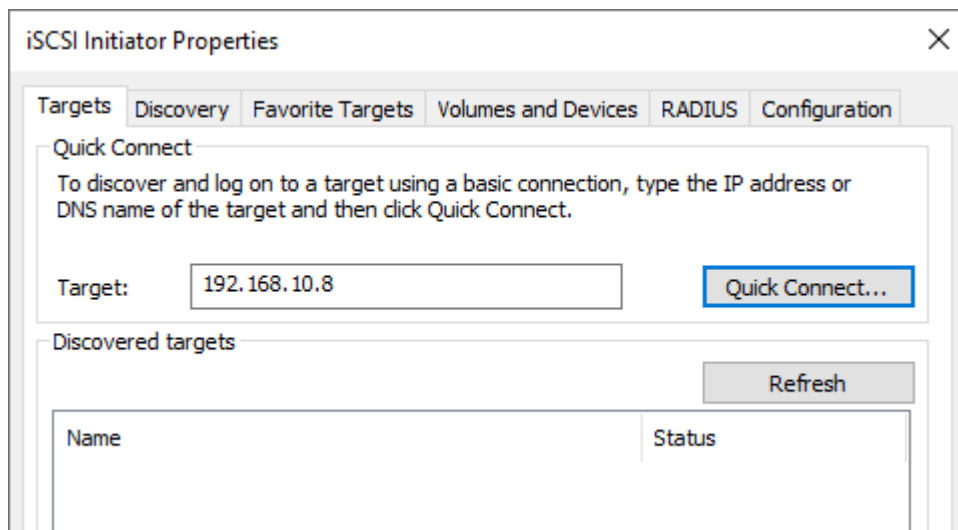

- Confirm if the connection is established and click *Done*.
- The process is complete when the status of the selected volume is displayed as “Connected” on the iSCSI initiator.
You can also check that the volume status is “Connected” in Settings by navigating to *Storage > iSCSI*.

Using with Multiple Computers

If the TeraStation is divided into multiple volumes (or drives), it can be used with multiple computers. However, it is not recommended to access a single volume or drive from multiple computers at the same time for security reasons. When using the TeraStation as an iSCSI device, it should only connect to a single initiator unless the computer running the initiator also has clustering enabled and configured on its operating system. To avoid using multiple initiators for access, enable mutual authentication.

Formatting Volumes

If using the connected volume for the first time, the volume should be formatted to be used as a local drive. Follow the procedure below for formatting.

- From Windows, navigate to *Control Panel > System and Security > Administrative Tools > Computer Management*.
- Click *Disk Management*.
When the “Initialize Disk” screen appears, click *OK* without changing any settings.
- Right-click the drive volume that shows the status “Unallocated” and click *New Simple Volume* from the displayed menu. Follow the screen to finish formatting.
- The process is complete when the drive is visible as an icon in Computer or This PC and can be used as a normal drive on the computer.

Disconnecting Volumes

To disconnect a volume, follow the procedure below.

- From Windows, navigate to *Control Panel > System and Security > Administrative Tools > iSCSI Initiator*.
The status of the connecting volume will be displayed as “Connected” under “Discovered targets”.
- Select a volume to disconnect and click *Disconnect*.

3 Click Yes.

4 The process is complete when the volume status is displayed as “Inactive” on the iSCSI initiator.

Configuring Access Restrictions

A CHAP name and secret can be configured for the entire iSCSI volume or each existing volume. Access restrictions can be configured so that entering a target CHAP name and secret is required for each connection.

The TeraStation can perform mutual authentication (two-way authentication). Dual passwords ensure that only authorized client computers can access the volume on the TeraStation.

Configuring for the Entire TeraStation

Follow the procedure below to enable access restrictions for the entire TeraStation.

1 From Settings, click *Storage*.



2 Click the settings icon () to the right of “iSCSI”.



3 Click the *Security* tab, then click *Edit*.

4 Enable “Authentication” and enter the target CHAP name and secret, then click *OK*.

 A dialog box titled "Security Settings" with a light grey border. At the top right, there is a red asterisk and the word "*Required" next to a blue question mark icon. The main content area has "Authentication:" followed by two radio buttons: "Enable" (which is selected) and "Disable". Below this is a white rectangular box containing four fields: "Target CHAP Name *:" with an empty text input, "Target CHAP Secret *:" with an empty text input, "Mutual Authentication:" followed by a checked checkbox and the word "Enable", and "Initiator CHAP Secret:" with an empty text input. At the bottom of the dialog box are two buttons: "OK" and "Cancel".

Note: To enable mutual authentication in addition to target CHAP name and secret authentication, select the “Enable” checkbox for “Mutual Authentication” and enter the initiator CHAP secret.

To search or connect the volume which has mutual authentication enabled from Microsoft iSCSI Initiator, initiator CHAP secret settings should be configured.

5 The process is complete once you close the confirmation window that appears.

Configuring for Individual Volumes

Follow the procedure below to configure access restrictions for individual volumes.

- 1 From Settings, click *Storage*.



- 2 Click the settings icon () to the right of "iSCSI".



- 3 Click the volume to enable access restrictions.

 A screenshot of the "iSCSI Settings" window. The window has a title bar and a help icon. Below the title bar are tabs for "General", "Security", and "Internet Storage Name Service (SNS)". Under the "General" tab, there are buttons for "Create Volume", "Delete Volume", "Enable Connection", "Disable Connection", "Show Snapshot List", and "Refresh". Below these buttons is a table with the following columns: Status, Volume Name, Backstore, Drive/Array, Target Name, Authentication, Capacity, and Allocated Capacity. The table contains one row with the following data: Status: Standing By; Volume Name: [volume01](#); Backstore: File I/O; Drive/Array: Array 1; Target Name: iqn.2004-08.jp.buffalo.cce1d5e74009.volume01; Authentication: -; Capacity: 10 GB; Allocated Capacity: 0 GB. At the bottom of the window, there is a pagination bar showing "Page 1 of 1", "1-1 of 1", and "Items per page: 20". There are also buttons for "Select All on This Page", "Select All Including Another Page", "Deselect All", "Show Active Connections", and "Close".

Status	Volume Name	Backstore	Drive/Array	Target Name	Authentication	Capacity	Allocated Capacity
<input type="checkbox"/> Standing By	volume01	File I/O	Array 1	iqn.2004-08.jp.buffalo.cce1d5e74009.volume01	-	10 GB	0 GB

- 4** Enable “Authentication” and enter the target CHAP name and secret, then click *OK*.

Note: To enable mutual authentication in addition to target CHAP secret authentication, select the “Enable” checkbox for “Mutual Authentication” and enter the initiator CHAP secret.

- 5** The process is complete once you close the confirmation window that appears.

Connecting Access-Restricted Volumes

Connecting if Volume Access Is Restricted

If access restrictions are configured for the entire iSCSI volume, that volume will not be detected by Microsoft iSCSI Initiator. To connect that volume, the target CHAP name and secret should be authenticated.

- 1** Open the Microsoft iSCSI Initiator.
- 2** Register the initiator CHAP secret to your computer first. If you didn’t enable mutual authentication, skip this step.
Click *CHAP* on the *Configuration* tab. Enter the configured initiator CHAP secret into the “Initiator CHAP secret” field and click *OK*.
- 3** From the *Discovery* tab, click *Discover Portal*.
- 4** Enter the TeraStation’s IP address into the “IP address or DNS name” field and click *Advanced*.
- 5** Select the “Enable CHAP log on” checkbox and enter the target CHAP name into the “Name” field and the target CHAP secret into the “Target secret” field.
If mutual authentication is enabled, select the “Perform mutual authentication” checkbox.

- 6** Click *OK*, then click *OK* again.
- 7** The iSCSI volumes on the TeraStation will be listed under “Discovered targets” on the *Targets* tab. Select the desired volume to connect and click *Connect*.
- 8** The process is complete when the status of the selected volume is displayed as “Connected” on the iSCSI initiator.

Connecting if Volume Access Is Partially Restricted

- 1** Open the Microsoft iSCSI Initiator.
- 2** Register the initiator CHAP secret to your computer first. If you didn’t enable mutual authentication, skip this step.
Click *CHAP* on the *Configuration* tab. Enter the configured initiator CHAP secret into the “Initiator CHAP secret” field and click *OK*.
- 3** From the *Discovery* tab, click *Discover Portal*.
- 4** Enter the TeraStation’s IP address into the “IP address or DNS name” field and click *OK*.
- 5** The iSCSI volumes on the TeraStation will be listed under “Discovered targets” on the *Targets* tab. Select the desired volume to connect and click *Connect*.
- 6** Click *Advanced*.
- 7** Select the “Enable CHAP log on” checkbox and enter the target CHAP name into the “Name” field and the target CHAP secret into the “Target secret” field.
If mutual authentication is enabled, select the “Perform mutual authentication” checkbox.
- 8** Click *OK*, then click *OK* again.
- 9** The process is complete when the status of the selected volume is displayed as “Connected” on the iSCSI initiator.

Expanding Volume Capacity

The capacities of the existing volumes can be expanded after they are created.

Notes:

- Expanding the volume capacity may erase all data on the volume depending on the formatting type. Backing up the data before expanding the volume capacity is recommended.
- To expand its capacity, the volume should be a file I/O volume; if expanding the capacity of a block I/O volume, it needs to have been created on a drive or array that has LVM enabled.

- 1** From Settings, click *Storage*.



2 Click the settings icon () to the right of “iSCSI”.



3 Select the volume to expand.

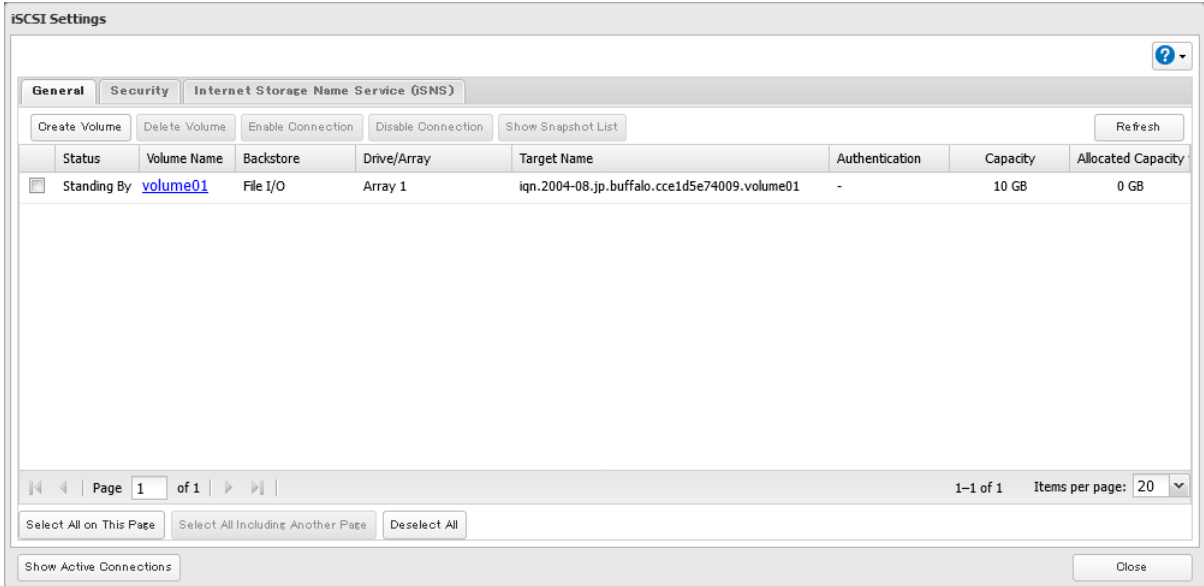

4 Enter the desired volume capacity to add and click OK.

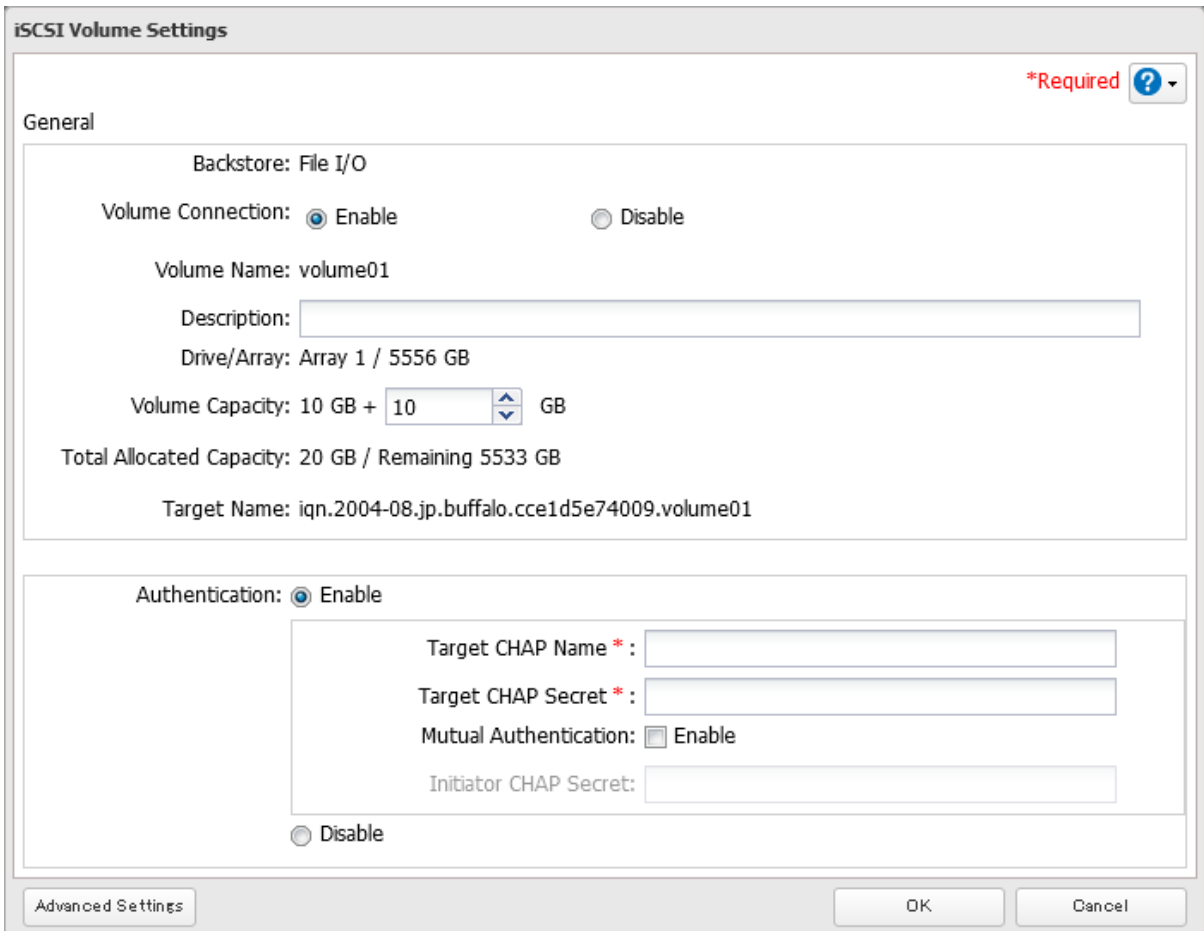

5 The process is complete once you close the confirmation window that appears.

Deleting Volumes

To delete an existing volume, follow the procedure below.

Note: Deleting a volume will erase all data on the volume. Back up the data before deleting the volume.

1 From Settings, click *Storage*.



2 Click the settings icon (⚙️) to the right of "iSCSI".



3 Select the volume to delete and click *Delete Volume*.

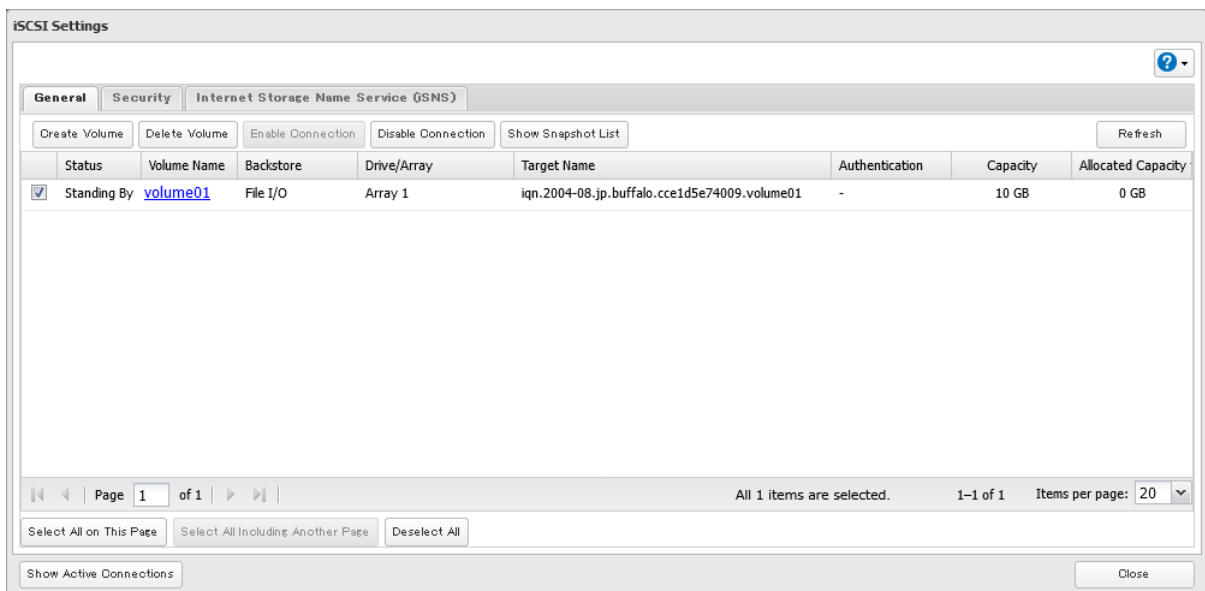

4 Confirm that the volume is correctly selected on the screen and click *OK*.

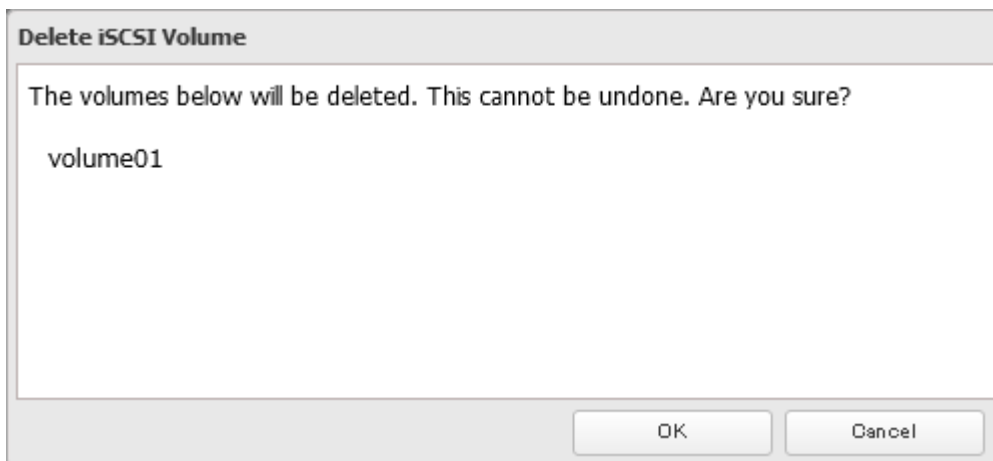

5 The "Confirm Operation" screen will open. Enter the confirmation number, then click *OK*.

6 The process is complete once you close the confirmation window that appears.

Enabling the iSNS Protocol

By enabling the iSNS protocol on the TeraStation, you can register an iSCSI target (volume) to an iSNS server and use it to manage the registered targets. To enable the iSNS protocol, follow the procedure below.

1 From Settings, click *Storage*.



2 Click the settings icon () to the right of "iSCSI".



3 Click the *Internet Storage Name Service (iSNS)* tab, then click *Edit*.

4 Enable "iSNS" and enter the IP address or hostname of the iSNS server, then click *OK*.

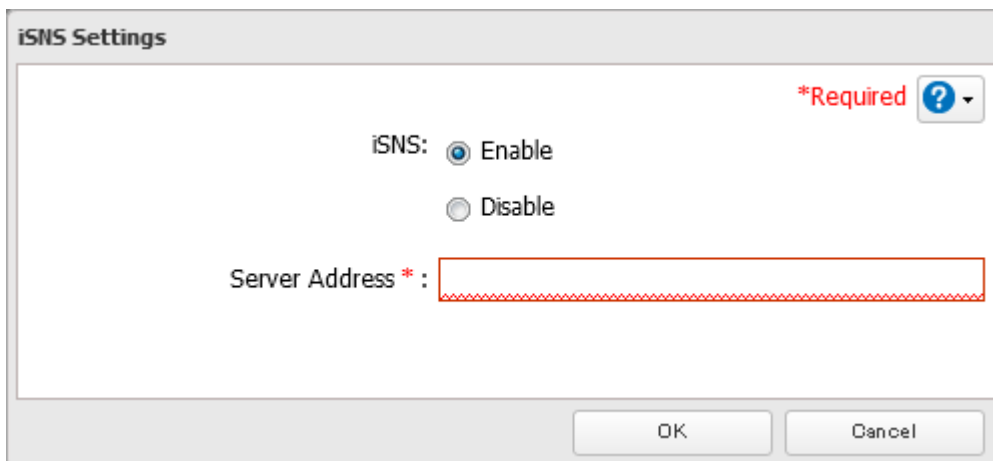

5 The process is complete once you close the confirmation window that appears.

Advanced iSCSI Volume Settings

You can configure the following advanced parameters for each iSCSI volume.

Advanced Parameter	Description
HeaderDigest	Controls the HeaderDigest usage by the iSCSI target portal group endpoint.
DataDigest	Controls the DataDigest usage by the iSCSI target portal group (TPG) endpoint.
MaxConnections	Controls the usage of Multiple Connections per Session (MC/S). Initiator and target negotiate the maximum number of connections requested and/or acceptable.
InitialR2T	Turns the default use of R2T (Ready to Transfer) on or off for unidirectional and the output part of bidirectional commands.
ImmediateData	Indicates whether the initiator and target have agreed to support immediate data on this session.
MaxRecvDataSegmentLength	Maximum data segment length in bytes the initiator and target can receive in an iSCSI Protocol Data Unit (PDU).

Advanced Parameter	Description
MaxXmitDataSegmentLength	Maximum data segment length in bytes that can be sent.
MaxBurstLength	Maximum iSCSI data payload in a Data-In or a solicited Data-Out iSCSI sequence, in bytes.
FirstBurstLength	Maximum amount in bytes of unsolicited data an iSCSI initiator can send to the target during the execution of a single SCSI command.
MaxOutstandingR2T	The R2T PDUs that can be in transition before an acknowledge PDU is received.
QueuedCommands	Maximum number of commands queued to any session of this target.
File I/O Write Sync	Synchronous file I/O provides reliability but slower performance. Asynchronous writes are faster, but buffered data will be lost if a power outage occurs.
Write Cache (WCE)	Increases performance. This cannot be used when block I/O is selected.
LUN	Number used to identify a local unit.

Increasing File Access Speeds Using SSD Caching

SSD caching will increase the read and write speeds for files.

Notes:

- To use SSD caching, an SSD card (sold separately) should be installed. Refer to the [“Adding an Expansion Card”](#) section in chapter 2 and install the SSD card before continuing with the procedure below.
- The following operations will not be available for a drive or RAID array as part of an LVM volume that is being used to create an SSD cache:
Checking drives, formatting drives, dismantling drives, redetecting drives, changing RAID settings, configuring a hot spare, disabling LVM, expanding iSCSI and LVM volume capacity
- An SSD cache that has been created on an array cannot be assigned to a volume on another array. You will need to delete the current SSD cache and create a new one for another array.

Creating an SSD Cache

To create an SSD cache, follow the procedure below.

1 Create an LVM volume first by referring to the [“Limits for LVM Volumes”](#) section above.

2 From Settings, click *Storage*.



3 Click the settings icon () to the right of “SSD Caching”.



4 Select the volume to create the SSD cache and click *Create*.

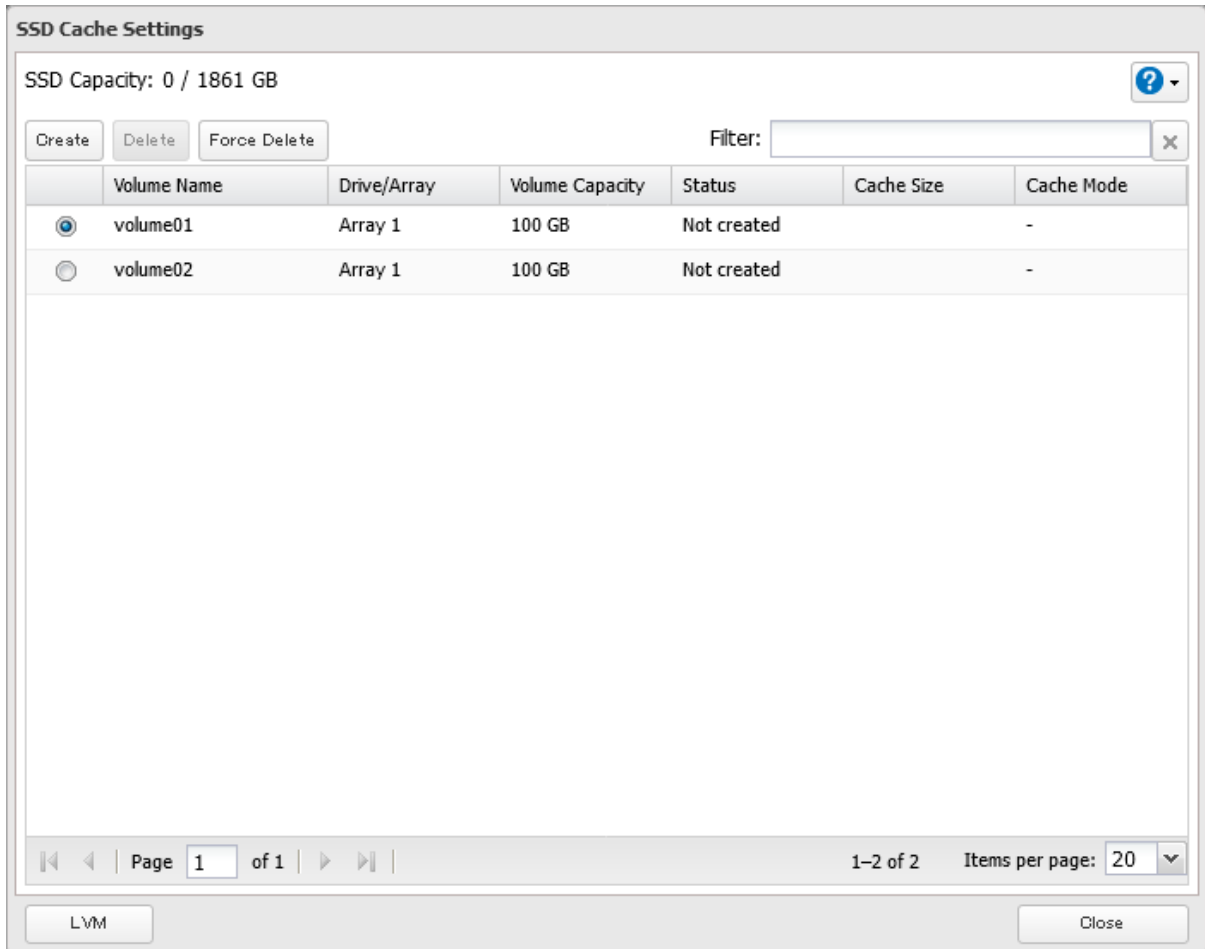

5 Enter the desired cache size to assign for the SSD cache and select the cache mode, then click *OK*.

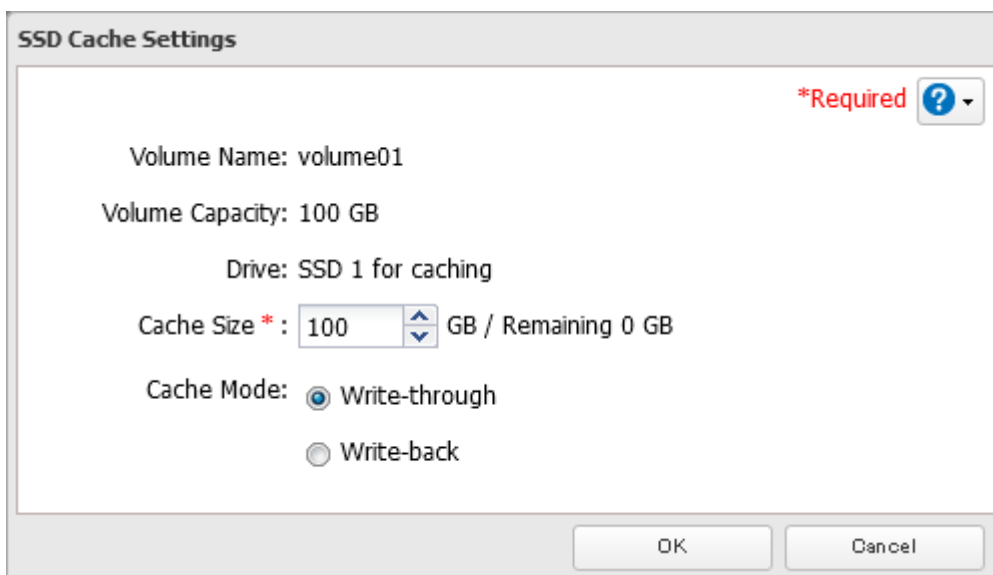

Note: The details of the cache modes are as below:

- **Write-through:** Data will be written to both the SSD for caching and the drive during write operations. This creates redundancy to increase data protection, and will have no effect on write speed.
- **Write-back:** Data will be first written to the SSD cache, and then is sent to the drive for storage. The write speed will be increased, but since data is only cached on the SSD, it will be lost if a cache failure occurs (such as due to a SSD drive error).

- 6 The “Confirm Operation” screen will open. Enter the confirmation number, then click *OK*.
- 7 The process is complete when the status of the LVM volume you created is displayed as “Created”.

SSD Cache Settings

SSD Capacity: 101 / 1861 GB ?

Create Delete Force Delete Filter:

	Volume Name	Drive/Array	Volume Capacity	Status	Cache Size	Cache Mode
<input checked="" type="radio"/>	volume01	Array 1	100 GB	Created	100 GB	Write-through

Deleting an SSD Cache

To delete an SSD cache, follow the procedure below.

- 1 From Settings, click *Storage*.



- 2 Click the settings icon (⚙️) to the right of “SSD Caching”.



- 3** Select the volume that includes the SSD cache to be deleted and click *Delete*.

SSD Cache Settings

SSD Capacity: 101 / 1861 GB

Create Delete Force Delete Filter:

	Volume Name	Drive/Array	Volume Capacity	Status	Cache Size	Cache Mode
<input checked="" type="radio"/>	volume01	Array 1	100 GB	Created	100 GB	Write-through
<input type="radio"/>	volume02	Array 1	100 GB	Not created	-	-

Page 1 of 1 1-2 of 2 Items per page: 20

LVM Close

- 4** The “Confirm Operation” screen will open. Enter the confirmation number, then click *OK*.

- 5** The deletion process will be performed in the background. The process is complete when the status of the LVM volume you deleted is displayed as “Not created”.

SSD Cache Settings

SSD Capacity: 0 / 1861 GB

Create Delete Force Delete Filter:

	Volume Name	Drive/Array	Volume Capacity	Status	Cache Size	Cache Mode
<input checked="" type="radio"/>	volume01	Array 1	100 GB	Not created	-	-

Note: If you cannot delete the SSD cache due to reasons such as the SSD card malfunctioning, try deleting it by force. However, since data stored on the SSD cache is not written to the drive, force deletion may cause the data to be corrupted.

Chapter 6 Backup

Snapshots

Overview

Snapshot is a function that creates a virtual copy of the data currently stored in a shared folder or iSCSI volume on the TeraStation. Once a snapshot has been created and saved, files and folders that are subsequently modified or deleted can be restored from the point at which the snapshot was created. The TeraStation allows you to not only create a snapshot manually, but also schedule automatic snapshots and auto-archive them to save TeraStation capacity.

Snapshots are saved to the read-only area, so they cannot be modified or deleted. Even if the network suffers a ransomware attack and files on the TeraStation are encrypted, you can revert files to a previously uninfected state from snapshots.

The created snapshots will be saved on the TeraStation. As with any file, if a drive malfunctions, all saved snapshots on that drive will be erased along with the data.

While snapshots can be used for short-term file backup and recovery, they should not be your sole data backup method.

Application for iSCSI Volume Snapshots

To create an iSCSI volume snapshot in the environment where the iSCSI volumes on the TeraStation are connected using a virtual machine, we recommend using the Buffalo-offered Windows Server application “Snapshot Agent for TeraStation”, available from the [Buffalo website](#).

The application can create both application-consistent and crash-consistent snapshots. An application-consistent snapshot contains all current data in memory and all I/O operations. Restoring from an application-consistent snapshot reverts the volume to the exact same state as when the snapshot was created. A crash-consistent snapshot, on the other hand, creates a snapshot of all the current files but not ongoing processes. Restoring from a crash-consistent snapshot only recovers saved data. Refer to the application help for detailed usage procedures.

Manually Creating a Snapshot

To create a snapshot for the shared folder or the iSCSI volume, follow the procedure below.

Notes:

- If an unexpected error occurs while taking a snapshot, you may have run out of available space. If this is the case, delete or move files to another location and try again.
- Up to 1,024 snapshots can be created for either a shared folder or an iSCSI volume. We recommend keeping no more than 65,536 snapshots total on the TeraStation. If you have created more than 65,536 snapshots, it may result in unexpected system behavior and slowdown.

For Shared Folders

- 1 From Settings, click *File Sharing*.

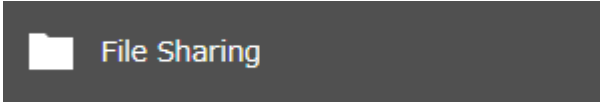
A screenshot of the Windows Settings application showing the 'File Sharing' option. The text 'File Sharing' is displayed in white on a dark grey background, with a white folder icon to its left.

2 Click the settings icon () to the right of "Folder Setup".



3 Click the number under "Snapshot" for the shared folder on the shared folder list.

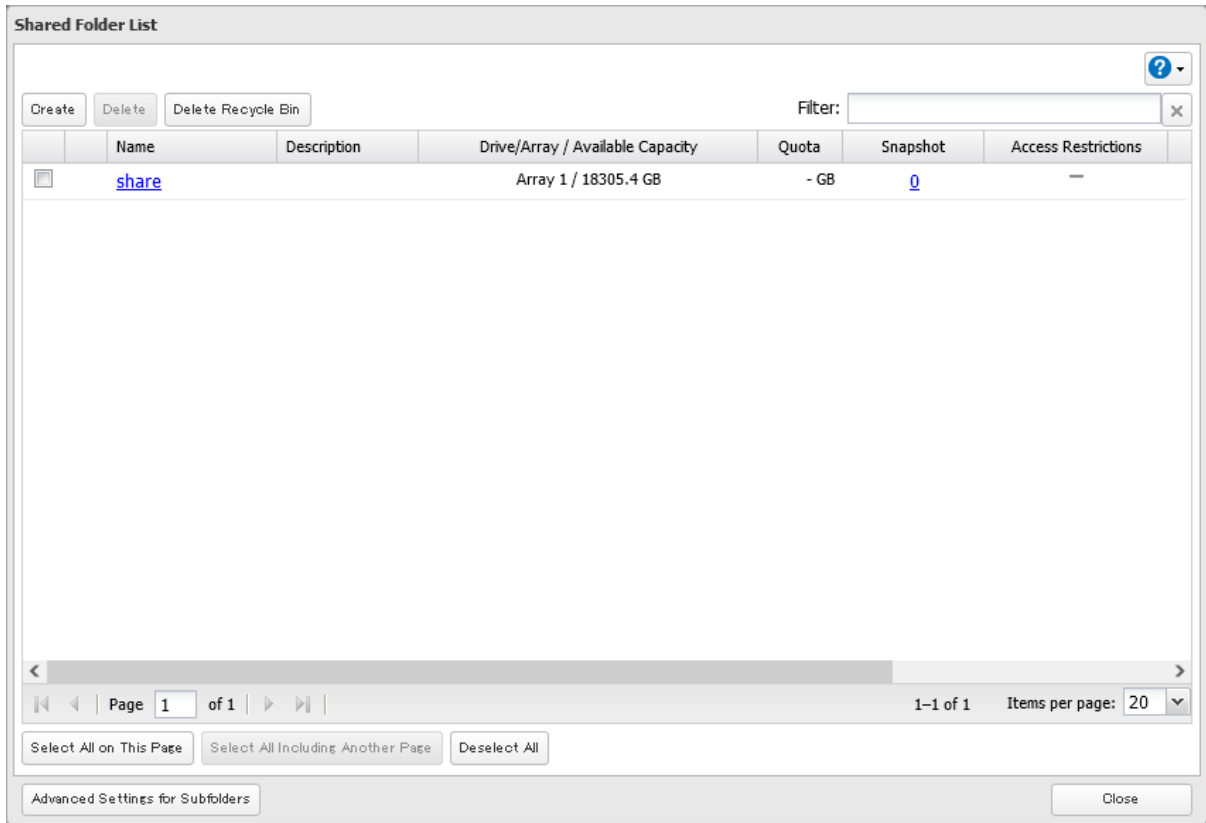

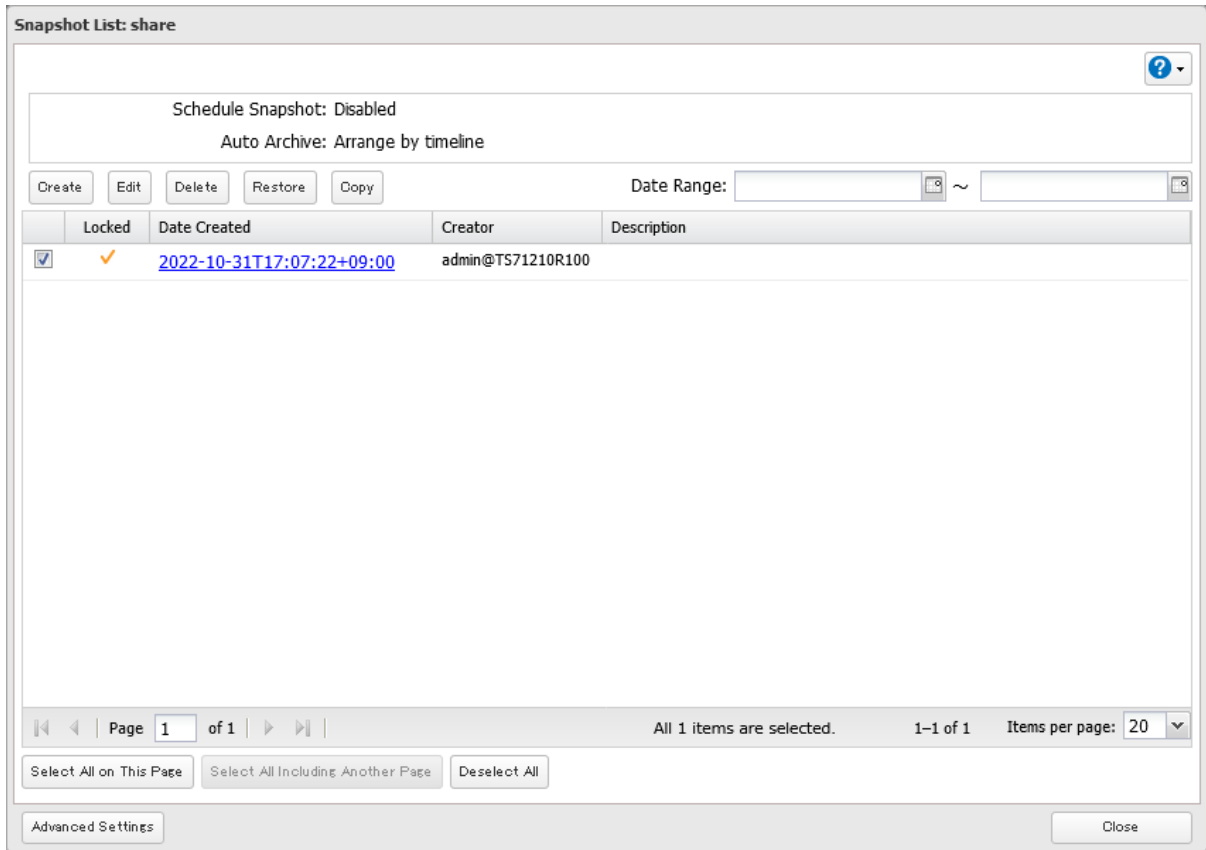
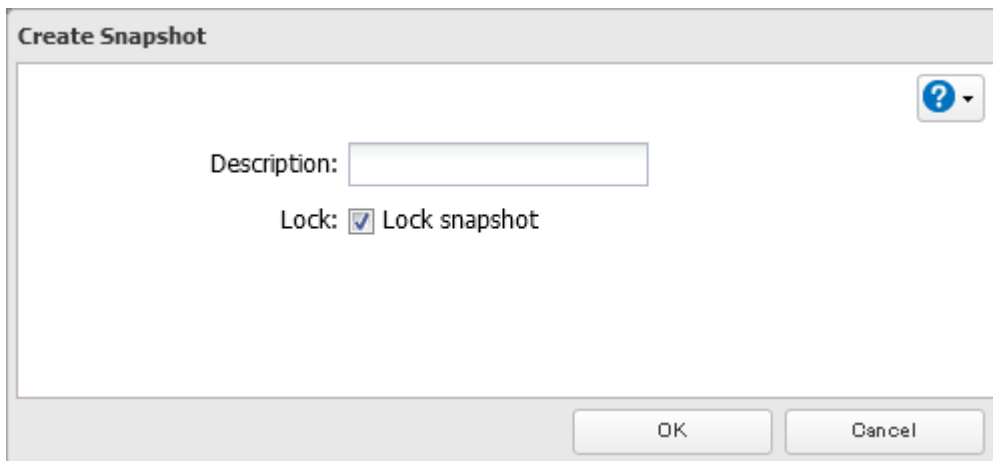
4 Click *Create*.**5** Select or clear the "Lock" checkbox to determine whether the created snapshot will be locked or unlocked and enter a short description, then click *OK*. A locked snapshot cannot be deleted due to auto-archiving.**6** The process is complete once you close the confirmation window that appears.**For iSCSI Volumes****1** From Settings, click *Storage*.

2 Click the settings icon () to the right of “iSCSI”.



3 Select the checkbox for the target iSCSI volume and click *Show Snapshot List*.

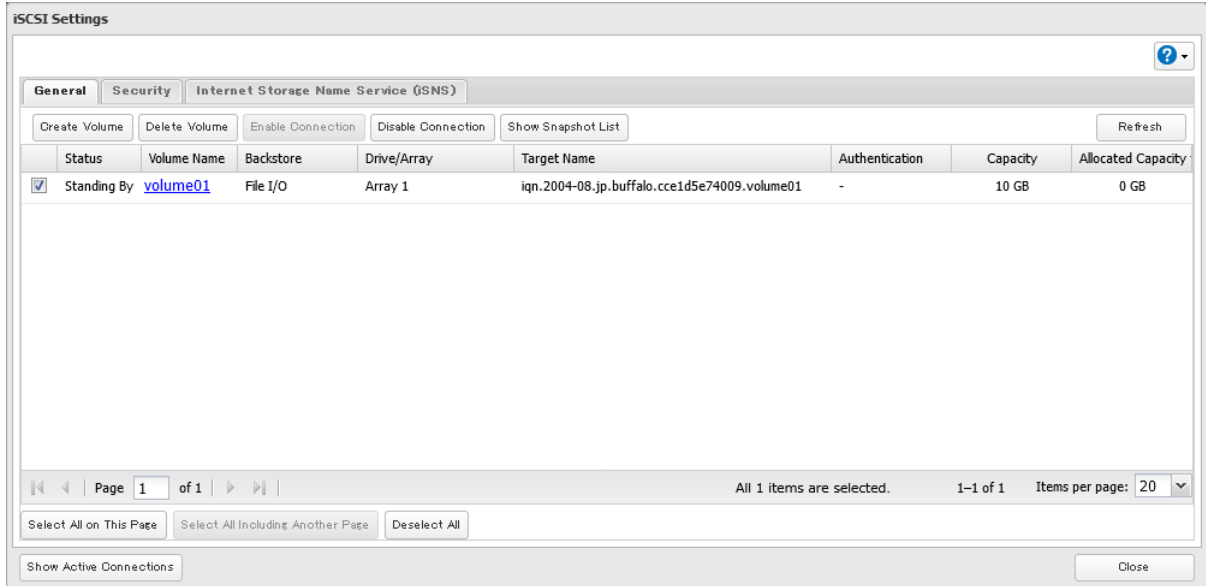

4 Click *Create*.

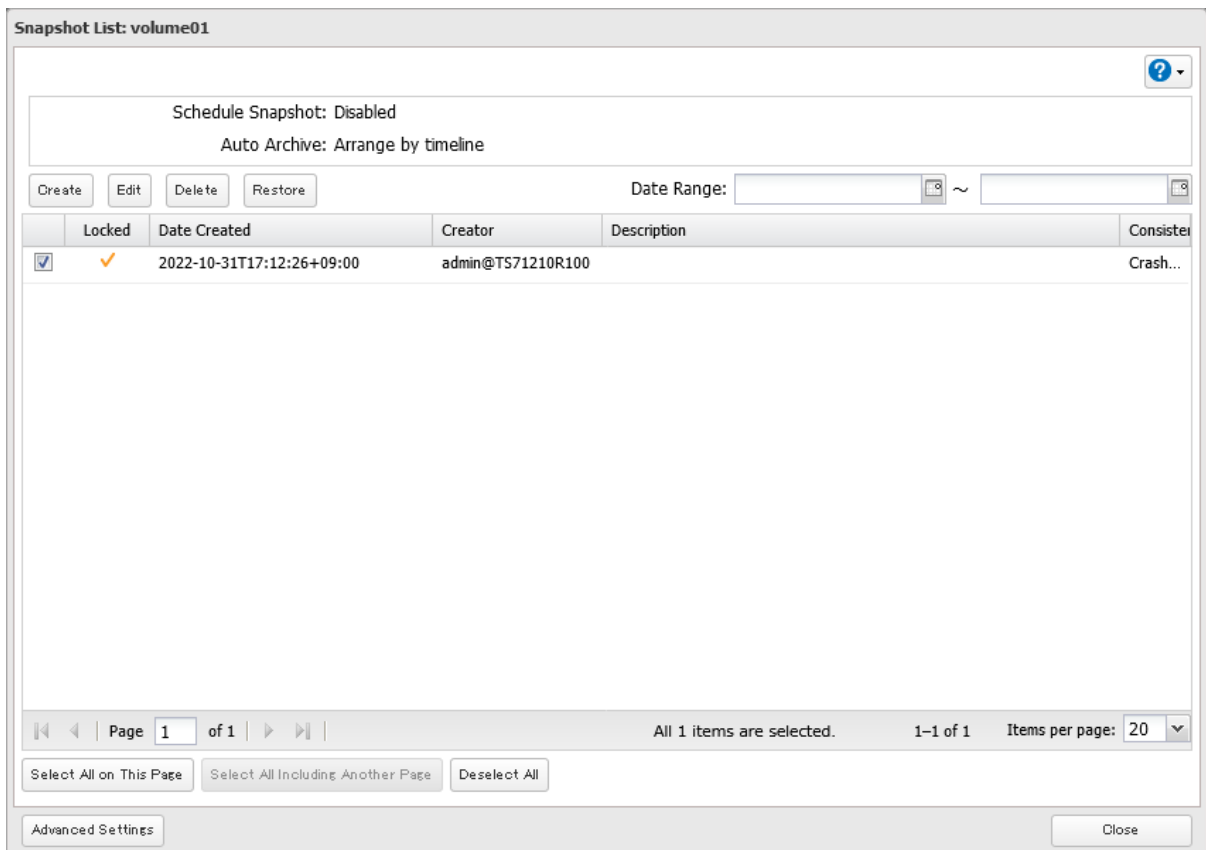

- 5** Select or clear the “Lock” checkbox to determine whether the created snapshot will be locked or unlocked and enter a short description, then click *OK*. A locked snapshot cannot be deleted due to auto-archiving.

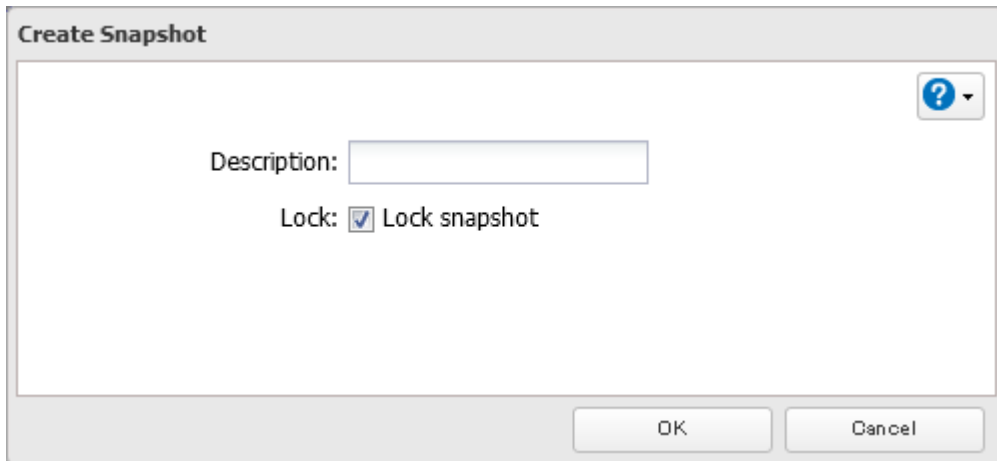

- 6** The process is complete once you close the confirmation window that appears.

Accessing the Snapshots via SMB

From a Windows computer, you can access snapshots using the “Restore previous versions” option.

- 1** From Settings, click *File Sharing*.

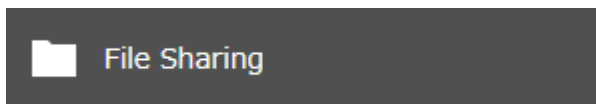

- 2** Click the settings icon () to the right of “Folder Setup”.



3 Click the shared folder to access snapshots from the computer.

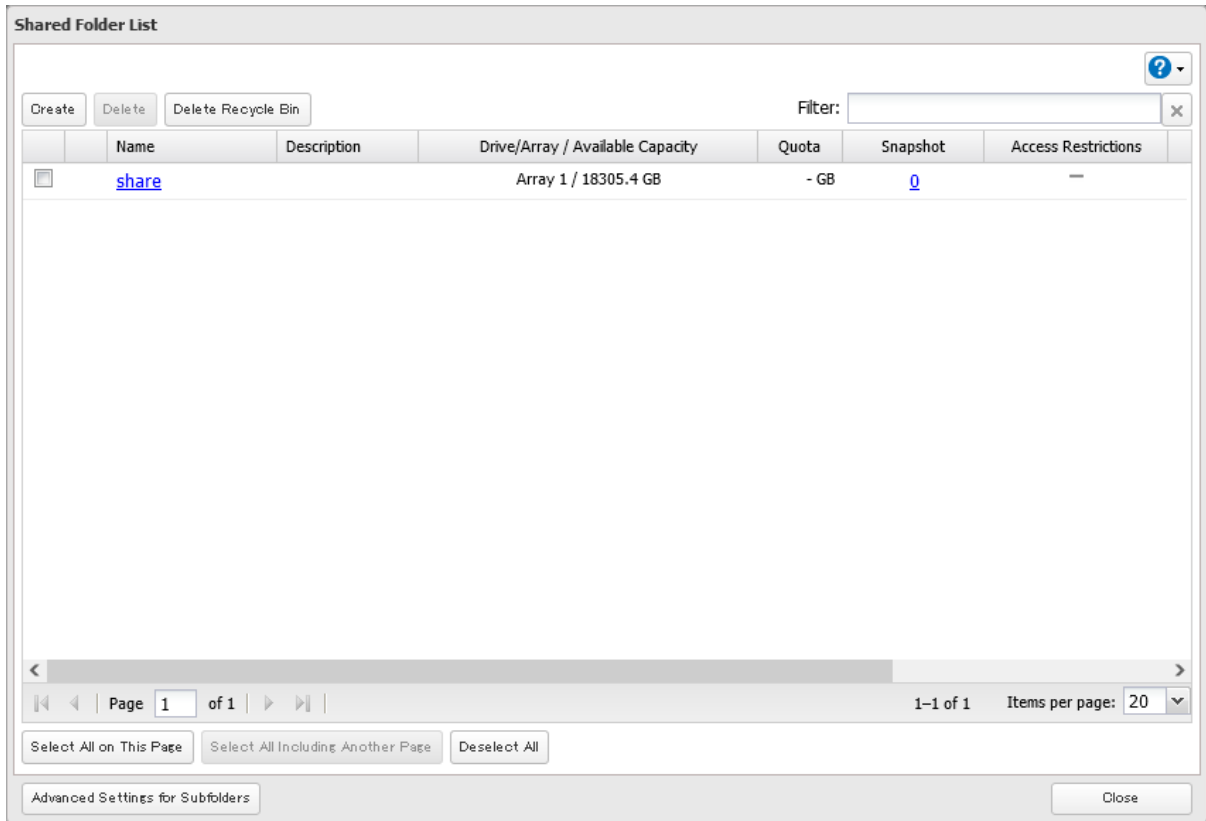

4 Click the *Option 2* tab and enable "Shadow Copy", then click *OK*.

Shadow Copy: Enable Disable

5 From the computer, access the TeraStation using File Explorer and right-click the shared folder to view snapshots.

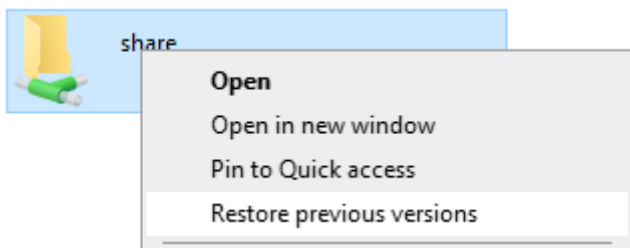

6 Click *Restore previous versions*.

- 7** The entire history of created snapshots will appear. Select the snapshot and the action to be taken for the snapshot.

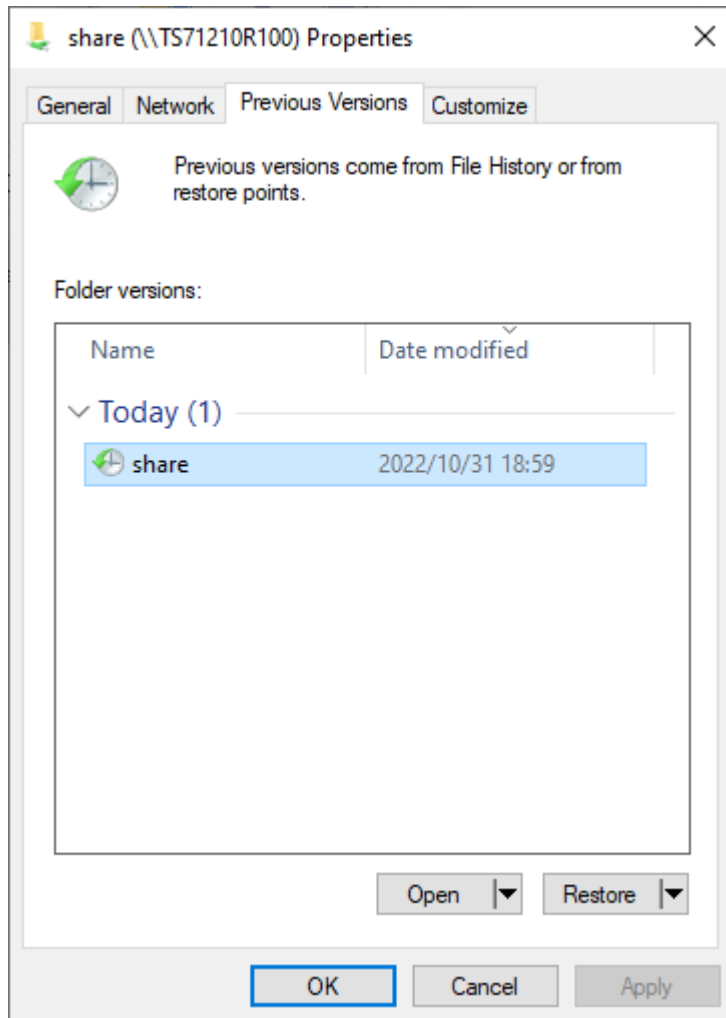

Restoring Snapshots

To restore the created snapshots to the shared folder or the iSCSI volume, follow the procedure below.

For Shared Folders

Note: When restoring snapshots, the file sharing service will restart so shared folders will become inaccessible temporarily.

- 1** From Settings, click *File Sharing*.

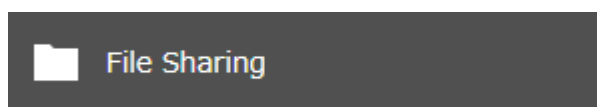

- 2** Click the settings icon (⚙️) to the right of "Folder Setup".

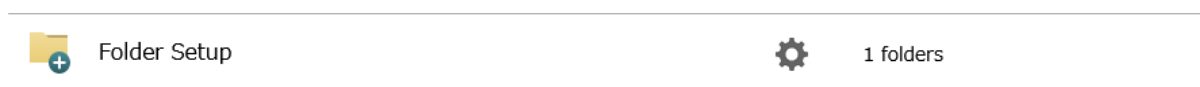

3 Click the number under “Snapshot” for the shared folder on the shared folder list.

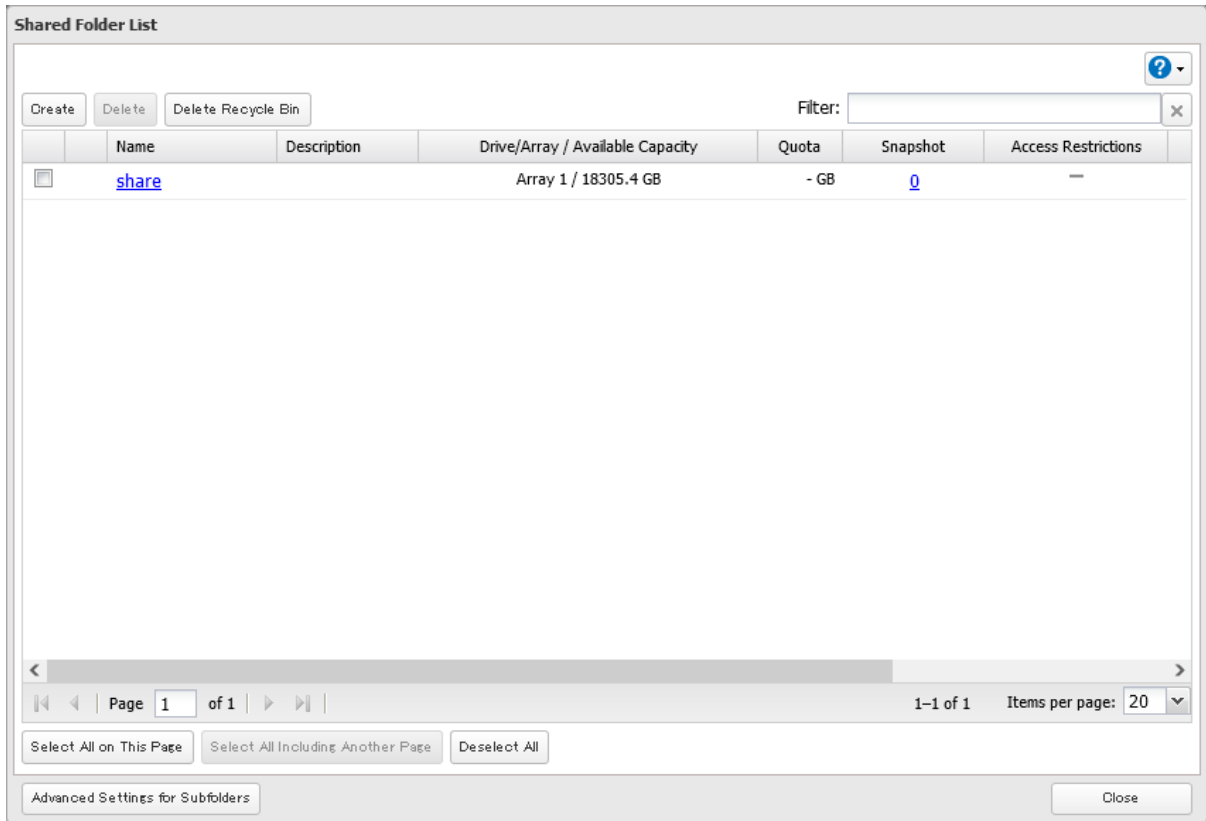

4 Select the checkbox for the target snapshot and then click *Restore*.

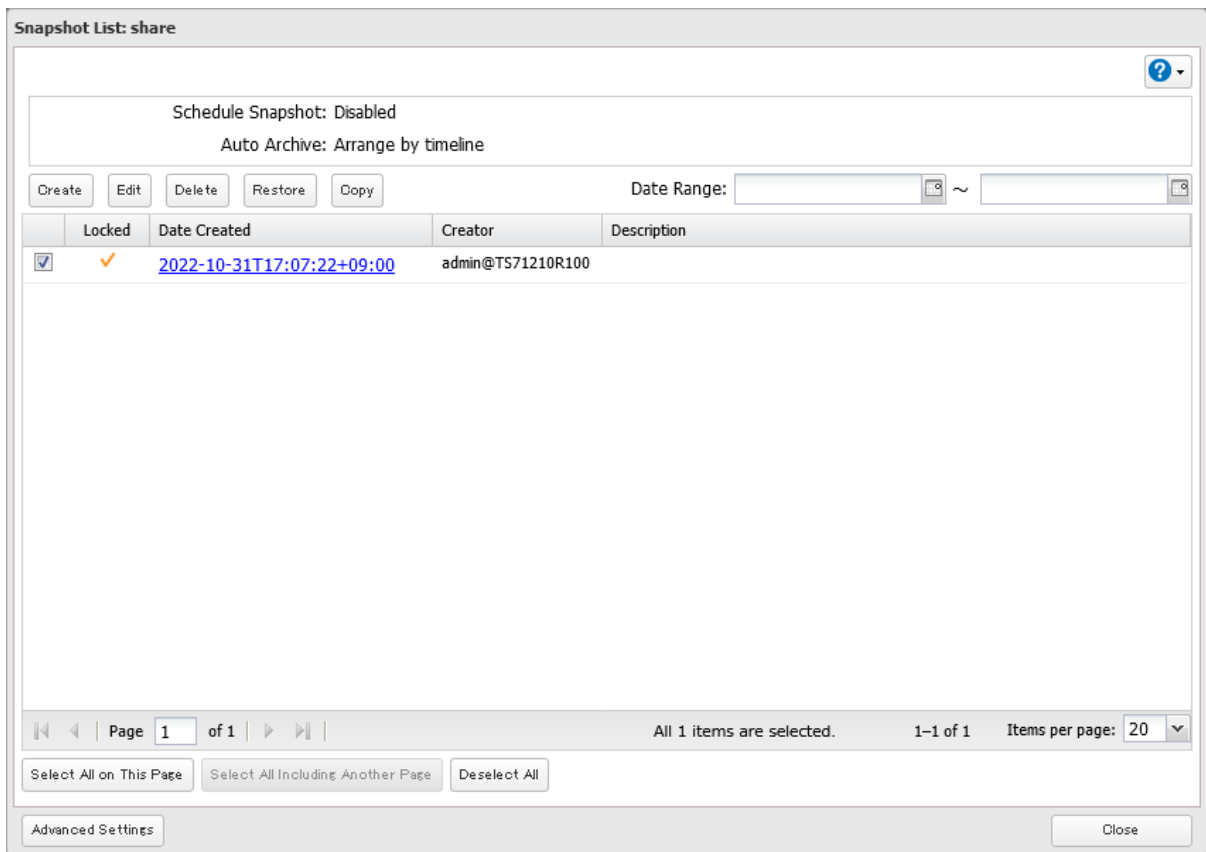

- 5** A new snapshot will be created before restoring the snapshot. Select or clear the “Lock” checkbox to determine whether the created snapshot will be locked or unlocked and enter a short description, then click *OK*. A locked snapshot cannot be deleted due to auto-archiving.

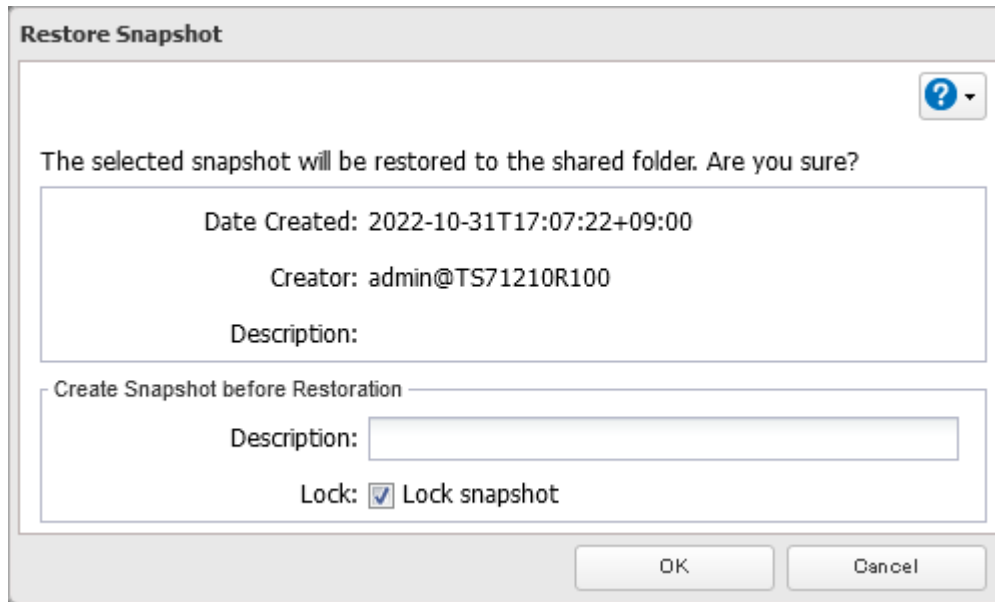

- 6** The process is complete once you close the confirmation window that appears.

For iSCSI Volumes

Note: When restoring snapshots, the iSCSI service will restart so iSCSI volumes will become unable to connect temporarily. If you have saved the virtual machine to the iSCSI volume, shut down the virtual machine before restoring.

- 1** From Settings, click *Storage*.



- 2** Click the settings icon (⚙️) to the right of “iSCSI”.



3 Select the checkbox for the target iSCSI volume and click *Show Snapshot List*.

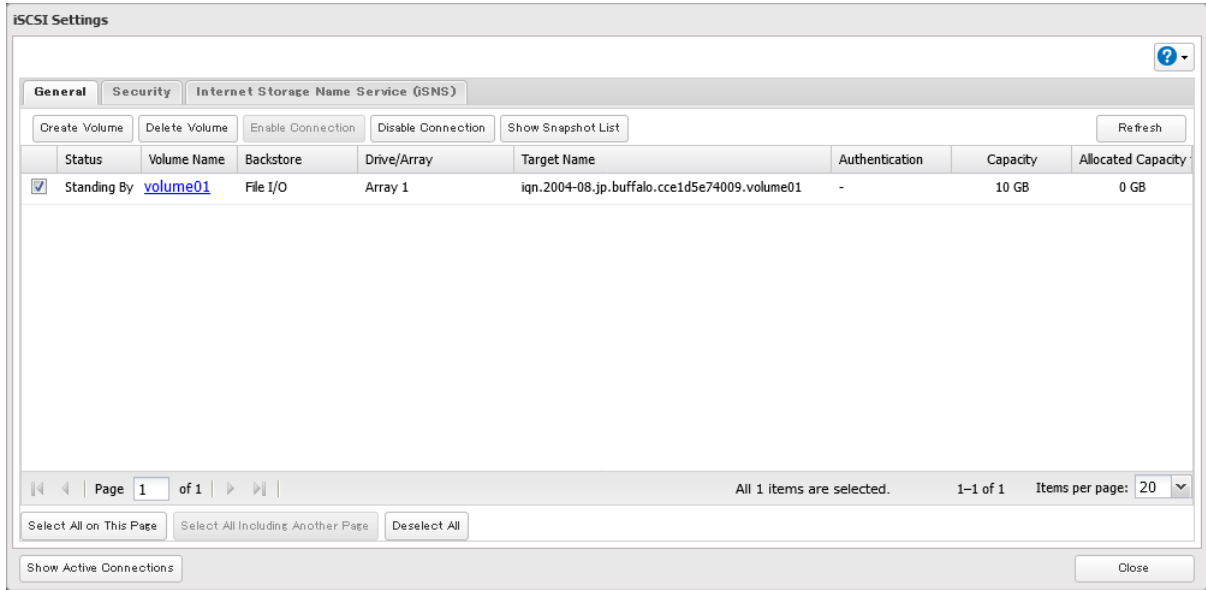

4 Select the checkbox for the target snapshot and then click *Restore*.

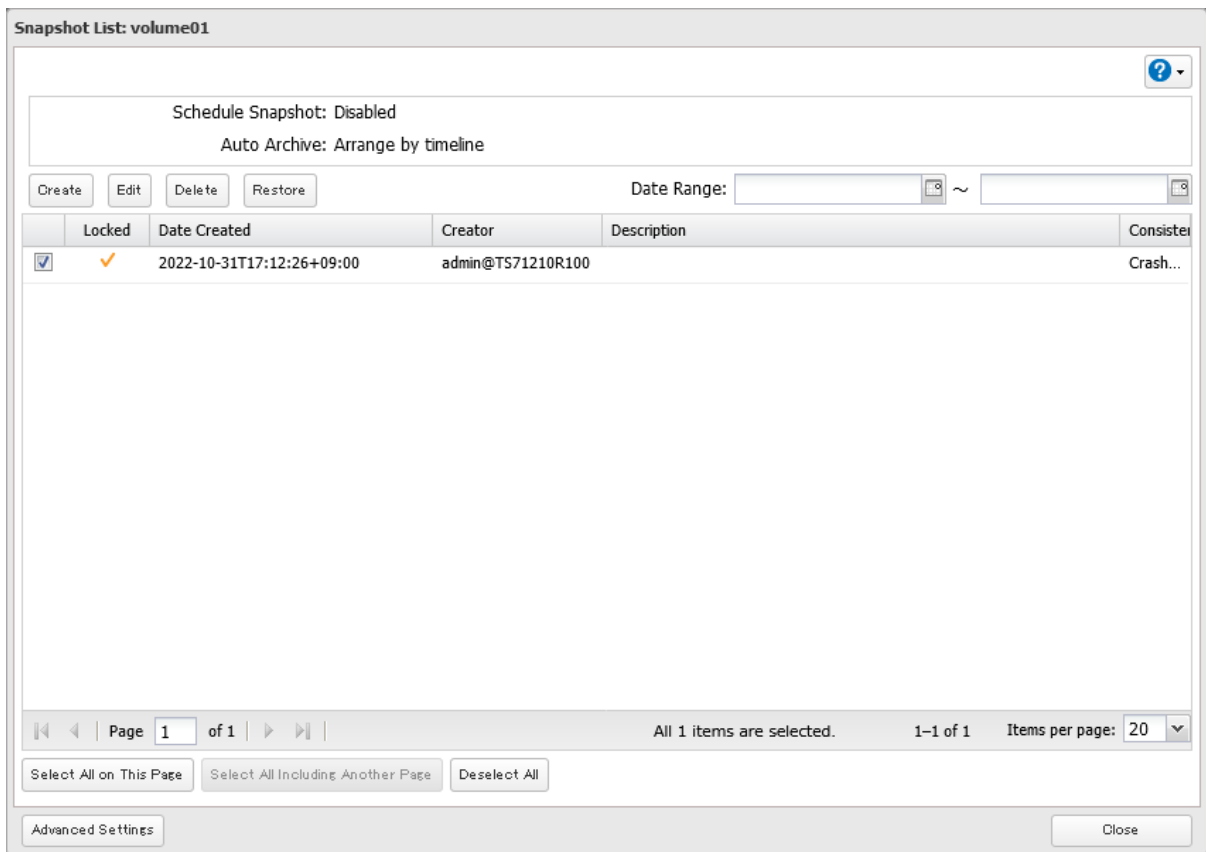

- 5** A new snapshot will be created before restoring the snapshot. Select or clear the “Lock” checkbox to determine whether the created snapshot will be locked or unlocked and enter a short description, then click *OK*. A locked snapshot cannot be deleted due to auto-archiving.

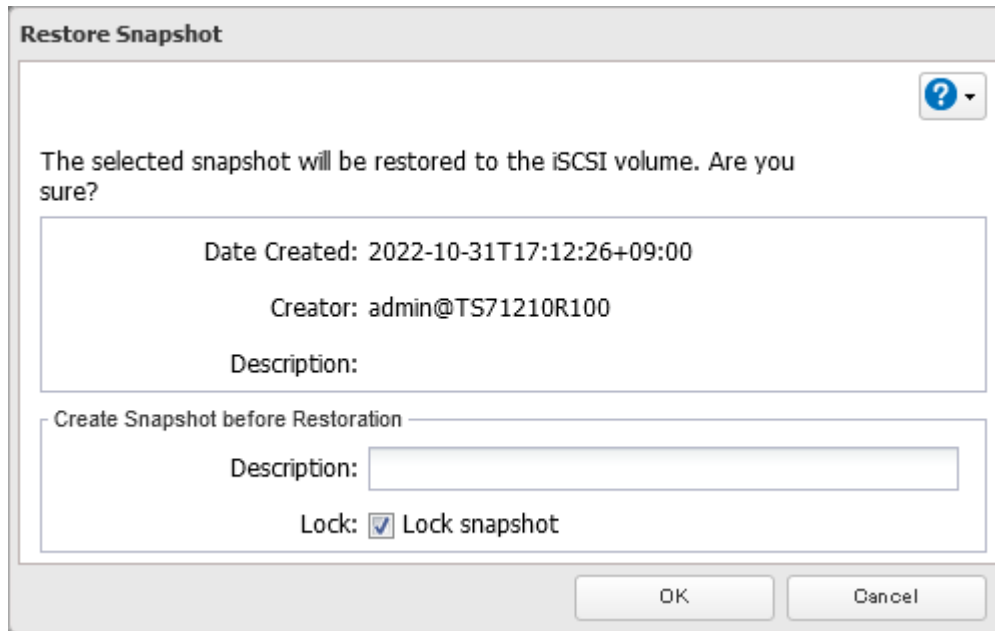

- 6** The process is complete once you close the confirmation window that appears.

Configuring Schedule Snapshot

If you want to create a snapshot for the purpose of regular backups, follow the procedure below.

For Shared Folders

- 1** From Settings, click *File Sharing*.

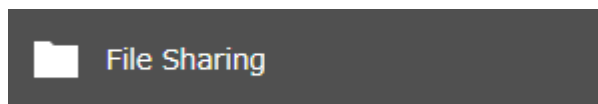

- 2** Click the settings icon (⚙️) to the right of “Folder Setup”.



3 Click the number under “Snapshot” for the shared folder on the shared folder list.

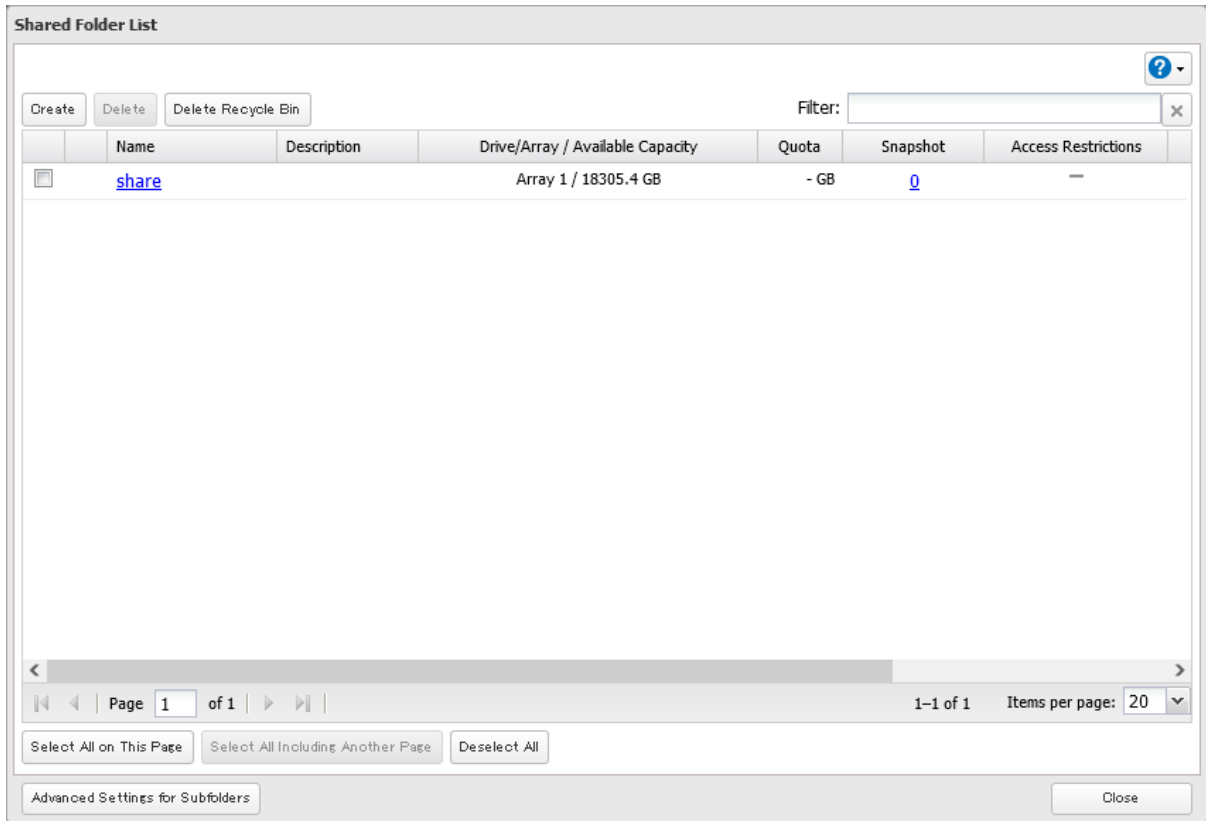

4 Click *Advanced Settings* at the lower-left corner of the window.

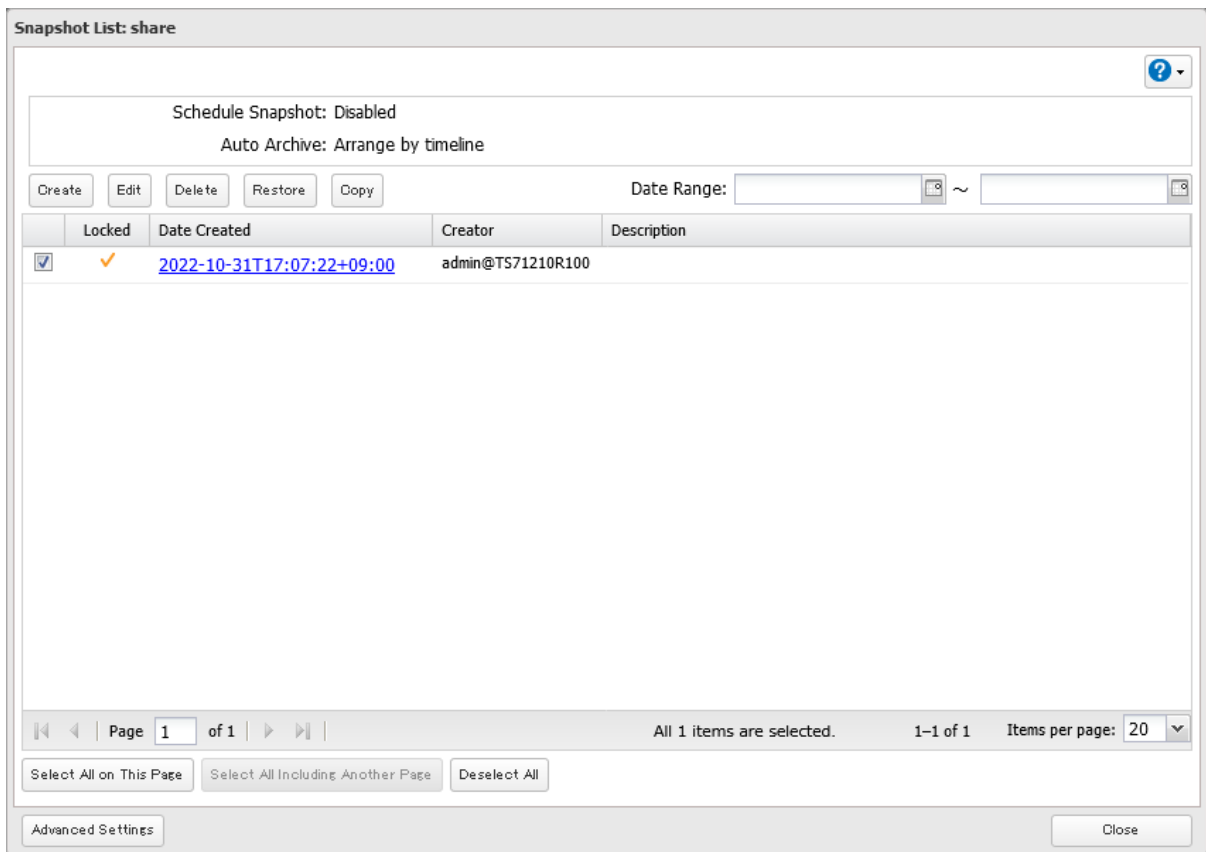

5 Enable “Schedule Snapshot”.

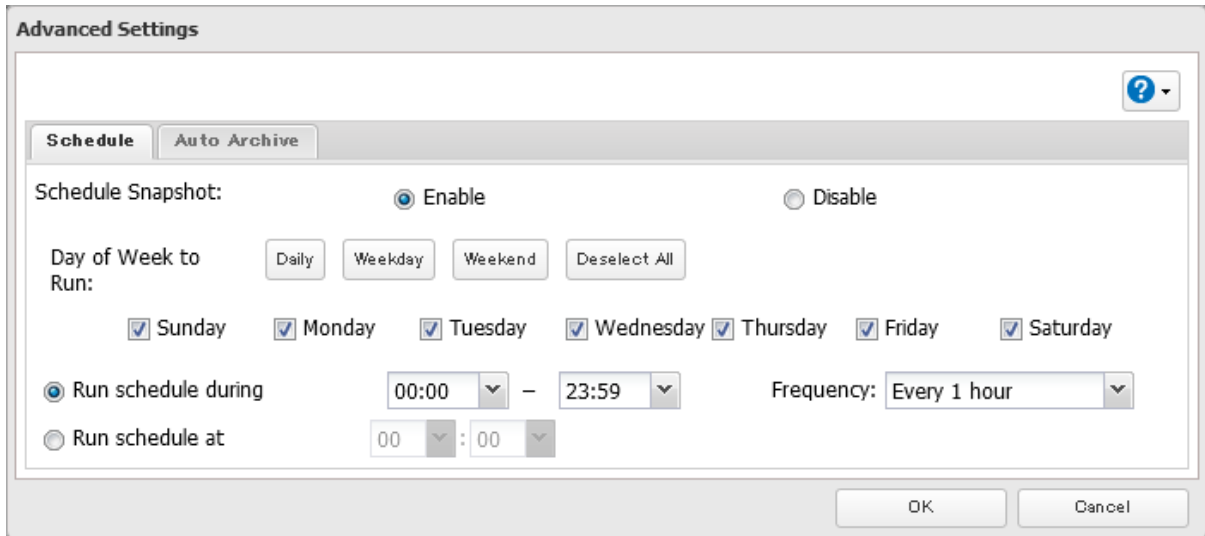

Advanced Settings

Schedule | Auto Archive

Schedule Snapshot: Enable Disable

Day of Week to Run:

Sunday Monday Tuesday Wednesday Thursday Friday Saturday

Run schedule during – Frequency:

Run schedule at :

6 Select the day of the week and time for when to have a snapshot automatically created, then click *OK*.

7 The process is complete once you close the confirmation window that appears.

For iSCSI Volumes

1 From Settings, click *Storage*.



2 Click the settings icon () to the right of “iSCSI”.



3 Select the checkbox for the target iSCSI volume and click *Show Snapshot List*.

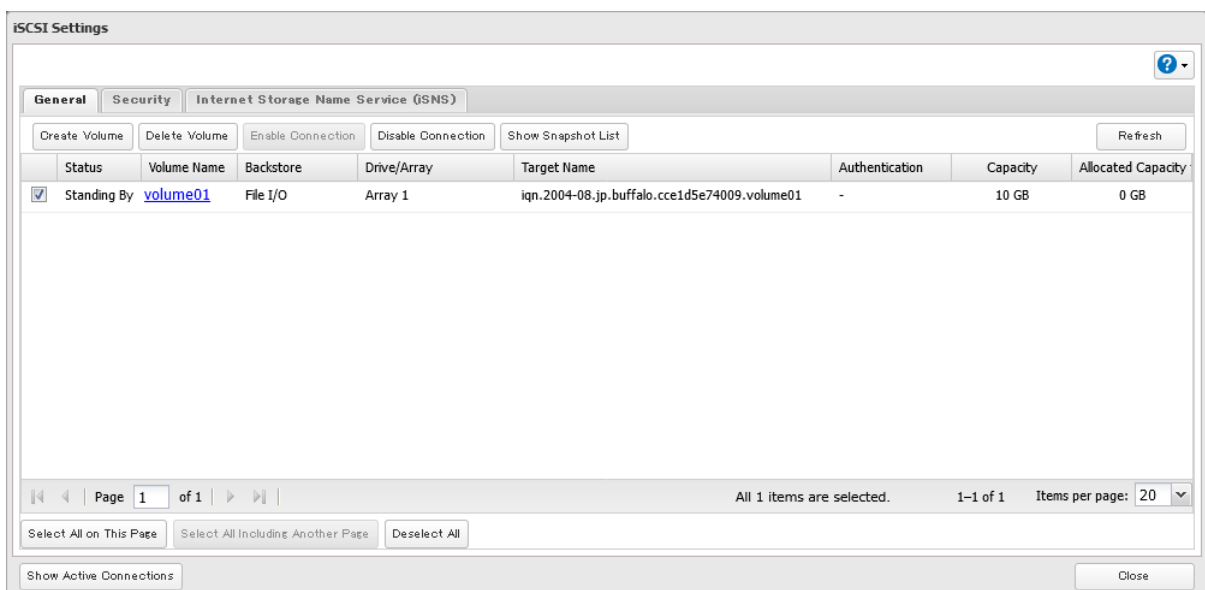

iSCSI Settings

General | Security | Internet Storage Name Service (iSNS)

Status	Volume Name	Backstore	Drive/Array	Target Name	Authentication	Capacity	Allocated Capacity
<input checked="" type="checkbox"/>	Standing By volume01	File I/O	Array 1	iqn.2004-08.jp.buffalo.cce1d5e74009.volume01	-	10 GB	0 GB

Page 1 of 1 | All 1 items are selected. | 1-1 of 1 | Items per page: 20

4 Click *Advanced Settings* at the lower-left corner of the window.

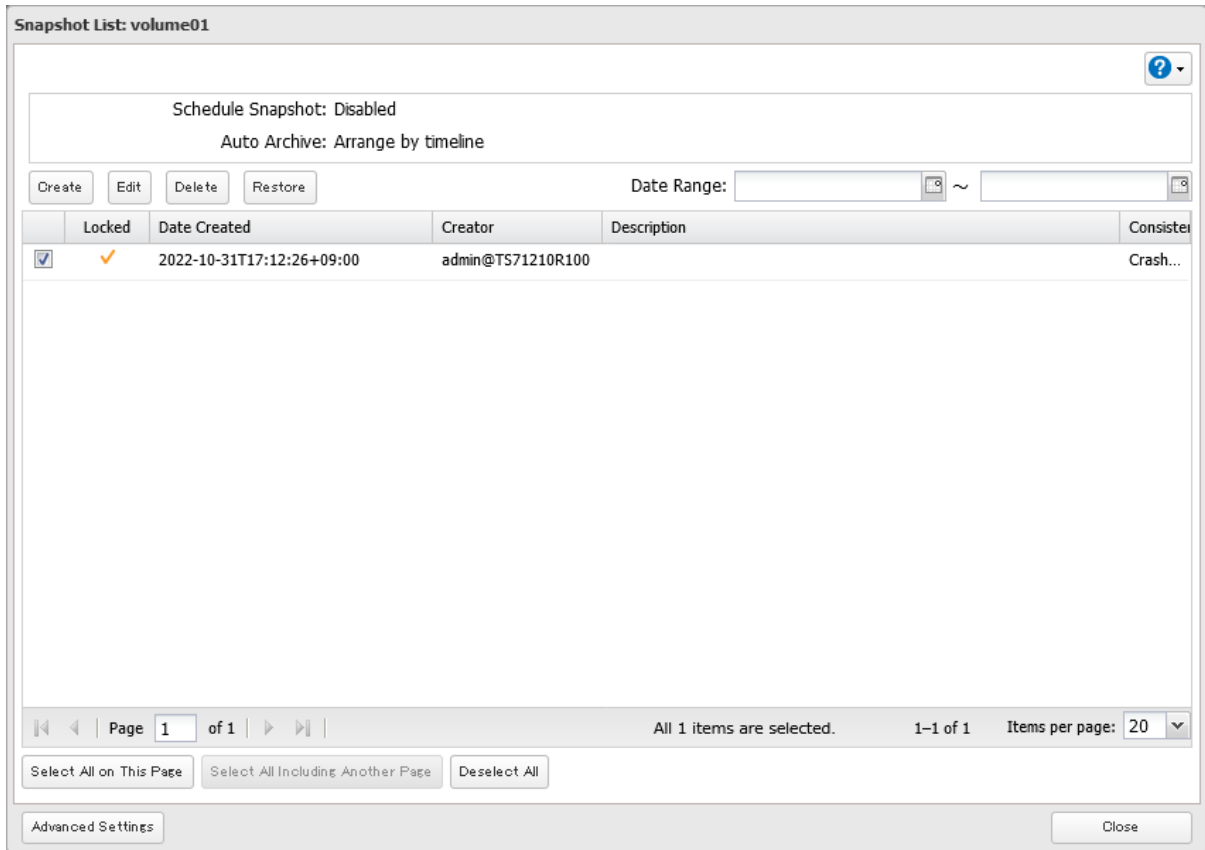

5 Enable “Schedule Snapshot”.

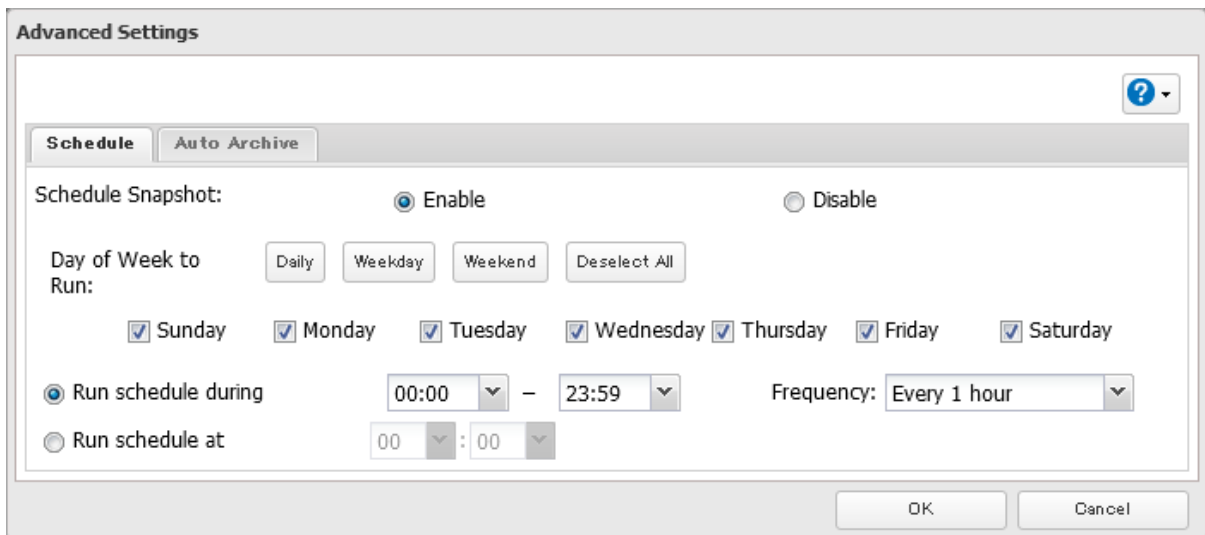

6 Select the day of the week and time when to automatically create a snapshot, then click *OK*.

7 The process is complete once you close the confirmation window that appears.

Configuring Snapshot Archive Settings

If you regularly create snapshots, it will use up capacity on the TeraStation. Snapshot archive settings will allow you to save capacity on created snapshots by automatically deleting older snapshots. You can set either a version-based or a timeline-based rule to delete snapshots.

Note: The locked snapshots will be kept even if archive settings are in effect.

For Shared Folders

1 From Settings, click *File Sharing*.

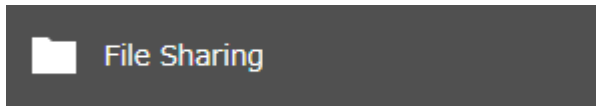

2 Click the settings icon (⚙️) to the right of "Folder Setup".



3 Click the number under "Snapshot" for the shared folder on the shared folder list.

Shared Folder List

Create Delete Delete Recycle Bin Filter:

	Name	Description	Drive/Array / Available Capacity	Quota	Snapshot	Access Restrictions
<input type="checkbox"/>	share		Array 1 / 18305.4 GB	- GB	0	—

Page 1 of 1 1-1 of 1 Items per page: 20

Select All on This Page Select All Including Another Page Deselect All

Advanced Settings for Subfolders Close

4 Click *Advanced Settings* at the lower-left corner of the window.

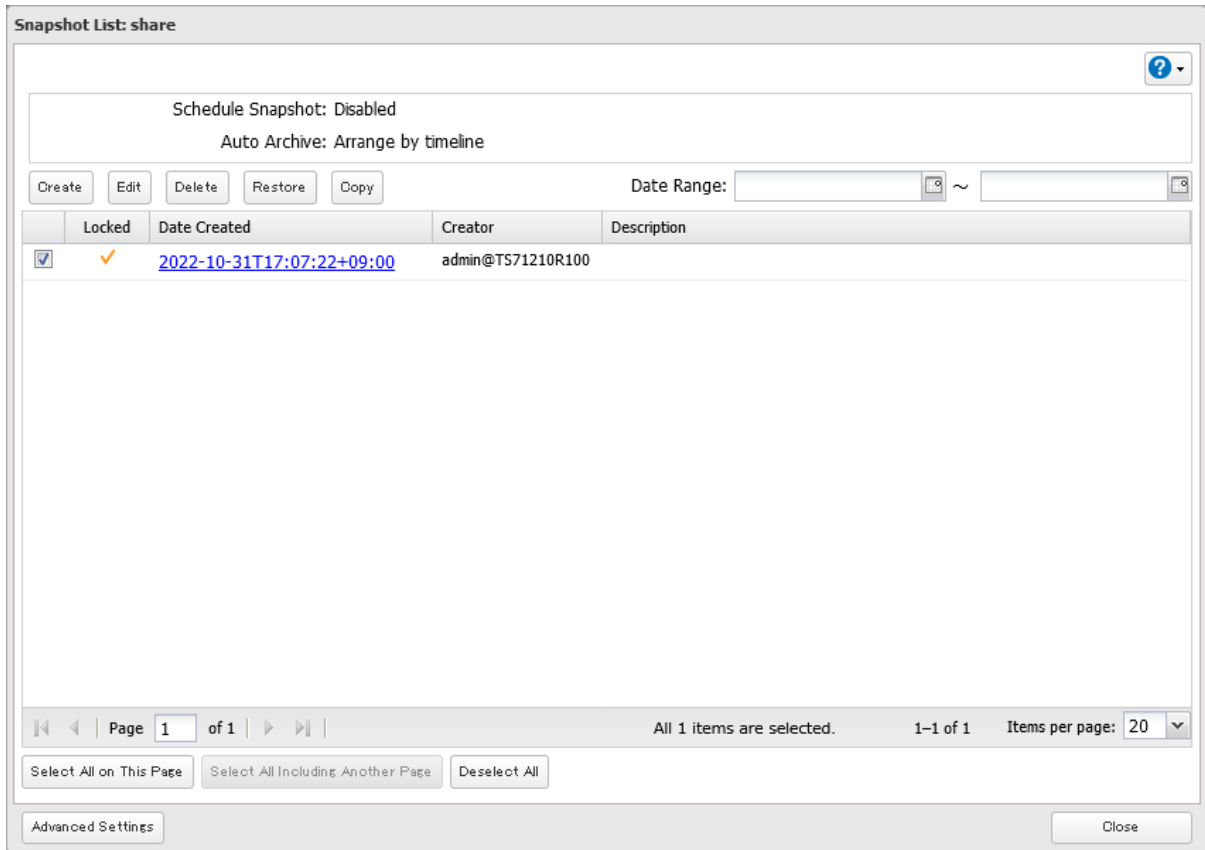

5 Click the *Auto Archive* tab.

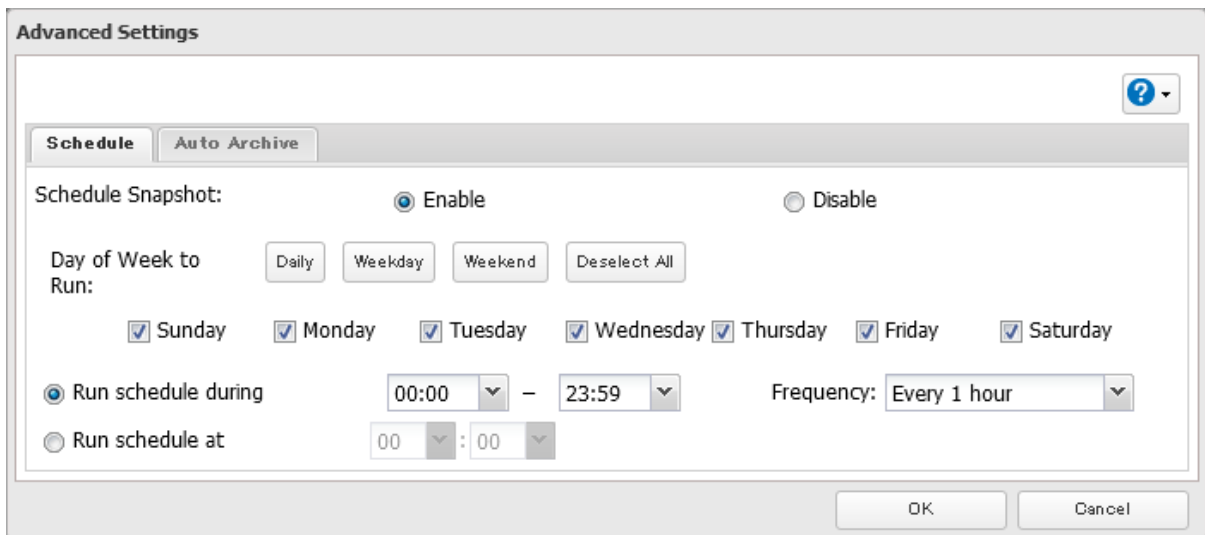

- 6** Select the rule to keep the snapshots and click *OK*. For more detailed information on archiving snapshots, refer to the [“Archive Rules for Snapshots”](#) section below.

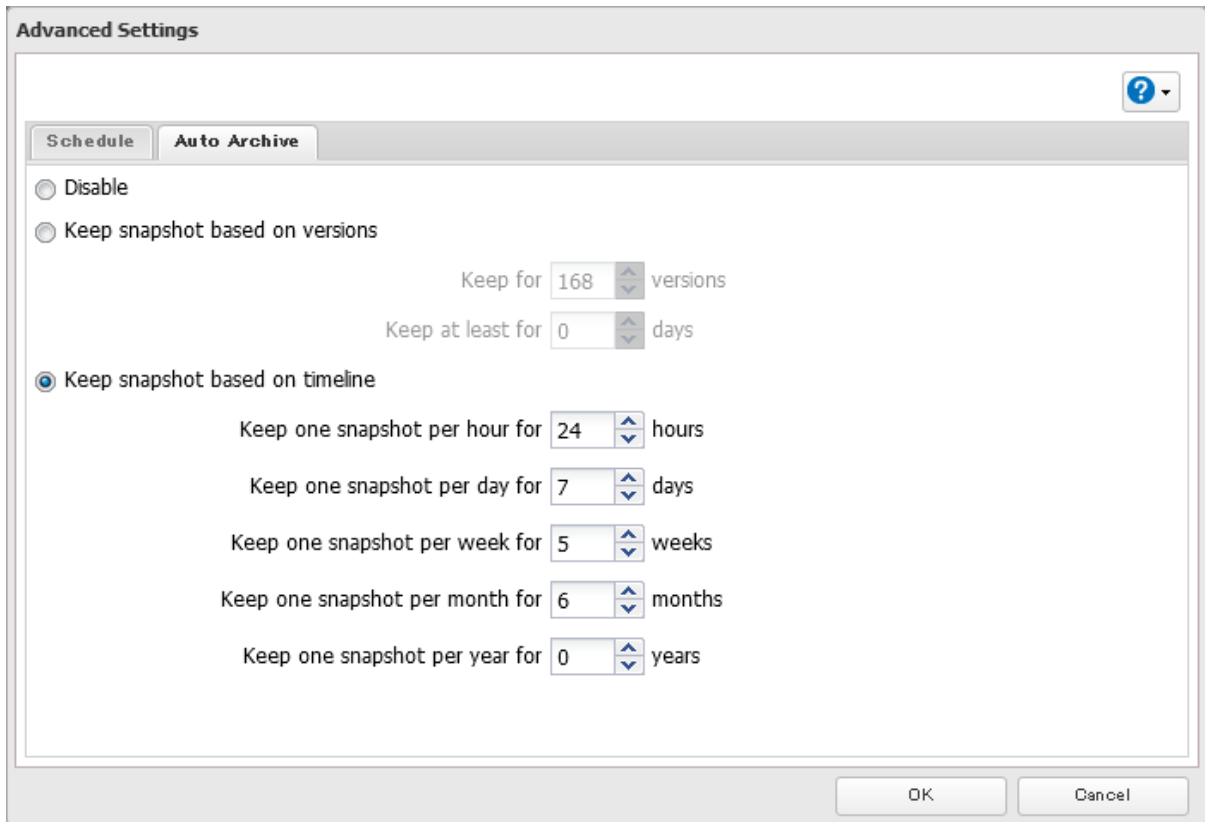

- 7** Select either *Yes* or *No* to apply the new snapshot archive settings to the existing snapshots.

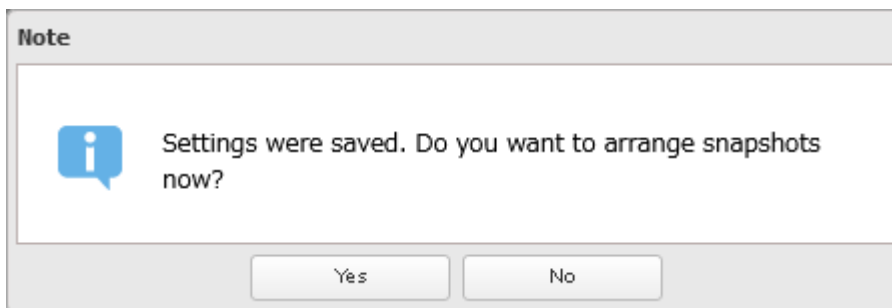

- 8** The process is complete once you close the confirmation window that appears.

For iSCSI Volumes

- 1** From Settings, click *Storage*.



- 2** Click the settings icon (⚙️) to the right of “iSCSI”.



3 Select the checkbox for the target iSCSI volume and click *Show Snapshot List*.

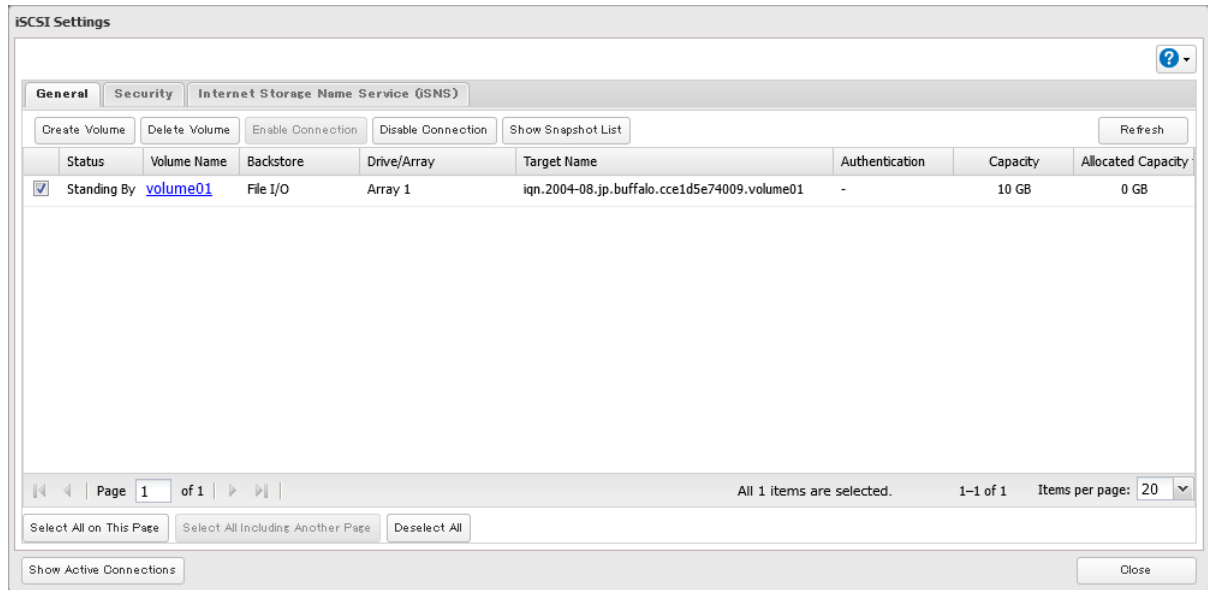

4 Click *Advanced Settings* at the lower-left corner of the window.

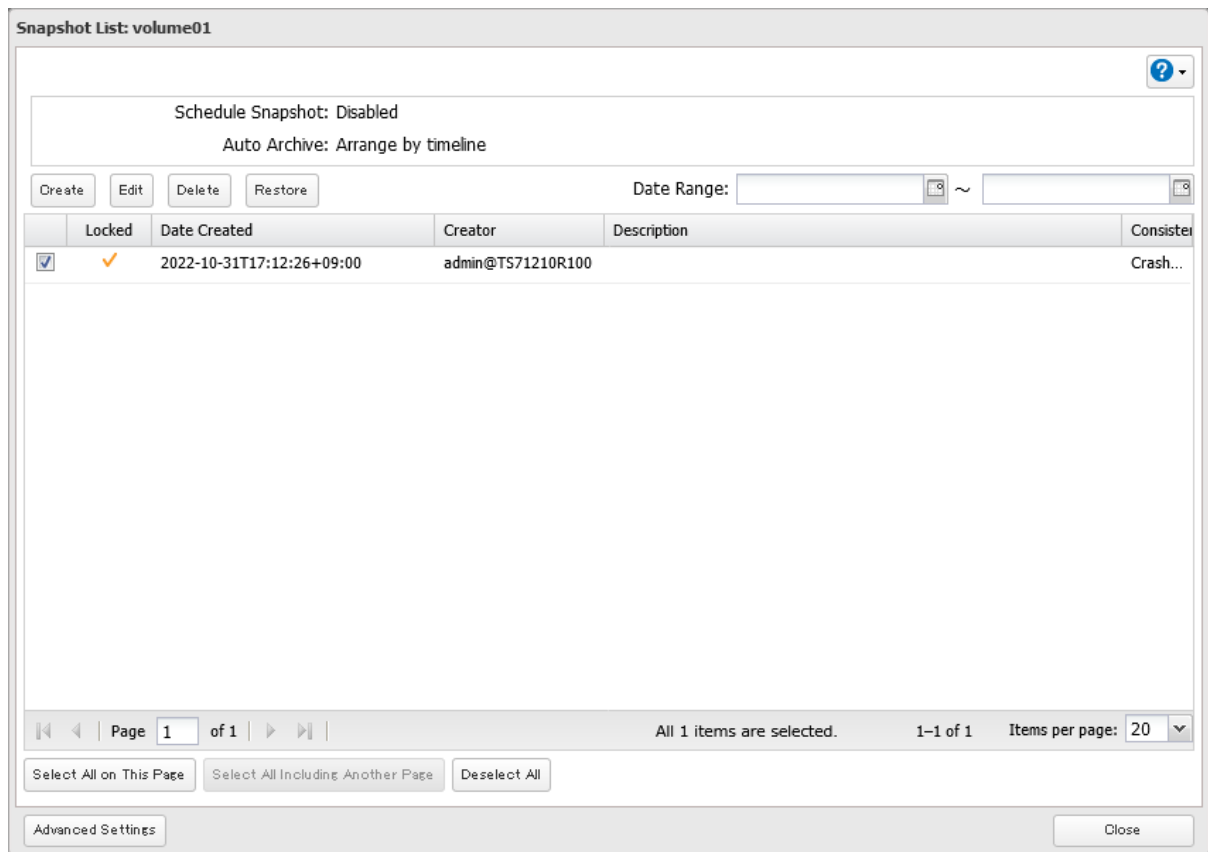

5 Click the *Auto Archive* tab.

Advanced Settings

Schedule | **Auto Archive**

Schedule Snapshot: Enable Disable

Day of Week to Run:

Sunday Monday Tuesday Wednesday Thursday Friday Saturday

Run schedule during 00:00 – 23:59 Frequency: Every 1 hour

Run schedule at 00 : 00

OK Cancel

6 Select the rule to keep the snapshots and click *OK*. For more detailed information on archiving snapshots, refer to the [“Archive Rules for Snapshots”](#) section below.

Advanced Settings

Schedule | **Auto Archive**

Disable

Keep snapshot based on versions

Keep for 168 versions

Keep at least for 0 days

Keep snapshot based on timeline

Keep one snapshot per hour for 24 hours

Keep one snapshot per day for 7 days

Keep one snapshot per week for 5 weeks

Keep one snapshot per month for 6 months

Keep one snapshot per year for 0 years

OK Cancel

- 7** Select either *Yes* or *No* to apply the new snapshot archive settings to the existing snapshots.

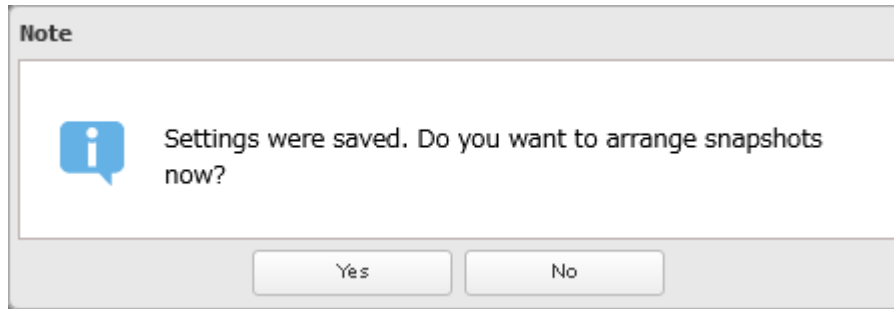

- 8** The process is complete once you close the confirmation window that appears.

Archive Rules for Snapshots

Version-Based

If you enter specific versions, the snapshots created from the latest up to the entered versions will be kept. Snapshots that don't match the version will not be removed. There is an option to exclude from the target versions until a set number of days has passed. If you set this option and the specified days haven't passed yet, the snapshots will be kept even if they match the target versions to be deleted.

Timeline-Based

This rule uses a timeline of when the snapshot was created to keep snapshots. Using this rule will keep any snapshots created at closest to 0 minutes on the hour and 12:00 a.m. (midnight) on the day.

The following example illustrates a scenario of when a snapshot is regularly created during 12:00 a.m. to 11:00 p.m. for every hour everyday and the default archive rule is used, for 24 hours, 7 days, 5 weeks, 6 months, and 0 years.

Current time: 31st, 11:59 p.m.

	Mon	Tue	Wed	Thu	Fri	Sat	Sun
1st	1 12:00 a.m.	2	3	4	5	6	7
2nd	8 12:00 a.m.	9	10	11	12	13	14
3rd	15 12:00 a.m.	16	17	18	19	20	21
4th	22 12:00 a.m.	23	24	25 12:00 a.m.	26 12:00 a.m.	27 12:00 a.m.	28 12:00 a.m.
5th	29 12:00 a.m.	30 12:00 a.m.	31 12:00 a.m.				

Snapshots created every hour between 12:00 a.m. to 11:00 p.m. today are kept by matching the hour-based rule. One snapshot per day is also kept for the last seven days by matching the day-based rule. One snapshot on every Monday is also kept for the last five weeks by matching the week-based rule. One snapshot on every first day of the month is also kept for six months by matching the month-based rule. If you change the year-based rule from the default settings, one snapshot on January 1st will also be kept for the specified years.

Backing Up Data on the TeraStation

You can back up the TeraStation folders to another shared folder on the same TeraStation, a connected USB drive, or a shared folder on another Buffalo NAS device, either on the same network or on another network.

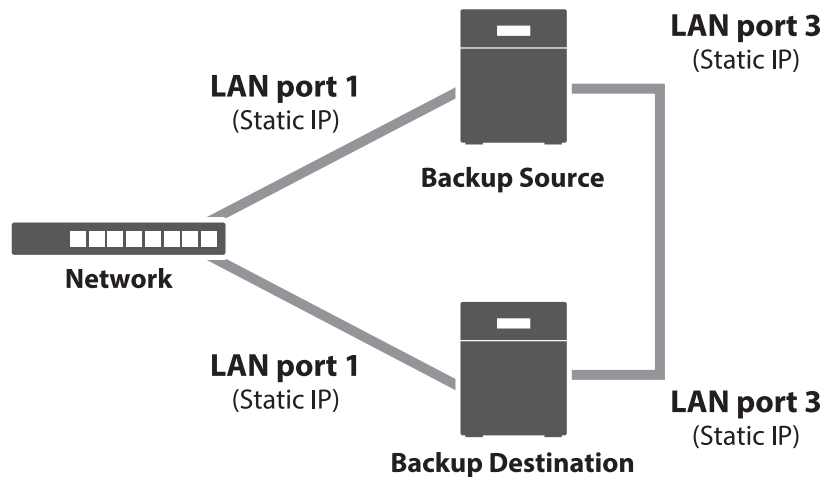

Backup Modes

The following types of backup are available from this TeraStation. To restore data from backup, refer to the [“Restoring Backup Data”](#) section below.

Full Backup

All files in the source will be backed up to the destination. You can specify how many backup versions to keep from 1–400, or select “Unlimited” to keep all backups until the drive is full. If you specify a number of backup versions, the backup destination folder should be on the same TeraStation or on an external USB drive attached to that TeraStation.

The backup data will be stored in the folder whose name will be the backup date and time.

- **Folders available as backup sources:**
 - Shared folder on the backup source TeraStation
 - USB drive connected to the backup source TeraStation^{*1}
 - Shared folder on another Buffalo NAS device^{*2}
 - Shared folder on another rsync-compatible device
- **Folders available as backup destinations:**
 - Shared folder on the backup source TeraStation^{*2}
 - USB drive connected to the backup source TeraStation^{*2,3}
 - Shared folder on another Buffalo NAS device^{*2,4}
 - Shared folder on another rsync-compatible device

*1 You can select up to the second level of folders. However, if the folder name of a second level folder contains symbols, that folder may not appear as the target folder.

*2 The folder should have the “Backup” checkbox selected under “LAN Protocol Support” on the shared folder settings.

*3 If the “Inherit subfolders’ access restrictions” option is selected when creating a backup job, use Btrfs, XFS, or ext3 file systems.

*4 If the “Inherit subfolders’ access restrictions” option is selected when creating a backup job, the device should be a Buffalo NAS device whose subfolders’ access restrictions is available.

Overwrite (Incremental)

The first backup job runs like a full backup. As each subsequent backup job runs, only files that have been changed since the last full backup will be backed up, but any files deleted from the backup source folder will also remain in the backup destination folder. The folder structure in the backup destination folder will be the same as the backup source folder.

- **Folders available as backup sources:**
 - Shared folder on the backup source TeraStation

- USB drive connected to the backup source TeraStation*¹
- Shared folder on another Buffalo NAS device*²
- Shared folder on another rsync-compatible device
- **Folders available as backup destinations:**
 - Shared folder on the backup source TeraStation*²
 - USB drive connected to the backup source TeraStation*^{2,3}
 - Shared folder on another Buffalo NAS device*^{2,4}
 - Shared folder on another rsync-compatible device

*1 You can select up to the second level of folders. However, if the folder name of a second level folder contains symbols, that folder may not appear as the target folder.

*2 The folder should have the “Backup” checkbox selected under “LAN Protocol Support” on the shared folder settings.

*3 If the “Inherit subfolders' access restrictions” option is selected when creating a backup job, use Btrfs, XFS, or ext3 file systems.

*4 If the “Inherit subfolders' access restrictions” option is selected when creating a backup job, the device should be a Buffalo NAS device whose subfolders' access restrictions is available.

Overwrite (Differential)

The first backup job runs like a full backup. As each subsequent backup job runs, only files that have been changed since the last full backup will be backed up, and any files deleted from the backup source folder will also be deleted from the backup destination folder. The backup destination folder will always remain the same size as the backup source folder, and the folder structure in the backup destination folder will be the same as the backup source folder.

- **Folders available as backup sources:**
 - Shared folder on the backup source TeraStation
 - USB drive connected to the backup source TeraStation*¹
 - Shared folder on another Buffalo NAS device*²
 - Shared folder on another rsync-compatible device
- **Folders available as backup destinations:**
 - Shared folder on the backup source TeraStation*²
 - USB drive connected to the backup source TeraStation*^{2,3}
 - Shared folder on another Buffalo NAS device*^{2,4}
 - Shared folder on another rsync-compatible device

*1 You can select up to the second level of folders. However, if the folder name of a second level folder contains symbols, that folder may not appear as the target folder.

*2 The folder should have the “Backup” checkbox selected under “LAN Protocol Support” on the shared folder settings.

*3 If the “Inherit subfolders' access restrictions” option is selected when creating a backup job, use Btrfs, XFS, or ext3 file systems.

*4 If the “Inherit subfolders' access restrictions” option is selected when creating a backup job, the device should be a Buffalo NAS device whose subfolders' access restrictions is available.

Management Backup

Each time a backup is executed, management information is stored, and only files that have changed are backed up. Data is retrieved from the previous backup file for files that were not changed, which can help reduce the space used for backup and also for referencing status at a particular point in time (for data snapshot applications). You can specify how many backup versions to keep from 1–400, or select “Unlimited” to keep all backups until the drive is full. If using an external USB drive as the backup destination, do not use folders from drives formatted with FAT. The backup data will be stored in the folder whose name will be the backup date and time, and the destination folder will be set to read-only.

- **Folders available as backup sources:**
 - Shared folder on the backup source TeraStation
 - USB drive connected to the backup source TeraStation*¹

- Shared folder on another Buffalo NAS device^{*2}
- Shared folder on another rsync-compatible device
- **Folders available as backup destinations:**
 - Shared folder on the backup source TeraStation^{*2}
 - USB drive connected to the backup source TeraStation^{*2, 3, 4}

*1 You can select up to the second level of folders. However, if the folder name of a second level folder contains symbols, that folder may not appear as the target folder.

*2 The folder should have the “Backup” checkbox selected under “LAN Protocol Support” on the shared folder settings.

*3 If the “Inherit subfolders' access restrictions” option is selected when creating a backup job, use Btrfs, XFS, or ext3 file systems.

*4 The compatible file systems are ext3, XFS, Btrfs, and NTFS.

Note: For the destination folder, do not use a folder that has already been used as a target folder for another backup job. If you wish to use a folder that currently contains backup data as the destination folder for another backup job, format the folder first, or delete all data in the destination folder and change the folder attribute to read and write before configuring the folder as the destination folder.

Snapshot Backup

Files and snapshots on the backup source will be backed up to the backup destination. Each backup job will create a snapshot before the job runs.

The first backup job runs like a full backup. As each subsequent backup job runs, only files that have been changed since the last backup will be backed up, and any files deleted from the backup source folder will also be deleted from the backup destination folder. The folder structure in the backup destination folder will be the same as the backup source folder.

- **Folders available as backup sources:**
 - Shared folder on the backup source TeraStation*
 - Shared folder on another Buffalo NAS device*, **
- **Folders available as backup destinations:**
 - Shared folder on the backup source TeraStation*, **
 - Shared folder on another Buffalo NAS device*, **, ***

*The folders should be created on a Btrfs-formatted area.

**The folder should have the “Backup” checkbox selected under “LAN Protocol Support” on the shared folder settings.

***If the “Inherit subfolders' access restrictions” option is selected when creating a backup job, the device should be a Buffalo NAS device whose subfolders' access restrictions is available.

Notes:

- The number of snapshots kept after backing up to the backup destination will vary depending on the auto-archive settings. If the backup snapshot versions are later than the versions on the backup destination, they will overwrite the earlier snapshot versions. Configure more versions to be kept on the backup destination than the backup source.
- If you want to see the history of snapshots on the backup destination folder, use shadow copy or click *Restore* in Settings. Refer to the [“Snapshots”](#) section above.

iSCSI Backup

Imaged iSCSI volume data will be backed up. Each backup job will create a snapshot before the job runs. The backup source and backup destination can be paired and configured together. Backing up an iSCSI volume will create a “fileio” file in the backup destination shared folder.

The first backup job runs like a full backup. As each subsequent backup job runs, only files that have been changed since the last full backup will be backed up, and any files deleted from the backup source folder will also be deleted from the backup destination folder.

- **Folders available as backup sources:**

- Shared folder on the backup source TeraStation*
- Shared folder on another Buffalo NAS device*, **
- The iSCSI file I/O volume on the backup source TeraStation*
- **Folders available as backup destinations:**
 - Shared folder on the backup source TeraStation*, **
 - Shared folder on another Buffalo NAS device*, **, ***
 - The iSCSI file I/O volume on the backup source TeraStation*

*The folders should be created on a Btrfs-formatted area.

**The folder should have the “Backup” checkbox selected under “LAN Protocol Support” on the shared folder settings.

***If the “Inherit subfolders' access restrictions” option is selected when creating a backup job, the device should be a Buffalo NAS device whose subfolders' access restrictions is available.

Notes:

- The number of snapshots kept after backing up to the backup destination will vary depending on the auto-archive settings. If the backup snapshot versions are later than the versions on the backup destination, they will overwrite the earlier snapshot versions.
- If you select a shared folder as a backup source, only an iSCSI volume can be selected as a backup destination and vice versa. The same type of folders cannot be used in an iSCSI backup job.

Preparing a Backup Destination

Configure a shared folder on a Buffalo NAS device or connected USB drive as a backup destination. The following procedure explains using another shared folder on the TeraStation as a backup destination. The procedure may vary depending on which Buffalo NAS device is selected as a destination. If using a USB drive as a backup destination, make sure its attribute is set to read and write. To change a read-only USB drive's attribute to read and write, refer to the [“Read-Only Shares”](#) section in chapter 4.

If you would like to back up data from multiple backup sources, we recommend not using the same backup destination, as data in the backup destination may be overwritten by subsequent backup jobs. If you must back up data from multiple backup sources to the same backup destination, using management backup is recommended for precise version control.

Note: If you want to set this TeraStation as the backup destination for an rsync-compatible device, refer to the [“If Backing Up from rsync-Compatible Devices to the TeraStation”](#) section instead of following the procedure below.

- 1 From Settings, click *File Sharing*.

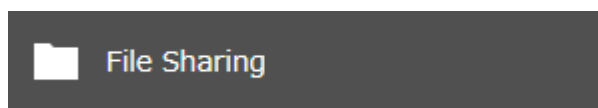

- 2 Click the settings icon () to the right of “Folder Setup”.

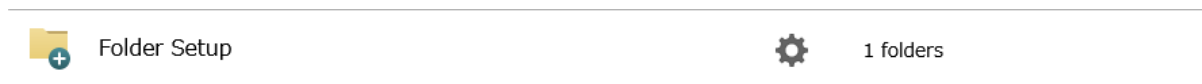

3 Choose the folder to be set as a backup destination.

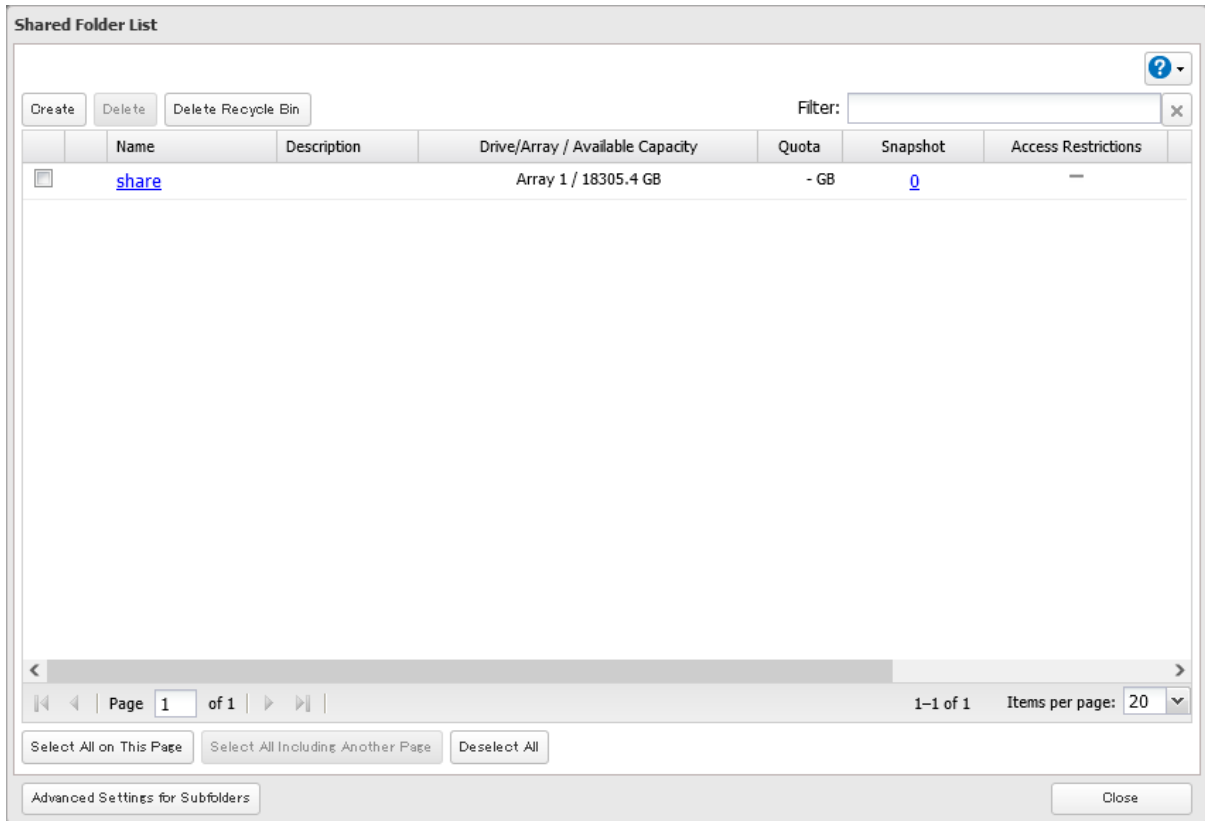

4 Under "LAN Protocol Support", select the "Backup" checkbox on the *Basic* tab.

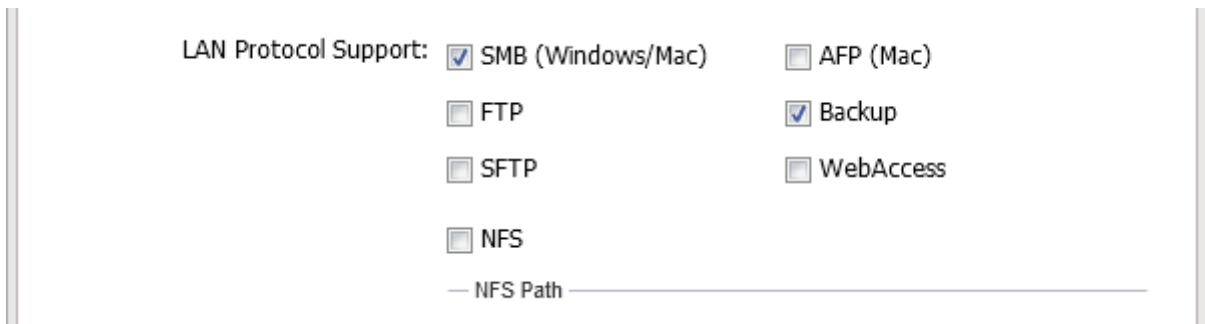

5 Click *OK* and proceed to the next step to create a backup device access key.

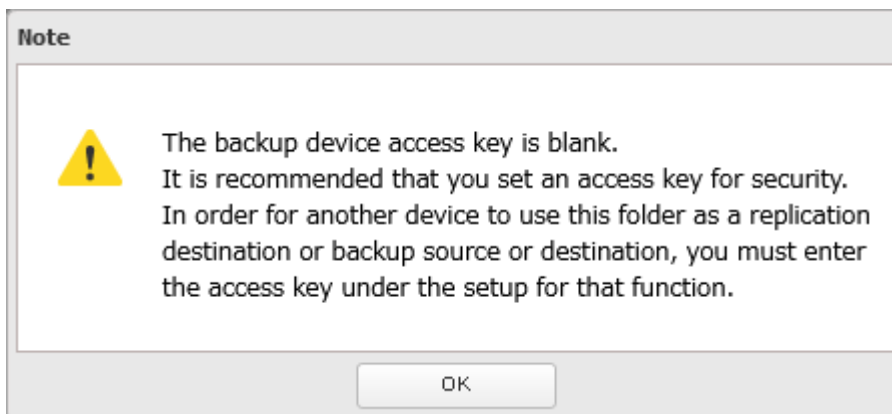

6 Enter the desired characters into the backup device access key field and click *OK*.

Backup Device Access Key:

Note: You may leave this field blank if you do not want a backup device access key, but for security reasons we highly recommend entering one for the shared folder. If a backup device access key is configured for the shared folder, that folder will not show up as a target for the backup source or destination when configuring a backup job on another Buffalo NAS device unless it's entered. You may create multiple folders using different backup device access keys for backup and replication, but only one access key can be used on the TeraStation. Folders that are configured with a different access key cannot be used.

7 The process is complete once you close the confirmation window that appears.

Notes:

- If you want to back up to a Buffalo NAS device on another network, follow the procedure below to add the Buffalo NAS device so it can be used as a backup destination.
 - (1) Create a new backup job by referring to the [“Configuring a Backup Job”](#) section below.
 - (2) On the screen that allows you to select a shared folder, click *List of Servers*.
 - (3) Click *Add*; select the “Add Buffalo NAS device” option, enter the IP address or hostname of the destination Buffalo NAS device, then click *OK*.
 - (4) Click *Close*.
 - (5) Click *Refresh* and make sure the desired Buffalo NAS device has been added to the list.
- If you want to back up to an rsync-compatible device, follow the procedure below to add the rsync-compatible device so it can be used as a backup destination.
 - (1) Create a new backup job by referring to the [“Configuring a Backup Job”](#) section below.
 - (2) On the screen that allows you to select a shared folder, click *List of Servers*.
 - (3) Click *Add*; select the “Add rsync-compatible device” option, enter the IP address or hostname of the destination device, then click *OK*. If you want to encrypt the rsync access, enable “rsync Over SSH” and enter the rsync account settings.
 If your rsync account username includes a symbol, first change the username to one that does not include any symbols.
 - (4) Click *Close*.
 - (5) Click *Refresh* and make sure the desired rsync-compatible device has been added to the list.
- Adding a target TeraStation’s IP address to the “List of Servers” and enabling rsync over SSH is required for snapshot and iSCSI backups, otherwise the target TeraStation will not appear as a backup destination.

Configuring a Backup Job

You can configure backup jobs by using another shared folder on the Buffalo NAS device or a USB drive connected to the TeraStation as a destination. You can also back up to a Buffalo NAS device on another network as long as the two networks are connected by a VPN or the route is configured properly.

1 From Settings, click *Backup*.



2 Click the settings icon () to the right of "Backup".



3 If you had configured a backup device access key for the backup source folder on another Buffalo NAS device or the backup destination folder, click *Set*. If you hadn't, skip to step 5.

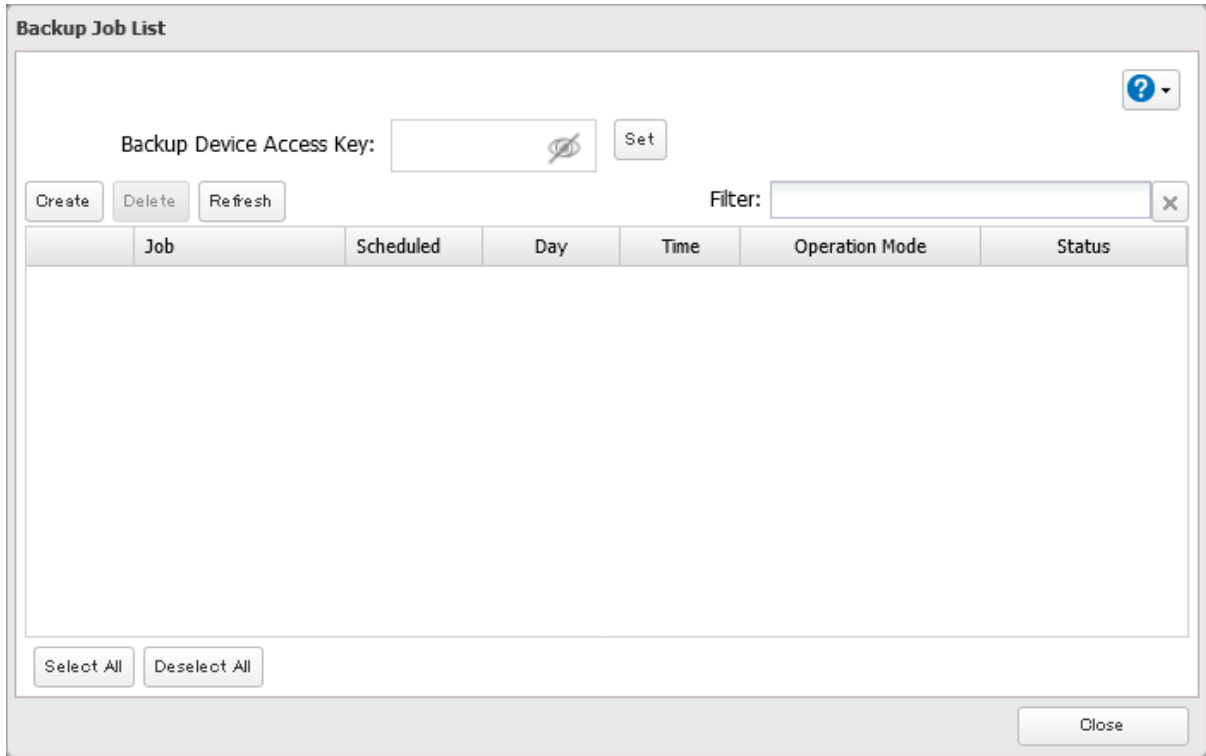

4 Enter the backup device access key and click *OK*.

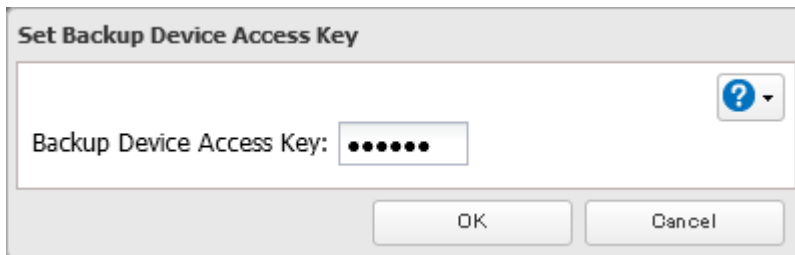

5 Click *Create*.

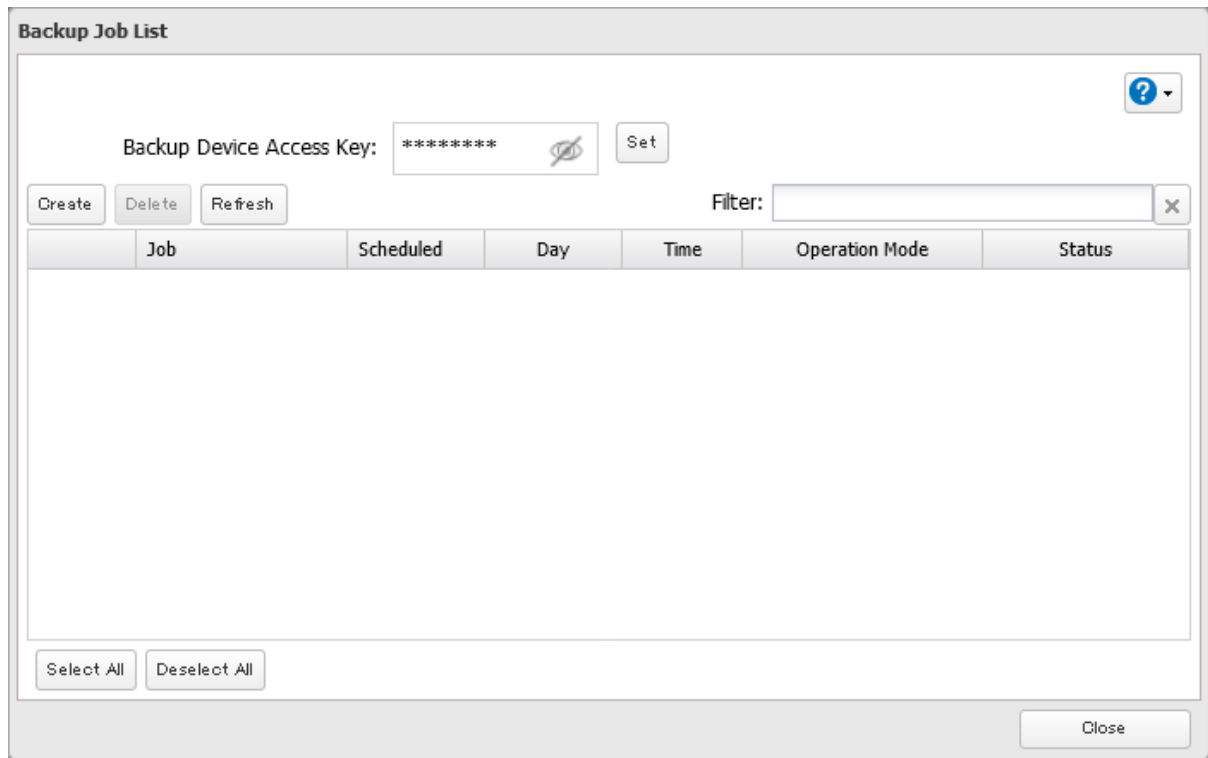

- 6** Select backup settings such as date and time to run, then select a backup mode for the “Operation Mode” drop-down list. Refer to the differences between the backup modes from the [“Backup Modes”](#) section above.

The screenshot shows the "Backup Job Settings" dialog box. At the top right, there is a red asterisk and the word "*Required" next to a help icon. The "Job Name *" field is empty. The "Schedule" is set to "Not scheduled", "Sunday", "00", and "00". The "Operation Mode" is set to "Full backup". The "Versions" are set to "10" with a checked "Unlimited" option. Below these fields is an "Options" section with several checkboxes: "Create a subfolder for backup" (checked), "Create backup log file" (checked), "Save backup logs in the backup source folder" (selected with a radio button), "Select the folder to save backup logs" (unselected), "Target Folder:" with a "Browse" button, "Encrypted data transfer" (unchecked), "Compress and transfer" (unchecked), "Ignore backup errors and continue backup job on schedule" (checked), "Do not back up recycle bin" (unchecked), "Overwrite unchanged files" (unchecked), "Inherit subfolders' access restrictions" (unchecked), and "Back up all snapshots" (unchecked). At the bottom right, there are "OK" and "Cancel" buttons.

- 7** Click *Add*.

8 Select the shared folders that will be the backup source and destination.

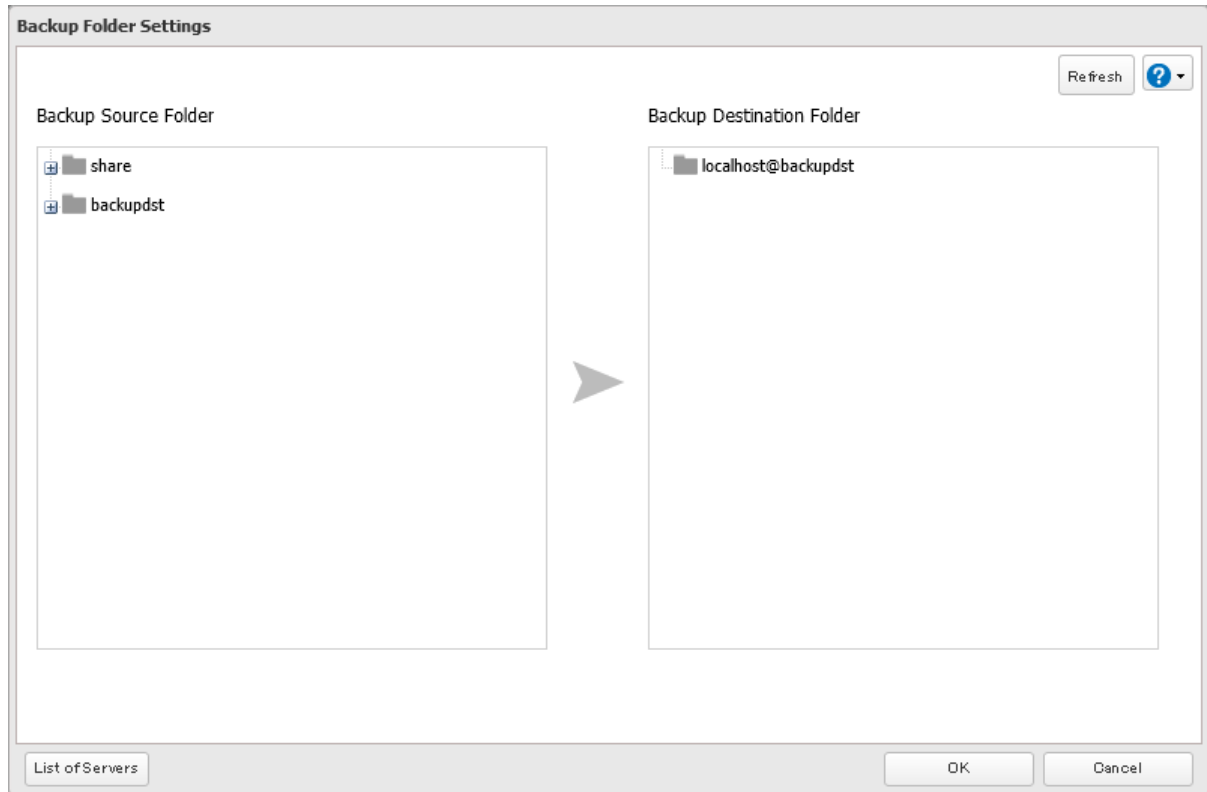

9 Click *OK*, then click *OK* again.

10 The process is complete once you close the confirmation window that appears. The backup job will be added to the backup jobs list.

Notes:

- Up to eight backup jobs can be configured at a time, and twenty-five backup source and destination folder pairs can be used in one backup job.
- During setup, you may choose to encrypt and/or compress backup data. Encrypted data will be transferred securely on the network. Compressed data will ease network loading and is recommended for slow or heavily-loaded network connections. Enabling either will increase the CPU load on the source TeraStation so that the transfer speed will become slower, and backup time will be slower than if they are disabled. Encrypted or compressed data will be decrypted or decompressed on the destination TeraStation.
- To inherit the subfolders' access restriction settings to the backup destination, the backup destination should also support the subfolders' access restrictions. Check it before creating a backup job.
- To back up data between Buffalo NAS devices on a network using jumbo frames, make sure that both devices are configured to use identical (or similar) MTU sizes. If MTU sizes are significantly different, the backup job may not be properly performed. In such a case, select the default MTU size (1,500 bytes) for both devices.
- You can also specify a hostname by a fully qualified domain name (FQDN).
- Windows-based TeraStations with multibyte characters in the hostname may not be detected as a backup destination, and folders in these devices cannot be used as backup destination folders.
- Backup data, such as ".DS_Store" files, from macOS may include characters that cannot be read on FAT32-formatted drives in its filename. For best results, reformat the drive before using it as a backup destination.
- You can specify the LAN port to use for backup such as "(LAN3)". If connecting to the same network using two or more LAN ports, configure each LAN port with a different network segment.
- If you also want to back up the subfolder's attributes (such as hidden files and read/write status) to the backup destination, select the "Inherit subfolders' access restrictions" option for backup options.

- If you directly connect this TeraStation's LAN port and another TeraStation's 1GbE LAN port using an Ethernet cable, shared folders on the other TeraStation will not be displayed as backup targets. In such a case, change the LAN port to one other than 1GbE or use a smart switch.

This behavior will affect the following target TeraStation models:

- TS5010 series (TS5210DN, TS5410DN, TS5410RN, TS5810DN, TS51210RH TeraStation models)
- TS3020 series (TS3220DN, TS3420DN, TS3420RN TeraStation models)
- TS3010 series (TS3210DN, TS3410DN, TS3410RN TeraStation models)

If Backing Up from rsync-Compatible Devices to the TeraStation

If you want to set an rsync-compatible device as the backup source and back up data on the rsync-compatible device to the TeraStation, you will need to enable rsync access on the TeraStation.

- 1 From Settings, click *File Sharing*.

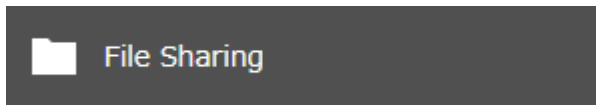

- 2 Click the settings icon () to the right of "rsync".



- 3 Enter this TeraStation's admin password into the "Password" field and click OK.

rsync Server Settings

*Required 

rsync Accounts

Username: admin

Password * :

Port Number: 873



SSH Settings

rsync Over SSH: Enable Disable

Port Number: 22

Authentication Method: Password authentication

Note: If you want to encrypt the rsync access, enable "rsync Over SSH".

- 4 The process is complete when you move the rsync switch () to the  position to enable rsync.



Restoring Backup Data

The procedure for restoring backup data varies depending on the backup mode. Refer to the appropriate subsection below corresponding to the backup mode you have used for backup. When restoring backup data, make sure you have enough available space on the TeraStation to accommodate the backup data, otherwise the restore process will fail.

Full and Management Backups

Copy and paste the backed up files from the backup destination folder to a folder which you want to restore.

Snapshot and Overwrite Backups (Incremental and Differential)

Files and folders, including snapshots, have already been stored on the desired destination. You can access them by switching the operation to the backup destination TeraStation. Alternatively, you can restore any files or folders by creating a backup job and configuring the backup destination as a backup source and selecting the same backup mode for the "Operation Mode" drop-down list. Do not use the same folder as the backup destination to restore backup data from multiple backup sources, as this may cause the restored data to get overwritten.

iSCSI Backups

The backup data can easily be restored by creating a new backup job. Follow the procedure below.

Make sure that there is an iSCSI file I/O volume on the TeraStation which you want to use for restoring the backup data. If you do not have one already, refer to the ["Creating an iSCSI Volume"](#) section in chapter 5 to create one. Please be aware that the existing iSCSI file I/O volume will be overwritten by the restored backup data.

- 1 From Settings, click *Backup*.



- 2 Click the settings icon () to the right of "Backup".



- 3 If you had configured a backup device access key for the backup source folder on another Buffalo NAS device or the backup destination folder, click *Set*. If you hadn't, skip to step 5.

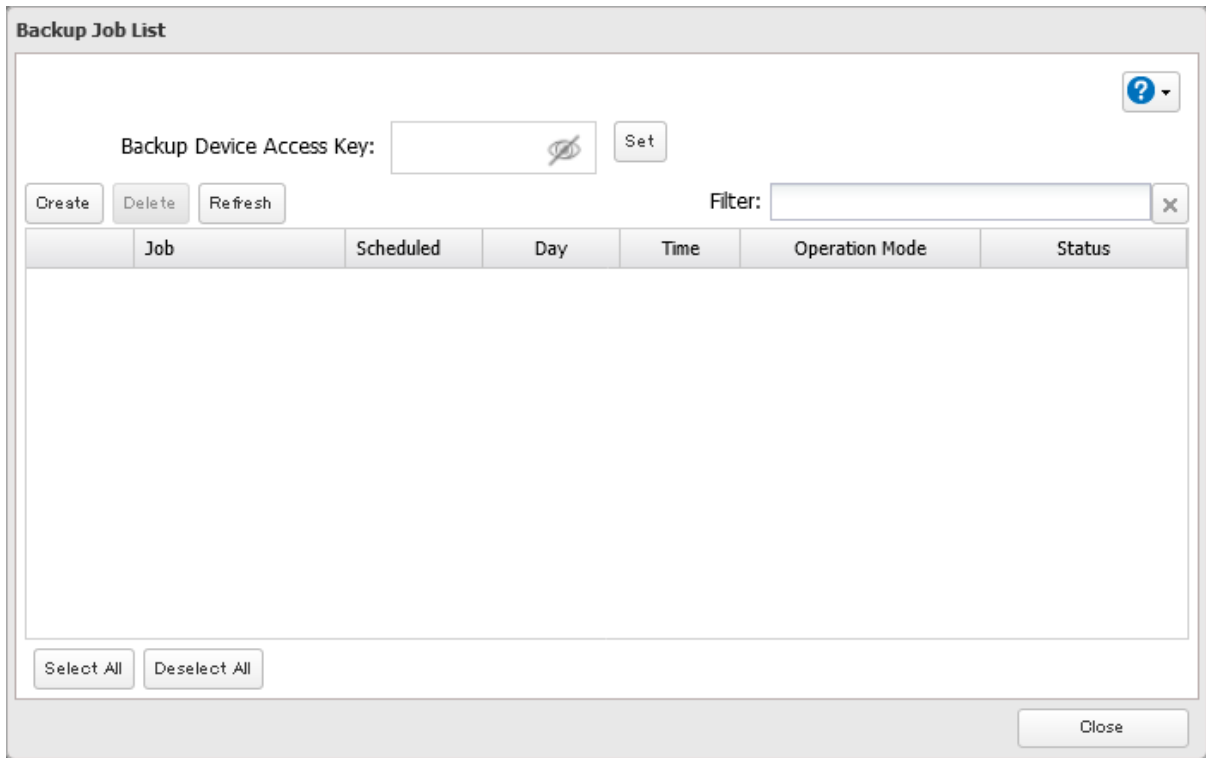

- 4 Enter the backup device access key and click *OK*.

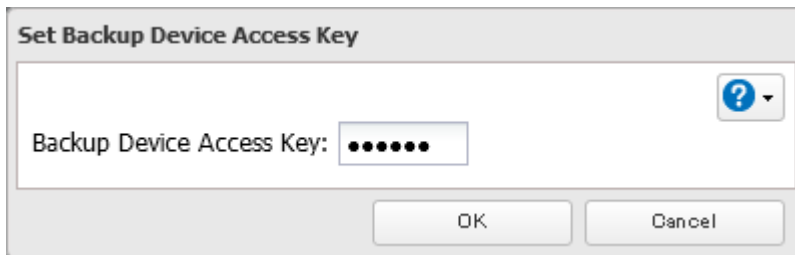

5 Click *Create*.

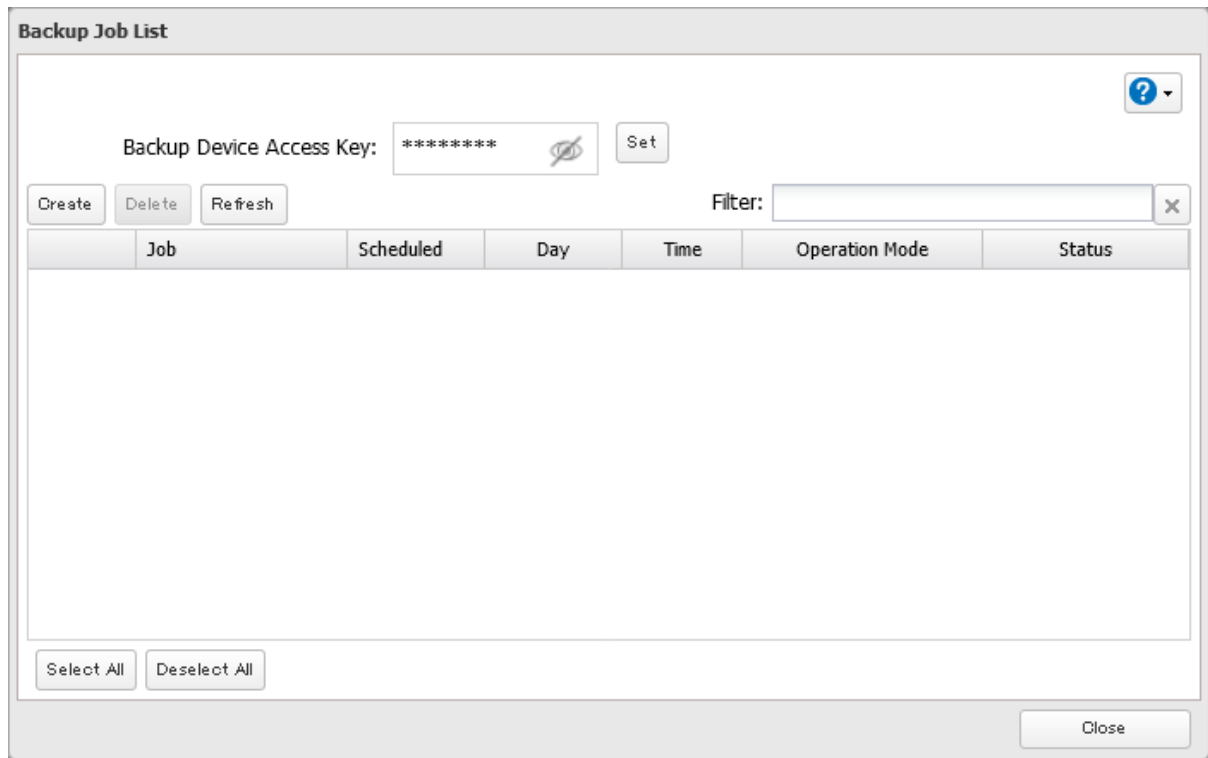

- 6 Select backup settings such as date and time to run, then select “iSCSI backup” for the “Operation Mode” drop-down list.

The screenshot shows the "Backup Job Settings" dialog box. At the top right, there is a red asterisk and the word "Required" next to a help icon. The "Job Name" field is labeled with a red asterisk and contains the text "job01". The "Schedule" section has three dropdown menus: "Not scheduled", "Sunday", and "00", followed by a colon and another dropdown menu "00". The "Operation Mode" dropdown menu is set to "iSCSI backup". Below this, the "Versions" field is set to "10" with a small up/down arrow, and there is a checked checkbox for "Unlimited".

Under the "Options" section, there are several checkboxes:

- Create a subfolder for backup
- Create backup log file
- Save backup logs in the backup source folder
- Select the folder to save backup logs

A "Target Folder:" label is followed by a "Browse" button. Below these are more checkboxes:

- Encrypted data transfer
- Compress and transfer
- Ignore backup errors and continue backup job on schedule
- Do not back up recycle bin
- Overwrite unchanged files
- Inherit subfolders' access restrictions

A note at the bottom of the options section reads: "If you change subfolders' access restriction settings after the backup job has run, it may not be carried over to the backup destination." At the bottom right of the dialog are "OK" and "Cancel" buttons.

- 7 Read the message carefully and click *OK*.

- 8 Click *Add*.

- 9 Select the original backup destination as the backup source, then select an iSCSI file I/O volume as the backup destination.

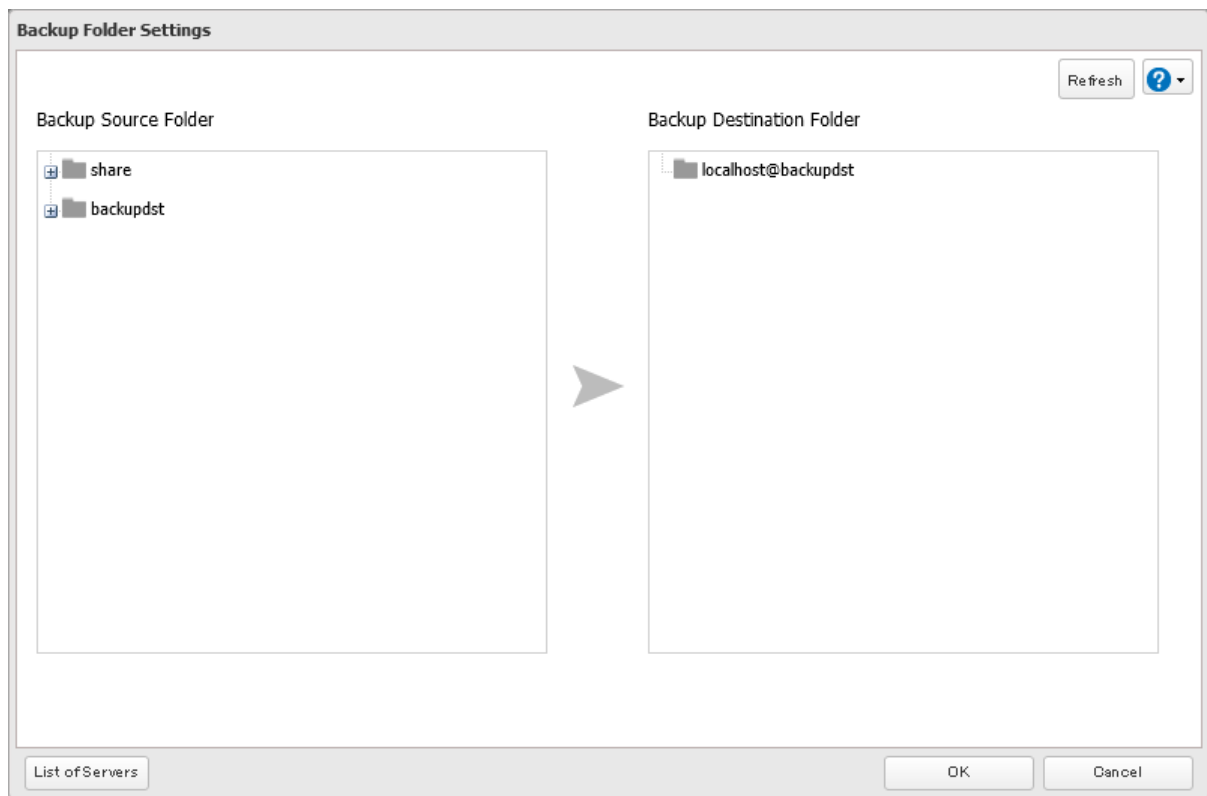

- 10 Click *OK*, then click *OK* again.

- 11 The process is complete once you close the confirmation window that appears. The backup job will be added to the backup jobs list.

The backup data will be restored on the backup destination after the backup job has run. If the backed up iSCSI volume is smaller than the backup source, and there is not enough space on the backup source to accommodate the backup data, the restore process will finish, but the backup source iSCSI volume will become corrupted.

Backup Logs for If Backup Fails

If backup fails, the I54 message will appear as a notification and the following backup error codes may be displayed in the "Status" field. Read the description and try the respective corrective actions for each error to resolve it.

Code	Description	Corrective Action	Log Example
Code 3	The backup destination USB drive could not be found.	Check that the backup destination USB drive is connected to the TeraStation properly.	rsync error: errors selecting input/output files, dirs (code 3) at main.c(634) [Receiver=3.1.0]
			Can't write to backup destination(target disk is broken?).

Code	Description	Corrective Action	Log Example
Code 5	The backup destination shared folder could not be found.	Check that the Ethernet cable is securely connected and that the hub or other devices on the network are turned on.	rsync error: error starting client-server protocol (code 5) at main.c(1504)
	Authentication failed.	Try adding the rsync-compatible NAS device from the server list again.	@ERROR: auth failed on module
	A registered user does not have permission to run.	Check the settings of the rsync-compatible NAS device.	@ERROR: permission denied
Code 10	The Ethernet cable was disconnected from the backup source TeraStation when the backup job started.	Reconnect the Ethernet cable.	rsync error: error in socket IO (code 10) at clientserver.c(128) [sender=3.1.0pre1]
	A backup destination doesn't support the subfolders' access restrictions.	Select another backup destination or remove the subfolders' access restrictions.	
Code 11	The drive capacity of the backup destination TeraStation became full.	Delete unnecessary files and folders.	rsync error: error in file IO (code 11) at receiver.c(389) [receiver=3.1.0]
	Files larger than 4 GB were backed up to the FAT32-formatted USB drive.	Reduce the file size to 4 GB or less, or change the file system to one other than FAT32. Refer to the "Adding an External Drive" section in chapter 5 for compatible file systems.	rsync: write failed on "filename": File too large (27)
	The snapshots limit has been exceeded.	Delete unnecessary snapshots from the backup source and destination folders.	-
Code 12	Could not communicate between backup source and destination TeraStations.	Check that the Ethernet cable is securely connected and that the hub or other devices on the network are turned on.	rsync error: error in rsync protocol data stream (code 12) at io.c(515)
	The settings of the TeraStation were changed while the backup job was running.	Do not change the settings while the backup job is running. If changed, the connection will temporarily terminate and the backup job will fail.	
Code 14	There was insufficient memory on the TeraStation so the backup job did not run.	Reduce the number of backup destination files or disable any other functions running at the same time.	ERROR: out of memory in flist_expand
Code 22			rsync error: error in IPC code (code 14) at main.c(655) [receiver=2.6.8]
			rsync: fork failed in do_recv: Cannot allocate memory (12)
			rsync error: error allocating core memory buffers (code 22) at util.c(120) [sender=2.6.8]

Code	Description	Corrective Action	Log Example
Code 20	The connection was disconnected while the backup job was running.	Do not change the settings while the backup job is running. If changed, the connection will temporarily terminate and the backup job will fail.	rsync error: received SIGINT, SIGTERM, or SIGHUP (code 20) at rsync.c(242)
Code 23	Invalid characters were used in the filename or folder name of the backup destinations.	Change the filename or folder name using compatible characters. Available characters are described in the “Adding a Shared Folder” section in chapter 4.	rsync error: some files could not be transferred (code 23) at main.c(702)
	The backup destination files were updated while the backup job was running.	Do not overwrite the backup destination files while the backup job is running. If updated, the backup destination files will not be backed up and the backup job will fail.	
	The TeraStation backed up the data to the FAT32-formatted USB drive, then the capitalization of letters in the filenames or folder names on the backup source TeraStation was changed.	Do not change the capitalization of letters in the filenames and folder names on the backup source TeraStation if the backup destination USB drive is formatted to FAT32. Linux on the TeraStation is case-sensitive but FAT isn't, so files or folders with names that are identical save for the capitalization will not be identified and treated as the same file or folder. To back up properly, using Btrfs, XFS, or ext3 is recommended.	
	A file system on the backup destination may be corrupted.	Run a drive check on the backup destination by referring to the “Checking Drives” section in chapter 5.	rsync recv_generator: failed to stat “filename”: Invalid argument (22)
Code 24	The backup destination files were updated while the backup job was running.	Do not overwrite the backup destination files while the backup job is running. If updated, the backup destination files will not be backed up and the backup job will fail.	rsync warning: some files vanished before they could be transferred (code 24) at main.c
Code 30	The Ethernet cable was disconnected from the backup source or destination TeraStations while the backup job was running.	Reconnect the Ethernet cable.	rsync error: timeout in data send/receive (code 30) at io.c(195) [sender=3.1.0]
B14	Insufficient TeraStation memory.	Restart the TeraStation and try again.	-

Code	Description	Corrective Action	Log Example
B101	The backup destination TeraStation does not exist.	Check that the backup destination TeraStation is turned on, the Ethernet cables are securely connected, and the hostname of the backup destination TeraStation has not been changed.	-
B102		Check that the backup destination folders on the backup destination TeraStation are on the shared folder list and the backup destination folders are configured for backup in Settings.	-
B103	The backup source folders on the backup source TeraStation do not exist.	Check that the backup source folders on the backup source TeraStation are on the shared folder list.	-
B104	The backup destination folders on the backup destination TeraStation do not exist.	Check that the backup destination folders on the backup destination TeraStation are on the shared folder list.	-
B105	The drives were not recognized.	Check that the drives are recognized properly in Settings. If you configure the "usbdisk" folders for the backup source or destinations, check whether these folders are on the shared folder list.	-
B106	The file systems of the USB drive are not supported.	Check that the USB drive is formatted to the compatible file systems. If you configure the management backup in the backup job, FAT format cannot be used for the backup destination.	-
B107	The device files such as "/dev/null" etc. do not exist.	Restart the TeraStation and try again.	-
B108	Credentials to access a shared folder on the rsync-compatible NAS device were not found.	Try adding the rsync-compatible NAS device from the server list again.	-

Replication

Replication copies all data from one shared folder to another shared folder on a different TeraStation. This is an easy way to set up a reliable data protection system in the event your main TeraStation fails. To configure replication, connect an Ethernet cable to the LAN port of each TeraStation and follow the procedure below. For best results, use static IP addresses.

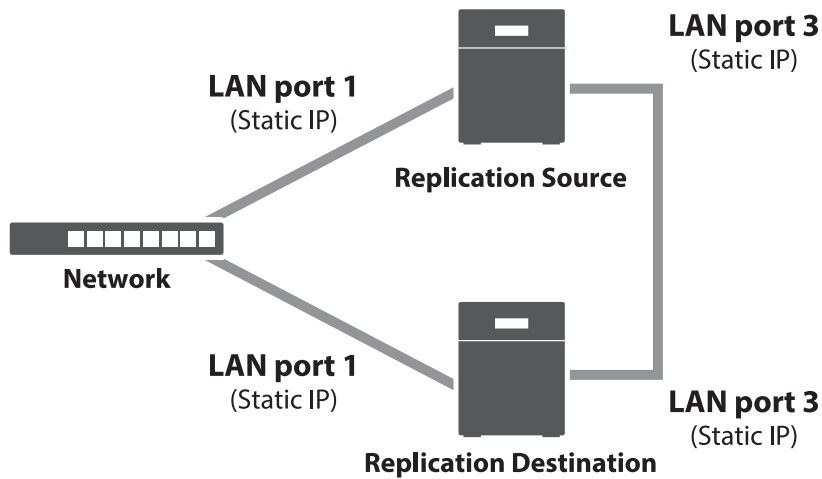

Note: Replication source data is copied to the replication destination folder with a differential overwrite. Any data not on the replication source will be overwritten.

The following describes what can be configured as replication sources and replication destinations.

Folders Available as Replication Sources

- Shared folder on the replication source TeraStation*

Folders Available as Replication Destinations

- Shared folder on the replication source TeraStation*, **
- Shared folder on another Buffalo NAS device**, ***

*Do not use a shared folder that is currently being used for Box Storage Sync.

**The folder should have the "Backup" checkbox selected under "LAN Protocol Support" on the shared folder settings.

***If the "Inherit subfolders' access restrictions" option is selected when creating a replication job, the device should be a Buffalo NAS device whose subfolders' access restrictions is available.

Preparing a Replication Destination

Configure a folder as a replication destination. Follow the procedure below to prepare a Buffalo NAS device as a replication destination.

Note: You cannot use the same replication destination folder for multiple replication source folders.

- 1 From Settings, click *File Sharing*.

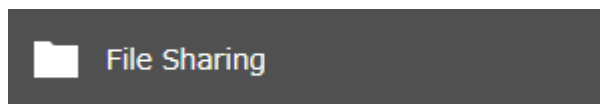

- 2 Click the settings icon (⚙️) to the right of "Folder Setup".



3 Choose the folder to be set as a replication destination.

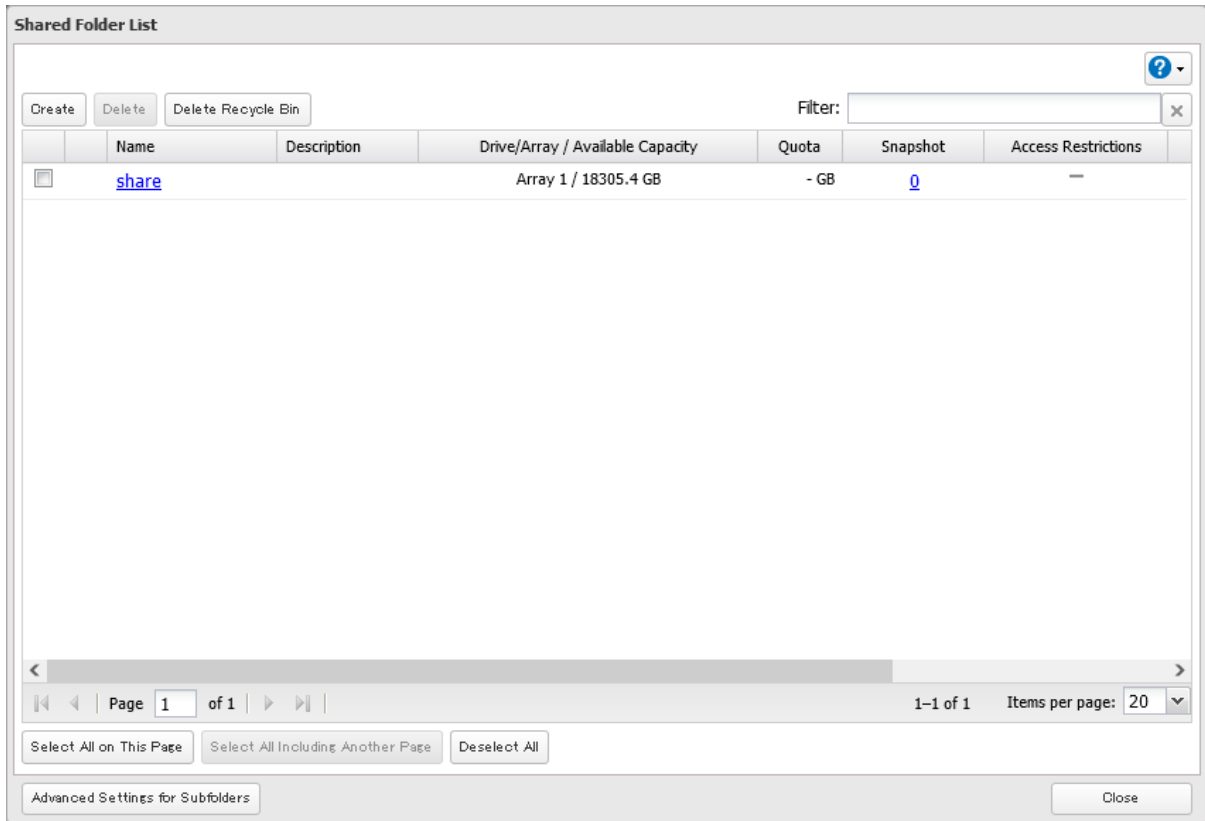

4 Under "LAN Protocol Support", select the "Backup" checkbox on the Basic tab.

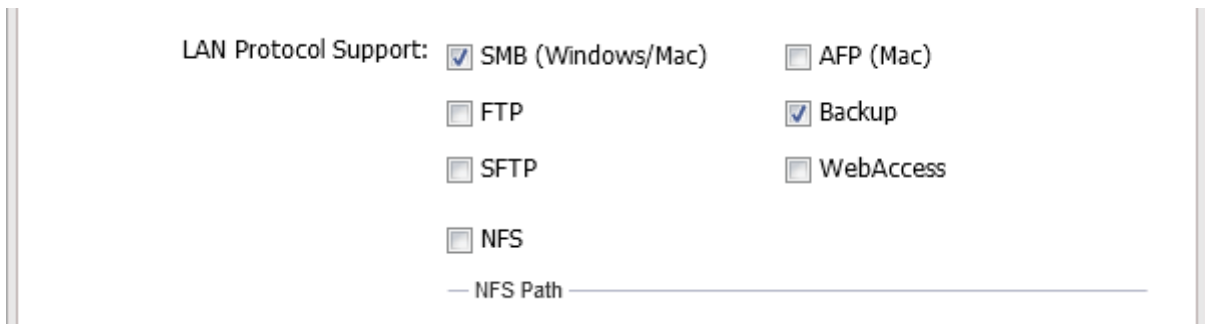

5 Click OK and proceed to the next step to create a backup device access key.

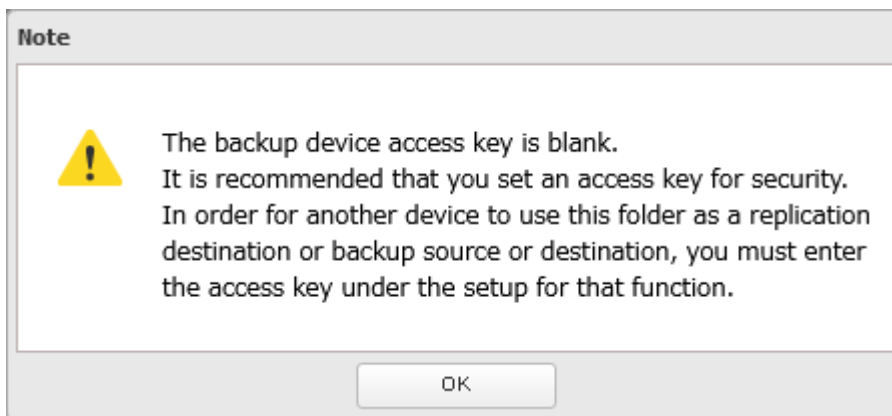

- 6** Enter the desired characters into the backup device access key field and click *OK*.

Backup Device Access Key:

Note: You may leave this field blank if you do not want a backup device access key, but for security reasons we highly recommend entering one for the shared folder. If a backup device access key is configured for the shared folder, that folder will not show up as the replication destination when configuring a replication job on another Buffalo NAS device unless it's entered. You may create multiple folders using different backup device access keys for backup and replication, but only one access key can be used on the TeraStation. Folders that are configured with a different access key cannot be used.

- 7** The process is complete once you close the confirmation window that appears.

Note: If you want to replicate to a Buffalo NAS device on another network, follow the procedure below to add the Buffalo NAS device so it can be used as a replication destination.

- (1) Create a new replication job by referring to the [“Configuring a Replication Job”](#) section below.
- (2) On the screen that allows you to select a shared folder, click *List of Servers*.
- (3) Click *Add*; select the “Add Buffalo NAS device” option, enter the IP address or hostname of the destination Buffalo NAS device, then click *OK*.
- (4) Click *Close*.
- (5) Click *Refresh* and make sure the desired Buffalo NAS device has been added to the list.

Configuring a Replication Job

- 1** From Settings on a replication source NAS device, click *Backup*.



- 2** Move the replication switch () to the position to enable replication.



- 3** Click the settings icon () to the right of “Replication”.



- 4** Click *Edit*.

- 5** If you had configured a backup device access key for the replication destination folder, click *Set*. If you hadn't, skip to step 7.

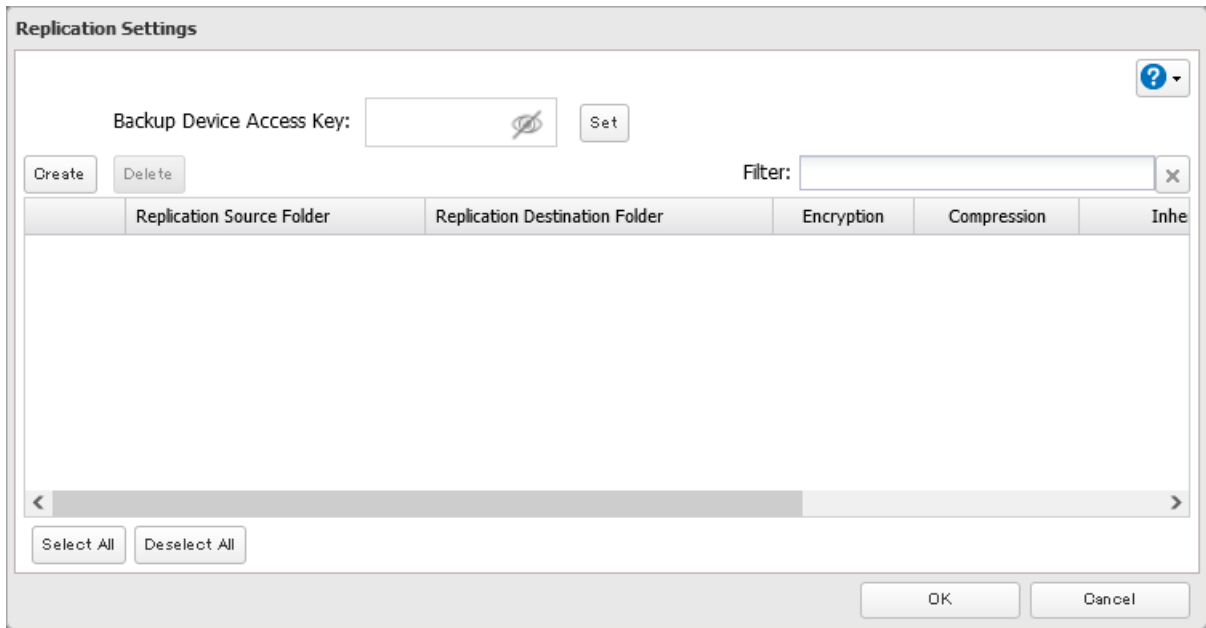

- 6** Enter the backup device access key and click *OK*.

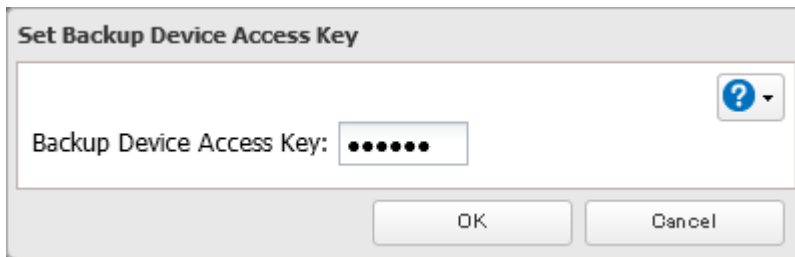

- 7** Click *Create*.

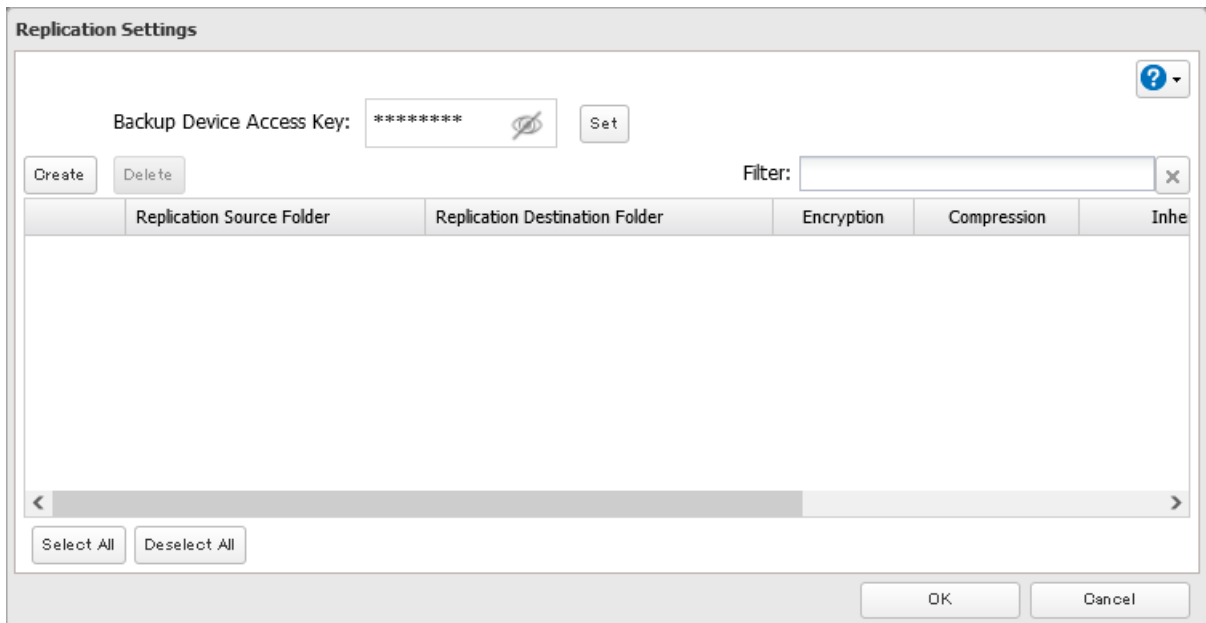

8 Select the shared folders that will be the replication source and destination.

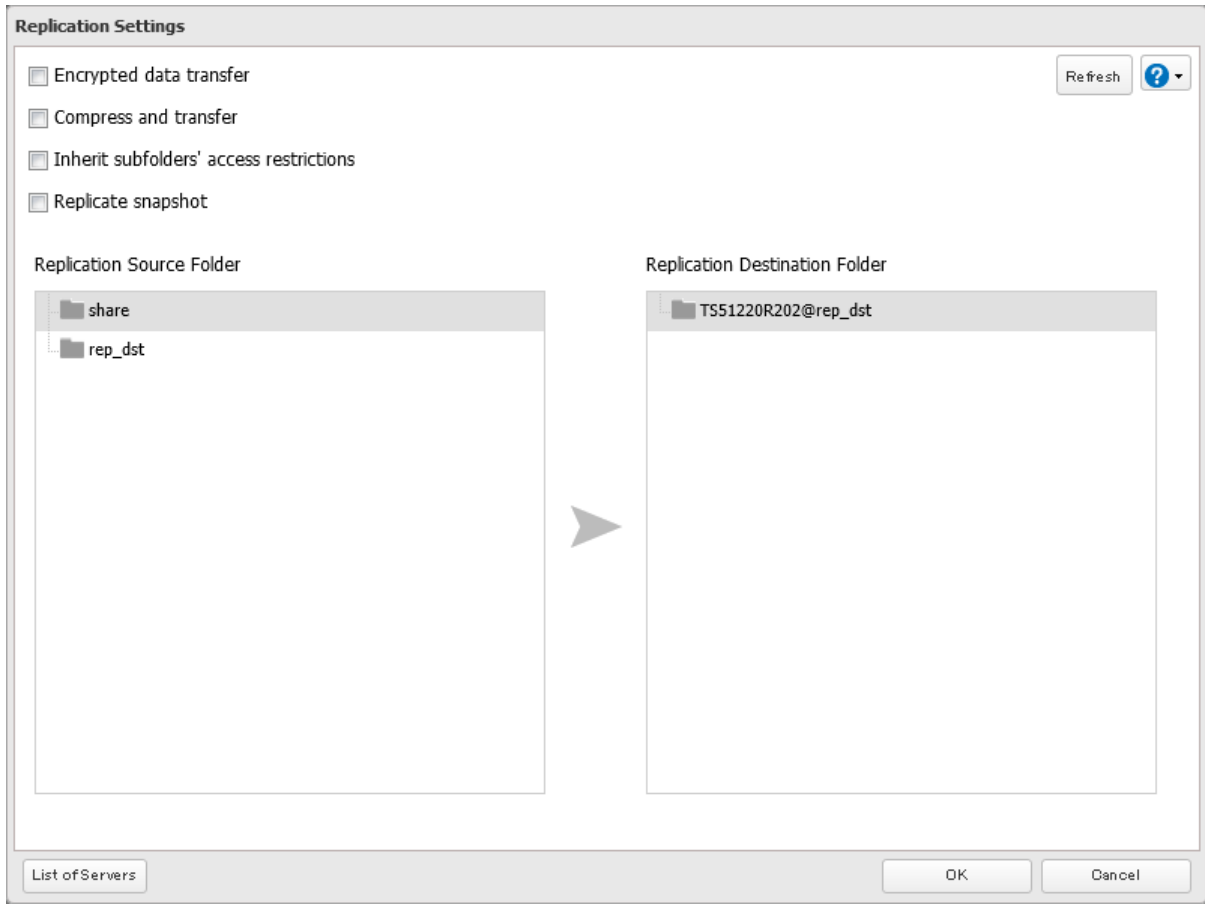

9 Click *OK*, then *OK* again.

10 Read the message carefully and click *Yes*.

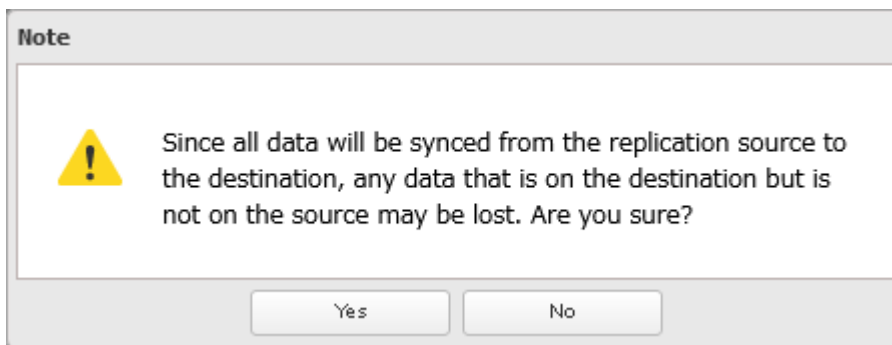

11 The process is complete once you close the confirmation window that appears.

Notes:

- During setup, you may choose to encrypt and/or compress replication data. Encrypted data will be transferred securely on the network. Compressed data will ease network loading and is recommended for slow or heavily loaded network connections. Enabling either will increase the CPU load on the source TeraStation so that the transfer speed will become slower, and replication time will be slower than if they are disabled. Encrypted or compressed data will be decrypted or decompressed on the destination TeraStation.
- A maximum of 64 shared folders can be configured for replication.
- Don't use the same TeraStation for both failover and replication, or replication and Time Machine.
- Don't configure replication from one source folder to multiple destination folders.

- If a network problem causes a replication error, unsynced data may be shown as “0” even though replication is incomplete. Click *Resync* to recover from the replication error. All files from the source folder will be copied to the destination folder.
- You can specify the LAN port to use for replication such as “(LAN3)”. If connecting to the same network using two or more LAN ports, configure each LAN port with a different network segment.
- If you also want to replicate the subfolder’s attributes (such as hidden files and read/write status) to the replication destination, select the “Inherit subfolders’ access restrictions” option for replication options.
- If you directly connect this TeraStation’s LAN port and another TeraStation’s 1GbE LAN port using an Ethernet cable, shared folders on the other TeraStation will not be displayed as replication targets. In such a case, change the LAN port to one other than 1GbE or use a smart switch.

This behavior will affect the following target TeraStation models:

- TS5010 series (TS5210DN, TS5410DN, TS5410RN, TS5810DN, TS51210RH TeraStation models)
- TS3020 series (TS3220DN, TS3420DN, TS3420RN TeraStation models)
- TS3010 series (TS3210DN, TS3410DN, TS3410RN TeraStation models)

Synchronizing Between Source and Destination TeraStations Periodically

Replication will immediately copy files that were saved via SMB connections to the replication destination. To copy files saved via file sharing protocols other than SMB (such as AFP or FTP) to the replication destination, configure “Periodic Sync” in Settings. Follow the procedure below to configure periodic sync.

Please note that if periodic sync is enabled, files saved via SMB connections while the periodic sync process is running will not be copied immediately. Instead, they will be copied during the next periodic sync process.

- 1 From Settings, click *Backup*.



- 2 Click the settings icon () to the right of “Replication”.



- 3 Click *Periodic Sync*.

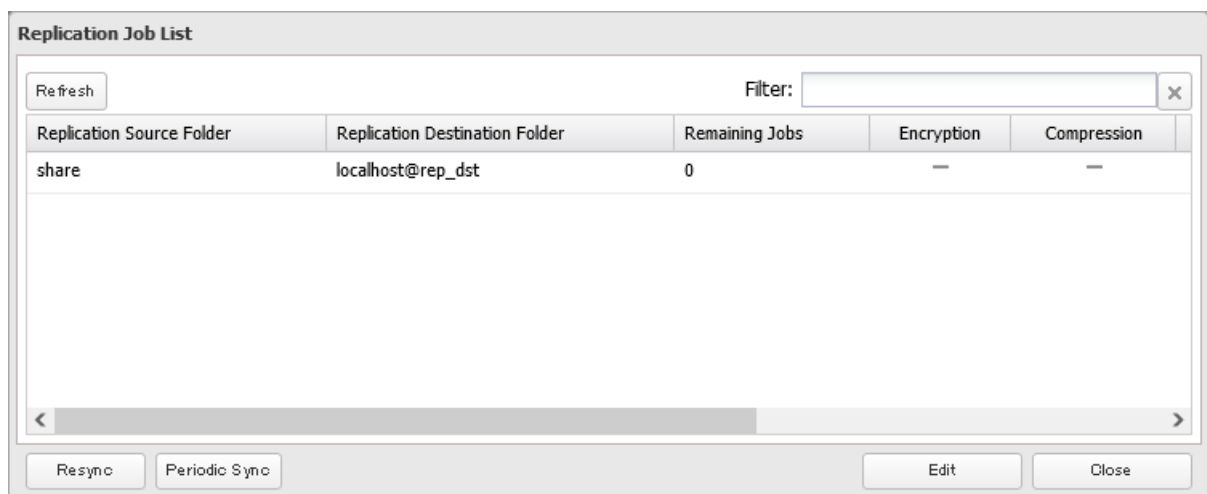

- 4** Select “Daily” or “Weekly” from the “Schedule” drop-down list. If “Daily” is selected, configure the sync period. If “Weekly” is selected, specify the weekdays and the sync period.

Periodic Sync Settings

Schedule:

Sunday Monday Tuesday Wednesday Thursday Friday Saturday

Sync Period: 00 : 00 Once every hour

OK Cancel

- 5** Click *OK*. The process is complete once you close the confirmation window that appears.

Failover

With failover, two TeraStations are connected to the network for redundancy, with one being the main TeraStation and the other being the backup TeraStation. If an issue renders the main TeraStation inaccessible, operation automatically switches to the backup TeraStation.

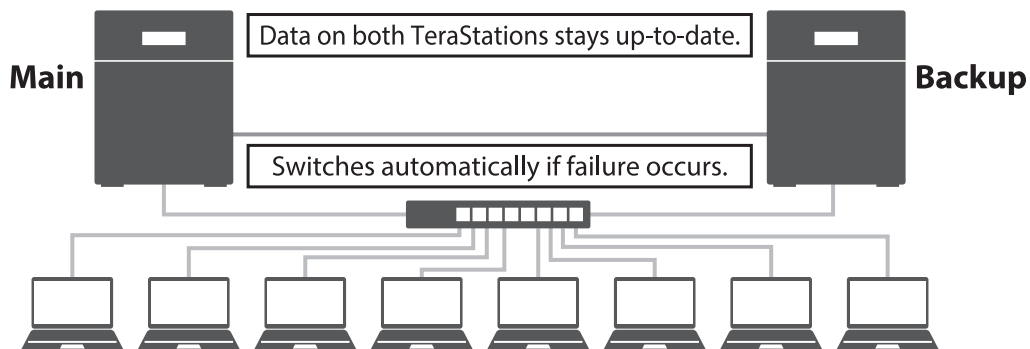

Failover will activate if any of the following occurs:

- **The backup TeraStation cannot detect the main TeraStation within a specified time**
If the backup TeraStation has not received a packet from the main TeraStation within a specified time, the backup TeraStation considers the main TeraStation to have failed. By default, it will try five times and wait 60 seconds. If this is triggered by accident, reconfigure failover from the main TeraStation.
- **Errors**
Failover will occur if any of the following errors occur:
E12 (cooling failure), E14 (cannot mount RAID array), E16* (drive not found), E22* (cannot mount drive), E30* (drive failure)

*This triggers when the drive is configured in JBOD.

Before Configuring Failover

Drive Bays

To use or configure failover, each adjacent drive bay of the TeraStation must be populated in sequential order, beginning with drive bay 1, with no empty bays or hot spares before the last populated drive bay.

LAN Ports

Use the same LAN ports for transferring data and configure both TeraStations with static IP addresses for the purposes of failover.

Using the Same LAN Port for Both File Sharing and Failover

Using this setup, if the main TeraStation fails, the backup TeraStation will replace it completely. The backup TeraStation will be updated over normal network traffic.

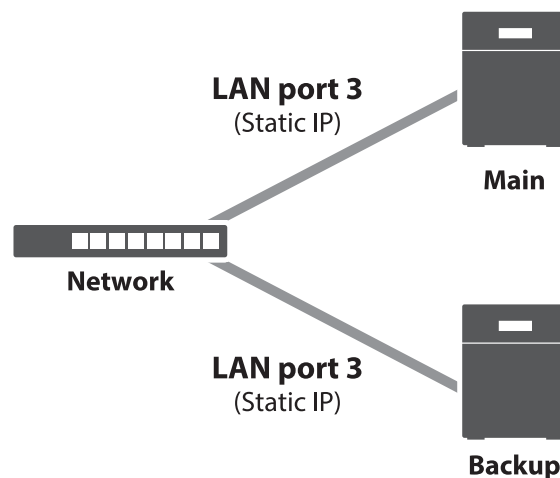

Using Different LAN Ports Between File Sharing and Failover

With this setup, the backup TeraStation and main TeraStation are connected by a second Ethernet cable connecting their LAN port 3. Updating is done over this dedicated network path, so updates are quicker and don't interfere with normal network traffic.

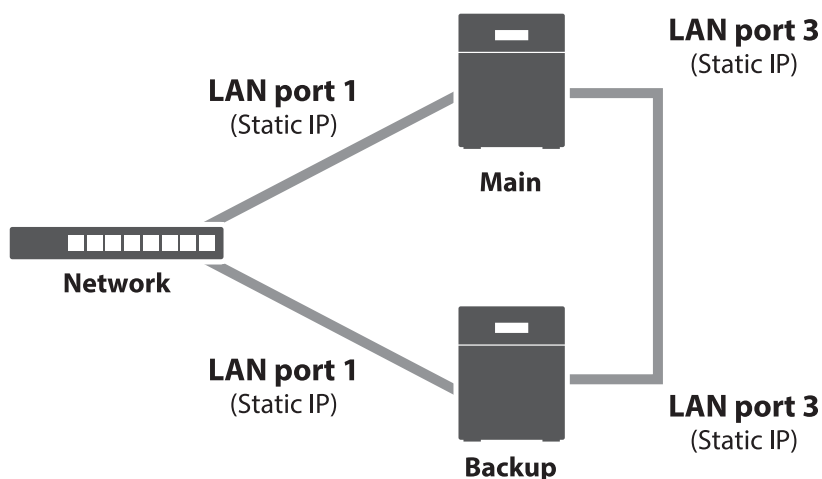

Active Directory

If you want to use both failover and Active Directory, configure Active Directory on the main TeraStation before configuring failover.

SNMPv3

If you want to use both failover and SNMP, and are using SNMPv3, configure SNMP on both the main and backup TeraStations before configuring failover.

UPS

If you want to use both failover and UPS sync, configure UPS sync on both the main and backup TeraStations before configuring failover.

Usage Restrictions

Functional Restrictions

Failover is not available when any of the following functions are enabled:

Replication, sleep mode, LVM, iSCSI, port trunking, Amazon S3-Compatible Storage, Box Storage Sync, Dropbox Sync, Microsoft Azure Storage Sync, Microsoft OneDrive Sync

Failover is not available when any of the following settings remain or have been configured:

Replication jobs, encrypted drive volume, Amazon S3 jobs, hot spare, access restrictions by Active Directory domain*, multiple active LAN ports connecting to the same network

*As described in the [“Before Configuring Failover”](#) section above, Active Directory can be used if the main TeraStation has joined the AD domain environment before configuring failover.

Setting Restrictions

The following operations will not be available while failover is configured:

Initializing settings, changing the RAID settings, formatting drives, configuring iSCSI volume, changing the backup TeraStation’s settings, turning the TeraStation on and off*, updating the firmware*

*The operations can be made available by temporarily putting the TeraStation into maintenance mode.

Non-Transferable Settings

The settings below are not copied from the main TeraStation to the backup TeraStation. Make a note of the original settings so that they can be configured manually if a failover error occurs.

IP address, hostname*, WebAccess, UPS sync, the backup job settings for either when shared folders not on the main TeraStation are specified or when a USB drive is set as the backup destination, USB drives’ shared folder settings, low drive space alerts, SNMPv3 settings, FIPS mode

*Since the hostname will not be transferred, use the virtual IP address configured for failover to access the shared folder after failover setup.

Using with UPS

If a main TeraStation shuts down due to UPS power failure while failover is configured, a backup TeraStation will enter into maintenance mode. When the power recovers, the backup TeraStation will automatically exit maintenance mode and return to normal operating mode.

Configuring Failover

- 1 From Settings for the main TeraStation, click *Backup*.



2 Click the settings icon () to the right of "Failover".



3 Click *Configure Failover*.

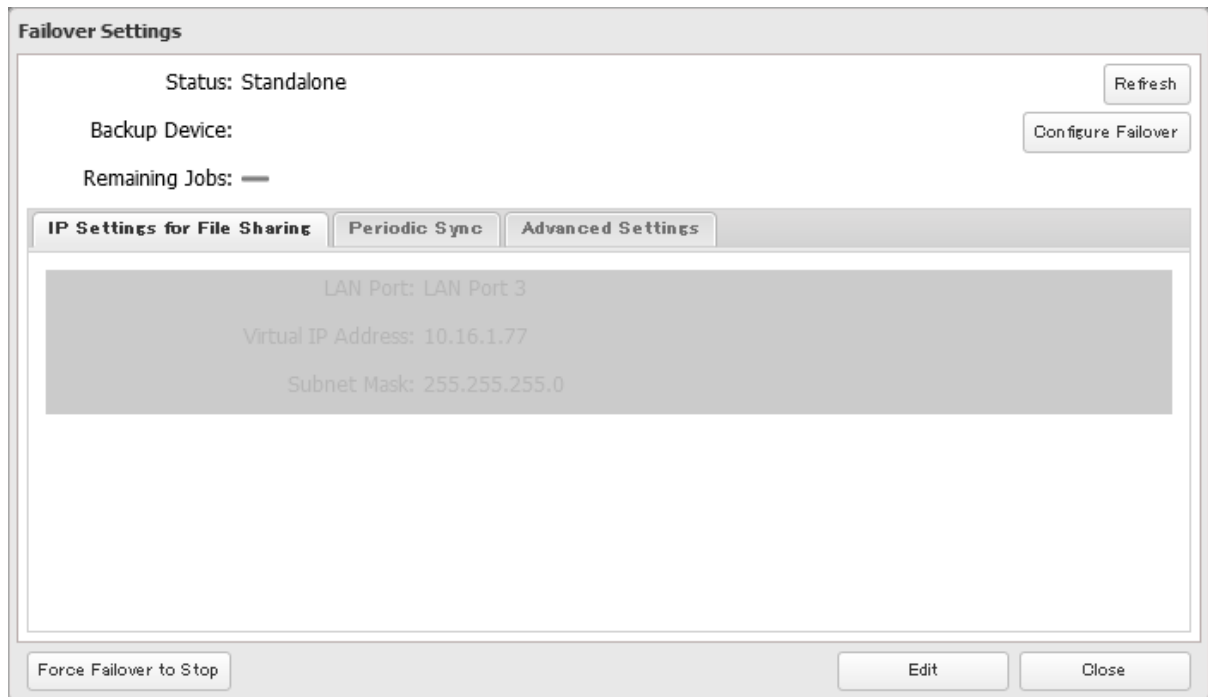

- 4** Select a TeraStation to be the failover backup device and enter its administrator username and password (by default, the username is “admin” and the password is “password”).

Failover Settings *Required ?

Backup Device Settings: Backup Device: TS71210R000

Administrator Username *: admin

Administrator Password *: ●●●●●●

IP Settings for File Sharing: LAN Port: (LAN2) 19.16.200.13

Virtual IP Address *: 19.16.200.105

Subnet Mask: 255.255.255.0

Backup LAN Port: (LAN2) 19.16.200.13

Snapshot: Copy Do not copy

Access Restrictions for Subfolders: Inherit Do not inherit

Use TeraStations of the same model and storage capacity for the main and backup units. Set the MTU size to 1,500 bytes for both units.

Continue Close

- 5** Select the LAN port to be used for sharing files and enter a virtual IP address. The LAN port you have selected here will also be used for pinging. If you select the same LAN port as the backup LAN port, the backup TeraStation will replace the main TeraStation even if just a network error occurs.

About virtual IP addresses: A virtual IP address is an IP address that will be used for file sharing while failover is configured. By assigning a different IP address from the one to be assigned to the LAN port, you can access the TeraStation for sharing files, as well as open Settings using the virtual IP address. This IP address will be inherited to the backup TeraStation when failover occurs, so you can access the backup TeraStation even if you don’t know the backup TeraStation’s static IP address.

Configure an unused IP address for the virtual IP; make sure it uses the same segment as the main and backup TeraStations.

- 6** Select the LAN port to be used for transferring data via failover.
- 7** Configure whether or not to inherit the settings of subfolders’ access restrictions to the backup TeraStation, then click *Continue*.

If you also want to copy the subfolder’s attributes (such as hidden files and read/write status) to the backup TeraStation, select “Inherit”.

- 8** If the admin username and password is correct, the **I51** message will appear as a notification for both main and backup TeraStations, and the backup TeraStation will beep. Press and hold down the function button on the backup TeraStation to accept the settings from the main TeraStation. When you press the function button, the backup TeraStation will stop beeping.

- 9 Press the function button. When you press the function button, the TeraStation will beep once. Press and hold down the button until the backup TeraStation beeps again.
- 10 Initialization on the main and backup TeraStations will begin. Wait until the **I51** message disappears.
- 11 Reload the page to refresh the displayed items.
- 12 From Settings, click *Backup*.



- 13 The process is complete when "Normal (main device)" is displayed for "Failover". If it shows "Standalone" still, try reconfiguring failover from the first step.



Notes:

- Only use identical model and capacity TeraStations for failover. If the capacity of the main TeraStation is larger than that of the backup TeraStation, an **I33** replication error will occur.
- All drive bays of a TeraStation should be occupied if it will be used for failover. Failover will not work if a drive is missing from any bay.
- If replication is configured for more than one folder, initialize the TeraStation before configuring failover.
- The main TeraStation cannot be used as the backup location for Time Machine.
- Do not use the same TeraStation for both failover and replication, or failover and Time Machine.
- If email notification is enabled and failover occurs, navigate to *Management > Email Notification > Edit* in the main TeraStation's Settings and click *OK*.
- MTU size settings for main and backup TeraStations should be 1,500 bytes. To change the MTU size, refer to the "[Jumbo Frames](#)" section in chapter 10.
- Files whose filenames contain more than 80 alphanumeric characters will not be backed up.
- If the **I33** message appears as a notification, navigate to *Backup > Failover > Configure Failover* and click *Resync*.
- The RAID array on the backup TeraStation may be reconfigured and resynchronized as part of the failover configuration process. This is expected behavior and not an error.
- Failover cannot be configured while the TeraStation cannot communicate with the proxy server. If the TeraStation is located on a network that cannot communicate with the proxy server, disable the proxy server settings before configuring failover. After configuration finishes, enable the proxy server settings again.

Changing Settings While Failover Is Configured

Before changing any TeraStation settings while failover is configured, make sure the TeraStation has entered into maintenance mode. If you change any settings without entering into maintenance mode, the **I49** message may appear.

For the procedure to enter maintenance mode, refer to the "[Maintenance Mode](#)" section below.

Maintenance Mode

The TeraStation has certain settings that cannot be configured or modified while other existing settings are in effect, such as failover. In such a case, putting the TeraStation into maintenance mode allows you to change certain TeraStation settings without affecting existing settings.

Follow the procedure below to make the TeraStation enter into maintenance mode.

1 From Settings for the main TeraStation, click *Backup*.



2 Click the settings icon () to the right of "Failover".



3 Click *Configure Failover*.

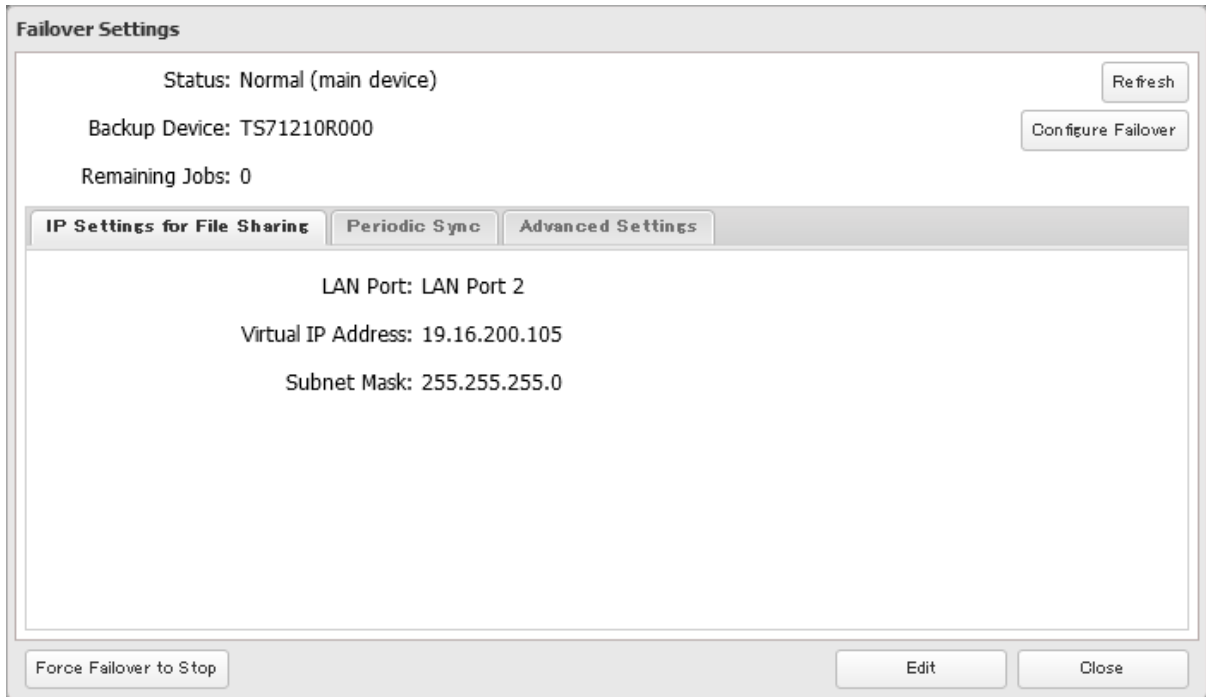

4 Click *Maintenance Mode*.

Failover Settings *Required 

Backup Device:	TS71210R000
Administrator Password:	*****
Snapshot:	Copy
Access Restrictions for Subfolders:	Inherit

Use TeraStations of the same model and storage capacity for the main and backup units. Set the MTU size to 1,500 bytes for both units.

Maintenance Mode
Resync
Force Failover to Stop
Stop Failover
Close

5 Read the message carefully and click *Yes*.

Note



The maintenance mode is for temporary use, such as change location or update firmware. When you're finished with maintenance, click 'Cancel Maintenance Mode' to go back to normal mode.

Yes
No

6 The process is complete once the TeraStation enters maintenance mode.

Once you are finished with changing settings in maintenance mode, make sure the TeraStation leaves maintenance mode. You can do this by either pressing and holding the function button, or by following the procedure below to exit maintenance mode from the main TeraStation's Settings.

1 From Settings for the main TeraStation, click *Backup*.



2 Click the settings icon () to the right of "Failover".



3 Click *Configure Failover*.

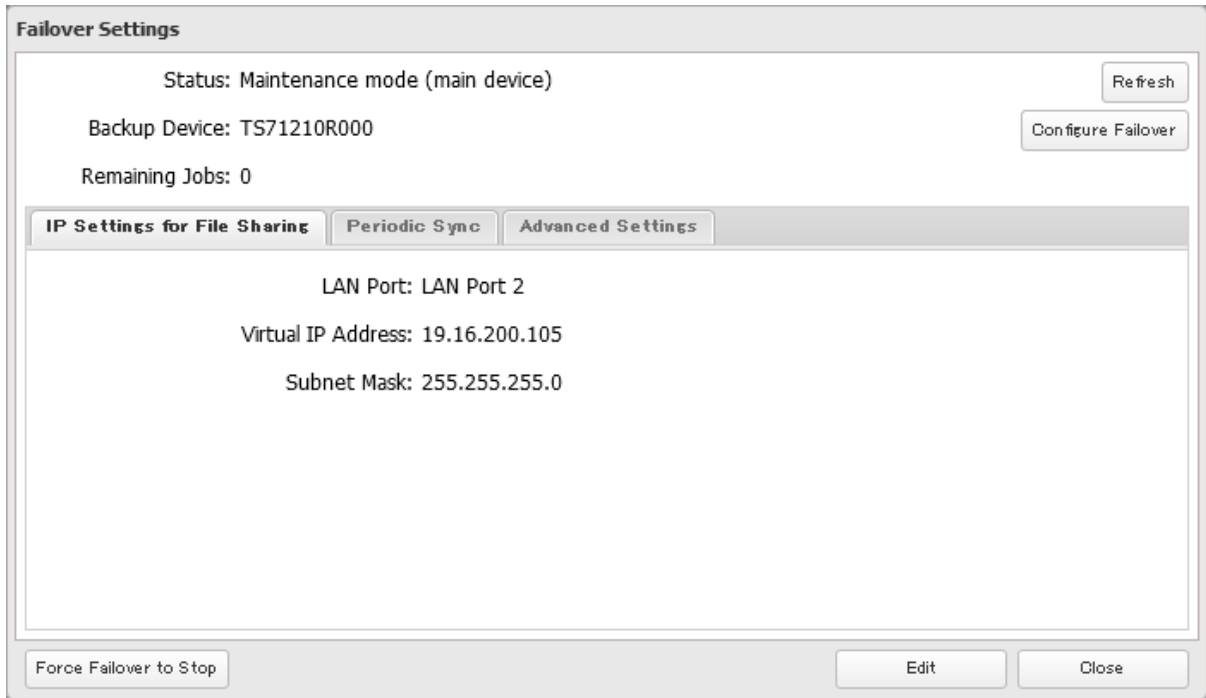

4 Click *Cancel Maintenance Mode*.

Failover Settings *Required ?

Backup Device: TS71210R000

Administrator Password: *****

Snapshot: Copy

Access Restrictions for Subfolders: Inherit

Use TeraStations of the same model and storage capacity for the main and backup units. Set the MTU size to 1,500 bytes for both units.

Cancel Maintenance Mode Resync Force Failover to Stop Close

5 The process is complete once you close the confirmation window that appears.

Note: To update the firmware while in maintenance mode, the main TeraStation can be updated from Settings, but the backup TeraStation cannot. Download the firmware updater from the [Buffalo website](#) for the backup TeraStation and try updating the firmware on it.

Synchronizing Between Main and Backup TeraStations Periodically

Failover will immediately copy files that were saved via SMB connections to the backup TeraStation. To copy files saved via file sharing protocols other than SMB (such as AFP or FTP) to the backup TeraStation, configure “Periodic Sync” in Settings. Follow the procedure below to configure periodic sync.

Please note that if periodic sync is enabled, files saved via SMB connections while the periodic sync process is running will not be copied immediately. Instead, they will be copied during the next periodic sync process.

1 From Settings for the main TeraStation, click *Backup*.



2 Click the settings icon (⚙) to the right of “Failover”.



3 Click the *Periodic Sync* tab, then click *Edit*.

Failover Settings

Status: Standalone Refresh

Backup Device: Configure Failover

Remaining Jobs: —

IP Settings for File Sharing **Periodic Sync** **Advanced Settings**

LAN Port: LAN Port 3
Virtual IP Address: 10.16.1.77
Subnet Mask: 255.255.255.0

Force Failover to Stop Edit Close

4 Select “Daily” or “Weekly” from the “Schedule” drop-down list and click *OK*. If “Daily” is selected, configure the sync period. If “Weekly” is selected, specify the weekdays and the sync period.

Failover Settings

Status: Standalone *Required ?

Backup Device: Configure Failover

IP Settings for File Sharing **Periodic Sync** **Advanced Settings**

Schedule: Daily

Sunday Monday Tuesday Wednesday Thursday Friday Saturday

Sync Period: 00 : 00

Once every hour

OK Cancel

5 The process is complete once you close the confirmation window that appears.

Switching to the Backup TeraStation Manually

If “Switch to backup unit manually” is selected on the *Advanced Settings* tab in the main TeraStation’s Settings, the backup TeraStation will not replace the main TeraStation if the main TeraStation fails. To manually replace the main TeraStation with the backup TeraStation, you can either:

- Log in to Settings for the backup TeraStation and click *Set as Main Unit*.

- Press the function button on the backup TeraStation. The TeraStation will beep once. Press and hold down the function button until the backup TeraStation beeps again.

Note: If the main TeraStation fails but all LAN port connections on the backup TeraStation remain active, you cannot replace the main TeraStation with the backup TeraStation from Settings. In such a case, use the function button instead.

Reconfiguring After Failover Occurs

When the backup TeraStation replaces the main TeraStation, the **I49** message may appear as a notification on the backup TeraStation. To configure failover again, follow the procedure below using a new TeraStation unit. The following procedure uses the example of a replaced backup TeraStation (“main TeraStation”) and the new TeraStation (“backup TeraStation”).

If you don’t want to configure failover with the new TeraStation, cancel the failover settings by following steps 1–5 below and restart both TeraStations. The **I49** message will disappear.

Note: The following procedure will also work if failover occurs unexpectedly.

1 After failover occurs, log in to Settings for the new main TeraStation.

If you have configured to synchronize with the UPS device connected to the failed TeraStation, the **E10** error will appear as a notification on the main TeraStation. In such a case, follow the procedure below to change the UPS settings on the new main TeraStation. If you hadn’t, skip to the next step.

- Disconnect the UPS cable from the failed TeraStation and connect it to the main TeraStation.
- Click *Management*.
- Click the settings icon () to the right of “Power Management”.
- Click *Edit* and select “Sync with UPS connected to this TeraStation”, then reconfigure the desired UPS settings.
- Click *OK*.

2 Click *Backup*.



3 Click the settings icon () to the right of “Failover”.



4 Click *Configure Failover*.

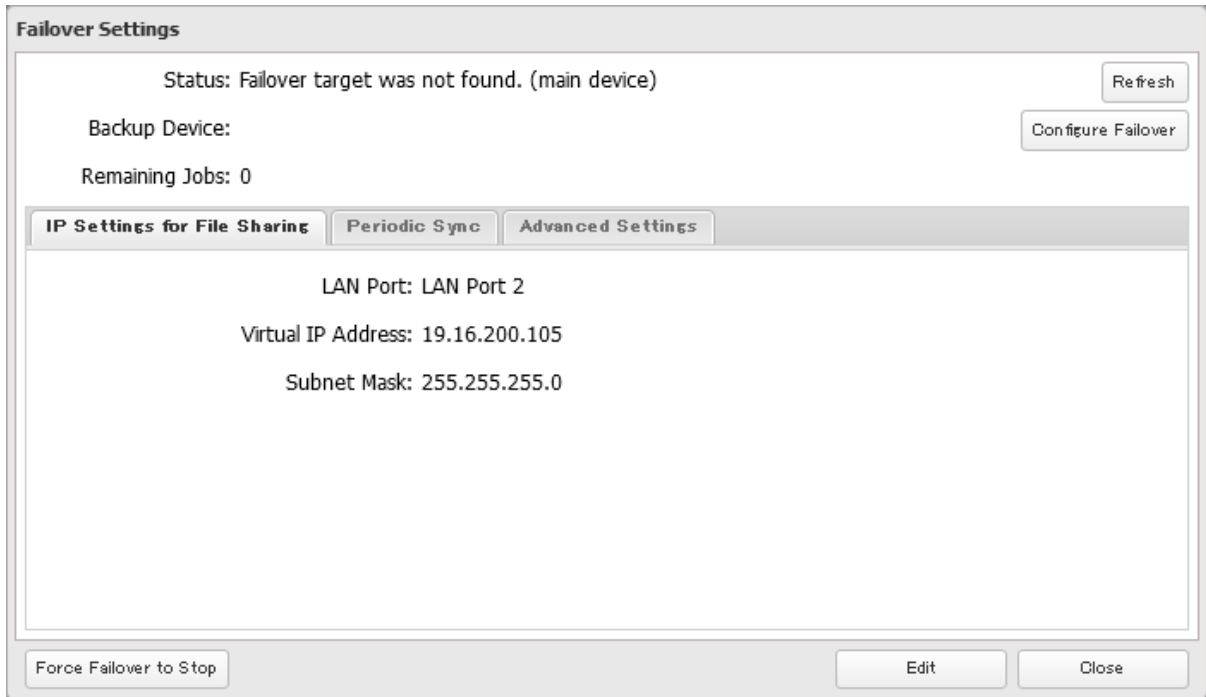

5 Click *Force Failover to Stop* to cancel the failover settings.

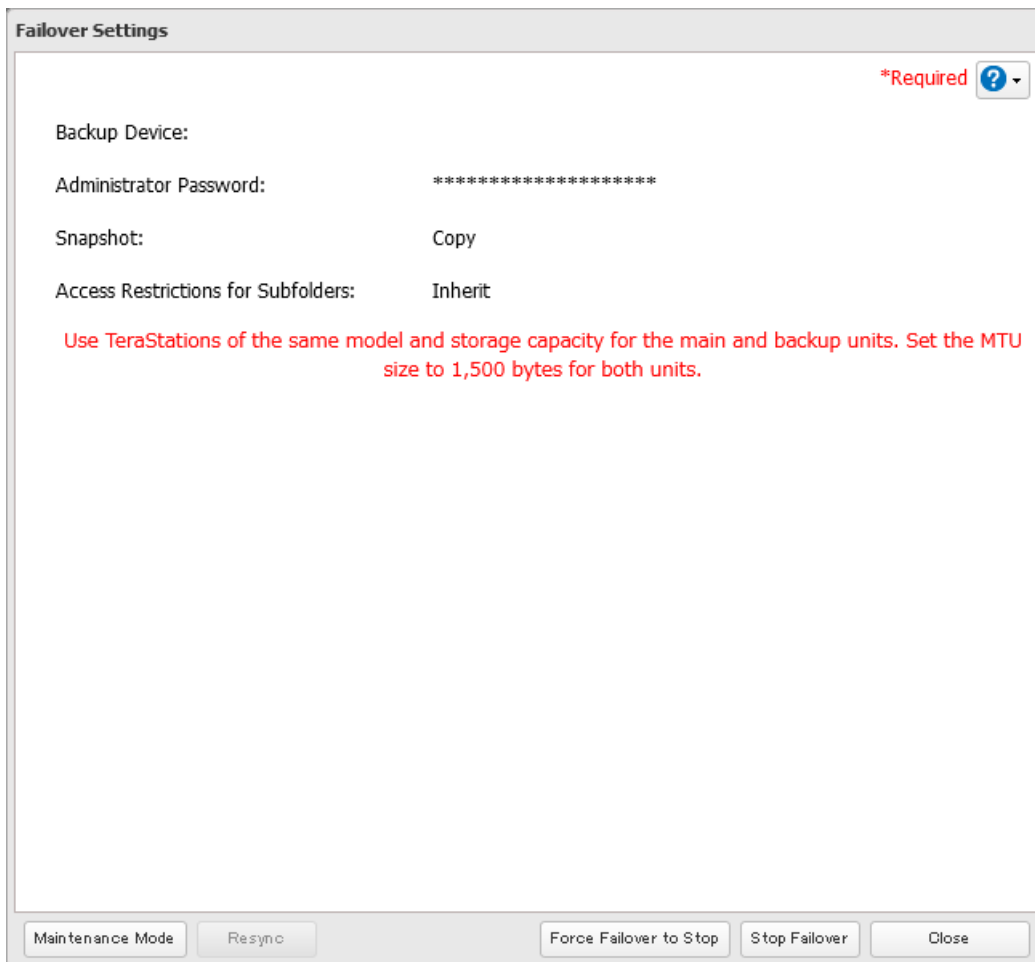

6 Shut down this main TeraStation.

- 7** Turn the backup TeraStation on.
- 8** Log in to Settings for the backup TeraStation, then rename the TeraStation's hostname and configure the IP address so that it has a new static IP address.
- 9** Power on the main TeraStation. To configure the UPS sync on the backup TeraStation, configure the settings here. Otherwise, skip to the next step.
To synchronize with the UPS device connected to the main TeraStation, follow the procedure below on the backup TeraStation.
 - a. Click *Management*.
 - b. Click the settings icon () to the right of "Power Management".
 - c. Click *Edit* and select "Sync with UPS connected to another Buffalo NAS device on the same network", then configure the main TeraStation as a sync source.
 - d. Click *OK*.
- 10** The process is complete once you reconfigure failover by referring to the ["Configuring Failover"](#) section above.

Stopping Failover

If you want to stop failover while both the main and backup TeraStations are working properly, follow the procedure below.

Stopping from the Main TeraStation

- 1** From Settings for the main TeraStation, click *Backup*.



- 2** Click the settings icon () to the right of "Failover".



3 Click *Configure Failover*.

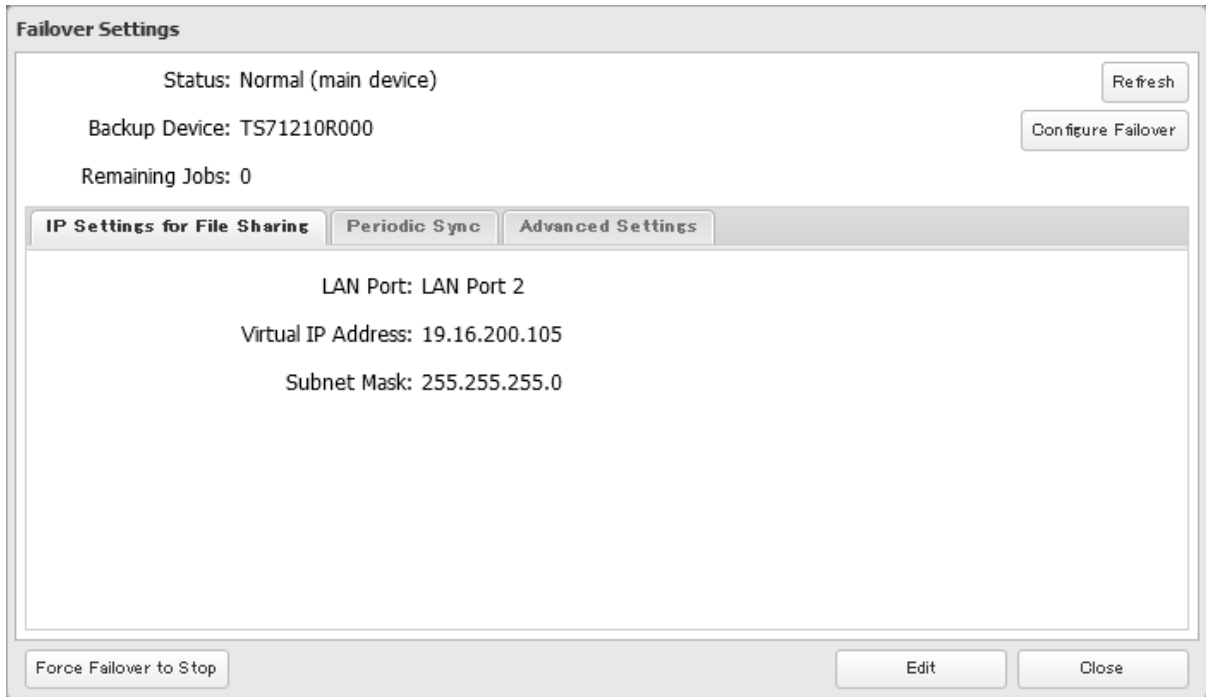

4 Click *Stop Failover*.

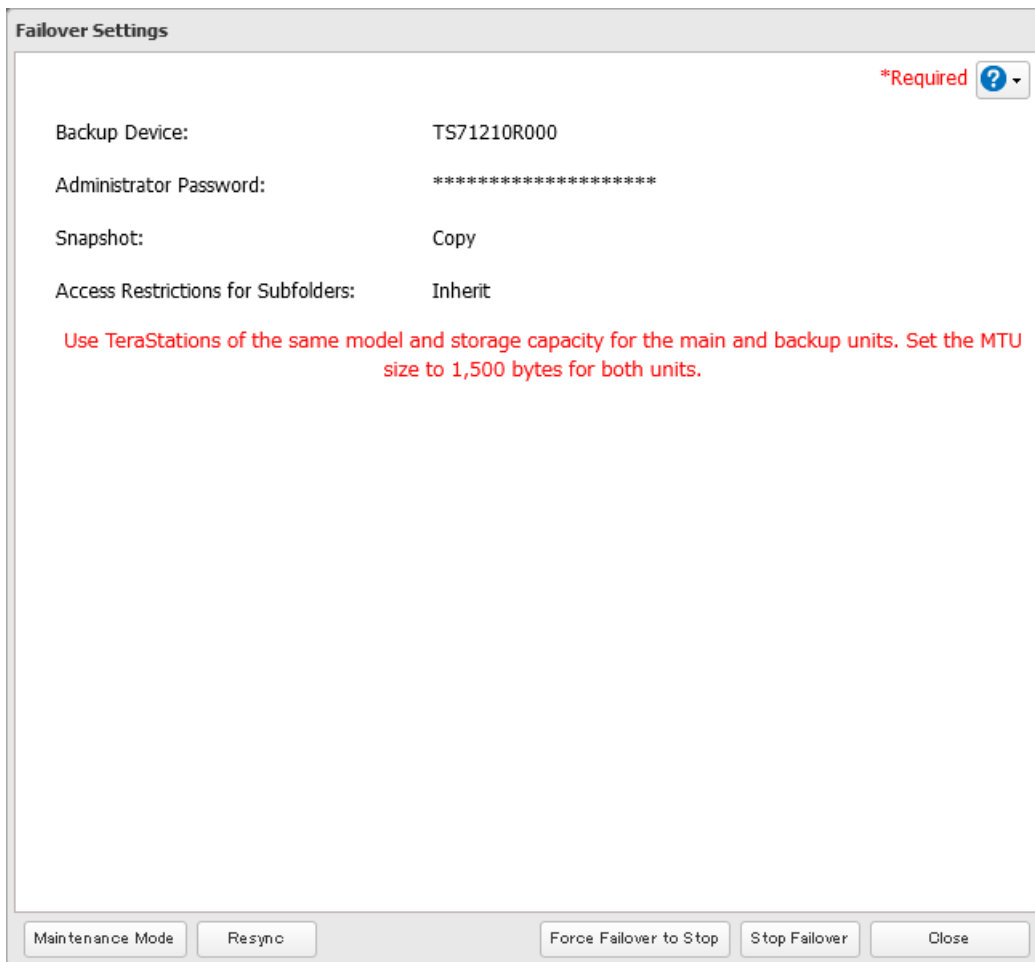

5 The process is complete once you close the confirmation window that appears.

Stopping from the Backup TeraStation

Log in to Settings for the backup TeraStation and click *Force Failover to Stop*.

Stopping Failover Forcibly

If failover hasn't been stopped by taking actions from both the main and backup TeraStations, navigate to *Backup > Failover > Configure Failover* in Settings for the main TeraStation and click *Force Failover to Stop* to restart both TeraStations. After the TeraStations are restarted, make sure that all settings such as IP address and files in the shared folders are unchanged.

When you forcibly stop failover, attributes of the shared folders on the backup TeraStation will become read-only. Change the attribute settings to the desired options if necessary.

Backing Up Your Mac with Time Machine

Time Machine is a backup program included with macOS. Configure your TeraStation as shown below to use Time Machine.

1. Configuring a Shared Folder as a Backup Destination

- 1 From Settings, click *Backup*.



- 2 Click the settings icon (⚙️) to the right of "Time Machine".



- 3 Click *Edit*, then *Browse*.

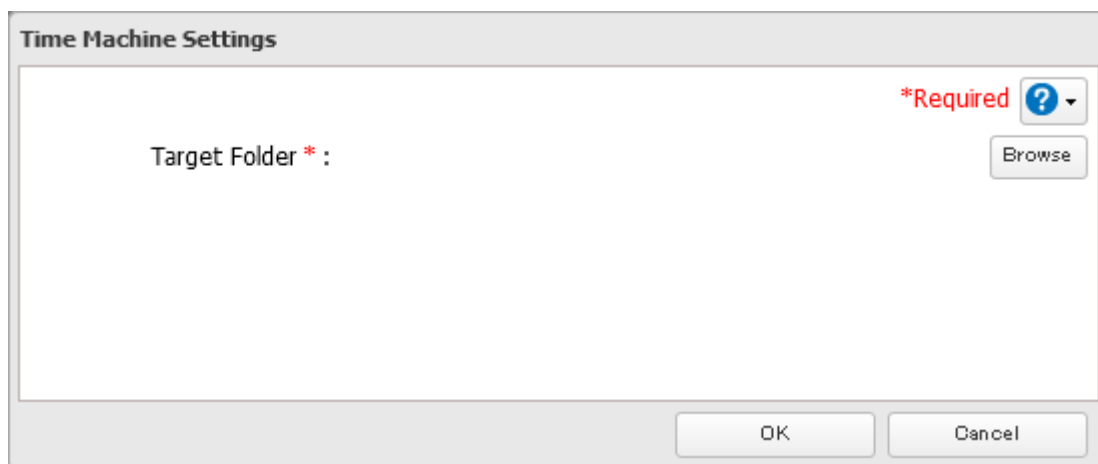

- 4 Select the shared folder and click *OK*.

5 Click *OK*, then click *OK* again.

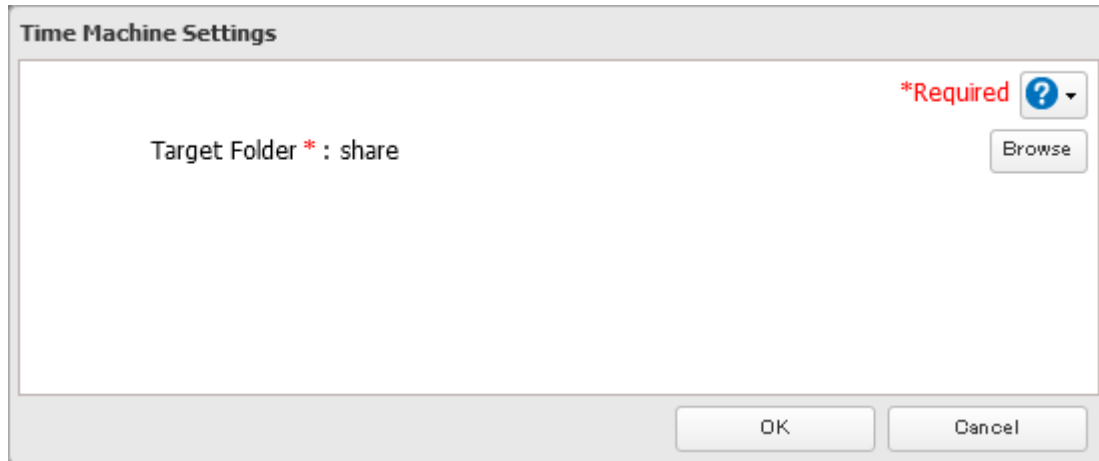

6 The process is complete when you move the Time Machine switch () to the  position to enable Time Machine.

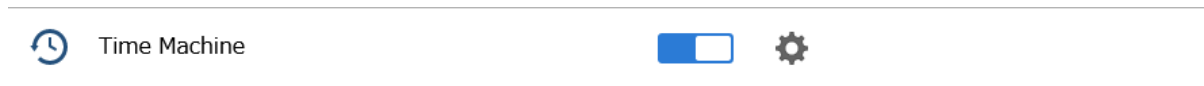

Note: We recommend adding a quota to limit the backup shared folder space that can be used for Time Machine. If you don't add a quota, Time Machine will continue to use all available space. To configure quotas, refer to the ["Quotas"](#) section in chapter 5.

2. Configuring Time Machine on macOS

This procedure uses macOS 13.0 as an example.

1 From the Apple menu, open *System Settings*.

2 Navigate to *General > Time Machine*.

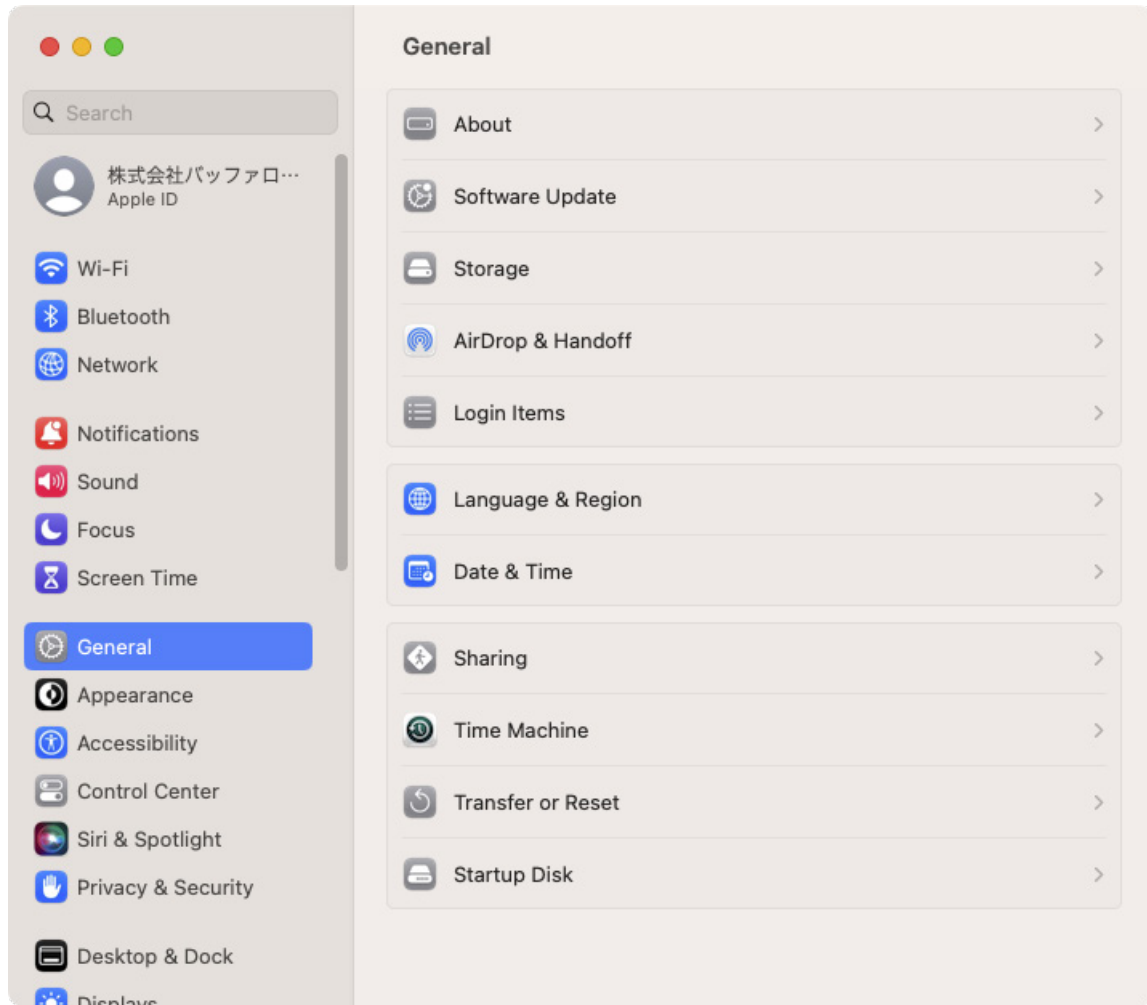

3 Click *Add Backup Disk*.

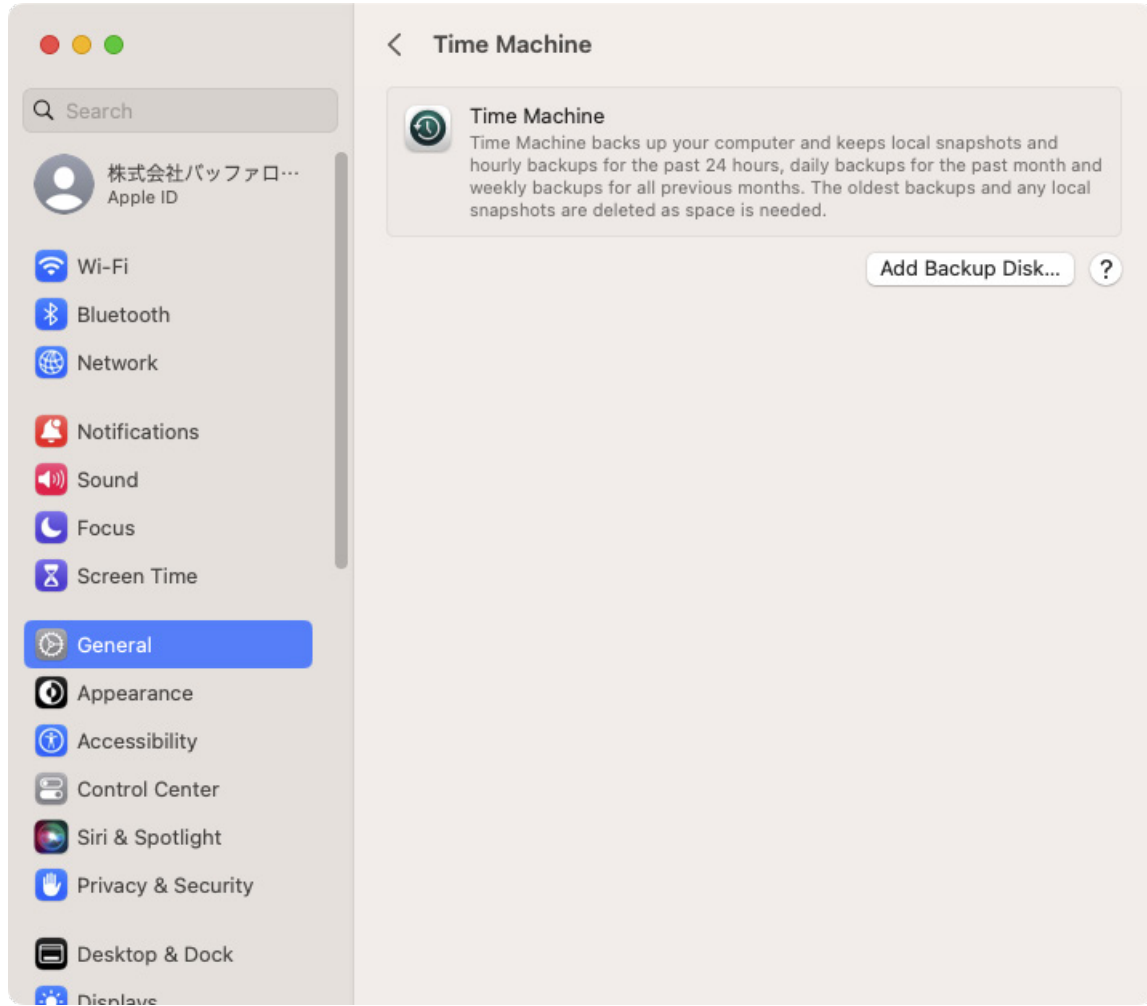

4 Select the shared folder, then click *Set Up Disk*.

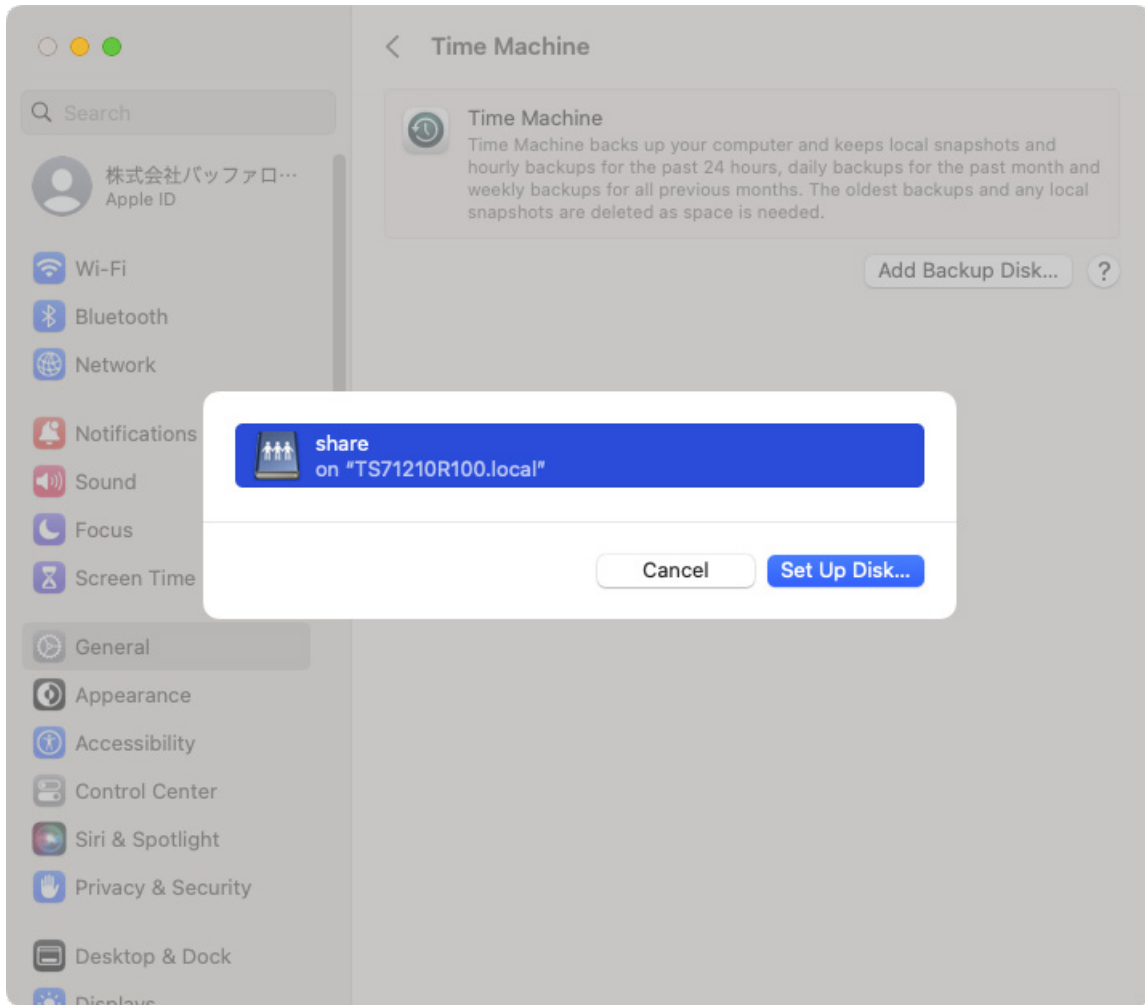

5 Click *Connect*.

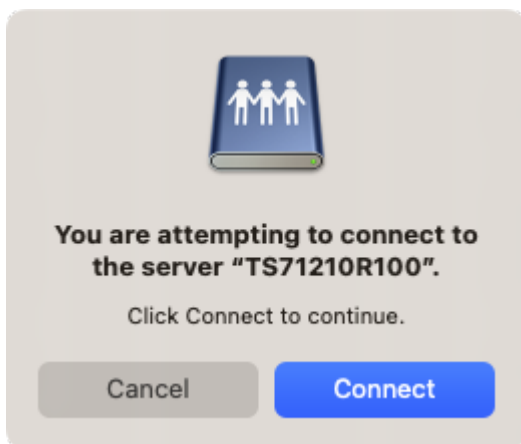

6 Enter a username and password to be used for accessing the shared folder and click *Connect*.

If access restrictions are not configured on the destination share, log in using the administrator account. The default username and password for the administrator account are “admin” and “password”. If access restrictions are configured, log in using an account with write privileges.

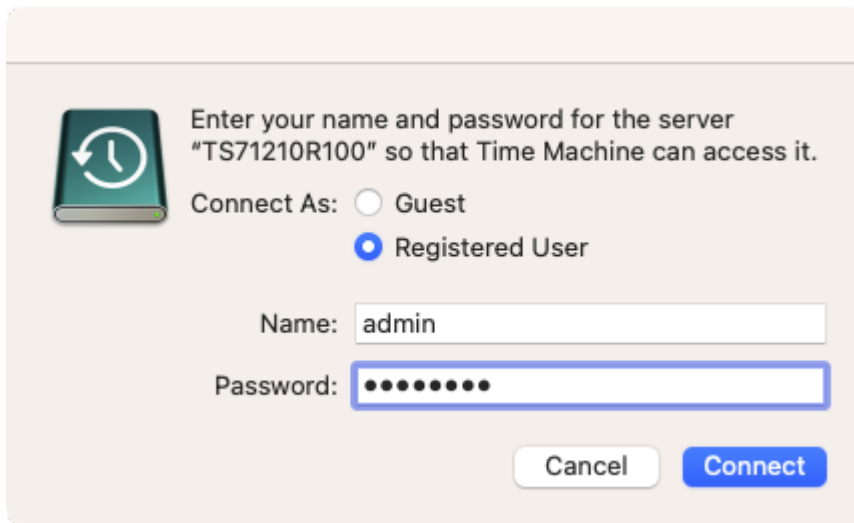

7 Select whether to encrypt the backup data and click *Done*.

If enabling encryption, enter the password for backup twice.

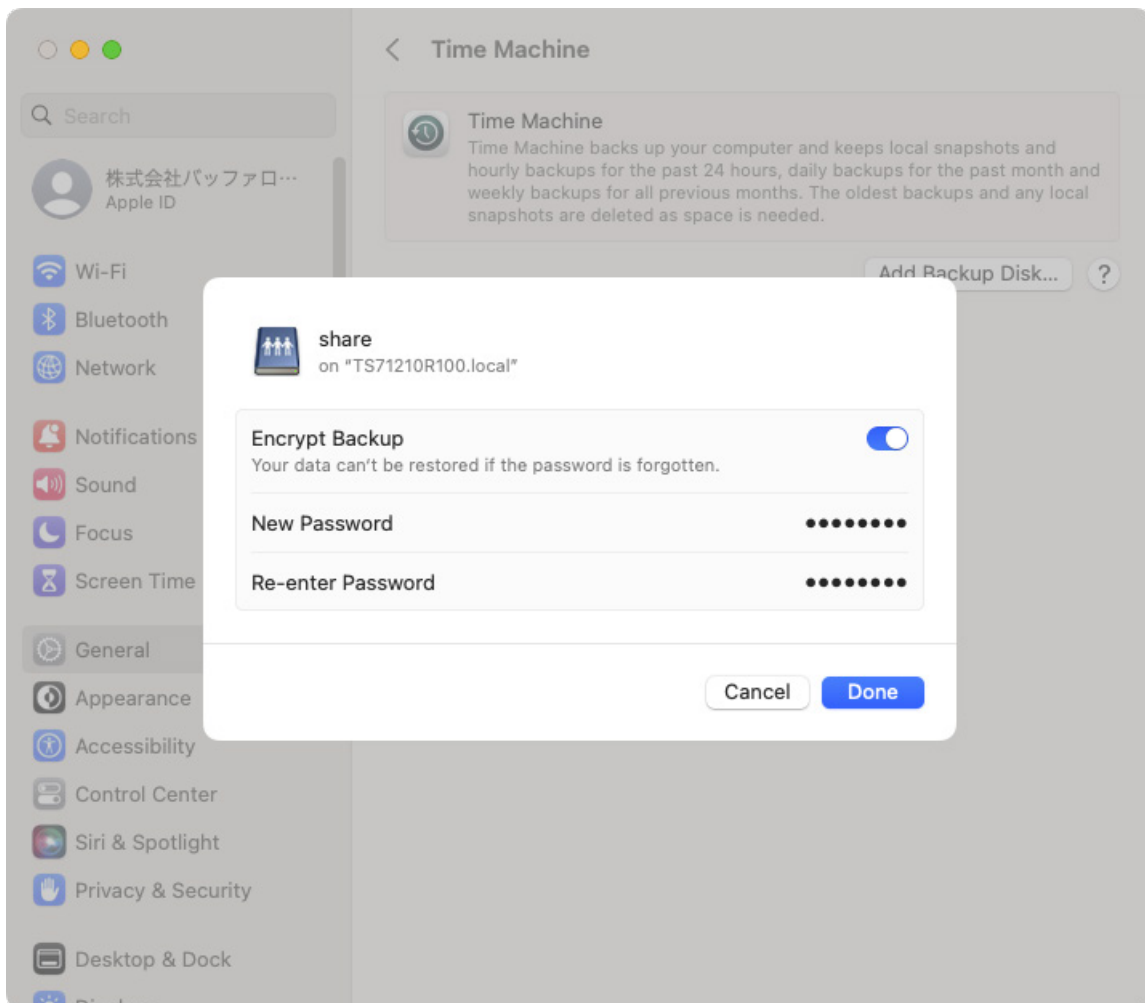

8 The process is complete once Time Machine finishes counting down from 60 seconds. The backup process will then start.

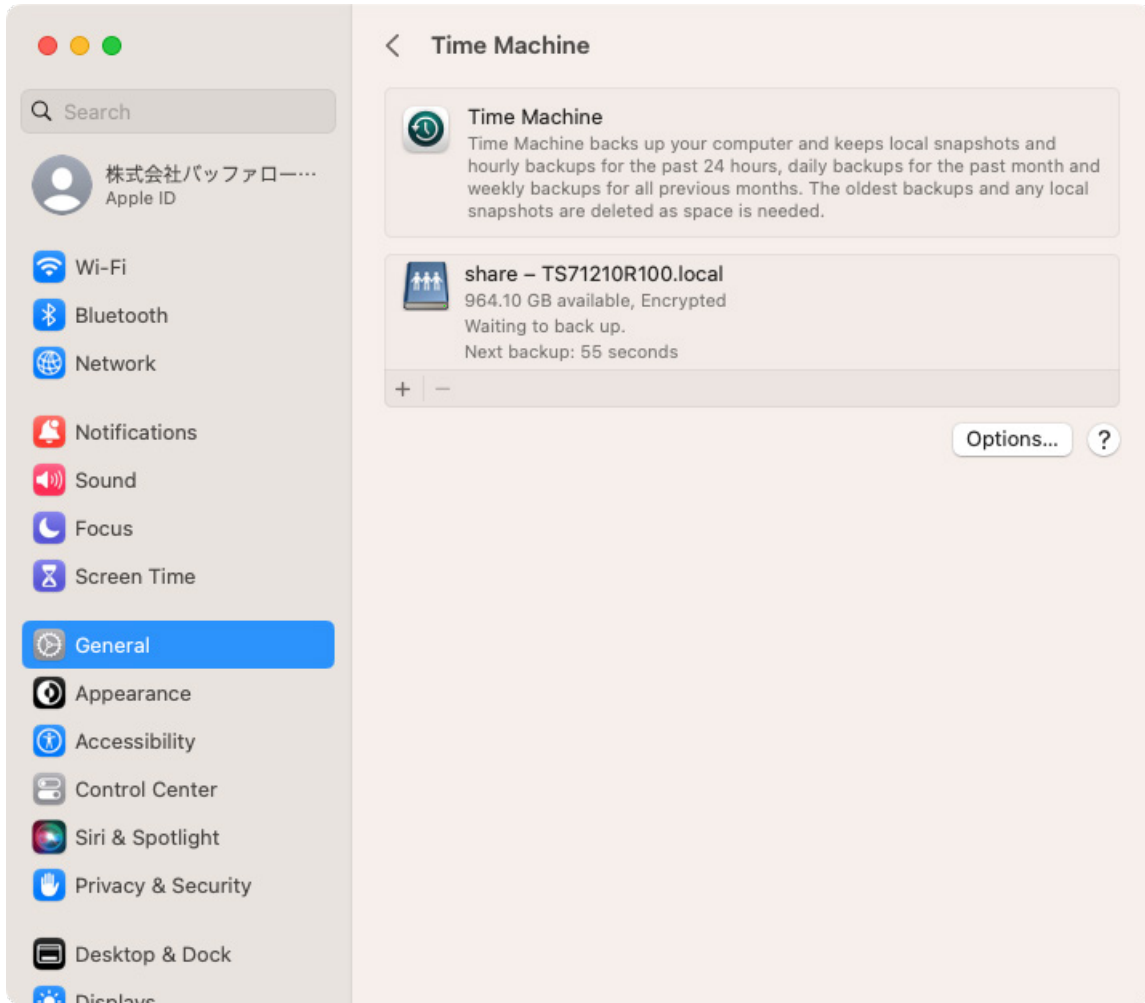

Chapter 7 Cloud Services and Remote Access

Synchronizing with Amazon S3-Compatible Storage

The TeraStation supports Amazon S3, a fee-based online storage service provided by Amazon, as well as select cloud storage services that share the Amazon S3 API such as Wasabi Cloud Storage.

The procedures in this section use the example of synchronizing with Amazon S3.

Depending on the services you have purchased, prices for operations and amount of data will vary. To avoid being charged unexpectedly expensive fees, we recommend staying aware of the price structure for data storage and operations and regularly checking how much have been charged.

As a cost-saving measure, instead of uploading data directly to the Amazon S3 remote folder, we recommend using backups. Refer to the [“Uploading Files to Amazon S3”](#) section below for more information.

Notes:

- Set the TeraStation’s time settings to the correct time. Using NTP is recommended. To configure NTP settings on the TeraStation, refer to the [“Name, Date, Time, and Language”](#) section in chapter 11.
- If using Amazon S3-compatible storage through a proxy server, click *Proxy Server* and select whether to use the configured settings or configure an identical proxy server. If using an identical proxy server, select “New settings” and enter the proxy server name, port number, username, and password. Consult your network administrator for detailed proxy server settings.
- This function doesn’t support Amazon S3 Glacier or S3 Object Lock.

Creating an Amazon S3 Job

Follow the procedure below to create a new job.

Note: You may not be able to create a job immediately after creating a bucket. In such a case, wait for a while and try again. It could take up to 24 hours after the bucket is created for job creation to be possible.

1 From the Amazon S3 portal, create your Amazon S3 account and a bucket before proceeding with the procedure.

2 From Settings, click *Cloud Storage*.

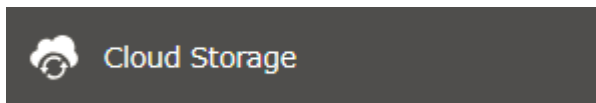

3 Click the settings icon () to the right of “Amazon S3-Compatible Storage”.

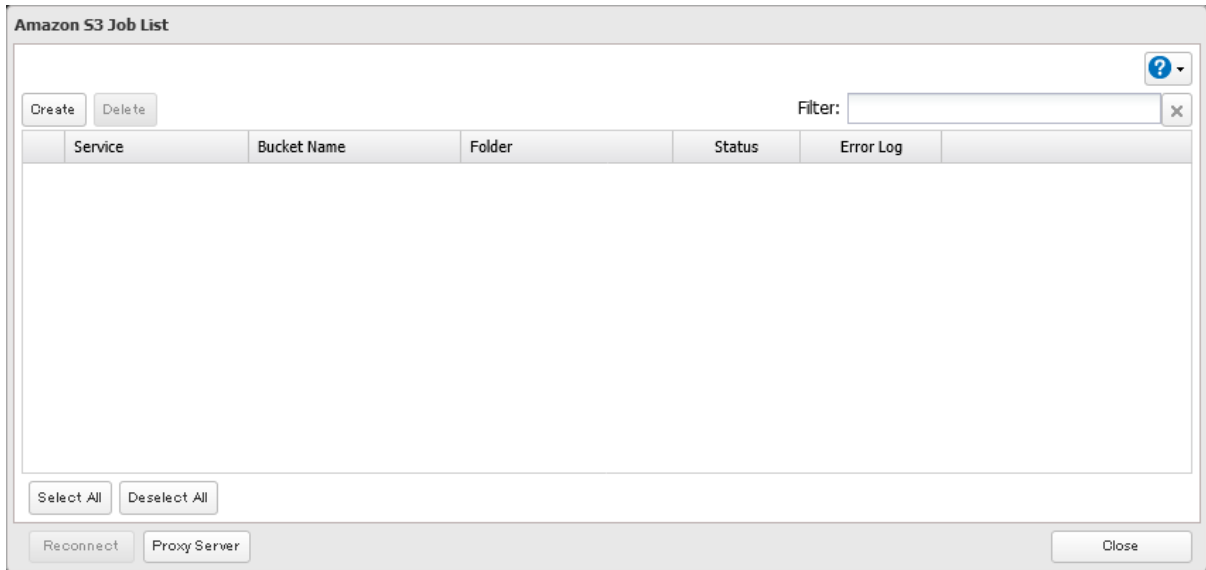
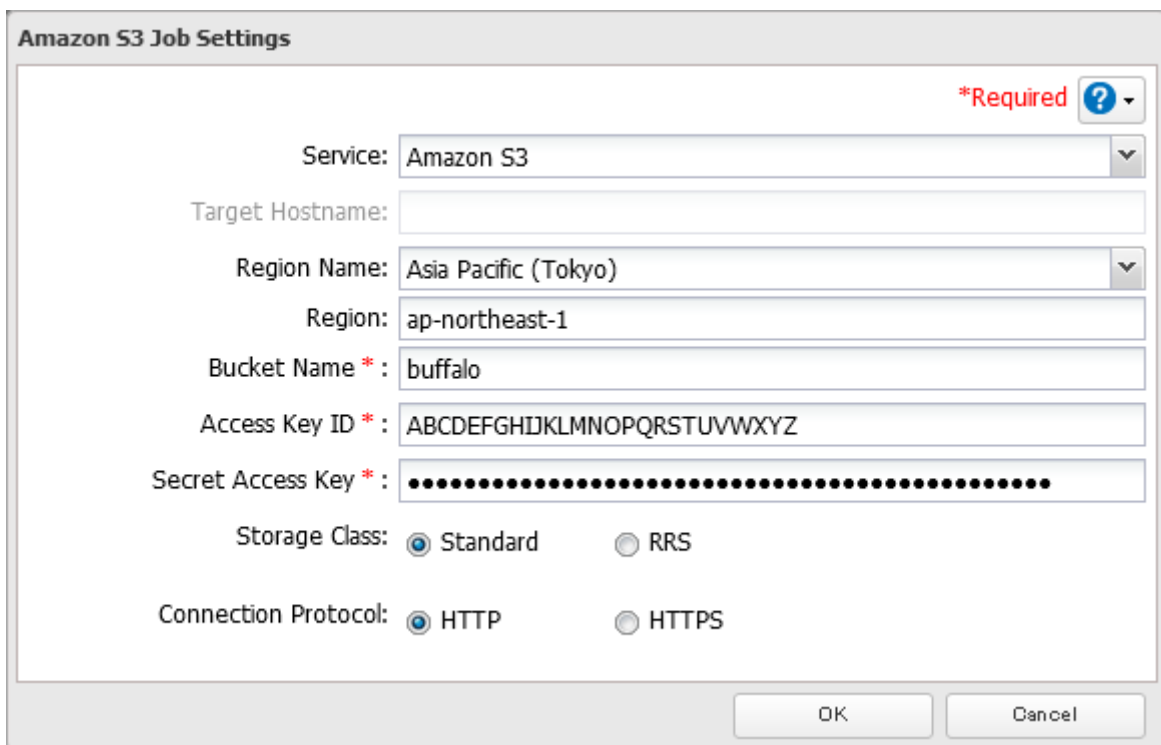

4 Click *Create*.**5** Select the service name and region name that you have selected when creating the bucket from the drop-down list. Enter the bucket name, access key ID, and secret access key; select the storage class and the connection protocol, then click *OK*.

- 6** Enter a remote folder name to use with Amazon S3 and click *OK*.

- 7** Under “LAN Protocol Support”, select the “Backup” checkbox on the *Basic* tab.

- 8** Click *OK*.

- 9** Enter the desired characters into the backup device access key field and click *OK*.

- 10** Configure the desired shared folder settings, then click *OK*.

- 11** The process is complete once you close the confirmation window that appears.

Notes:

- If a remote folder created through this process is configured to use NFS, it cannot be mounted from an NFS client.
- Files cannot be uploaded to this remote folder using WebAccess.

- Do not configure a folder that is created through the procedure above as a replication destination folder.
- If you enter an incorrect bucket name and then cancel editing the Amazon S3 settings, the incorrect bucket name may still accidentally be registered. If this occurs, start from step 4 above and reconfigure the Amazon S3 settings correctly.

Uploading Files to Amazon S3

Uploading files directly to the Amazon S3 remote folder will result in increased fees. To minimize costs, we recommend saving data to a shared folder and then regularly backing it up to the Amazon S3 remote folder. The procedure below outlines using backups to store files in an Amazon S3 bucket instead of saving data directly into the remote folder.

Note: To prevent unexpected data corruption while uploading to Amazon S3, the TeraStation will temporarily copy the upload data to another location. This will require free space at least equal to the total occupied size of an Amazon S3 remote folder.

- 1 From Settings, click *Backup*.



- 2 Click the settings icon () to the right of "Backup".



- 3 If you had configured a backup device access key for the remote folder that was created through the ["Creating an Amazon S3 Job"](#) section above, click *Set*. If you hadn't, skip to step 5.

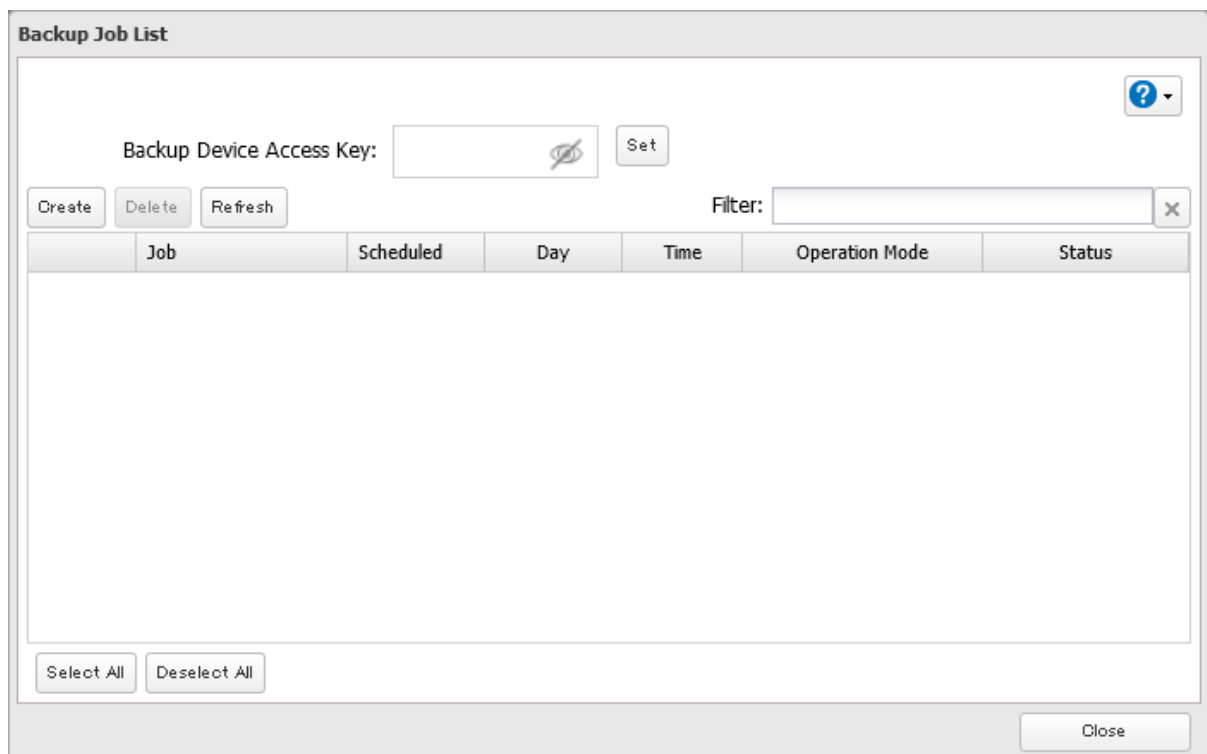

- 4** Enter the backup device access key and click *OK*.

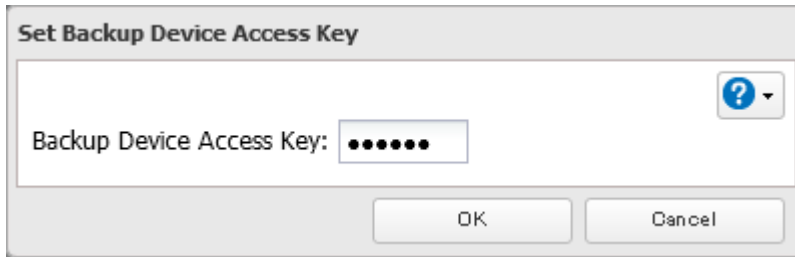

The dialog box titled "Set Backup Device Access Key" contains a text input field with the label "Backup Device Access Key:" followed by seven black dots. To the right of the input field is a blue question mark icon with a downward arrow. At the bottom of the dialog are two buttons: "OK" and "Cancel".

- 5** Click *Create*.

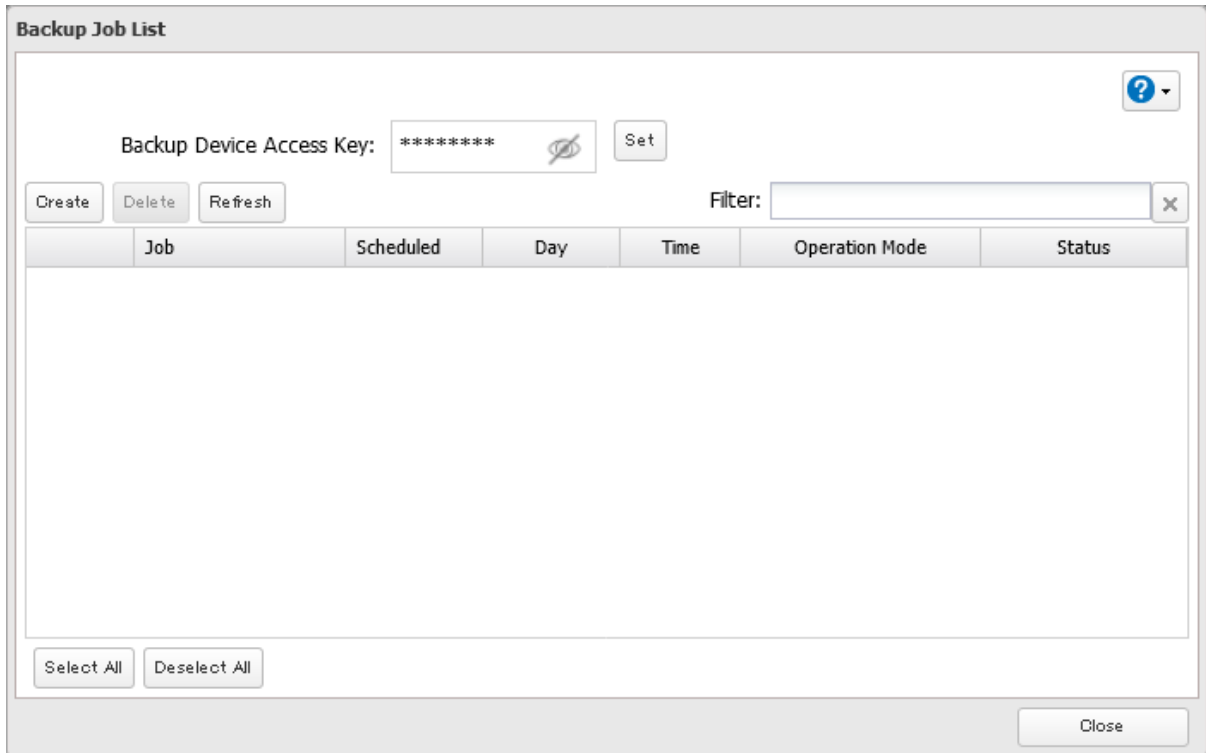

The "Backup Job List" window features a header with a blue question mark icon. Below the header is a "Backup Device Access Key:" label followed by a text field containing seven asterisks, a lock icon, and a "Set" button. Underneath are three buttons: "Create", "Delete", and "Refresh". To the right is a "Filter:" label and an empty text input field with a close button (X). The main area is a table with the following columns: Job, Scheduled, Day, Time, Operation Mode, and Status. The table is currently empty. At the bottom left are "Select All" and "Deselect All" buttons. At the bottom right is a "Close" button.

Job	Scheduled	Day	Time	Operation Mode	Status
-----	-----------	-----	------	----------------	--------

- 6** Select backup settings such as date and time to run, then select a backup mode for the "Operation Mode" drop-down list. It is recommended to configure a job to run periodically. Refer to the differences between the backup modes from the "[Backup Modes](#)" section in chapter 6.

Note: If you create a differential backup job and there are files that only exist in the destination folder, these files will be deleted when the job runs. Make sure that files are not saved when creating a backup job.

The screenshot shows the 'Backup Job Settings' dialog box. It has a title bar and a close button in the top right corner. The main area contains several fields and options:

- Job Name ***: A text input field with a red asterisk and a help icon.
- Schedule**: A dropdown menu set to 'Not scheduled', followed by a day dropdown set to 'Sunday', and two time dropdowns set to '00' and ': 00'.
- Operation Mode**: A dropdown menu set to 'Full backup'.
- Versions**: A spinner box set to '10' and a checked checkbox for 'Unlimited'.
- Options**: A section with a collapse/expand arrow and a list of checkboxes:
 - Create a subfolder for backup
 - Create backup log file
 - Save backup logs in the backup source folder
 - Select the folder to save backup logs
 - Target Folder:
 - Encrypted data transfer
 - Compress and transfer
 - Ignore backup errors and continue backup job on schedule
 - Do not back up recycle bin
 - Overwrite unchanged files
 - Inherit subfolders' access restrictions
 - Back up all snapshots

At the bottom right, there are 'OK' and 'Cancel' buttons.

7 Click *Add*.

- 8** Select the shared folder that files will be saved to as a source, and the remote folder created through the [“Creating an Amazon S3 Job”](#) section above as a destination.

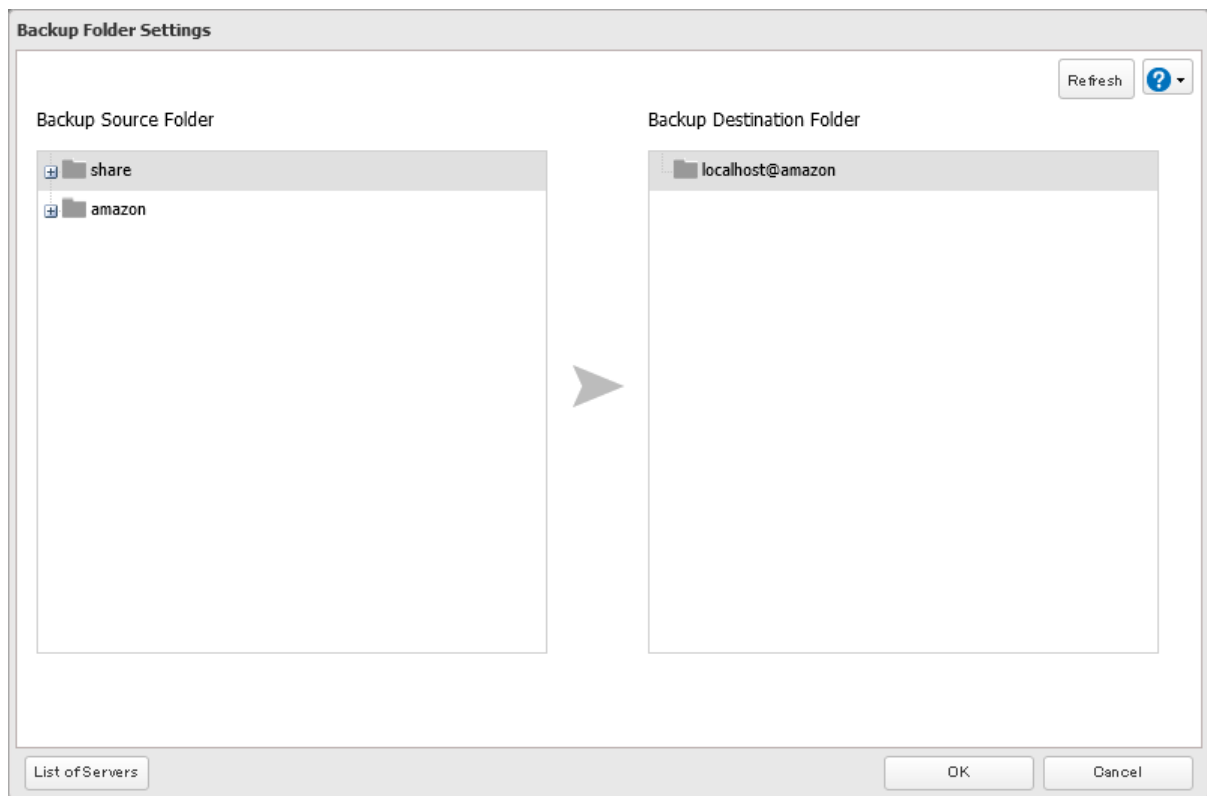

- 9** Click *OK*, then click *OK* again.

- 10** The process is complete once you close the confirmation window that appears. The backup job will be added to the backup jobs list.

Notes:

- To use the service after the network was temporarily disconnected, click *Reconnect*.
- If a file is directly added to the Amazon S3 bucket, the file will not be replicated to the remote folder.
- Do not copy 100,000 or more files to the backup source folder at once. If you do and uploading fails, check the network environment speed and try again with fewer files.
- Be careful with existing files in the remote folder, as files with the same name will be overwritten even if copied files are older.
- If you copy a file to the shared folder using File Explorer or a backup process, the file will also be uploaded sequentially to the Amazon S3 bucket. This second uploading process will start in the background during the first copying process and will not be visible. If the TeraStation is shut down or restarted immediately after copying a file to the shared folder, changing the settings, or disconnecting and reconnecting the Ethernet cable, the file may not be uploaded to the bucket. Try copying the file again if this occurs.
- If you encounter any upload or download errors, click *Error Log*. The log will display the filename and operation during which the error occurred.
- If uploading fails, try copying the file again. If it still fails, click *Reconnect* or set the Amazon S3-compatible storage switch to off and on again, then restart the function service.
- If accessing or transferring files that total 1 TB or more to the Amazon S3 bucket, make sure there is enough free space on the TeraStation for temporary file caching. For example, when uploading 1 TB of files to the bucket, it is recommended to keep at least 2 TB of free space available.

Synchronizing with Box

The TeraStation supports synchronizing with Box, the online cloud storage service. Once linked, you can share files on the TeraStation via Box (or files on Box via the TeraStation). Follow the procedure below to configure your TeraStation for use with Box.

Notes:

- To use Box Storage Sync, you will need a Box account and an available empty Box folder. If you don't have a Box account, or if you need to create a Box folder, refer to the Box website.
- Read the Fair Usage Policy by Box carefully before use to comply with it. The policy can be referred to from <https://www.box.com/legal/fairusepolicy>.
- Set the TeraStation's time settings to the correct time. Using NTP is recommended. To configure NTP settings on the TeraStation, refer to the "[Name, Date, Time, and Language](#)" section in chapter 10.
- If using Box through a proxy server, click *Proxy Server* and select whether to use the configured settings or configure an identical proxy server. This function is only available if using a proxy server with the HTTP protocol. If a proxy server with the HTTPS protocol has already been configured, or if using an identical proxy server, select "New settings" and enter the proxy server name (which is the HTTP protocol), port number, username, and password. Consult your network administrator for detailed proxy server settings.



Creating a Box Storage Sync Job

Follow the procedure below to create a new job.

1 From the Box portal, create your Box account before proceeding with the procedure.

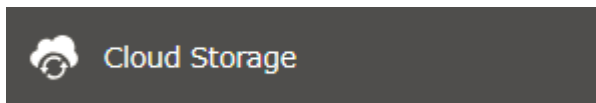
2 From Settings, click *Cloud Storage*.



3 Move the Box Storage Sync switch () to the  position to enable Box Storage Sync.

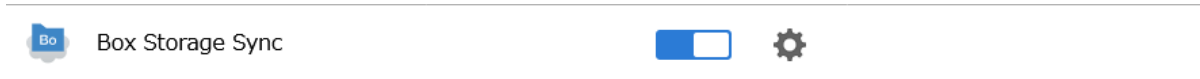

4 Click the settings icon () to the right of "Box Storage Sync".

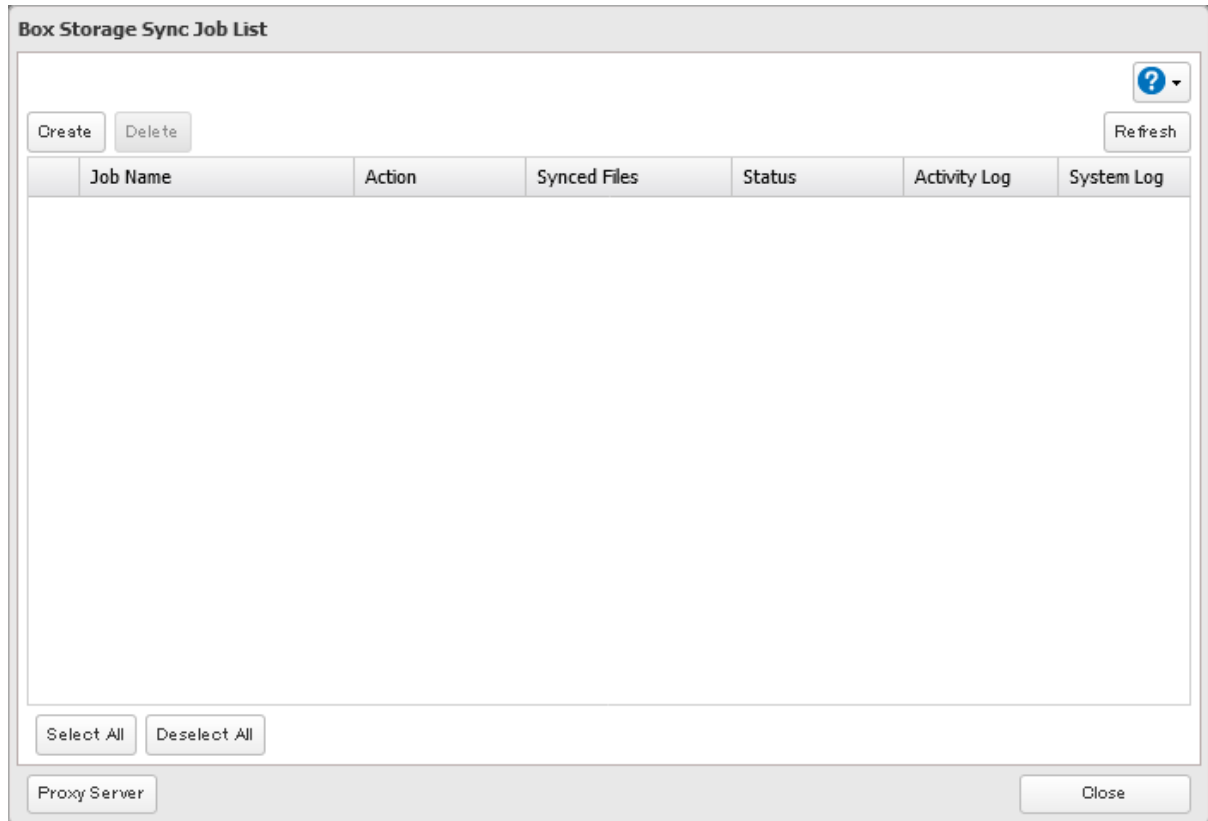

5 Click *Create*.**6** The sign-in window will open in a different tab. Enter the username and password of your Box account, then sign in.

Note: If you are using Firefox, you may not be automatically redirected from the sign-in page back to the Box Storage Sync job page. In such a case, manually navigate back to the job page. After the job is created, close the extra tab.

7 Enter the desired job name and click *Next*.

Job Setup Wizard for Box Storage Sync - Step 1 of 10

Enter a Job Name

Enter a name for the job to be created.

 ?

- 8** Select the sync action and behavior for when files with the same name are already in the target folder, then click *Next*.

There are three types of sync actions: bidirectional, uploading, and downloading. If bidirectional is selected as the sync action, files on both Box and the TeraStation will be updated. If uploading is selected as the sync action, only files on Box will be updated. If downloading is selected as the sync action, only files on the TeraStation will be updated. Both uploading and downloading will delete files from the sync destination folder that don't already exist on the source folder.

The behavior for when files with the same name already exist will apply if those files are changed on both the TeraStation and Box.

Job Setup Wizard for Box Storage Sync - Step 2 of 10

Select Sync Action

Select the sync action for your files.

Upload

Files with Same Names

- Keep files on Box
If there is a file conflict when syncing, files on Box will be saved over other versions.
- Keep files on the TeraStation
If there is a file conflict when syncing, files on the TeraStation will be saved over other versions.
- Keep files with newer modified date
If there is a file conflict when syncing, files with the newer modified date will be saved over other versions.

Back Next Cancel

- 9 Select the desired TeraStation and Box folders. Do not use a TeraStation shared folder that is currently being used for certain TeraStation functions such as cloud storage sync jobs, including existing Box Storage Sync jobs. If you want to create an empty folder first, click *Browse* under “Folder on TeraStation”, then click *Create Folder* on the selecting folder window that appears. Click *Next* after selecting the folders.

Job Setup Wizard for Box Storage Sync - Step 3 of 10

Configure Job Pairs

Select the Box and TeraStation folders you want to sync data between.

Folder on TeraStation	share	<input type="button" value="Browse"/>
Folder on Box	/Box_Storage_Sync	<input type="button" value="Browse"/>

Note: The sixth level and deeper of shared and Box folders cannot be selected.

- 10** Specify the sync method and click *Next*. If you have selected “Sync using configured time settings” for the sync method, skip to step 12.

Job Setup Wizard for Box Storage Sync - Step 4 of 10

Configure Sync Method

Select the sync method to use between the Box and TeraStation folders.

Sync at specified recurring intervals
This option will start the next synchronization occurrence at every specified minute mark of the hour.

60 minute mark

Sync using configured time settings
This option will start the next synchronization occurrence at the specified start time and frequency.

Frequency: Daily

Start Time: 00:00

Day of Week

Sunday Monday Tuesday Wednesday Thursday Friday Saturday

Back Next Cancel

Note: If “Sync at specified recurring intervals” is selected, the sync process will start running at the beginning of every hour and at every time interval you set. For example, if “15-minute mark” is selected, synchronization will begin as soon as the hour starts, followed by every 15-, 30-, and 45-minute mark of the hour.

- 11** Configure the sync frequency. Files will be uploaded during the start and end times of the interval configured in step 10 above. If you want to always upload files during the configured sync interval, select "Always sync within the specified interval" for "Frequency". Click *Next* after configuring.

Job Setup Wizard for Box Storage Sync - Step 5 of 10

Configure Sync Frequency

Configure a sync frequency for a job. If you select "Daily", specify the start and end time. If you select "Weekly", specify the day of the week and times.

Frequency

Start Time

End Time

Day of Week
 Sunday Monday Tuesday Wednesday Thursday Friday Saturday

- 12** Select whether to check for file consistencies. If a discrepancy is found between the files on the TeraStation and Box, that file will be updated to the latest version. Click *Next* after selections are finished.

Job Setup Wizard for Box Storage Sync - Step 6 of 10

Configure Consistency Check

Select whether to enable consistency checks. The hash values of files in the source and destination folders will be compared for uploading/downloading. If there are any inconsistencies between files, the system will try syncing again.

Enable Disable

Back Next Cancel

- 13** Select whether to limit the transfer speed. If you enable this feature, the file transfer speed between Box and the TeraStation will not exceed the configured speed.

Job Setup Wizard for Box Storage Sync - Step 7 of 10

Limit Transfer Speed

Configure whether to limit the transfer speed for Box Storage Sync, which will reduce network load and impact other functions.

Enable Disable

Maximum Speed:

- 14** Configure whether to filter the sync target files. The following screen enables file filtering configuration by file sizes and whether they're hidden. The file size filter will only apply to uploads. The available maximum size is up to 15,360 MB (15 GB). "Hidden files" refer to files whose filename starts with a period. Click *Next* after selections are finished.

Job Setup Wizard for Box Storage Sync - Step 8 of 10

Configure File Filters 1

Configure the requirements for filtering files. If any files in the folder on either the TeraStation or Box meet any of the following requirements, those files will not be synced.

Filter by File Size

Enable Disable

Maximum Size: MB

Filter Hidden Files

Enable Disable

Back Next Cancel

- 15** Configure whether to filter the sync target files. The following screen enables file filtering configuration by extensions. Click *Next* after selections are finished.

- 16** Confirm that all settings are properly configured and click *OK*.

- 17** The process is complete once you close the confirmation window that appears.

Notes:

- Do not rename or delete any folders used for Box Storage Sync.
- Do not use UTF-8 4-byte characters (U+10000–U+10FFFF) such as emoji in file or folder names.
- Files whose name contains any of the symbols / \ > < : | ? * " ' ` may be unable to be synchronized. If synchronization fails, check whether these symbols are included in the filenames.
- Depending on your network environment, you may be unable to download larger files. To prevent this issue, divide a larger file into smaller files or compress the files to a smaller size before uploading them to Box.
- When files are uploaded from the TeraStation folder using Box Storage Sync and then downloaded onto a computer from Box, time stamps for files may be changed to the download date.
- Do not copy 1 million or more files to the TeraStation folder at once. If you do and synchronization fails, try again with fewer files.
- If a user creates a folder and another user shares a folder with the same name, both folders will appear in the Box console. In such a case, if either of these folders is selected as the destination folder for Box Storage Sync, the shared folder will always be used, even if you have selected the created folder. To avoid this, make sure newly-created folders have names different from any existing shared folders.
- If you create multiple jobs on the same Box account, files may be unable to be synchronized due to rate limits set by Box.

- If the “Unknown error.” message appears when signing in to Box, check that the network environment and proxy server settings are correct. If the message still persists, wait for a while and try again.
- If a file is saved into the shared folder using a macOS computer while the sync process is running, that file may not be copied properly. The file will be copied during the next sync process.

Changing Job Settings

Follow the procedure below to change any job settings you have already configured.

- 1 From Settings, click *Cloud Storage*.

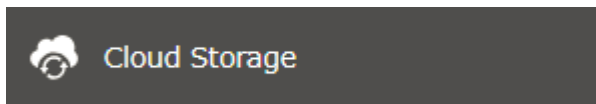

- 2 Click the settings icon () to the right of “Box Storage Sync”.

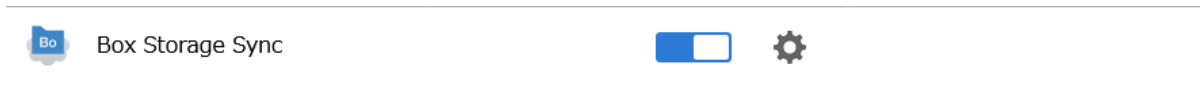

- 3 From the job list, click the job whose settings you want to change.

Box Storage Sync Job List

	Job Name	Action	Synced Files	Status	Activity Log	System Log
<input type="checkbox"/>	job01	Upload	0/0	Inactive	View Log	View Log

- 4** From the *Options* tab, click *Edit* and configure the desired settings, then click *OK*.

- 5** The process is complete once you close the confirmation window that appears.

Corrective Actions for in Case of Error

If an error occurs, the I64 message will appear as a notification. Click *Clear* to delete the message from the Dashboard in Settings.

Error Appears in the “Status” Field of Job List

If any of the following messages appear in the “Status” field of the job list, the synchronization process did not complete properly. In such a case, try the corresponding corrective action.

Message	Description	Corrective Action
Failed in the past	There are some files that could not be synced.	Unsynced files will be synchronized in a subsequent job.
Low drive space	The capacity of the TeraStation has become full.	Delete unnecessary files and folders.
Low cloud storage space	The capacity of the cloud storage has become full.	Delete unnecessary files and folders.
Server busy	The cloud storage server is temporarily busy.	Please wait for about 10 minutes and try again.
Communication error	The TeraStation could not communicate with the cloud storage server.	Check that the network environment and proxy server settings are correct.

Message	Description	Corrective Action
Token error	An error occurred on a token.	<p>Update the token by following the procedure below.</p> <ol style="list-style-type: none"> 1 From Settings, click <i>Cloud Storage</i>. 2 Click the settings icon () to the right of “Box Storage Sync”. 3 From the job list, click the job with the occurring token error. 4 Click <i>Update Token</i> at the bottom-left of the window. 5 The process is complete once you close the confirmation window that appears.

Error Appears While Creating a Job or Error Code Appears on the System Log

When creating Box Storage Sync jobs, you may see error messages with the following error codes. The system log may contain these codes as well. If you encounter any of the following error codes, refer to the table below and try the respective corrective action. If the error code is not listed on the table, refer to the Box website instead: <https://developer.box.com/guides/api-calls/permissions-and-errors/common-errors/>.

HTTP Status Code	Error	Message	Corrective Action
400 Bad Request	cyclical_folder_structure	Moving a folder has created a cyclical folder structure.	Delete the cyclical folders (folders that are cross-referencing).
400 Bad Request	item_name_invalid	The file or folder name contains invalid characters.	Rename the files or folders to not contain any of the invalid characters described in the “Creating a Box Storage Sync Job” section above.
400 Bad Request	item_name_too_long	The file or folder name is too long.	Shorten the length of the name to 255 bytes or less.
403 Forbidden	access_denied_insufficient_permissions	You don’t have appropriate permissions to move files.	Make sure a user has the appropriate permissions.
403 Forbidden	access_denied_item_locked	You are attempting to access a locked file or folder without the appropriate permissions.	Unlock the files or folders.
403 Forbidden	file_size_limit_exceeded	The file size exceeds the maximum size limit of the folder owner’s account.	Reduce the file size.
403 Forbidden	forbidden_by_policy	You don’t have appropriate permissions to copy files.	Make sure a user has the appropriate permissions.
403 Forbidden	storage_limit_exceeded	The account’s storage limit has been reached.	Files can no longer be uploaded. Delete unnecessary files from the storage, or reduce the size of the upload target files.

HTTP Status Code	Error	Message	Corrective Action
429 Too Many requests	rate_limit_exceeded	The request rate limit has been exceeded.	Check whether multiple jobs have been created or if too much data has been transferred using the same Box account. In such a case, wait for a while and try again or reduce the number of jobs that are concurrently running.
500 Internal Server Error	internal_server_error	An internal server error occurred on the Box server.	Please wait for about 10 minutes and try again.
502 Bad Gateway	bad_gateway	A communication error occurred with the Box server.	Please wait for about 10 minutes and try again.
503 Unavailable	unavailable	The request could not be processed by the Box server.	Please wait for about 10 minutes and try again.
503 Unavailable	-	The maximum process limit has been exceeded.	Please wait for about 10 minutes and try again.
504 Gateway Timeout	-	The session timed out before the process completed.	Please wait for about 10 minutes and try again.
-	disk quota exceeded	The quota capacity has been reached.	Files can no longer be downloaded. Delete unnecessary files from the remote folder on the TeraStation or expand the quota capacity settings.
-	file too big for remaining disk space	There is not enough free space on the TeraStation.	Files can no longer be downloaded. Delete unnecessary files from the TeraStation.

Synchronizing with Dropbox

The TeraStation supports synchronizing with Dropbox, the online cloud service. Once linked, you can share TeraStation files via Dropbox (or Dropbox files via TeraStation). Follow the procedure below to configure your TeraStation for use with Dropbox.

Notes:

- To use Dropbox Sync, you will need a Dropbox account and an available empty Dropbox folder. If you don't have a Dropbox account, or if you need to create a new empty Dropbox folder, refer to the Dropbox website.
- If using Dropbox through a proxy server, click *Proxy Server* and select whether to use the configured settings or configure an identical proxy server. If using an identical proxy server, select "New settings" and enter the proxy server name, port number, username, and password. Consult your network administrator for detailed proxy server settings.
- This function doesn't support linking with team folders.

Creating a Dropbox Sync Job

Follow the procedure below to create a new job. Up to eight Dropbox jobs can be configured at a time.

1 From Settings, click *Cloud Storage*.

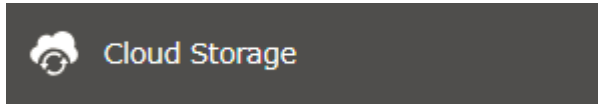

2 Move the Dropbox Sync switch () to the  position to enable Dropbox Sync.



3 Click the settings icon () to the right of "Dropbox Sync".



4 Click *Create*.

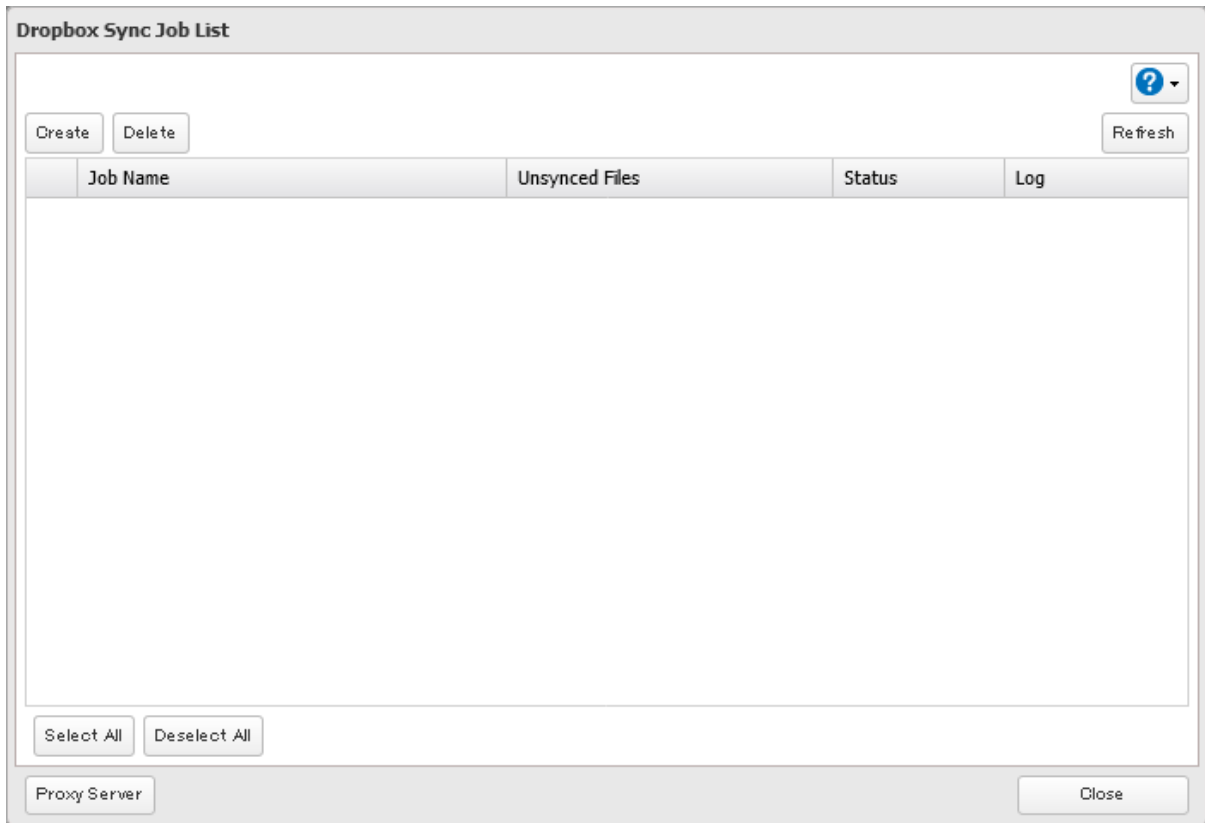

5 Click *View Dropbox Authentication Page*.

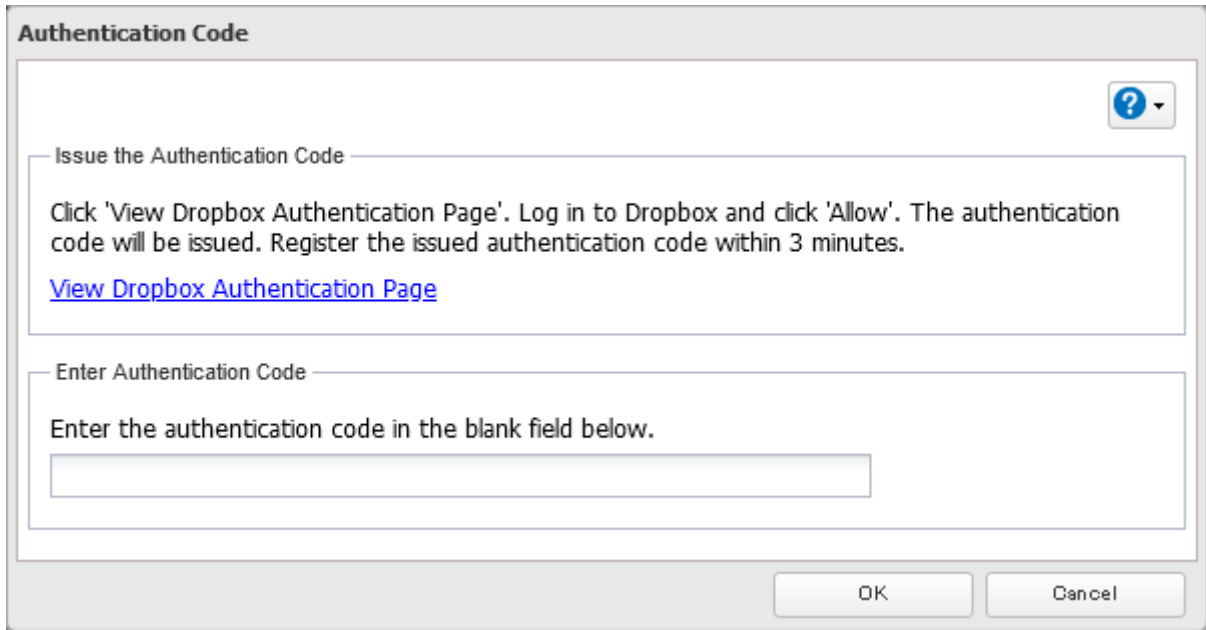

6 The authentication site that is offered by Dropbox will be displayed. Log in to the website with your Dropbox account, then click *Allow*.

7 The authentication code will be displayed. Copy the authentication code and return to Settings. Authentication code reregistration should be finished within three minutes.

8 Paste the authentication code and click *OK*.

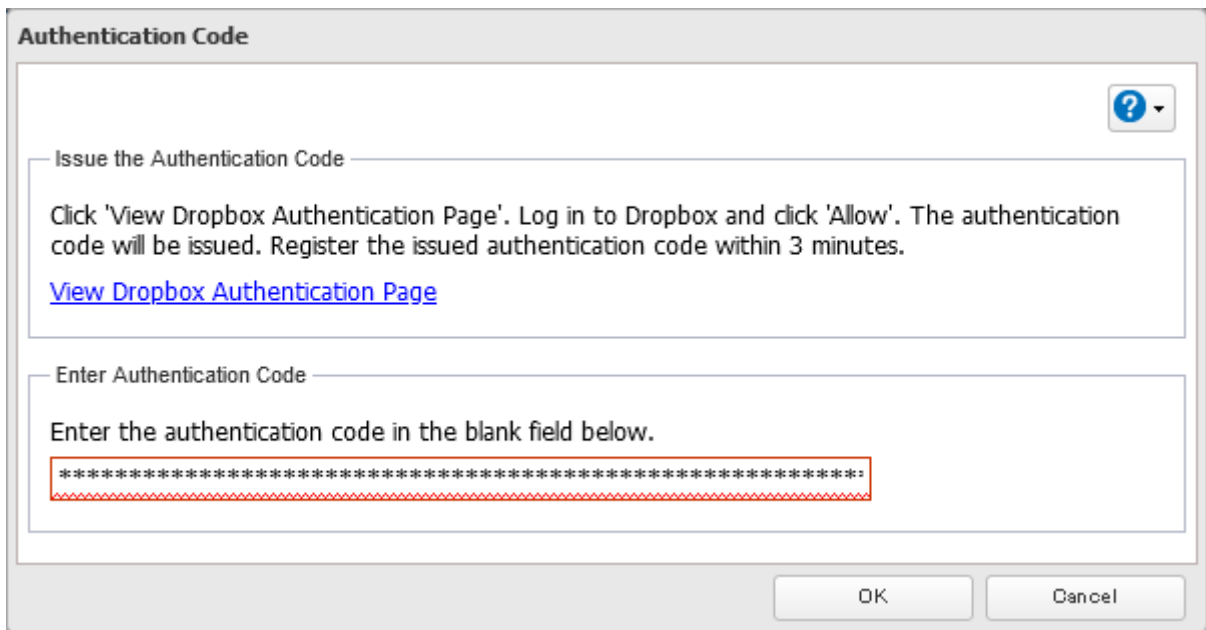

9 Enter the desired job name; select the TeraStation and Dropbox folders.

Note: Make sure to select the TeraStation folder that doesn't contain multibyte characters on its name. If the folder name contains multibyte characters, the job will fail.

Dropbox Sync Job Settings

Job Name * : job01

Folder on TeraStation * : share

Folder on Dropbox * : Dropbox/Dropbox_share

*Required ?

OK Cancel

10 Click *OK*. The process is complete once you close the confirmation window that appears.

Notes:

- Refer to the following website for synchronization restrictions between the TeraStation and Dropbox: <https://www.dropbox.com/help/145>
- Folders that are configured for Dropbox Sync cannot be renamed or used for replication.
- Files that are 900 MB or larger cannot be downloaded using Dropbox Sync. However, even if the file size is smaller than 900 MB, downloading may fail when multiple processes are running at the same time.

Changing Job Settings

Follow the procedure below to change any job settings you have already configured.

1 From Settings, click *Cloud Storage*.

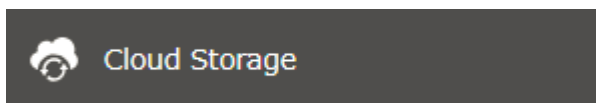

2 Click the settings icon (⚙️) to the right of "Dropbox Sync".



3 From the job list, click the job whose settings you want to change.

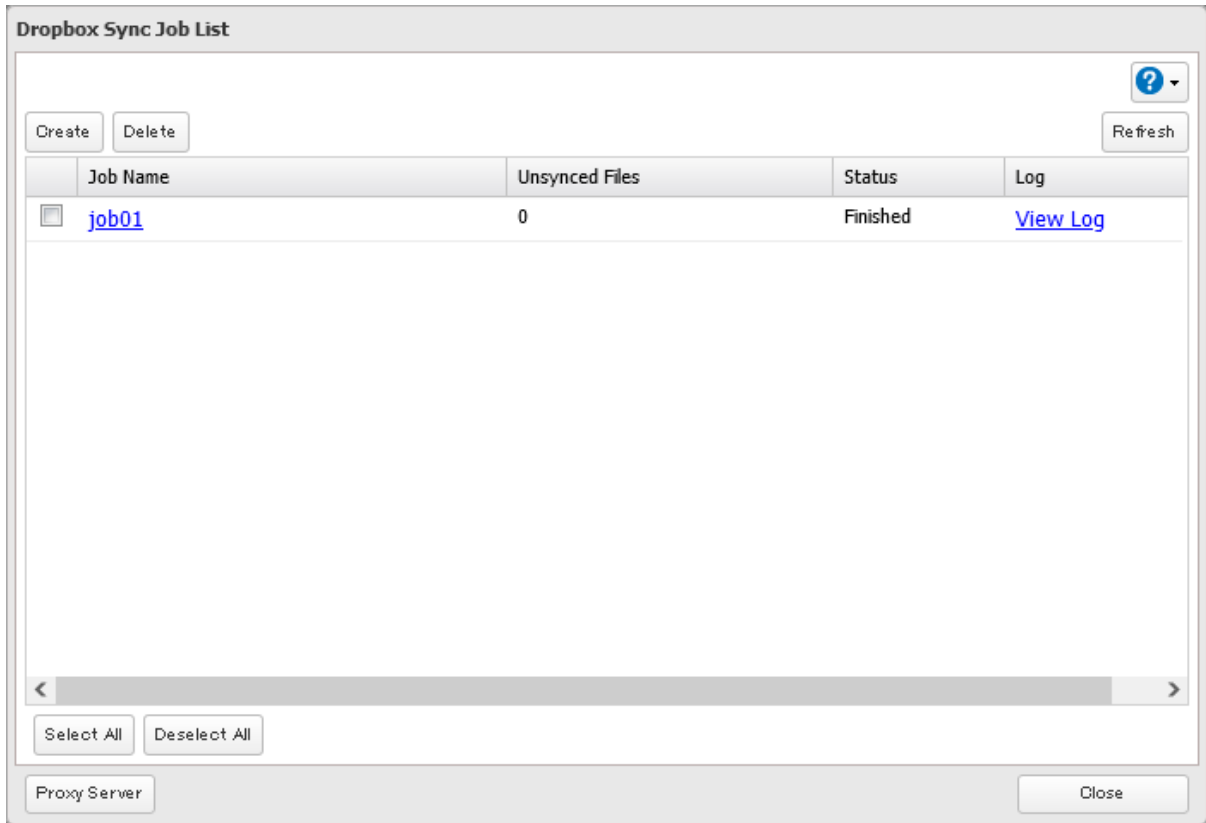

4 From the *Options* tab, click *Edit* and configure the desired settings, then click *OK*.

Dropbox Sync Job Settings

Sync Interval: 5 minutes

Sync Action: Bidirectional transfer

Filter by File Size: Enable Disable

Maximum Size: 1 MB

Filtered Extensions:

Extensions

Add Delete

Filter Hidden Files: Enable Disable

OK Cancel

5 The process is complete once you close the confirmation window that appears.

Notes:

- When specific settings are changed, the changes will not be applied and the files on Dropbox may not be synchronized to the TeraStation. In such a case, delete the target files to be synchronized and upload them to Dropbox again or delete the job and recreate it again. The following are the specific circumstances for when files may not be synchronized:
 - Uploading or downloading fails.
 - File extensions are removed from filtering.
 - The sync direction is changed.
- “Hidden files” from the “Filter Hidden Files” option refer to files whose filename starts with a period.
- Regardless of whether file filtering was configured, the following files will not be uploaded to Dropbox:
 - desktop.ini
 - thumbs.db
 - Files whose filename contains the symbols / \ > < : " | ? *
 - Files whose filename ends with either a space or period
 - Files whose filename starts with either ~\$ or .~
 - Files whose filename starts with ~ and have the file extension .tmp

Creating a Shared Link (Windows Only)

Buffalo offers a Windows application, “B-Sync”, that can create shared links for the files stored in the TeraStation folders. You can download the application from the [Buffalo website](#). Refer to the application help for the usage procedure.

Using Microsoft Azure for Data Preservation

The TeraStation supports synchronizing with Microsoft Azure, the online cloud storage service. Once linked, you can back up data on the TeraStation to Azure Storage, or restore data from Azure Storage to the TeraStation.

Microsoft Azure offers multiple types of storage and the TeraStation is compatible with blob storage. There are three types of blobs: block blobs, page blobs, and append blobs. The TeraStation only works with block blobs to store your data.

This feature is meant for situations such as disaster recovery and not a catch-all backup function. After linking the TeraStation and Microsoft Azure, data on the TeraStation will not be bidirectionally synchronized between the TeraStation and an Azure container.

Notes:

- Depending on the services you have purchased, prices for operations and amount of data will vary. To avoid being charged unexpectedly expensive fees, we recommend staying aware of the price structure for data storage and operations and regularly checking how much have been charged.
- To access data that have been backed up to the container, use “Microsoft Azure Storage Explorer”.
- If using Azure Storage through a proxy server, click *Proxy Server* and select whether to use the configured settings or configure an identical proxy server. If using an identical proxy server, select “New settings” and enter the proxy server name, port number, username, and password. Consult your network administrator for detailed proxy server settings.

Creating an Azure Storage Sync Backup Job

Follow the procedure below to create a new backup job.

1 From the Azure portal, create your Azure Storage account and a container before proceeding with the procedure.

2 From Settings, click *Cloud Storage*.

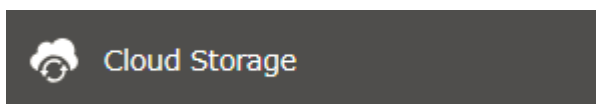

3 Move the Microsoft Azure Storage Sync switch () to the  position to enable Microsoft Azure Storage Sync.



4 Click the settings icon () to the right of “Microsoft Azure Storage Sync”.

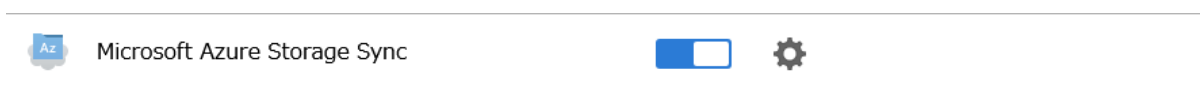

5 Click *Create*.

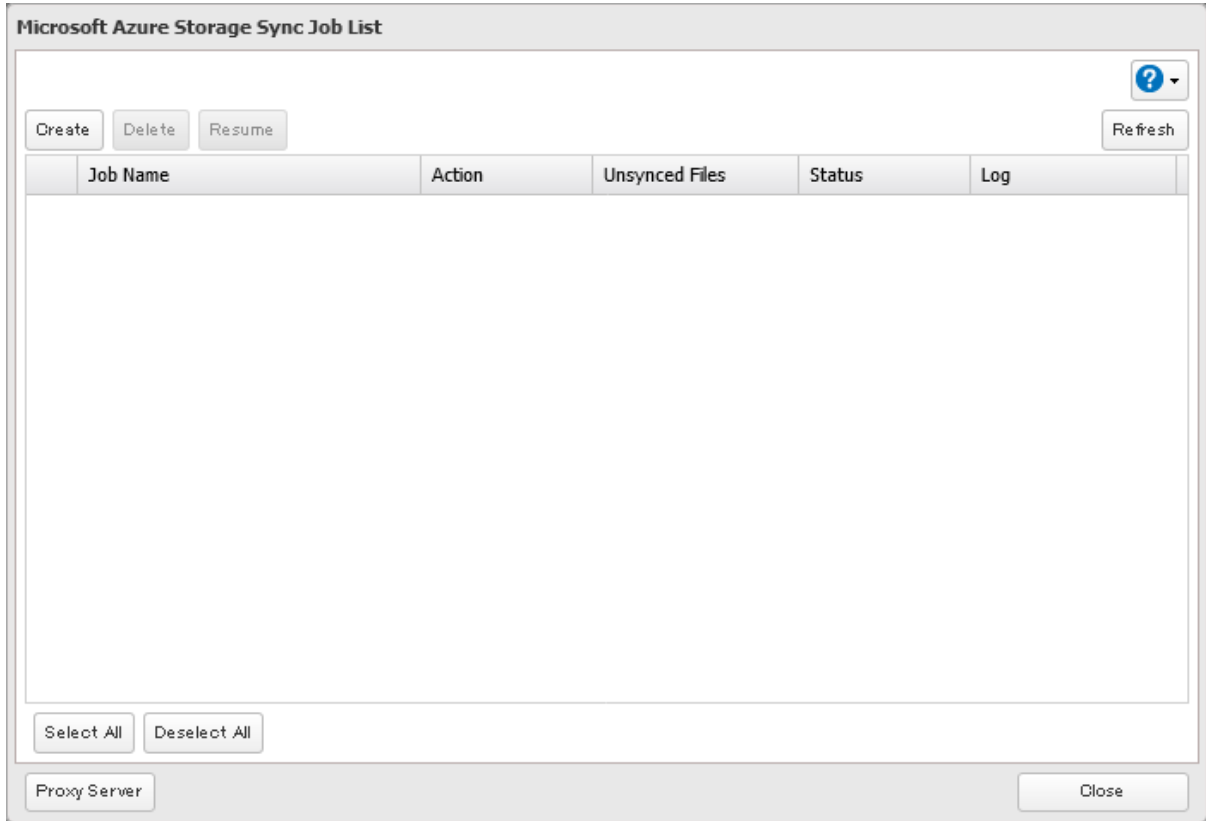

6 The job setup wizard will open. Enter your Azure Storage account name and access key, then click *Next*.

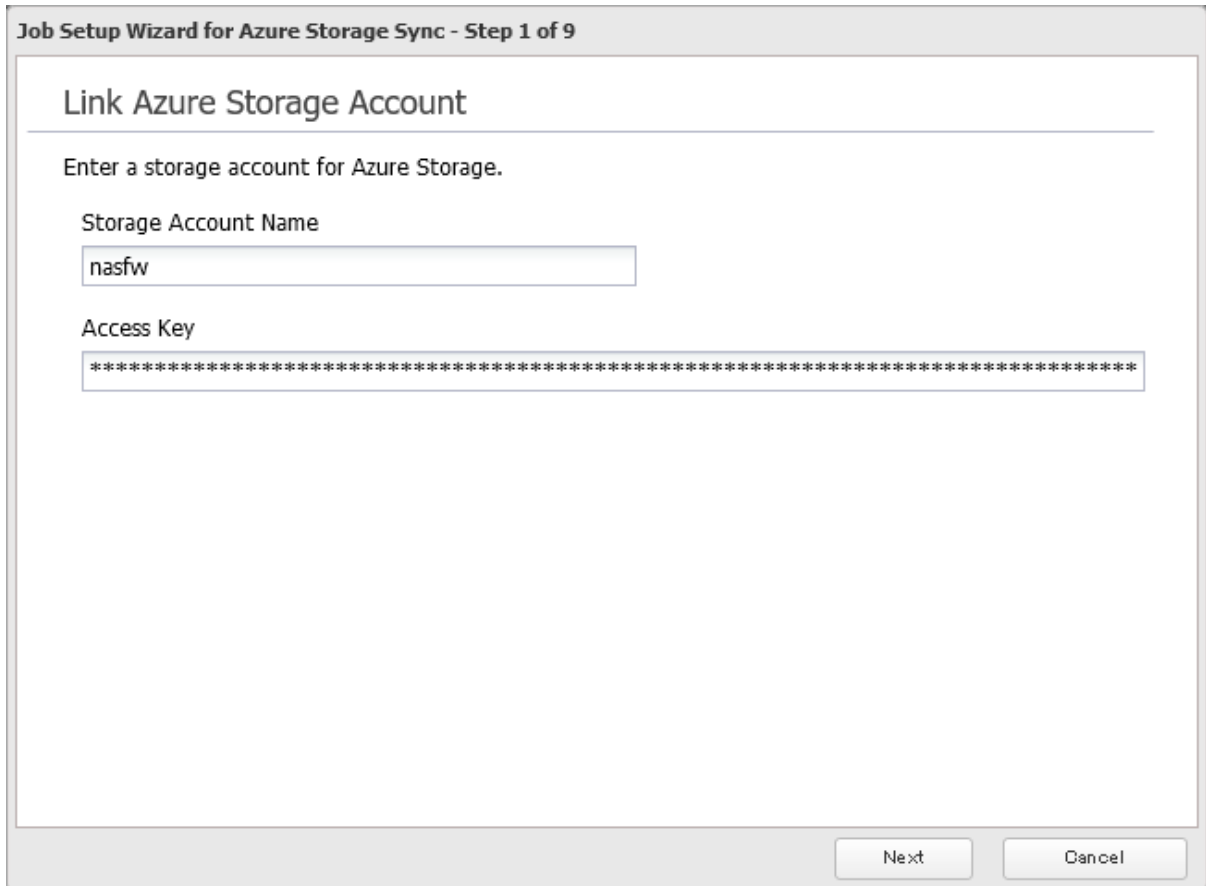

7 Enter the desired job name and click *Next*.

Job Setup Wizard for Azure Storage Sync - Step 2 of 9

Enter a Job Name

Enter a name for the job to be created.

Job Name

Back Next Cancel

8 Select “Backup” and click *Next*.

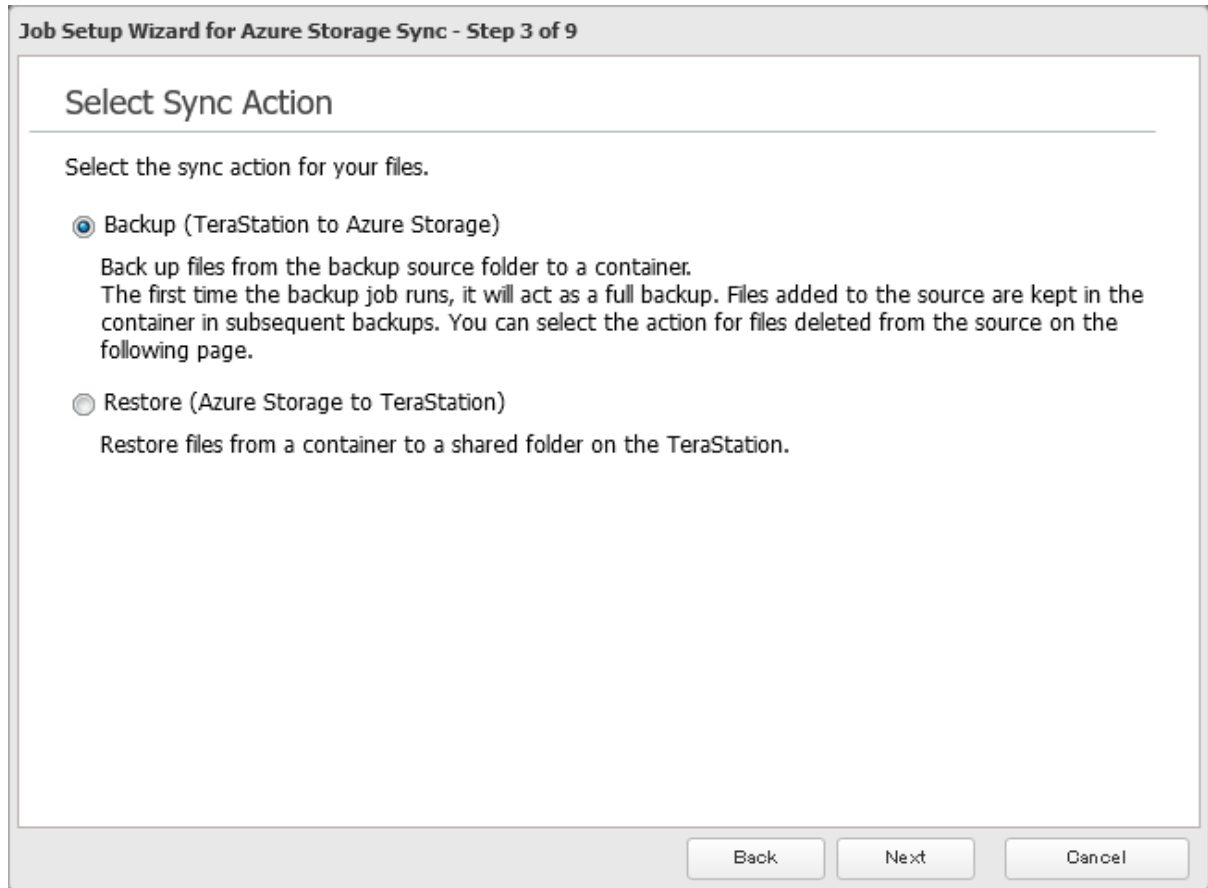

- 9 Select the desired shared folder on the TeraStation as the backup source folder. Do not use a TeraStation shared folder that is currently being used for certain TeraStation functions such as cloud storage sync jobs, including existing Azure Storage Sync jobs.

Job Setup Wizard for Azure Storage Sync - Step 4 of 9

Configure Job Pairs

Select the shared folder that contains desired files for backup as the backup source and enter a container name.

Backup Source Folder

share

Container Name

test001

- 10 Enter the container name for the backup destination, then click *Next*.

11 Specify the sync interval and click *Next*.

Job Setup Wizard for Azure Storage Sync - Step 5 of 9

Configure Sync Interval

Select the interval of time between each backup.

Backup Interval

5 minutes

Back Next Cancel

- 12** Select the desired action to take for files in the container that share the same name as files in the backup source after they are deleted, then click *Next*.

Job Setup Wizard for Azure Storage Sync - Step 6 of 9

Configure Sync Action for Deleted Files

Select the action to take for files in the backup destination container after deleting files with the same name from the backup source folder.

- Delete from container
Delete the files from the backup destination container.
- Keep in container
Keep the files as is in the backup destination container.

Back Next Cancel

13 Configure whether to filter the backup target files. The following screen enables file filtering configuration by file sizes and whether they're hidden. "Hidden files" refer to files whose filename starts with a period. Click *Next* after selections are finished.

Job Setup Wizard for Azure Storage Sync - Step 7 of 9

Configure File Filters 1

Configure the requirements for filtering files. If any files in the backup source folder meet any of the following requirements, those files will not be backed up.

Filter by File Size

Enable Disable

Maximum Size: MB

Filter Hidden Files

Enable Disable

Back Next Cancel

- 14** Configure whether to filter the backup target files. The following screen enables file filtering configuration by extensions. Click *Next* after selections are finished.

Job Setup Wizard for Azure Storage Sync - Step 8 of 9

Configure File Filters 2

Configure the requirements for filtering files. If any files in the backup source folder meet any of the following requirements, those files will not be backed up.

Filter by File Extension

Enable Disable

Filtered Extensions

Extensions

Add

Delete

Back Next Cancel

- 15** Confirm that all settings are properly configured and click *OK*.

- 16** The process is complete once you close the confirmation window that appears.

Notes:

- Regardless of whether file filtering was configured, the following files will not be backed up to an Azure Storage container:
 - desktop.ini
 - thumbs.db
 - Files whose filename contains the symbols / \ > < : " | ? *
 - Files whose filename ends with either a space or period
 - Files whose filename starts with either ~\$ or .~
 - Files whose filename starts with ~ and have the file extension .tmp
- Do not copy files that are 10 GB or larger, and do not copy 100,000 or more files to the backup source folder at once. If you do and backup fails, check the network environment speed and try again with fewer or smaller files.

Creating an Azure Storage Sync Restore Job

Follow the procedure below to create a new restore job.

- 1** From the Azure portal, create your Azure Storage account and a container before beginning the following procedure.

2 From Settings, click *Cloud Storage*.

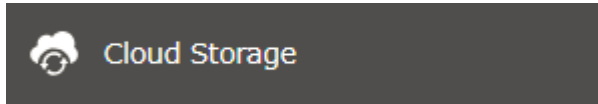

3 Move the Microsoft Azure Storage Sync switch () to the  position to enable Microsoft Azure Storage Sync.



4 Click the settings icon () to the right of "Microsoft Azure Storage Sync".



5 Click *Create*.

The screenshot shows a window titled "Microsoft Azure Storage Sync Job List". At the top left are buttons for "Create", "Delete", and "Resume". At the top right is a "Refresh" button and a help icon. Below these is a table with the following headers: "Job Name", "Action", "Unsynced Files", "Status", and "Log". The table body is currently empty. At the bottom left are "Select All" and "Deselect All" buttons. At the bottom right is a "Close" button. A "Proxy Server" label is visible at the bottom left of the window frame.

6 The job setup wizard will open. Enter your Azure Storage account name and access key, then click *Next*.

Job Setup Wizard for Azure Storage Sync - Step 1 of 9

Link Azure Storage Account

Enter a storage account for Azure Storage.

Storage Account Name

Access Key

Next Cancel

7 Enter the desired job name and click *Next*.

Job Setup Wizard for Azure Storage Sync - Step 2 of 9

Enter a Job Name

Enter a name for the job to be created.

Job Name

8 Select “Restore” and click *Next*.

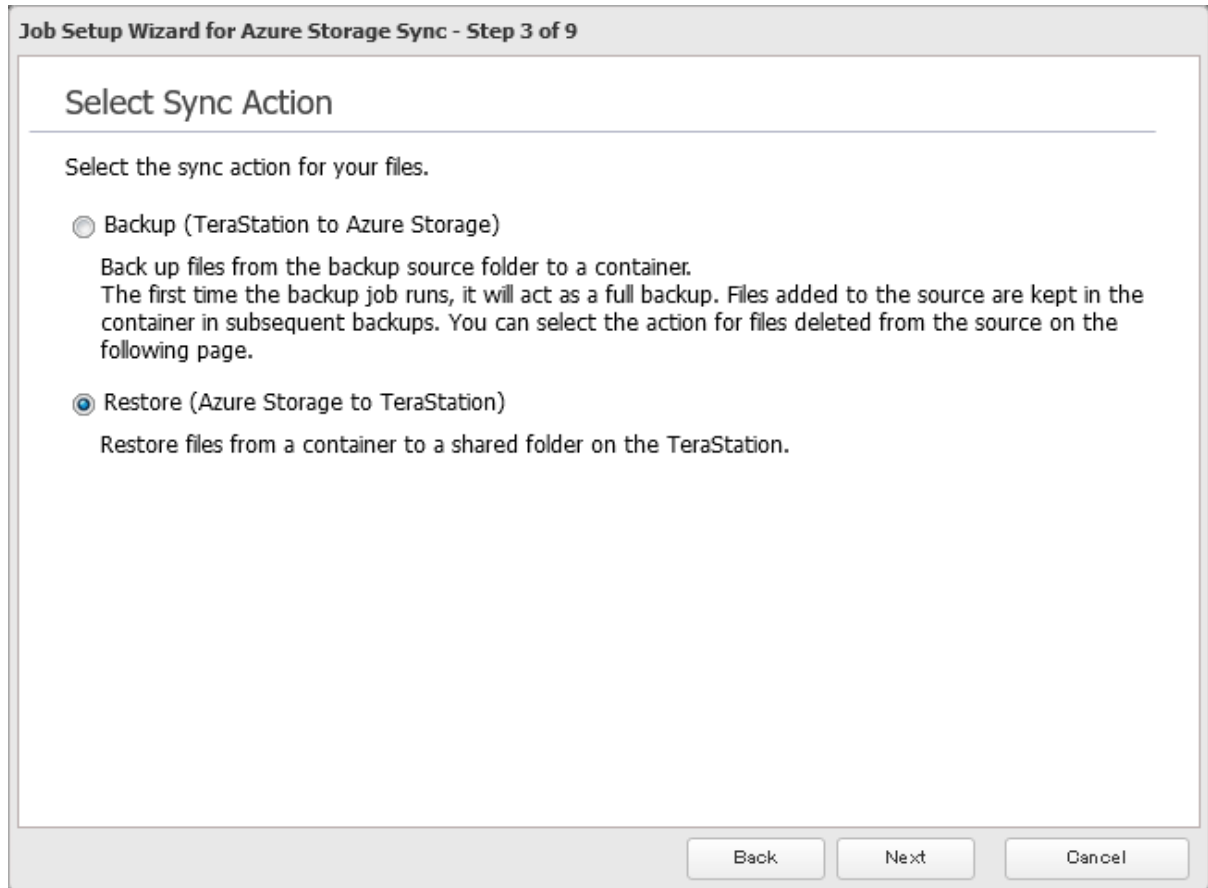

- 9** Enter the container name for the restore source and select the desired shared folder on the TeraStation as the restore destination, then click *Next*.

- 10** Select either to restore data into the first level folder (root folder) or the second level (subfolder) of the restore destination folder, then click *Next*.
- 11** Confirm that all settings are properly configured and click *OK*.
- 12** The process is complete once you close the confirmation window that appears.

Notes:

- When deleting a finished restore job, it can be converted to a backup job. If that restore job had been configured to restore to the second level of the shared folder, restored data will automatically be moved to the first level. If there are files with the same filename in the first level folder, those files will be overwritten.
- If restore fails due to insufficient free space, restore jobs will not start until manually resumed. To resume the job, click *Resume* on the job list window.

Changing Job Settings

Follow the procedure below to change any of the backup job settings you have already configured. Restore job settings cannot be changed.

- 1** From Settings, click *Cloud Storage*.

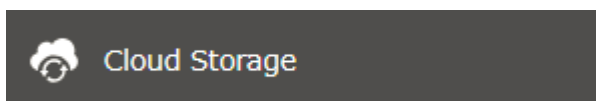

2 Click the settings icon () to the right of “Microsoft Azure Storage Sync”.



3 From the job list, click the job whose settings you want to change.

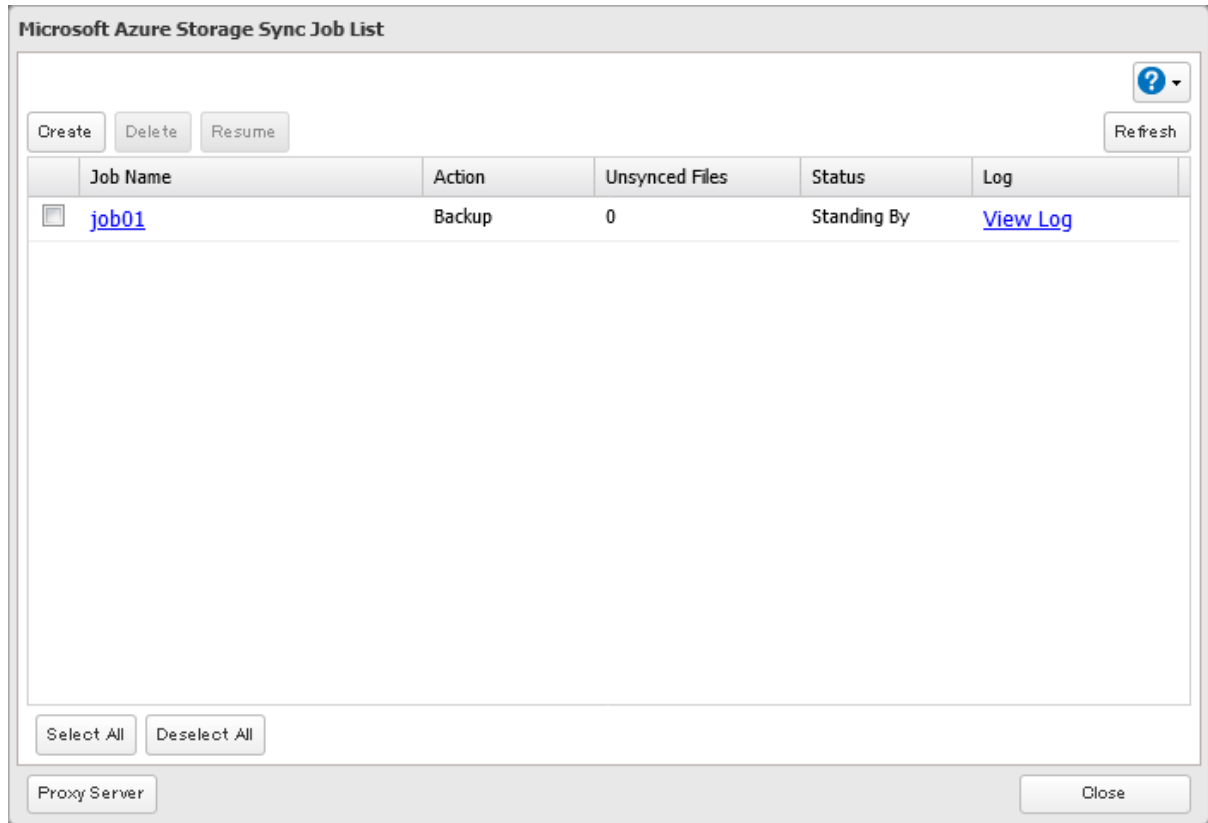

- 4** From the *Options* tab, click *Edit* and configure the desired settings, then click *OK*.

Azure Storage Sync Job Settings

Backup Interval: 5 minutes

Filter by File Size: Enable Disable

Maximum Size: 1 MB

Filter Hidden Files: Enable Disable

Filter by File Extension: Enable Disable

Filtered Extensions:

Extensions

OK Cancel

- 5** The process is complete once you close the confirmation window that appears.

Synchronizing with Microsoft OneDrive

The TeraStation supports synchronizing with Microsoft OneDrive, the online cloud storage service. Once linked, you can share files on the TeraStation via OneDrive (or files on OneDrive via the TeraStation). Follow the procedure below to configure your TeraStation for use with Microsoft OneDrive.

Notes:

- To use Microsoft OneDrive Sync, you will need a Microsoft account and an available empty OneDrive folder. If you don't have a Microsoft account, or if you need to create a OneDrive folder, refer to the Microsoft website.
- If using OneDrive through a proxy server, click *Proxy Server* and select whether to use the configured settings or configure an identical proxy server. If using an identical proxy server, select "New settings" and enter the proxy server name, port number, username, and password. Consult your network administrator for detailed proxy server settings.

Creating a OneDrive Sync Job

Follow the procedure below to create a new job.

- 1** From the Microsoft portal, create your Microsoft account before proceeding with the procedure.

2 From Settings, click *Cloud Storage*.

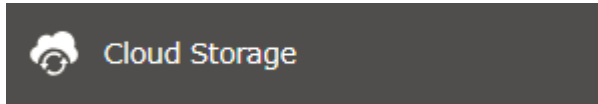

3 Move the OneDrive Sync switch () to the  position to enable OneDrive Sync.



4 Click the settings icon () to the right of "Microsoft OneDrive Sync".



5 Click *Create*.

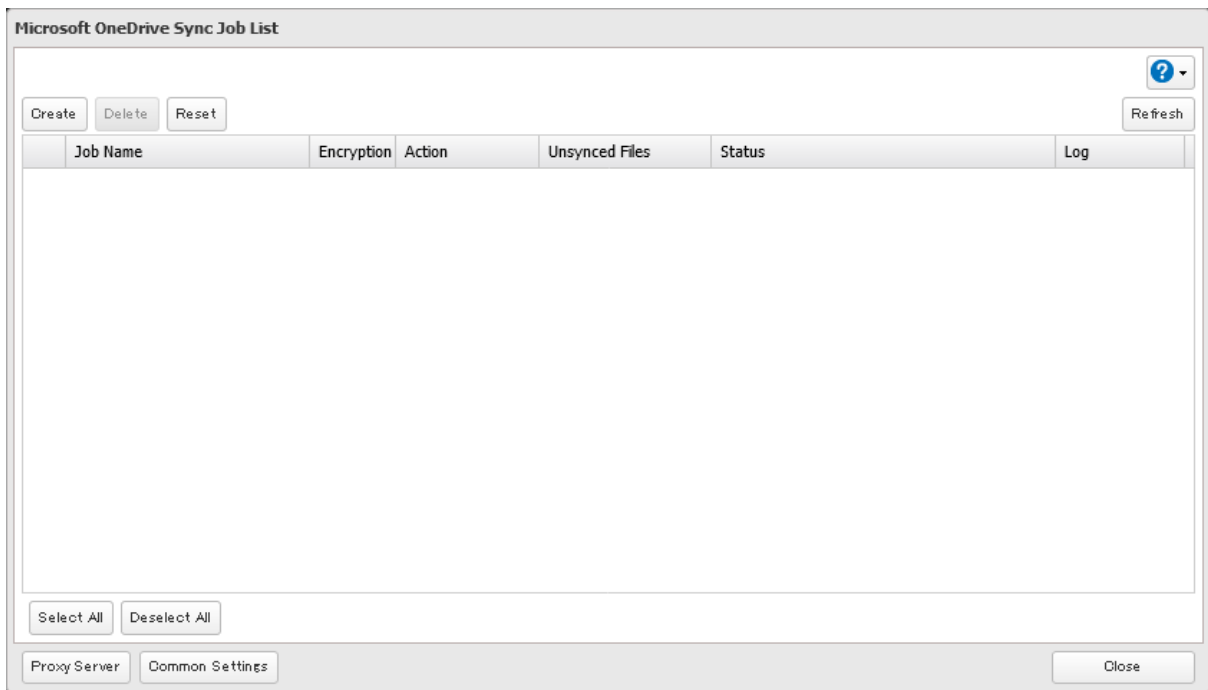

6 The sign-in window will open. Enter the username and password of your Microsoft account, then sign in.

7 Enter the desired job name and click *Next*.

Job Setup Wizard for OneDrive Sync - Step 1 of 10

Enter a Job Name

Enter a name for the job to be created.

 ?

- 8** Select the sync action and behavior for when files with the same name are already in the target folder, then click *Next*.

There are three types of sync actions: bidirectional, uploading, and downloading. If bidirectional is selected as the sync action, files on both OneDrive and the TeraStation will be updated. If uploading is selected as the sync action, only files on OneDrive will be updated. If downloading is selected as the sync action, only files on the TeraStation will be updated.

The behavior for when files with the same name already exist will apply if those files are changed on both the TeraStation and OneDrive.

Job Setup Wizard for OneDrive Sync - Step 2 of 10

Select Sync Action

Select the sync action for your files.

Upload

Files with Same Names

- Keep files on OneDrive
If there is a file conflict when syncing, files on OneDrive will be saved over other versions.
- Keep files on the TeraStation
If there is a file conflict when syncing, files on the TeraStation will be saved over other versions.
- Keep files with newer modified date
If there is a file conflict when syncing, files with the newer modified date will be saved over other versions.

Back Next Cancel

- 9 Select the desired TeraStation and OneDrive folders. Do not use a TeraStation shared folder that is currently being used for certain TeraStation functions such as cloud storage sync jobs, including existing OneDrive Sync jobs. If you want to create an empty folder first, click *Browse* under “Folder on TeraStation”, then click *Create Folder* on the selecting folder window that appears. Click *Next* after selecting the folders.

Job Setup Wizard for OneDrive Sync - Step 3 of 10

Configure Job Pairs

Select the OneDrive and TeraStation folders you want to sync data between.

Folder on TeraStation	onedrive	<input type="button" value="Browse"/>
Folder on OneDrive	OneDrive/Drive1/doc-test	<input type="button" value="Browse"/>

Note: The sixth level and deeper of shared and OneDrive folders cannot be selected.

- 10 Specify the sync interval and click *Next*. The sync process will occur sequentially after the specified interval of time has passed.

Job Setup Wizard for OneDrive Sync - Step 4 of 10

Configure Sync Interval

Select the interval of time between each synchronization occurrence.

60 minutes

Back Next Cancel

- 11** Configure the sync frequency. Files will be uploaded during the start and end times of the interval configured in step 10 above. If you want to always upload files during the configured sync interval, select "Always sync within the specified interval" for "Frequency". Click *Next* after configuring.

Job Setup Wizard for OneDrive Sync - Step 5 of 10

Configure Sync Frequency

Configure a sync frequency for a job. If you select "Daily", specify the start and end time. If you select "Weekly", specify the day of the week and times.

Frequency

Start Time

End Time

Day of Week
 Sunday Monday Tuesday Wednesday Thursday Friday Saturday

- 12** Select whether to encrypt the files using a password. When encryption is enabled, uploaded files will be archived in zip format and encrypted using the entered encryption password. Click *Next* after selections are finished.

Job Setup Wizard for OneDrive Sync - Step 6 of 10

Configure Encryption

Enable encryption for the files when uploading to OneDrive.

Enable Disable

Encryption Password

Setting an encryption password with 10 or more characters is recommended. The encryption password cannot be changed once it's configured. Make sure to manage the password carefully after it has been saved.

Back Next Cancel

Note: If the password contains spaces or backslashes (\), decrypting a file on a computer may fail.

- 13** Select whether to check for file consistencies and delete older files with the same name from OneDrive. Click *Next* after selections are finished.

Job Setup Wizard for OneDrive Sync - Step 7 of 10

Configure File Options

Consistency Check
Select whether to enable consistency checks. The hash values of files in the source and destination folders will be compared for uploading/downloading. If there are any inconsistencies between files, the system will try syncing again.

Enable Disable

Uploaded Files
Configure settings to delete old versions of files with the same name that have been uploaded onto OneDrive before an upload job starts to conserve space usage.

Delete old version Keep old version

Back Next Cancel

- 14** Configure whether to filter the sync target files. The following screen enables file filtering configuration by file sizes and whether they're hidden. The file size filter will only apply to uploads. The available maximum size is up to 15,360 MB (15 GB). "Hidden files" refer to files whose filename starts with a period. Click *Next* after selections are finished.

Job Setup Wizard for OneDrive Sync - Step 8 of 10

Configure File Filters 1

Configure the requirements for filtering files. If any files in the folder on either the TeraStation or OneDrive meet any of the following requirements, those files will not be synced.

Filter by File Size

Enable Disable

Maximum Size: MB

Filter Hidden Files

Enable Disable

Back Next Cancel

- 15** Configure whether to filter the sync target files. The following screen enables file filtering configuration by extensions. Click *Next* after selections are finished.

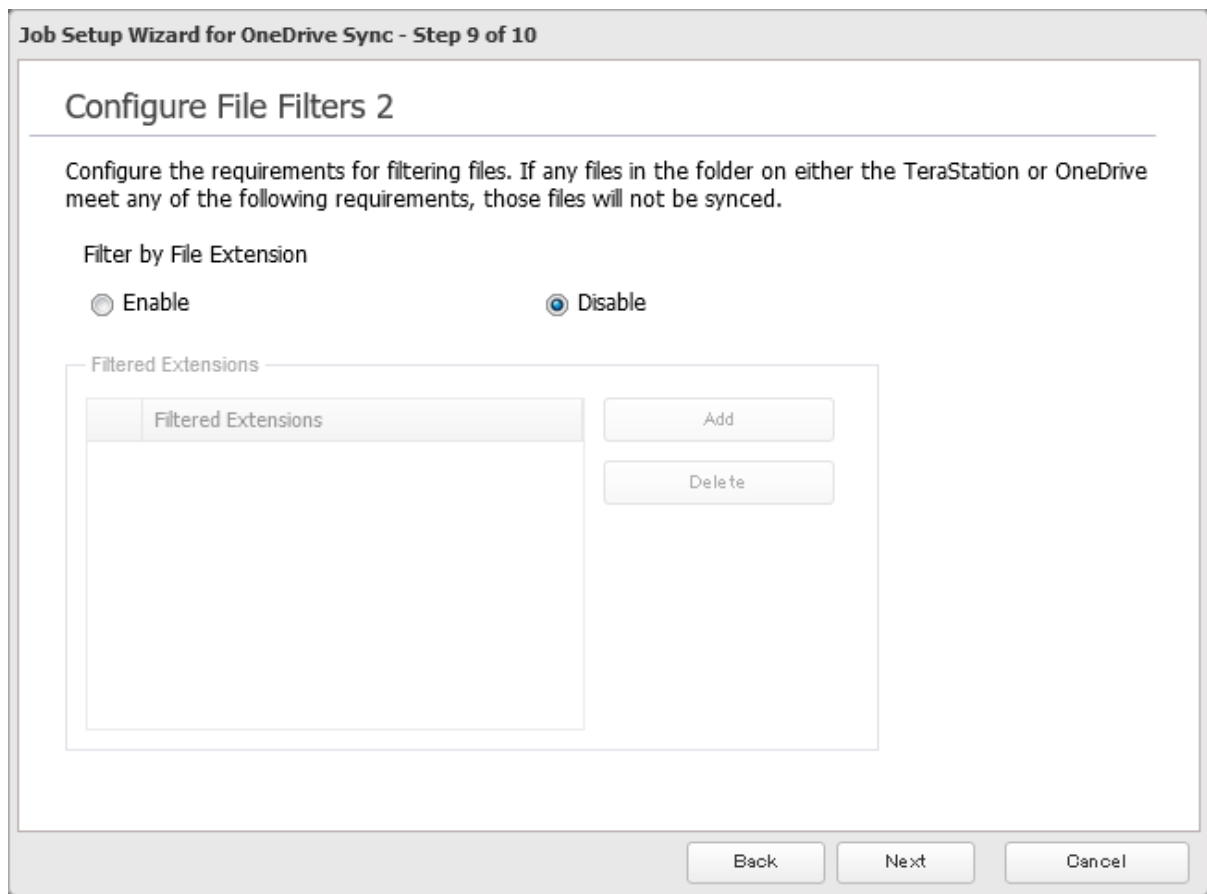

- 16** Confirm that all settings are properly configured and click *OK*.

- 17** The process is complete once you close the confirmation window that appears.

Notes:

- The following files or folders may not synchronize:

- Files or folders with names containing any of these symbols " # % & * / : > < ? \ } { ~
- Files or folders with names ending in a space or a period

If synchronization fails, check that the names of the unsynchronized files or folders meet the conditions above. When copying files or folders with the listed symbols from macOS to a TeraStation folder, their names may automatically be modified to remove the unsupported characters.

- Depending on your network environment, you may be unable to upload or download larger files. To prevent this issue, divide a larger file into smaller files or compress the files to a smaller size before uploading them to OneDrive.
- When files are uploaded from the TeraStation folder using OneDrive Sync and then downloaded onto a computer from OneDrive, time stamps for files may be changed to the download date.
- When synchronizing files, if there are nine or more jobs created, the TeraStation will re-arrange any running jobs to reduce the load.
- Do not copy 100,000 or more files to the TeraStation folder at once. If you do and synchronization fails, try again with fewer files.
- If a file's size is zero bytes, a sync error will occur and the file will not be synchronized. The I64 message will appear as a notification.

- If unexpected behaviors occur during file sync, such as some files not being synced, click *Reset* on the job list window. This will resync all files on the TeraStation and/or OneDrive the next time the sync process runs. The existing files will be overwritten, and files that will be resynced will vary depending on the sync action settings. To start resyncing immediately after clicking *Reset*, change the frequency settings to “Always sync within the specified interval” by referring to the [“Changing Job Settings”](#) section below.

Changing Job Settings

Follow the procedure below to change any job settings you have already configured.

- 1 From Settings, click *Cloud Storage*.

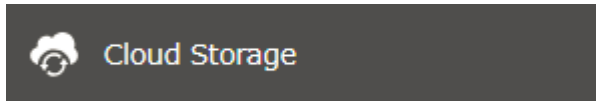

- 2 Click the settings icon () to the right of “Microsoft OneDrive Sync”.



- 3 From the job list, click the job whose settings you want to change.

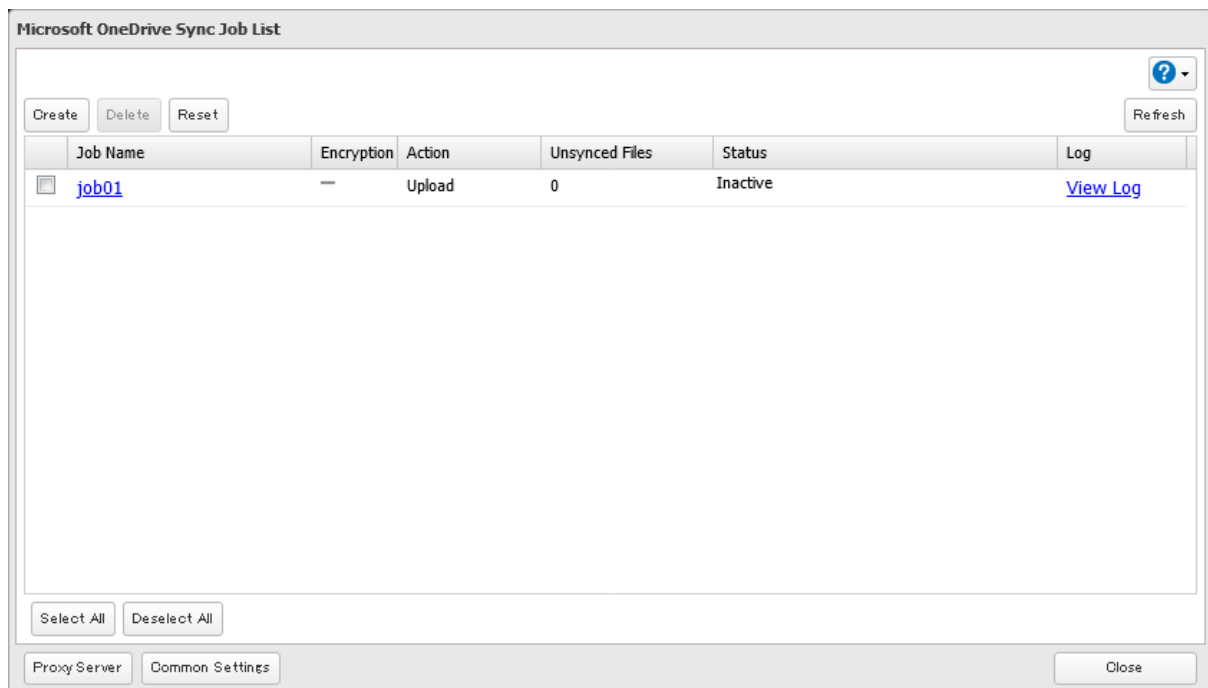

4 From the *Options* tab, click *Edit* and configure the desired settings, then click *OK*.

5 The process is complete once you close the confirmation window that appears.

Corrective Actions for in Case of Error

Error Appears in the “Status” Field of Job List

If any of the following messages appear in the “Status” field of the job list, the synchronization process did not complete properly. In such a case, try the corresponding corrective action.

Message	Description	Corrective Action
Some files were not synced due to OneDrive sync restrictions	There are some files that could not be synced because they meet certain OneDrive restriction conditions that exclude them from the sync target.	Delete the corresponding files from the sync folder.
Some files were not uploaded due to TeraStation sync restrictions	There are some files that could not be uploaded because they meet certain TeraStation restriction conditions that exclude them from the upload target.	Delete the corresponding files from the upload source folder.
Some files were not downloaded due to TeraStation sync restrictions	There are some files that could not be downloaded because they meet certain TeraStation restriction conditions that exclude them from the download target.	Delete the corresponding files from the download source folder.

Message	Description	Corrective Action
Failed in the past	There are some files that could not be synced.	Unsynced files will be synchronized in a subsequent job. To sync immediately, click <i>Reset</i> .
Token error	An error occurred on a token.	<p>Update the token by following the procedure below.</p> <ol style="list-style-type: none"> 1 From Settings, click <i>Cloud Storage</i>. 2 Click the settings icon () to the right of "Microsoft OneDrive Sync". 3 From the job list, click the job with the occurring token error. 4 Click <i>Update Token</i> at the bottom-left of the window. 5 Click <i>Reset</i> after the token update process finishes. 6 The process is complete once you close the confirmation window that appears.

Error Appears While Creating a Job or Error Code Appears on the Error Log

When creating OneDrive Sync jobs, you may see error messages with the following error codes. The error log may contain these codes as well. If you encounter any of the following error codes, refer to the table below and try the respective corrective action. If the error code is not listed on the table, refer to the Microsoft website instead: <https://docs.microsoft.com/en-us/onedrive/developer/rest-api/concepts/errors?view=odsp-graph-online>.

Code	Description	Corrective Action
access_denied	Access denied for the requested information.	To link with OneDrive, please consent to the request from OneDrive.
server_error	The authentication server encountered a temporary error.	Please wait for about 10 minutes and try again.
temporarily_unavailable	The authentication server is too busy.	Please wait for about 10 minutes and try again.
authcode_notfound	The authentication server is too busy.	Please wait for about 10 minutes and try again.
auth_server_error	The authentication server encountered a temporary error.	The authentication server will recover within UTC 12:00 midnight–8:45 a.m. (Mon–Fri). Please wait until it recovers.
auth_server_maintenance	The authentication server is currently undergoing maintenance.	Maintenance will finish within UTC 12:00 midnight–8:45 a.m. (Mon–Fri). Please wait until maintenance finishes.
activityLimitReached	There are too many requests so data could not be synchronized.	Check that the same Microsoft account is used on another Buffalo NAS device or Microsoft software. This error may be resolved by reducing the maximum number of threads per job on the window that appears by navigating to the job list and then clicking <i>Common Settings</i> .

Code	Description	Corrective Action
invalidRequest	A zero-byte file was going to be synchronized but failed.	Remove the zero-byte file and try again. If the I64 message persists on the Dashboard in Settings, click <i>Clear</i> to delete the message.
network_error	Could not register the authentication code.	Check that the network or proxy server settings are correct.
Unexpected error	An unknown error occurred.	Please wait for about 10 minutes and try again.

WebAccess

WebAccess is a software utility for accessing the files in the shared folder of your TeraStation from your computer or mobile devices through the Internet. **Be careful when configuring WebAccess. Certain settings can make the files in the shared folder available to anyone on the Internet, without any access restrictions.**

Note: WebAccess supports downloading up to 60,000 files at a time. Attempting to download 60,000 or more files at a time may result in unexpected behavior.

Configuring WebAccess

- 1 From Settings, click *File Sharing*.

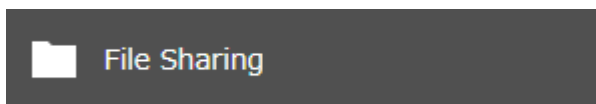

- 2 Click the settings icon () to the right of "WebAccess".



3 Click *Edit* and configure the desired settings, then click *OK*.

- To use SSL encryption for more secure data transfers, enable “HTTPS/SSL Encryption”.
- You may use the BuffaloNAS.com server as a DNS server, or disable it to use a different DNS server.
- Choose a “BuffaloNAS.com Name” and “BuffaloNAS.com Key” for your WebAccess account. Names and keys may contain between 3 and 20 alphanumeric characters, underscores (_), and hyphens (-).
- If UPnP is not enabled on your network, you will only be able to access your NAS device from the local network. To use WebAccess from outside your home, reconfigure WebAccess by referring to the [“Unable to Successfully Configure WebAccess”](#) section below.
- If “Exclusive Session” is enabled, multiple users cannot be logged in to WebAccess at the same time. Only the last login will be active.
- For “Session Timeout”, enter a time in minutes (1 to 120, or select “Unlimited”) before inactive users are logged out of WebAccess.

4 Move the WebAccess switch () to the position to enable WebAccess.



5 Click the settings icon () to the right of “Folder Setup”.



6 Click *Create*.

For best results, create a new dedicated share for WebAccess to prevent opening files accidentally.

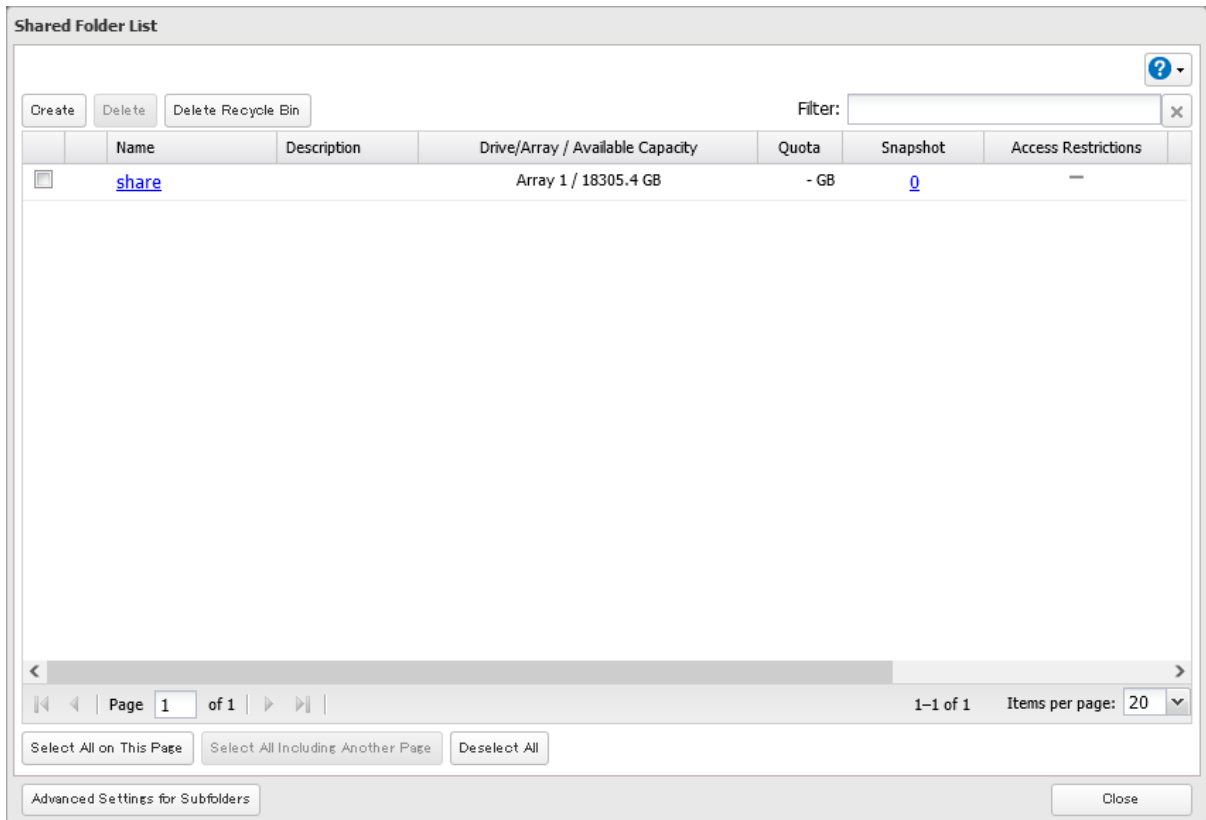

Note: When accessing shared folders through WebAccess from a remote location, a username and password may be required for certain operations. For best results, create a user account with permissions on the WebAccess share prior to use.

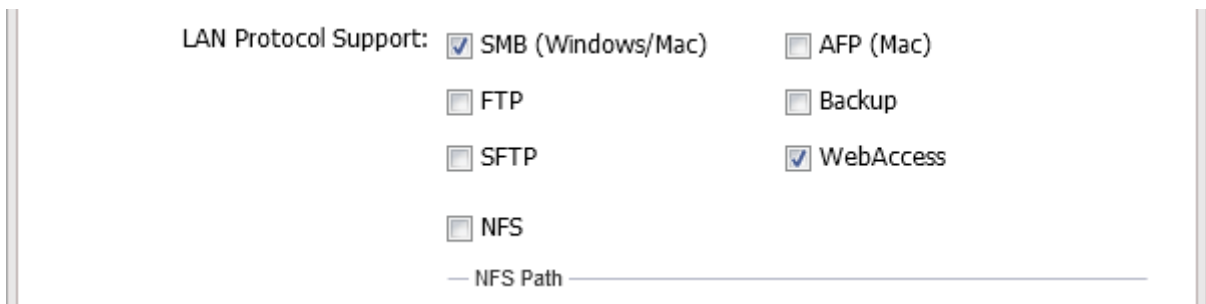
7 Under "LAN Protocol Support", select the "WebAccess" checkbox on the *Basic* tab.**8** Click the *Option 2* tab.

- 9 Select the desired WebAccess security level for “WebAccess Permissions”. For more detailed information about each WebAccess security level, refer to the note below.

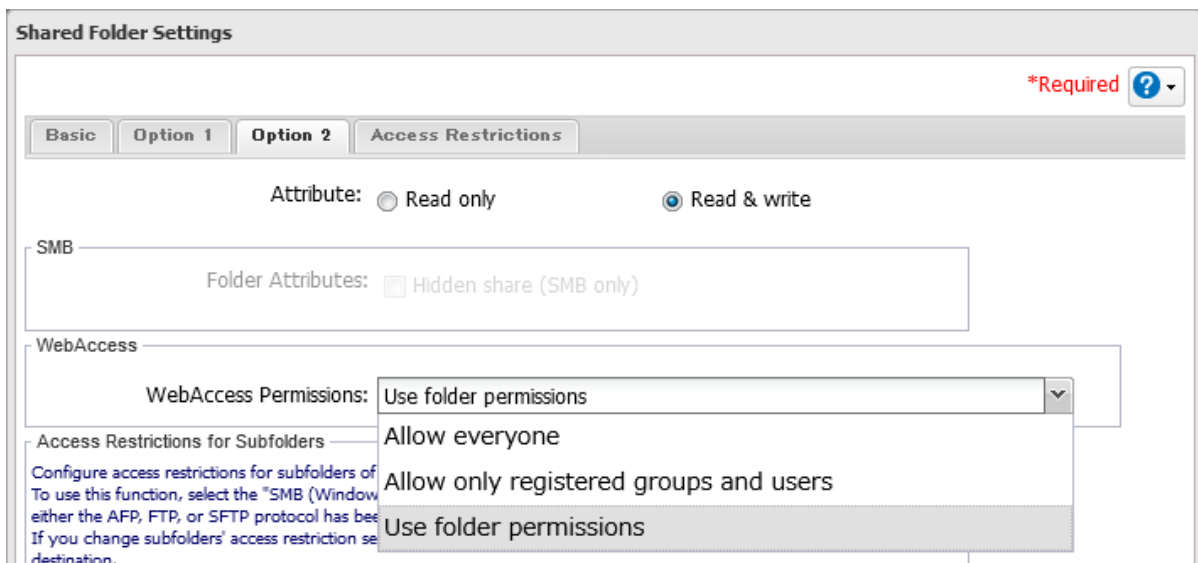

- 10 Configure other settings such as a folder name and click *OK*.

- 11 The process is complete once you close the confirmation window that appears.

Note: Whether a user or group can access a folder through WebAccess depends on a combination of WebAccess settings and the shared folder’s settings.

Allow everyone: Anyone can access (view) shared folders. (Access restrictions configured for shared folders will not work.)

Allow only registered groups and users: All groups and users registered on the Buffalo NAS device can use WebAccess. (Access restrictions configured for shared folders will not work.)

Use folder permissions: Users and groups have the same access permissions with WebAccess that they do locally. If access restrictions are not set for the shared folder, then this option will not be shown.

WebAccess permissions	Logged-in user permissions			
	Not logged in	No access	Read-only	Read and write
Allow everyone	R	R/W	R/W	R/W
Allow only registered groups and users	-	R/W	R/W	R/W
Use folder permissions	-	-	R	R/W

R/W: Read and write, R: Read-only, -: No access

Accessing via WebAccess

There are many ways to access WebAccess folders depending on your device:

For iOS or iPadOS Devices

To access from an iOS or iPadOS device, install the “WebAccess i” app for an iOS device or the “WebAccess i HD” app for an iPadOS device from the App Store. Refer to the app’s help guide for more detailed information on using the app.

For Android Devices

To access from an Android device, install the “WebAccess A” app from Google Play. Refer to the app’s help guide for more detailed information on using the app.

For Computers

Use a web browser on a computer; supported browsers include Microsoft Edge, Firefox, Google Chrome, Internet Explorer 9 or later, Safari 9 or later. Refer to the help guide at the BuffaloNAS.com website after connecting with your BuffaloNAS.com name for more detailed information.

Unable to Successfully Configure WebAccess

WebAccess configuration may not succeed if UPnP is disabled on your router. If this occurs, try the following procedure.

- 1 From Settings, click *File Sharing*.

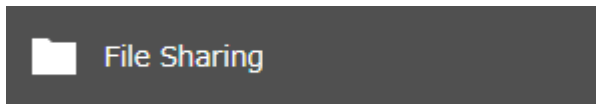

- 2 Click the settings icon () to the right of "WebAccess".



- 3 Click *Edit*, then enable "Access via BuffaloNAS.com Server" and enter the desired BuffaloNAS.com name and key.

 A dialog box titled "WebAccess Settings" with a close button (X) in the top right corner. The settings are as follows:

- HTTPS/SSL Encryption: Enable Disable
- Access via BuffaloNAS.com: Enable
- Server:
 - BuffaloNAS.com Name *:
 - BuffaloNAS.com Key *:
 -
- Disable
- Other DNS Service Hostname *:
- UPnP: Enable Disable
- External Port *:
- NAS Internal Port *:
- Exclusive Session: Enable Disable
- Session Timeout *: minutes Unlimited

 At the bottom, there is a "LAN Only" button on the left, and "OK" and "Cancel" buttons on the right.

- 4 Disable "UPnP" and enter a router's port number into the "External Port" field, then click *OK*.

- 5 Move the WebAccess switch () to the  position to enable WebAccess.



- 6 After configuring the required settings on the Buffalo NAS device is finished, next configure the router using the port number set at step 4 above.

FTP

By default, the TeraStation's shares are only accessible by users connected to the same network or router as the TeraStation. The optional FTP server allows users outside the local network to access the TeraStation.

Note: FTP is intended for users who already have FTP client software and have experience with it.

Enabling FTP

Follow the procedure below to enable FTP service to allow access via FTP connections.

- 1 From Settings, click *File Sharing*.

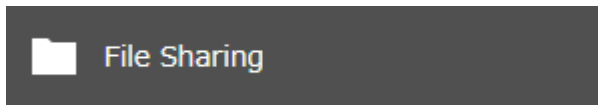

- 2 Move the FTP switch () to the  position to enable FTP.



- 3 Click the settings icon () to the right of "Folder Setup".



4 Choose a folder to enable remote FTP access on.

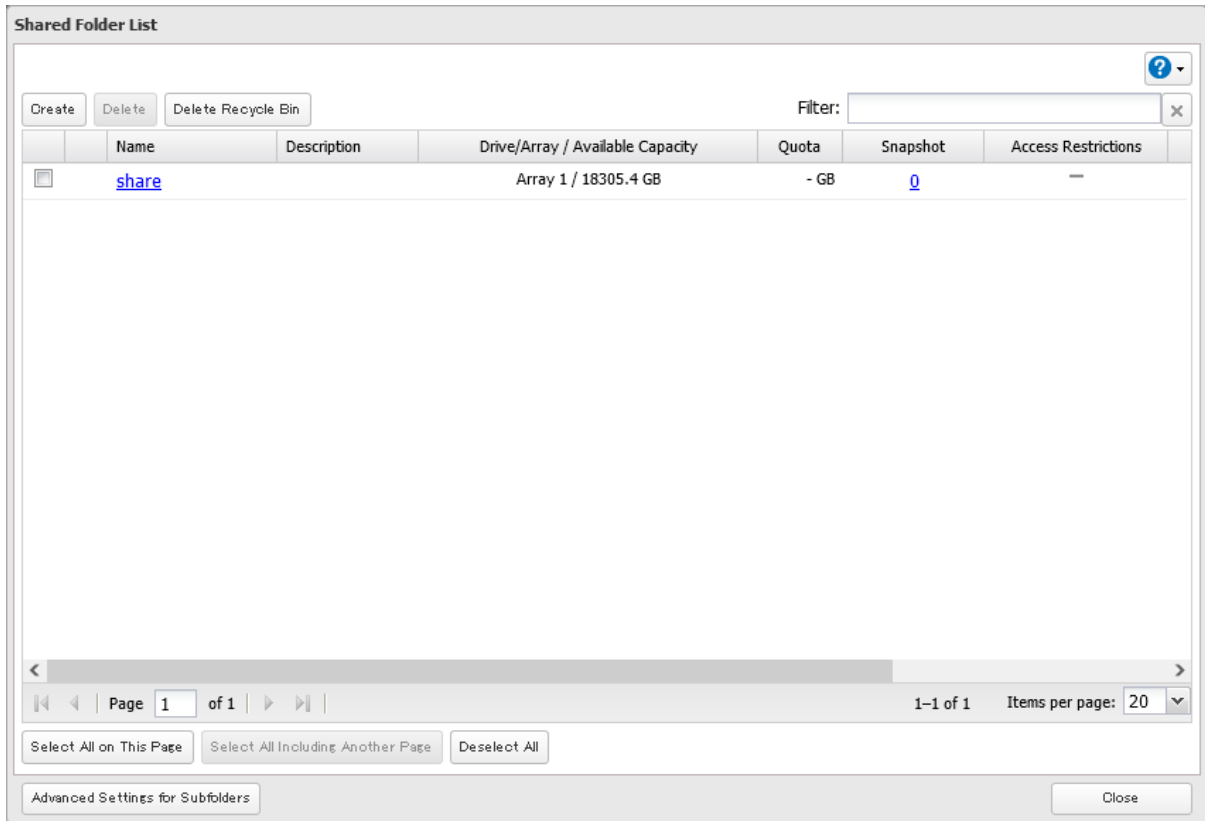

5 Under "LAN Protocol Support", select the "FTP" checkbox on the *Basic* tab; select read-only or read and write for the shared folder's attribute on the *Option 2* tab and click *OK*.

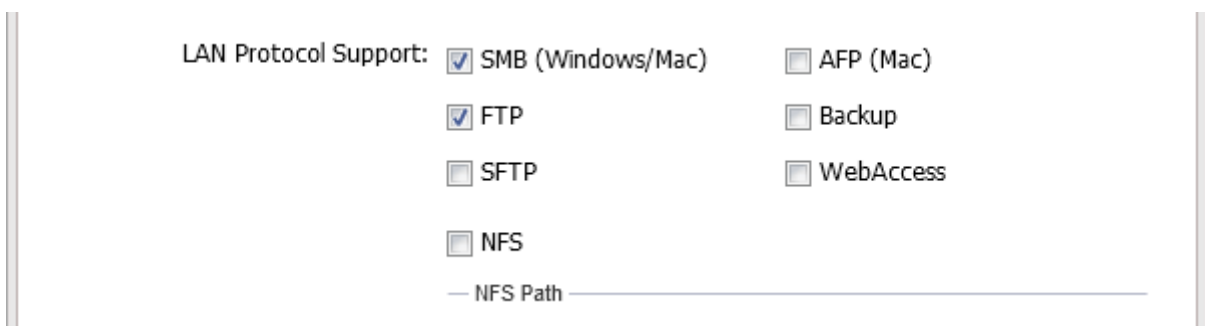

6 The process is complete once you close the confirmation window that appears.

Accessing the TeraStation with an FTP Client

Accessing as a Registered User

To access the TeraStation via FTP, configure your FTP client software with the following settings:

- Hostname: IP address of the TeraStation
- Username: the TeraStation's username
- Password: the TeraStation's password
- Port: 21

Accessing as an Anonymous User

To allow anonymous access to your FTP share, disable access restrictions. Configure your FTP client software with the following settings for anonymous FTP access:

- Hostname: IP address of the TeraStation

- Username: "Anonymous"
- Password: any character string
- Port: 21

Notes:

- If the TeraStation joins a domain, anonymous users cannot remote access via FTP.
- Shared folders connected by FTP are available from the "/mnt" folder. Examples of default locations are:
 - /mnt/array1/share
 - /mnt/disk1/share
 - /mnt/usbdisk1
- If a file was created or copied using AFP, you may be unable to delete it using an FTP connection. If this occurs, use an SMB or AFP connection instead to delete the file.
- For FTP connections, make sure that the total filename length including the folder path is 250 single-byte characters or fewer.

Chapter 8 Security Enhancement

Two-Factor Authentication

Two-factor authentication is a security feature that strengthens login security by requiring a verification code in addition to username and password to log in to Settings. Two-factor authentication can better protect both your login credentials and data on the TeraStation.

Enabling Two-Factor Authentication

Notes:

- To enable two-factor authentication, enable email notification first. Refer to the [“Email Notification”](#) section in chapter 11 for the detailed procedure.
- Two-factor authentication requires an authenticator app to be installed onto your mobile device. The following authenticator apps are supported:
 - Google Authenticator
 - Microsoft Authenticator
 - Duo Mobile
 - Twilio Authy

1 From Settings, click *File Sharing*.

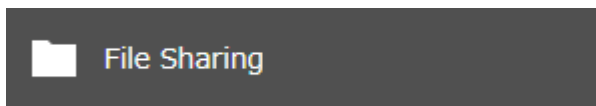

2 Click the settings icon () to the right of “Users”.



3 Select the logged-in user for whom two-factor authentication will be enabled.

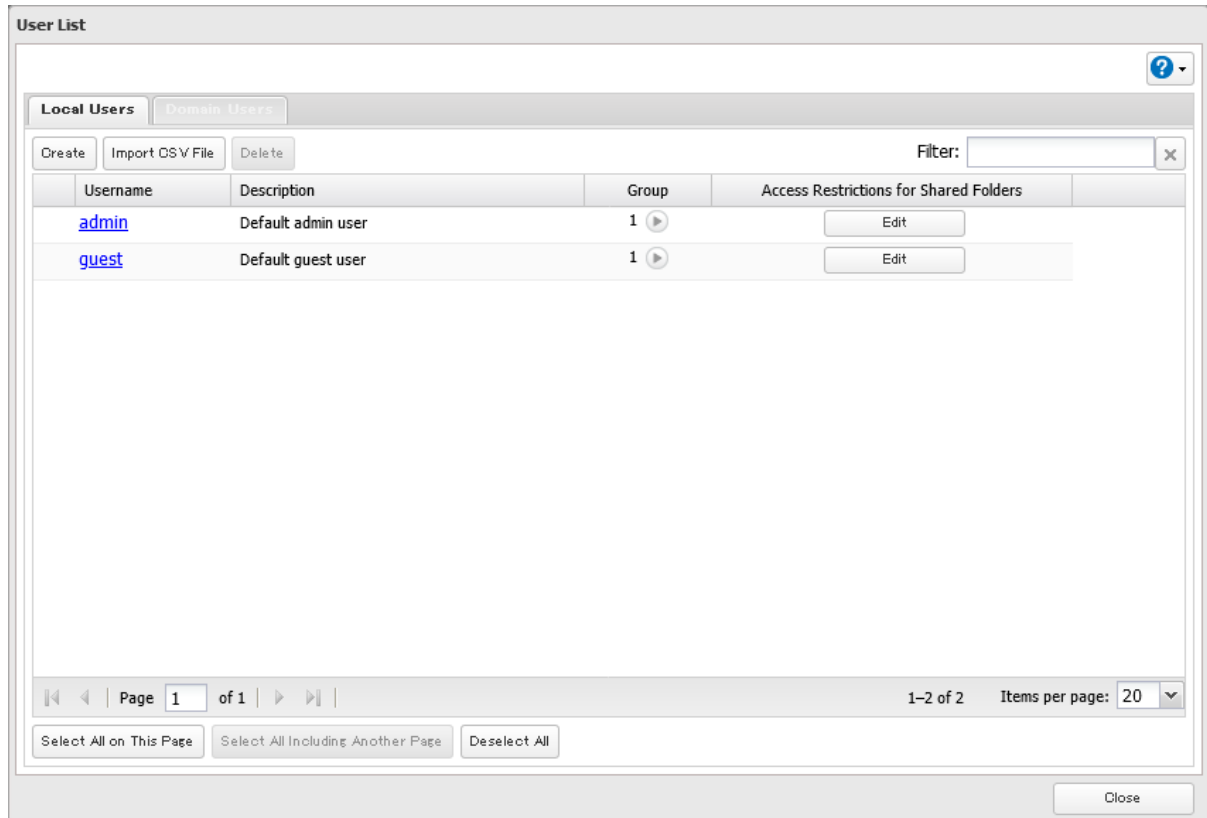

4 Click Two-Factor Authentication.

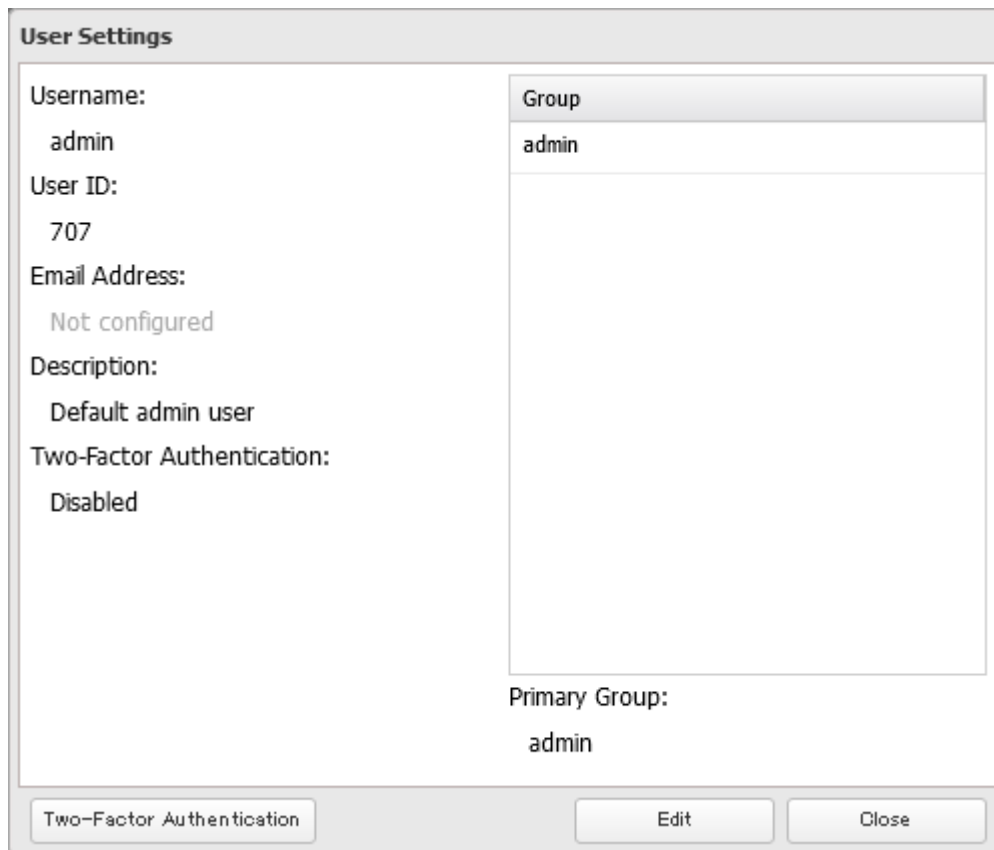

5 Click *Next*.

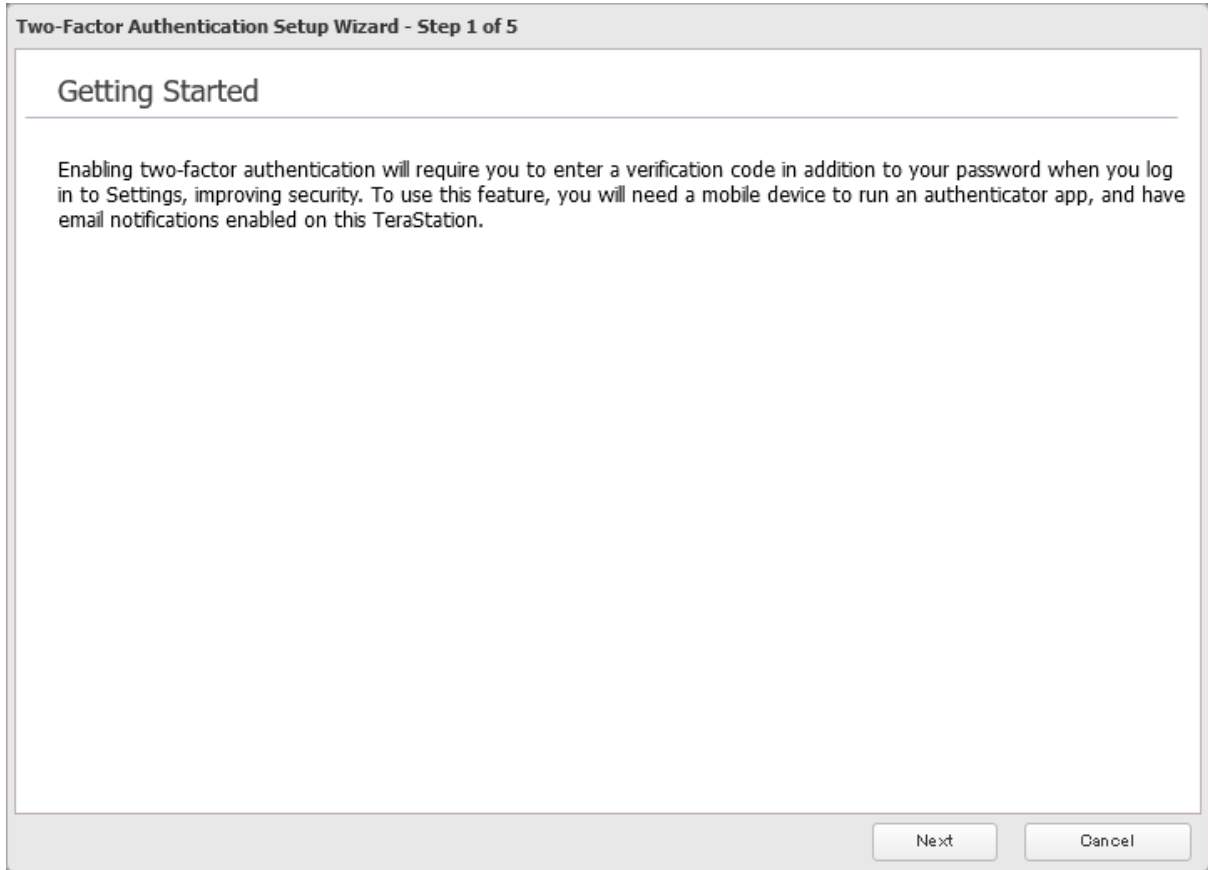

- 6 Enter an email address as an alternative method to receive the verification code and click *Next*.
Click *Send Test Email* to have a test email sent to the entered address to confirm that the address is correct.

Two-Factor Authentication Setup Wizard - Step 2 of 5

Configure Email Address for Verification Code

Set the email address to which the verification code will be sent if authentication fails through the app. After entering the email address, click 'Send Test Email' to confirm that the entered email address is correct.

Email Address

Note: The entered email address will be assigned to a user. If another email address had already been assigned to the user, it will be changed to the entered email address instead. The email address can be changed from the user settings page.

- 7 Open the installed authenticator app on your mobile device.

- 8 Use the authenticator app to scan the QR code displayed in Settings. Alternatively, enter the setup key into the app. Click *Next* after the app establishes the connection with the TeraStation.

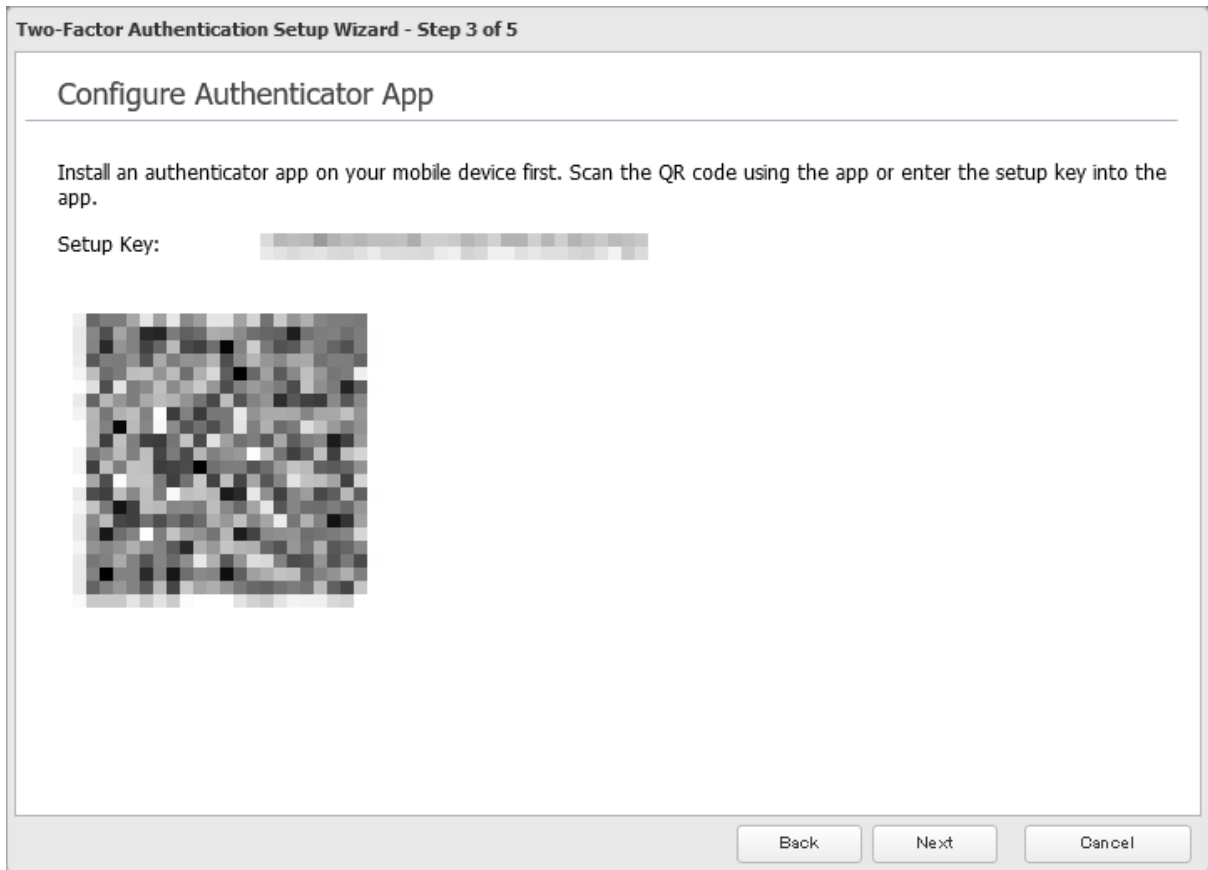

- 9 Enter the 6-digit verification code displayed on the authenticator app and click *Next*.

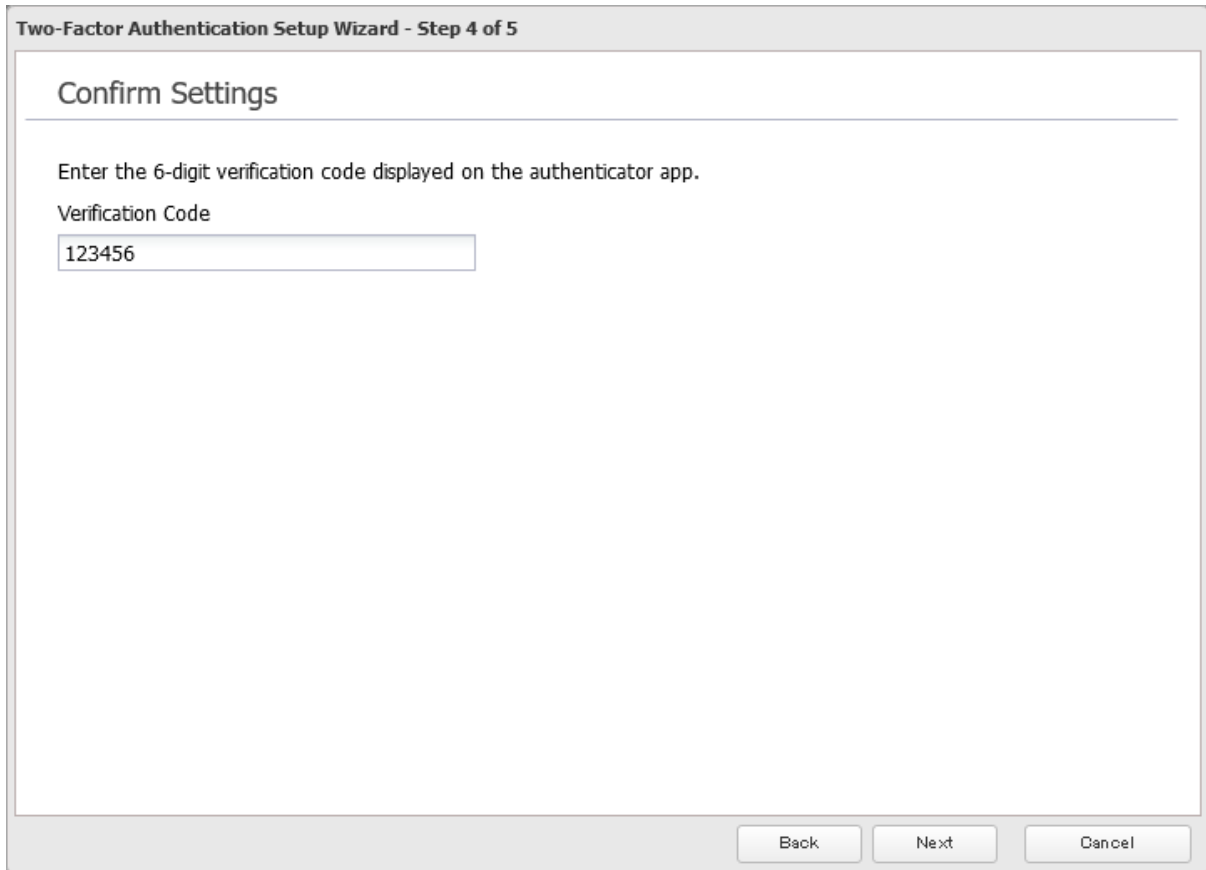

- 10 The process is complete once you close the wizard window that appears.

Two-factor authentication will become active after logging out from Settings. A verification code will be required the next time you log in to Settings using the same username.

Note: If authentication fails even if the verification code is valid, make sure the time settings on both the TeraStation and the mobile device are the same.

Restricting Logins for Non-Admin Users

You can restrict users who do not have administrator privileges from being able to log in Settings.

- 1 From Settings, click *File Sharing*.

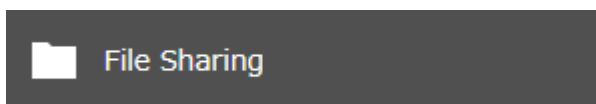

- 2 Click the settings icon (⚙️) to the right of "Users".



3 Select a user from the user list.

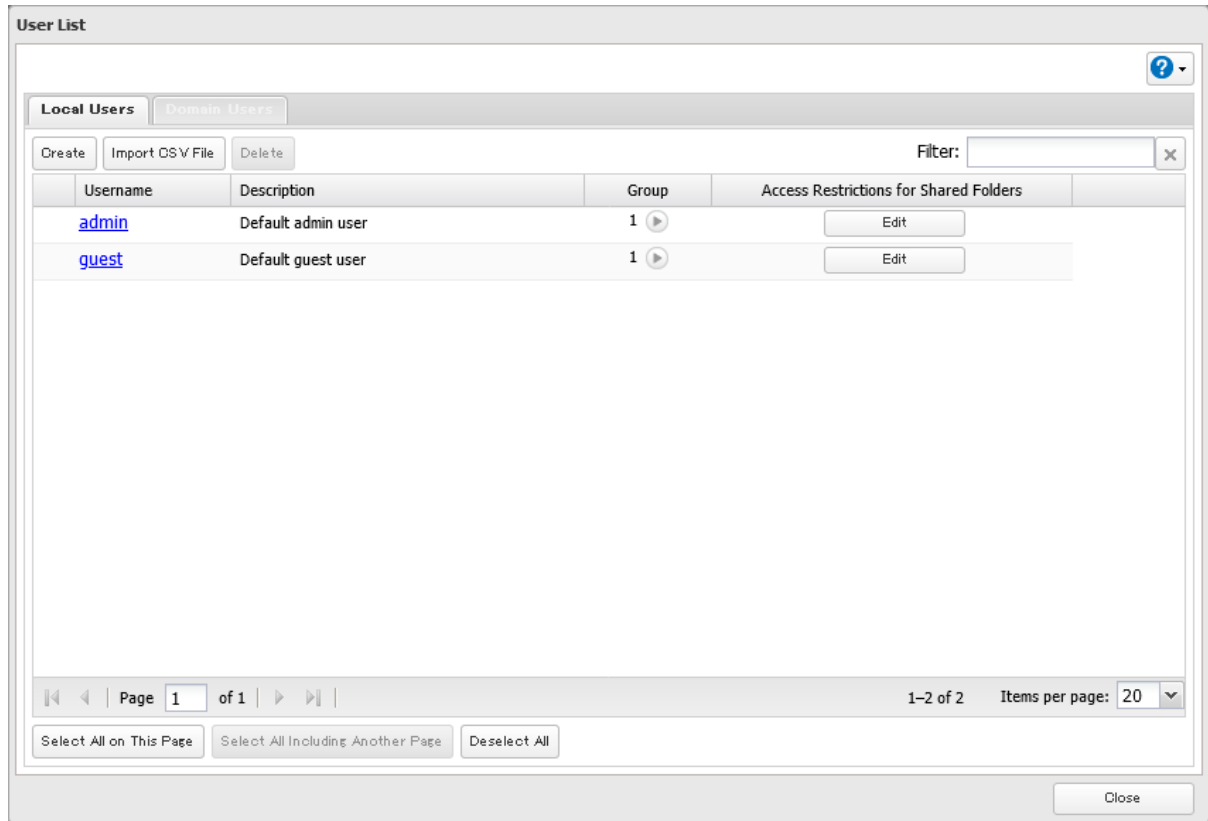

4 Click *Two-Factor Authentication*.

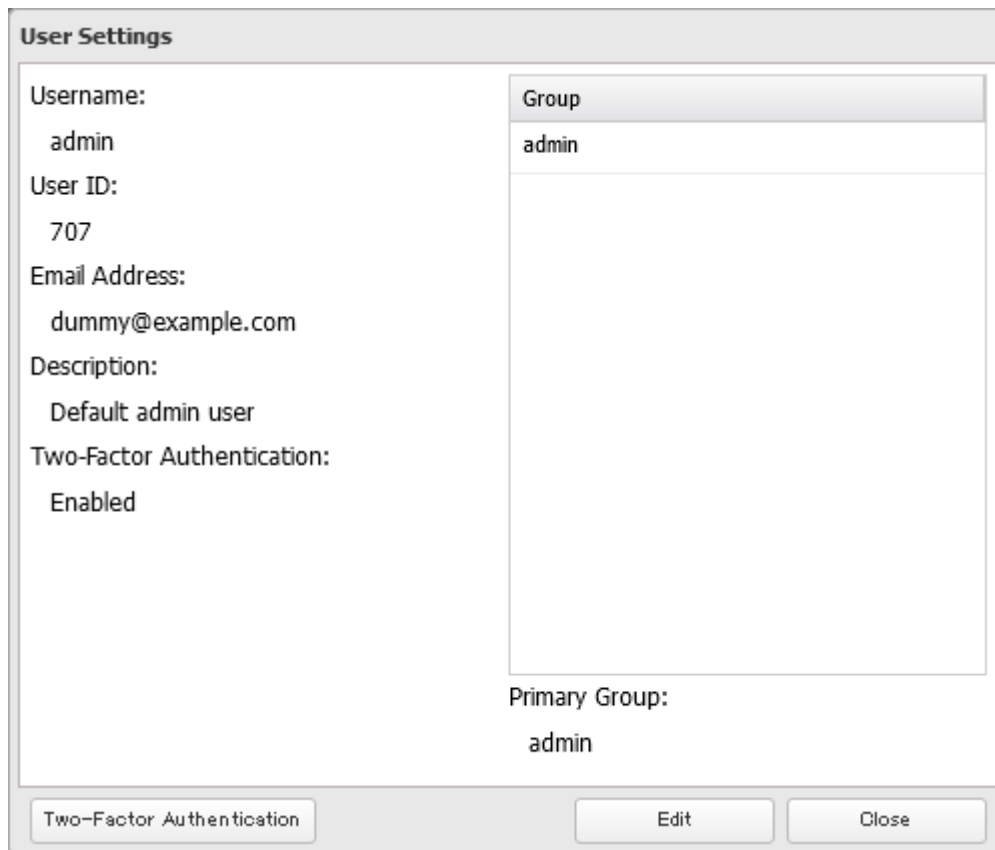

5 Change the “Settings Interface Access” option to “Deny login by non-administrator users”, then click *OK*.

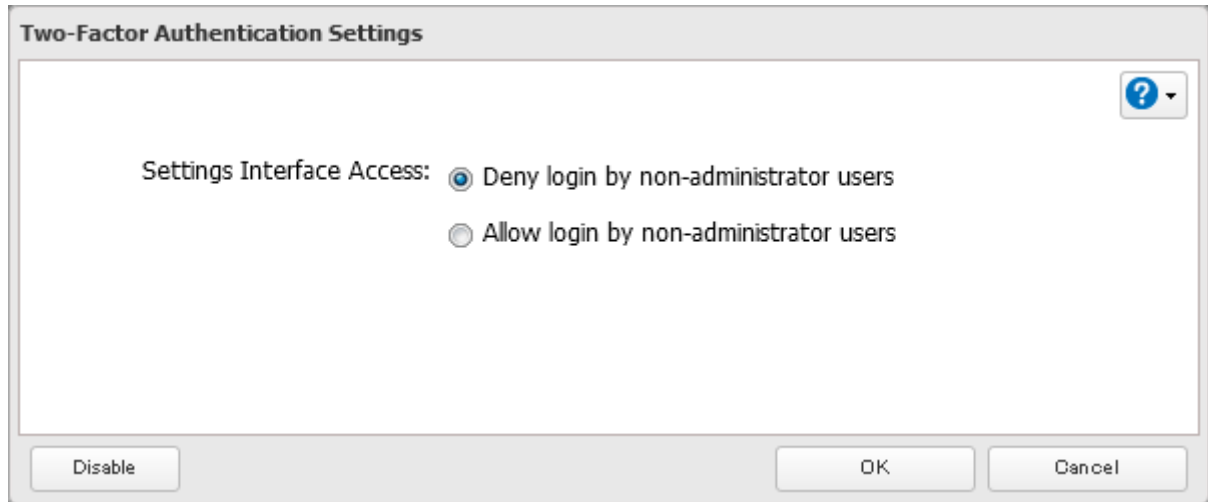

6 The process is complete once you close the confirmation window that appears.

Disabling Two-Factor Authentication

1 From Settings, click *File Sharing*.

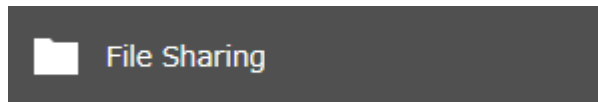

2 Click the settings icon () to the right of “Users”.



3 Select the logged-in user for whom two-factor authentication will be disabled.

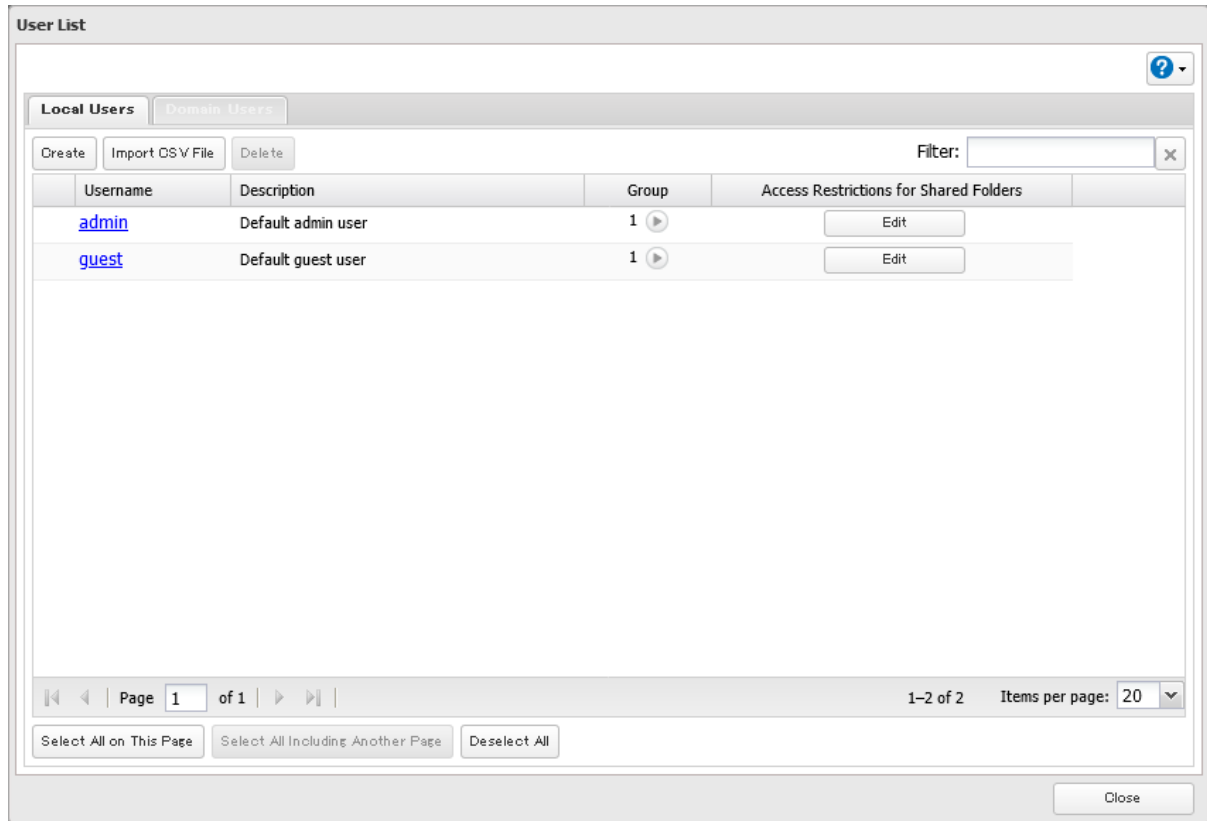

4 Click *Two-Factor Authentication*.

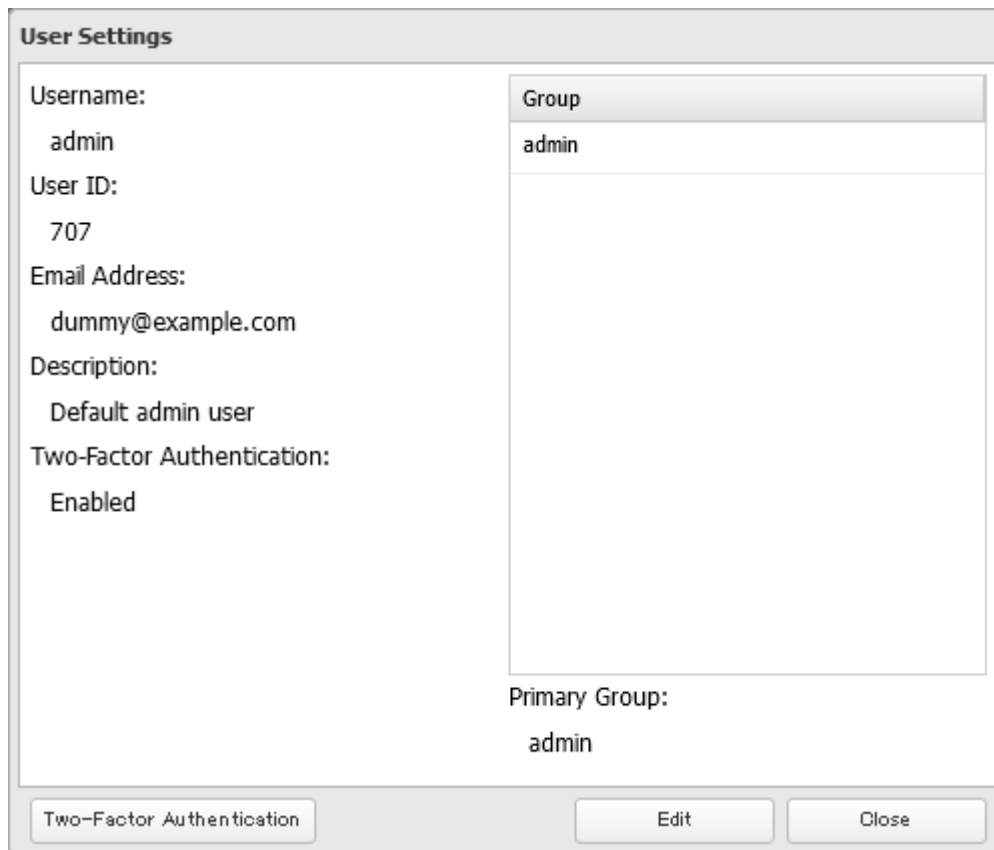

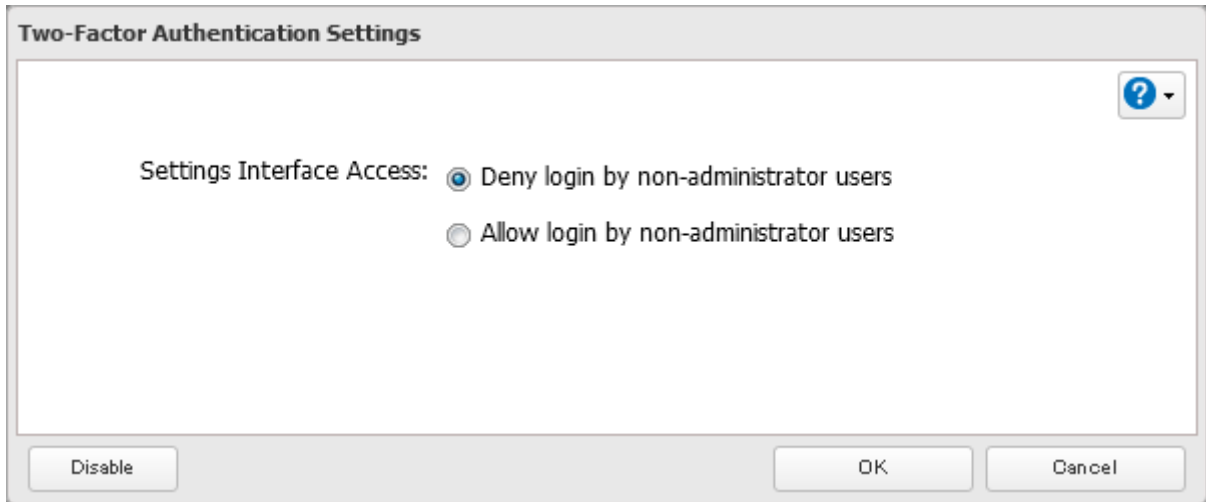
5 Click *Disable*.**6** The process is complete once you close the confirmation window that appears.

Encrypting Data Transmission

Encrypting Settings Data

All communication with Settings can use SSL encryption if you access the Settings page by changing “http://” to “https://” in the browser address bar or click *Secure Connection* from the login window. Once you are logged in using the HTTPS connection and wish to disable SSL encryption, click *Normal Connection* from the login window.

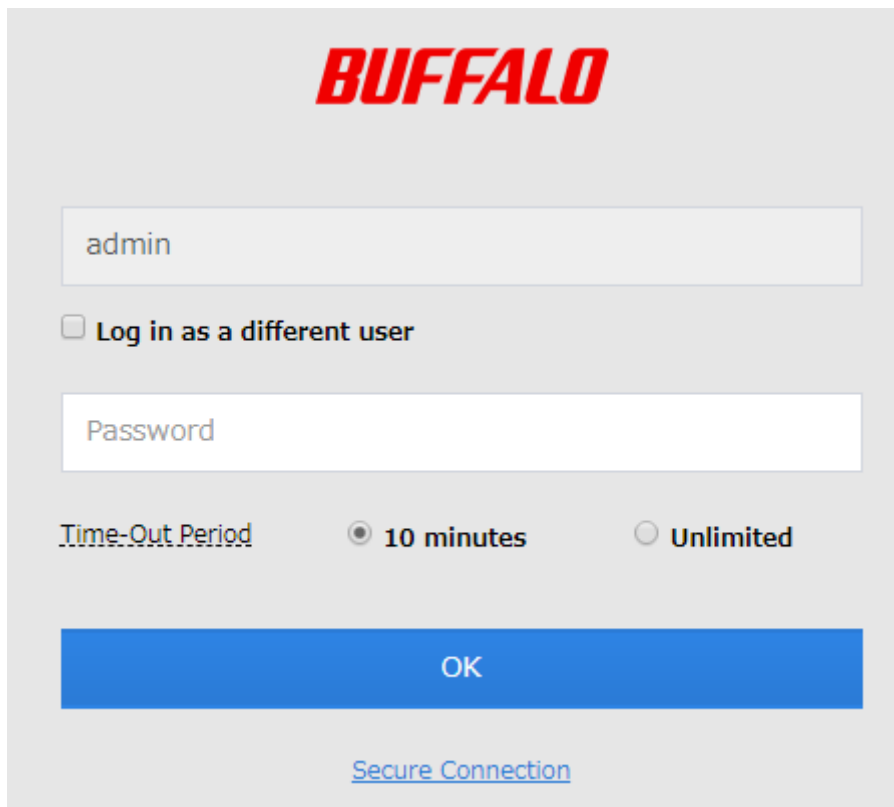

Encrypting FTP Transfer Data

You can encrypt passwords using SSH for secure FTP communication. First, open a shared folder's settings; under "LAN Protocol Support", select the "SFTP" checkbox on the *Basic* tab and click *OK*. Also, you have to enable the SFTP service by moving the SFTP switch to the **on** position on "File Sharing".

Notes:

- If SFTP is enabled, guest users and anonymous users will not be able to access shared folders.
- If the TeraStation joins a domain, local users cannot remote access via SFTP.

SSL

SSL (Secure Socket Layer) is a protocol that uses a public key encryption system to establish secure communication channels between networked devices, allowing for encrypted Internet traffic and server identity verification. The SSL protocol uses a pair of keys – one private, one public – to authenticate and manage secure connections. SSL keys are used during setup screen operations and FTP communication.

SSL Key Formats/Extensions

The SSL keys may include the following encoding formats and extensions:

SSL Certificate (server.crt)

The server.crt is the server public key, and is generated by the TeraStation. A computer that receives the server.crt uses it to encrypt data, and the TeraStation then uses the server.key file to decrypt the data.

In SSL, this key contains the server certificate, and depending on your computer environment, a check may be performed to determine the trustworthiness of the certificate. The server certificate included in the TeraStation's default settings was created by Buffalo, and in some cases, the security certificate warning message may appear in your browser or another security software. If this occurs, disregard the message and continue.

Note: Use TLS 1.2 SSL Certificate.

SSL Private Key (server.key)

This file is the server private key, and it is usually not revealed. The server.key file is paired with the server.crt file to decrypt data encrypted by the SSL certificate.

Note: The passphrase for the private key must be removed before importing to the TeraStation.

Updating SSL Key Files

To update a server certificate and a private key for SSL, follow this procedure.

- 1 From Settings, click *Management*.

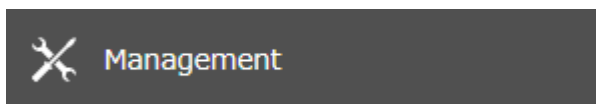

- 2 Click the settings icon () to the right of "Security/Encryption".



- 3** From the *SSL* tab, enter “server.key” for “Secret Key” and “server.crt” for “Server Certificate (.crt)”, then click *Import*.

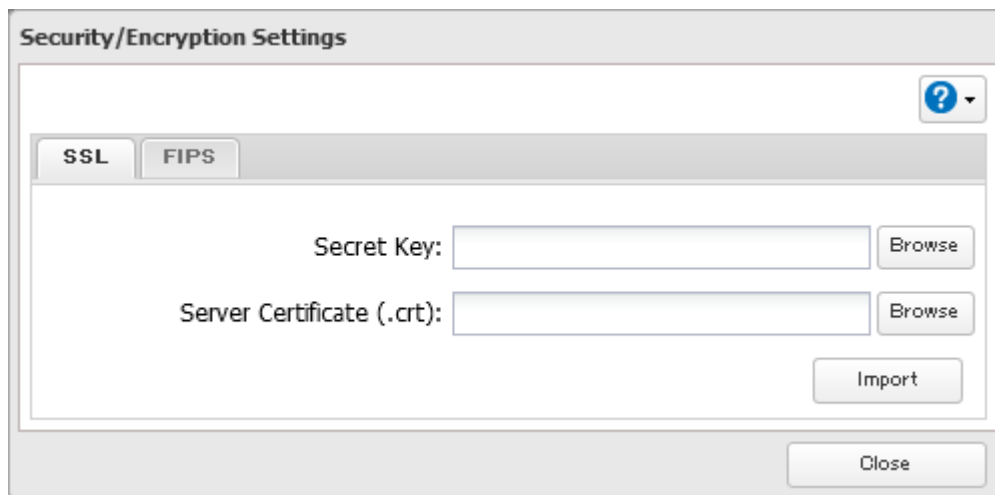

- 4** The process is complete once you close the confirmation window that appears.

Notes:

- Place the SSL key files (server.key, server.crt) directly below the C root drive. The SSL key files may be unable to be updated if they are placed in folders or paths that contain multibyte characters.
- If Settings cannot be displayed after updating, initialize the TeraStation settings.
- Updating the firmware initializes an SSL key.

FIPS Mode

The TeraStation can activate Federal Information Processing Standard (FIPS)-certified encryption that has been validated by Cryptographic Algorithm Validation Program (CAVP). If FIPS mode is enabled, the TeraStation will use FIPS 140-2 compliant cryptographic algorithms for drive encryption and SFTP, and some of the affected features will face the following restrictions:

Affected Function	Details	Corrective Action
Box Storage Sync	All jobs created before FIPS mode is enabled/disabled will be deleted.	Create the jobs again after the mode is changed.
Security/Encryption	Server certificates that use algorithms that don't meet FIPS compliance is unavailable.	Use SHA-2 or higher level server certificates.
Migration	Migration that only transfer data is unavailable.	Disable FIPS mode temporarily before configuring data migration.

Follow the procedure below to enable FIPS mode.

- 1** From Settings, click *Management*.

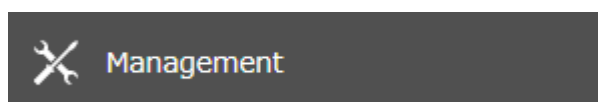

- 2 Click the settings icon () to the right of “Security/Encryption”.



- 3 Click the *FIPS* tab and select “Enable FIPS mode”, then click *Apply*.

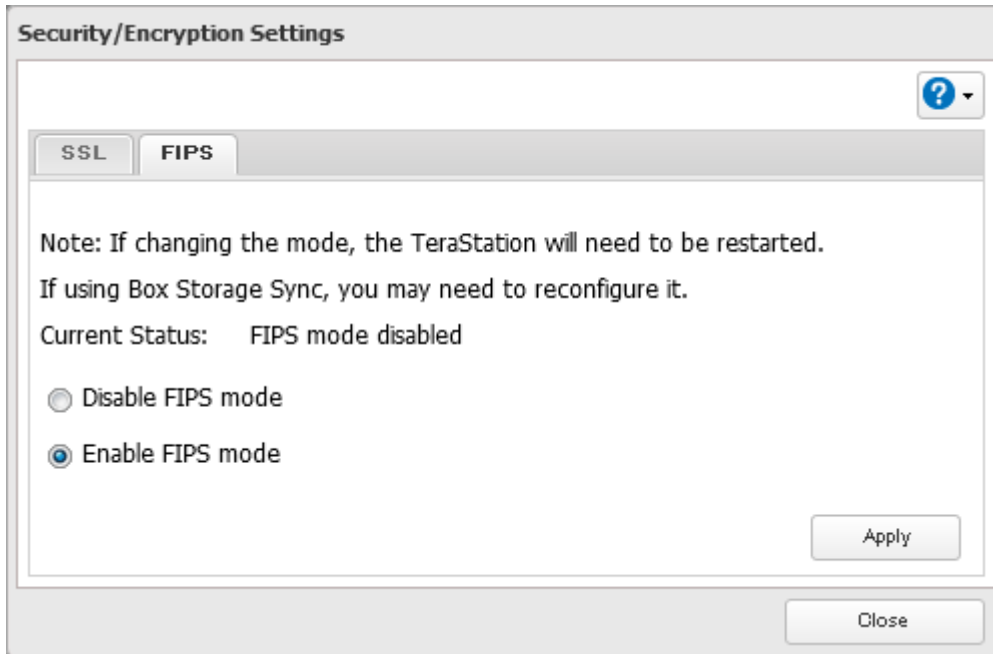

- 4 The “Confirm Operation” screen will open. Enter the confirmation number, then click *OK*.
- 5 The TeraStation will need to be restarted. Click *Yes* to restart the TeraStation. If you select “No”, make sure you restart the TeraStation at a later time to apply FIPS mode settings.

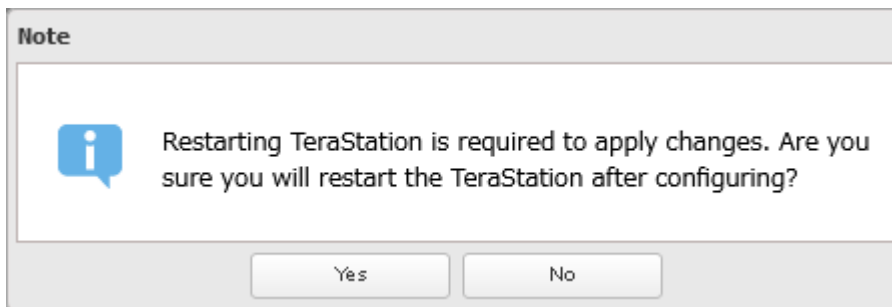

- 6 The process is complete after the TeraStation has been restarted and the power LED turns from blinking to glowing.

Chapter 9 Settings Backup/Restoration

Saving and Applying Settings

The TeraStation's settings can be saved to a USB drive and applied to another Buffalo NAS device of the same series. Use this feature to back up or copy settings to a new Buffalo NAS device.

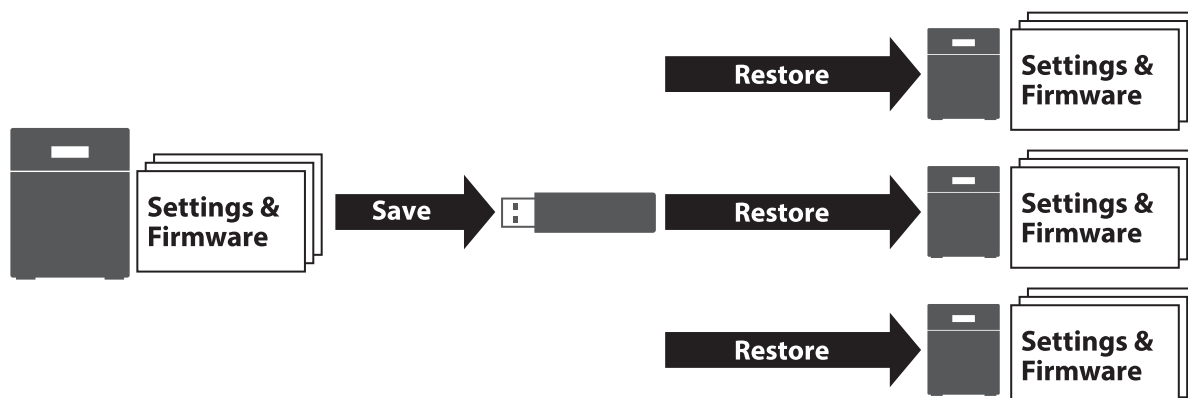

Write down the drive configuration (number of drives, RAID, LVM, etc.) of the Buffalo NAS device whose settings were saved. Make sure that any Buffalo NAS devices that you apply these settings to have the exact same drive configuration before you apply the settings. If the drive configuration is different, you may get unexpected results. The following settings are not saved or applied:

Category	Settings
File Sharing	Subfolders' access restriction settings in the shared folders
	All settings for USB drives
	Two-factor authentication settings in "Users"
	Snapshot settings in "Folder Setup"
Storage	All settings in "Drives"
	All settings in "LVM"
	All settings in "iSCSI"
	USB drive information
Cloud Storage	Job settings of Box Storage Sync
	Job settings of Dropbox Sync
	Job settings of Microsoft OneDrive Sync
Network	All settings except for service port restrictions, Wake-on-LAN, MTU size settings, the "Services Restarted After" option, and FQDN mapping in "IP Address"
	All settings in "Port Trunking"
Backup	All settings except for the <i>Periodic Sync</i> and <i>Advanced Settings</i> tab settings in "Failover"
Management	The TeraStation's hostname
	All settings in "Power Management"
	All settings in "Security/Encryption"
	Display language in Settings
Remote Management Service	All settings

Saving Settings

1 Insert a 1 GB or larger USB drive (not included) into a USB port on the TeraStation.

Note: All data on the USB drive will be erased!

2 From Settings, click *Management*.

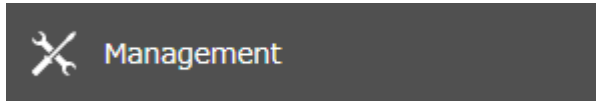

3 Click the settings icon () to the right of "Configuration Management".

 Configuration Management



4 Select "Save current configuration to a USB drive".

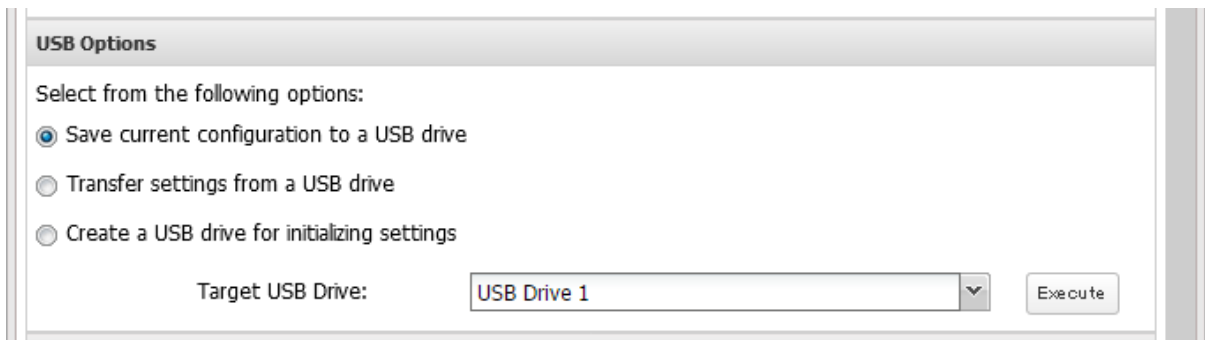

5 From "Target USB Drive", select the USB drive that is connected to the USB port on the TeraStation, then click *Execute*.

6 The "Confirm Operation" screen will open. Enter the confirmation number, then click *OK*.

7 The process is complete once you close the confirmation window that appears.

Troubleshooting:

If the settings are not saved to the USB drive successfully, you may receive an error message such as "The specified operation cannot be executed.". Verify:

- The USB drive has a capacity of 1 GB or more.
- The USB drive is not write-protected.
- Failover is configured on the TeraStation.

Applying Settings

The saved settings can be applied to a different Buffalo NAS device of the same series. If applying settings to another Buffalo NAS device, the unit's current firmware version will be changed to the version used to save the settings.

1 Insert the USB drive with the saved settings into a USB port on the TeraStation.

2 From Settings, click *Management*.

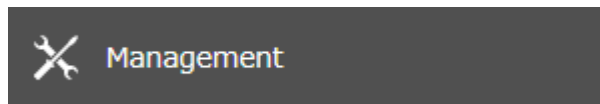

3 Click the settings icon () to the right of "Configuration Management".



4 Select "Transfer settings from a USB drive".



5 From "Target USB Drive", select the USB drive that is connected to the USB port on the TeraStation, then click *Execute*.

6 The "Confirm Operation" screen will open. Enter the confirmation number, then click *OK*.

7 The process is complete once you close the confirmation window that appears.

Transferring Another Buffalo NAS Device's Settings

You can transfer saved settings from another series Buffalo NAS device to your TeraStation. The following settings can be transferred:

- Shared folders which are created from "File Sharing" > "Folder Setup"
- Access restrictions
- Users*
- Groups

*Except two-factor authentication settings

Note: This feature currently supports the following Buffalo NAS devices as of February 2023. The latest compatibility information will be on the [Buffalo website](#).

- TS-X series (TS-XL/R5, TS-WXL/R1, TS-WXL/1D, TS-RXL/R5, TS-XEL/R5 TeraStation models) running firmware version 1.58 or later
- TS5000 series (TS5200D, TS5200DN, TS5400D, TS5400DN, TS5400R, TS5400RN, TS5600D, TS5600DN, TS5800D, TS5800DN TeraStation models)
- TS4000 series (TS4200D, TS4400D, TS4400R, TS4800D TeraStation models)
- TS3000 series (TS3200D, TS3400D, TS3400R TeraStation models)
- TS5010 series (TS5210DN, TS5410DN, TS5410RN, TS5810DN, TS51210RH TeraStation models)
- TS3010 series (TS3210DN, TS3410DN, TS3410RN TeraStation models)
- TS6000 series (TS6200DN, TS6400DN, TS6400RN TeraStation models)

- TS3020 series (TS3220DN, TS3420DN, TS3420RN TeraStation models)
- TS5020 series (TS5420DN, TS5420RN, TS5820DN, TS51220RH TeraStation models)
- TS71210RH TeraStation model

Creating a Config File (.nas config)

Procedure for TS-X Series Models

To transfer settings from TS-X series TeraStations, it will use the “NS-SHFT” software to create a config file. NS-SHFT can be downloaded from the [Buffalo website](#).

For the procedure on creating the config file, refer to the NS-SHFT user guide.

Procedure for Buffalo NAS Devices Other Than TS-X Series Models

Follow the procedure below to create a config file on a Buffalo NAS device that is not part of TS-X series TeraStations.

- 1 Refer to the user manual of the Buffalo NAS device whose settings will be saved to a USB drive.
- 2 Access the “usbdisk x” shared folder while connecting the USB drive to the Buffalo NAS device whose settings were saved in the previous step. The “x” in the folder name represents the USB port number you connected the drive to.
- 3 Copy and paste the .nas_config file to the desired location on your computer.
- 4 The process is complete once the .nas_config file is saved to the desired location.

Transferring Settings

Follow the procedure below to transfer settings from another series Buffalo NAS device.

- 1 Before transferring access restrictions with Active Directory domain users, make sure the migration target Buffalo NAS devices are joined to the same domain controller. To have the unit join the domain network, refer to the procedure in the “[Restricting AD Domain User Access to Shared Folders](#)” section in chapter 4. If you didn’t configure access restrictions with Active Directory domain users, skip to the next step.
- 2 From Settings, click *Management*.

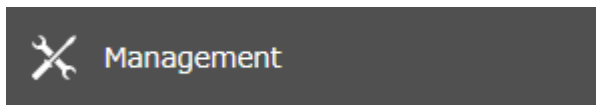

- 3 Click the settings icon () to the right of “Configuration Management”.



- 4** Click *Browse* and choose the config file (.nas_config) that was created with the migration source Buffalo NAS device. If the config file was created with a password, enter it into the “Password” field.

- 5** Click *Import*.
- 6** The “Confirm Operation” screen will open. Enter the confirmation number, then click *OK*.
- 7** The process is complete once you close the confirmation window that appears.

Notes:

- If the migration target Buffalo NAS device contains shared folders, users, and groups that share the same name as the transferred settings, the existing settings will be overwritten. If the users and groups meet the following conditions, the settings will not be transferred: users share the same name with groups that already exist on the migration target Buffalo NAS device; groups share the same name with users on the migration target Buffalo NAS device.
- If the migration target Buffalo NAS devices have already added some shared folders, users, and groups, the transferred settings may exceed the maximum number of allowed shared folders, users, or groups. Excess items will not be transferred. After migration finishes, open Settings and verify that all settings were properly transferred.

Restoring Factory Defaults

The settings on the TeraStation can be restored to factory defaults using Settings or an USB drive.

Initializing from Settings

To initialize the TeraStation to its factory defaults from Settings, follow the procedure below.

- 1** From Settings, click *Management*.

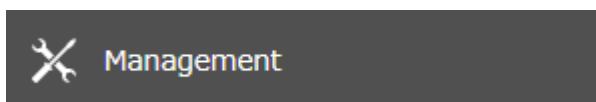

- 2** Click the settings icon () to the right of “Restore/Eraser”.

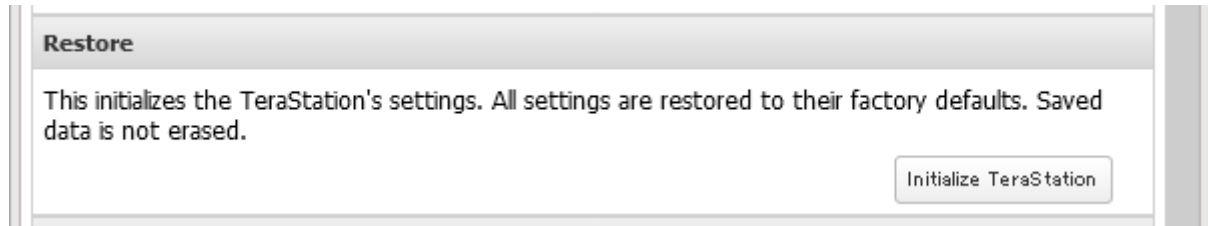

3 Click *Initialize TeraStation*.

4 The “Confirm Operation” screen will open. Enter the confirmation number, then click *OK*.

5 The settings will be restored to its factory default settings. The **I26** message will appear as a notification while settings are being restored.

6 The process is complete when the **I26** message disappears.

Initializing Using the USB Initialization Drive

A USB initialization drive will restore the settings on your TeraStation to their factory defaults. You can initialize them without logging in to Settings. Follow the procedure below to create a USB initialization drive.

Notes:

- You can use the USB initialization drive to initialize settings on the same TeraStation unit that created it.
- Normally, making and using a USB initialization drive will not affect data on the TeraStation. However, always back up your data regularly!
- This USB initialization drive can be used to recover the system if your TeraStation doesn't boot at all. In this case, if the data partition is damaged, then all your data will be deleted by the recovery process.

Creating a USB Initialization Drive

1 Insert a 1 GB or larger USB drive (not included) into a USB port on the TeraStation.

Note: All data on the USB drive will be erased!

2 From Settings, click *Management*.

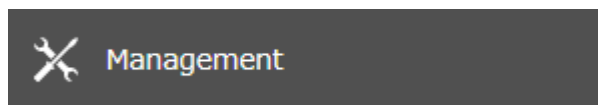

3 Click the settings icon () to the right of “Configuration Management”.



4 Select “Create a USB drive for initializing settings”.

5 From “Target USB Drive”, select the USB drive that is connected to the USB port on the TeraStation, then click *Execute*.

6 The “Confirm Operation” screen will open. Enter the confirmation number, then click *OK*.

7 The process is complete once you close the confirmation window that appears. Refresh the browser and log in to Settings again.

Starting Initialization

To initialize the settings on your TeraStation with the USB drive created above, follow the procedure below.

Note: If using the USB initialization drive to initialize, the unit’s current firmware version will be changed to the version used to create the USB initialization drive.

- 1** Turn off the TeraStation by pressing and holding down the power button for three seconds.
- 2** Insert the USB drive into a USB port on the TeraStation. Make sure that no other USB drives are currently connected to any USB ports on the TeraStation.
- 3** Power on the TeraStation while holding down the function button.
- 4** When the I41 message appears as a notification, press the function button.
- 5** The I37 message will appear as a notification while the initialization process is running. It will take several minutes to initialize the settings. The TeraStation will restart when it’s finished.
- 6** The process is complete when the I37 message disappears.

Dismount the USB drive before unplugging it. Refer to the [“Dismounting Drives”](#) section in chapter 5 for the procedure on dismounting drives.

Resetting the Administrator Password

If you forget the admin username or password and cannot log in to Settings, or incorrect network settings are configured and Settings becomes inaccessible, initialize these settings by following the procedure below.

- 1** Press and hold down the reset button (refer to the [“Diagrams”](#) section in chapter 2) for 10 seconds.
- 2** The TeraStation will beep and the I23 message will appear as a notification during initialization.

3 The process is complete when the **I23** message disappears.

This will typically reset the admin username and password, "powerusers" group privileges*, two-factor authentication settings, IP settings other than Wake-on-LAN, port trunking, SSL, and service port restriction settings to their factory default values.

This button can be disabled in Settings; to do so, navigate to *Management > Restore/Erase > Edit* under "Reset Button", then select "Keep current admin username and password" and click *OK*.

*If you have manually created the "powerusers" group on a TeraStation running firmware version 1.34 or earlier, and then transfer or migrate the settings to a TeraStation running firmware version 1.36 or later, the system default "powerusers" group privileges will be overwritten by the manually-created "powerusers" group privileges. In such a case, use the reset button to revert to the system default values.

Chapter 10 Network Settings

Wake-on-LAN

The TeraStation supports Wake-on-LAN, which allows it to be turned on remotely. The TeraStation will be turned on automatically in the following situations: receiving a Wake-on-LAN packet, recovering from a power outage, disconnecting and reconnecting the power cable.

- 1 From Settings, click *Network*.



- 2 Click the settings icon () to the right of "IP Address".



- 3 Click *Edit* and enable "Wake-on-LAN", then click *OK*.

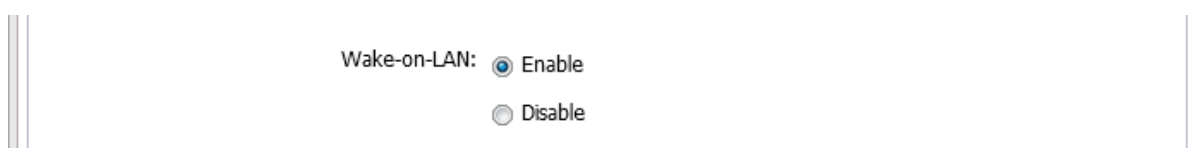

- 4 The process is complete once you close the confirmation window that appears.

Wake-on-LAN is now enabled. As long as the TeraStation is connected to a power source and the network, you can turn it on remotely.

Notes:

- After receiving the Wake-on-LAN packet, the TeraStation may take up to five minutes to be ready to use.
- To use Wake-on-LAN, you'll need Wake-on-LAN software that sends Wake-on-LAN packets. The TeraStation does not include Wake-on-LAN software.
- The TeraStation does not support using Wake-on-LAN and port trunking at the same time. You may use either feature, but not both at the same time.

Port Trunking

Two Ethernet cables can be used to establish two separate communication routes, providing LAN port redundancy and improving communication reliability. The use of two Ethernet cables enables access to the TeraStation even if one of the cables becomes disconnected.

The port trunking modes that can be set on the TeraStation are shown below:

Trunking Mode	Characteristics
Active-backup	Only one NIC slave in the bond is active. A different slave becomes active if and only if the active slave fails.

Trunking Mode	Characteristics
Dynamic link aggregation	Creates aggregation groups that share the network speed and duplex settings. Utilizes all slave network interfaces in the active aggregator group according to the 802.3ad specification. Note: To use this mode, a separate intelligent switch that supports IEEE 802.3ad is required. Configure LACP on the switch first.
TLB	The outgoing network packet traffic is distributed according to the current load (relative to the speed) on each network interface slave.
ALB	The incoming and outgoing network packet traffic is distributed according to the current load on each network interface slave. The receive load balancing is achieved by ARP negotiation.

Note: If the TeraStation is being used as an iSCSI drive, disable iSCSI before changing network settings such as port trunking. Navigate to *Storage > iSCSI* in Settings and move the iSCSI switch to the **off** position temporarily.

1 Connect the hub's LAN port and TeraStation's LAN port using two Ethernet cables. If you are using an intelligent switch, connect the LAN port that was previously configured for port trunking.

2 From Settings, click *Network*.



3 Click the settings icon (⚙️) to the right of "Port Trunking".



4 Select the LAN port that will be used from the drop-down list.

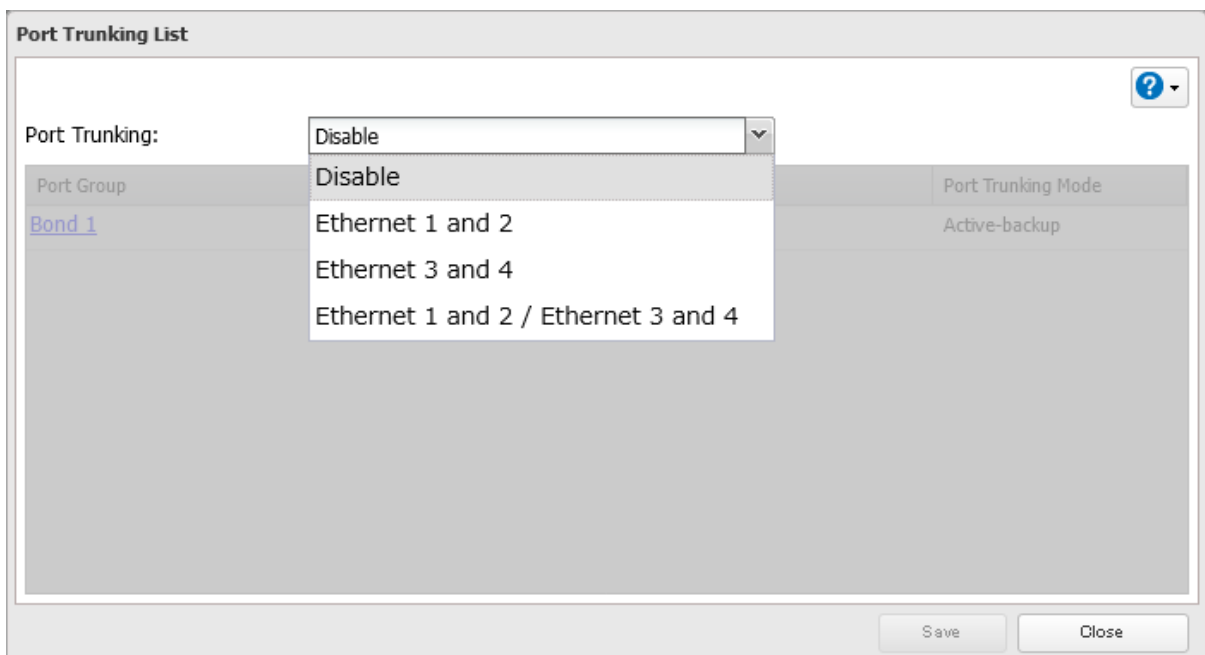

5 Click a port trunking bond.

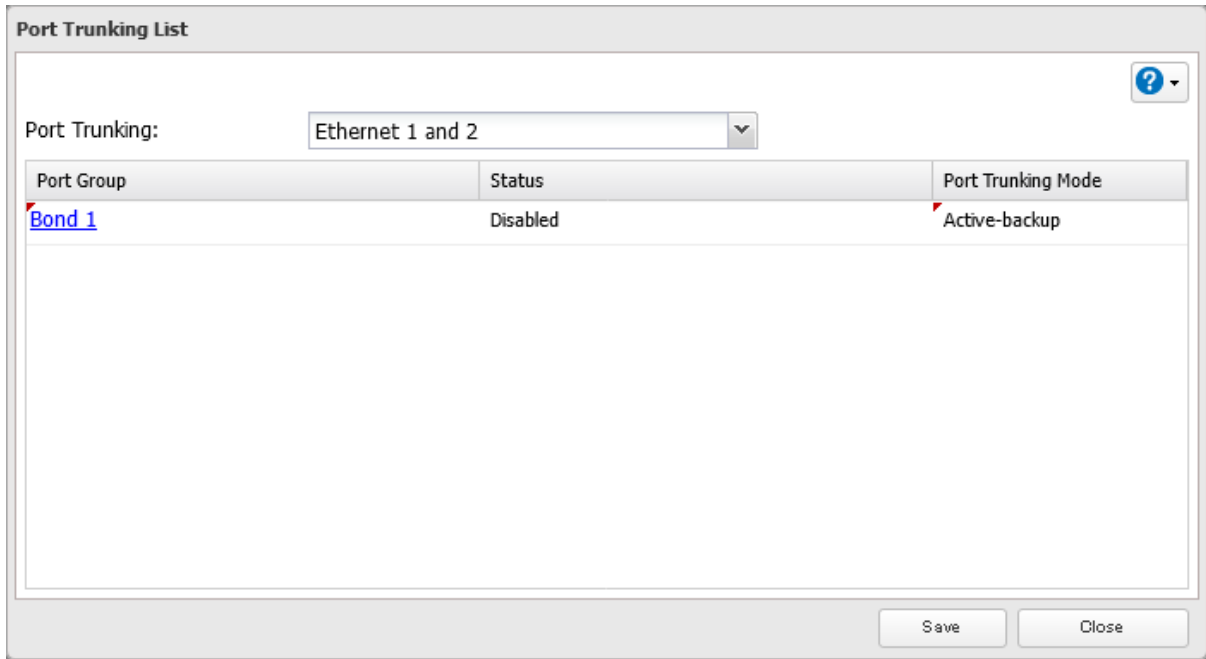

6 Select the port trunking mode and click *OK*.

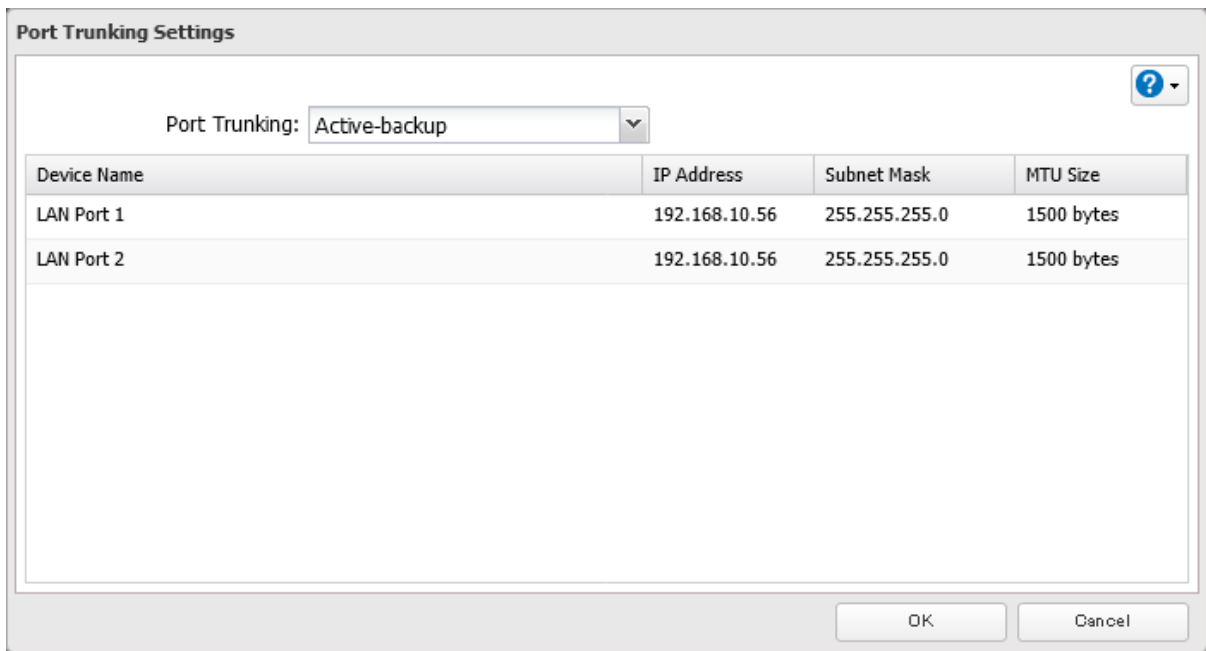

7 Click *Save*.

Port Group	Status	Port Trunking Mode
Bond 1	Disabled	Active-backup

8 Read the message carefully and click *Yes*.

Note

Are you sure you want to change your current port trunking configuration?

Yes No

9 Click *Yes* to restart the TeraStation. If you select “No”, make sure you restart the TeraStation at a later time to apply port trunking settings.

Note

Restarting TeraStation is required to apply changes. Are you sure you will restart the TeraStation after configuring?

Yes No

10 The process is complete after the TeraStation has been restarted.

SNMP

If SNMP is enabled, you can browse your TeraStation from SNMP-compatible network management software. Examples of frequently-notified traps are described in the [“Relevant Trap List”](#) subsection below.

1 From Settings, click *Network*.



2 Move the SNMP switch () to the  position to enable SNMP.



3 Click the settings icon () to the right of "SNMP".



4 Click *Edit* and select whether to use SNMP version 2 or version 3.

 A dialog box titled "SNMP Settings" with a close button (red X) in the top right corner. It contains two radio button options: "Use SNMPv2" (selected) and "Use SNMPv3" (disabled). Under "Use SNMPv2", there is a text field for "SNMP Community Name *" containing "TeraStation", and "Trap Notify:" options for "Enable" (selected) and "Disable". A "Trap Settings" section contains text fields for "Trap Notify Community Name *" and "Trap Notify IP Address *". Under "Use SNMPv3", there is a text field for "Username *" containing "snmp", and a section for "Authentication and Privacy Protocol: SHA / AES" with text fields for "Authentication and Privacy Password *" and "Password (Confirm) *". "OK" and "Cancel" buttons are at the bottom.

5 Configure the desired settings, then click *OK*.

6 The process is complete once you close the confirmation window that appears.

SNMP is now enabled. For further use, configure your SNMP-compatible network management software using the Buffalo-specific MIB (management information base) file. The MIB file is available from the [Buffalo website](#). Depending on which SNMP client software you use, the procedure for configuring the software will differ. For more detailed information on configuring the client software, refer to its help or included manual.

Note: The SNMP community name may contain up to 255 alphanumeric characters, hyphens (-), underscores (_), spaces, commas (,), periods (.), colons (:), semicolons (;), tildes (~), and the symbols @ ! # \$ % & * + = ?) (' / \.

Relevant Trap List

Standard Public MIB Traps

Conditions	Trap Name	OID
SNMP service starts.	coldStart	1.3.6.1.6.3.1.1.5.1
SNMP service ends.	nsNotifyShutdown	1.3.6.1.4.1.8072.4.0.2

Private MIB Traps

If any traps are not listed in the following chart, refer to the web page for downloading the private MIB file on the [Buffalo website](#) for more detailed information.

Conditions	Trap Name
Backup fails.	nasBackupStatus
The RAID array is in degraded mode.	nasDiskStatus
An error occurs and an error code is displayed.	nasErrorOccur
An event occurs and an event code is displayed.	nasInformationOccur

Proxy Server

If you place the TeraStation on a network that passes through a proxy server, configuring the proxy server settings is recommended. Unless you configure the proxy settings, firmware updates in Settings will not work. To configure the settings, follow the procedure below.

- 1 From Settings, click *Network*.



- 2 Click the settings icon (⚙️) to the right of "Proxy Server".

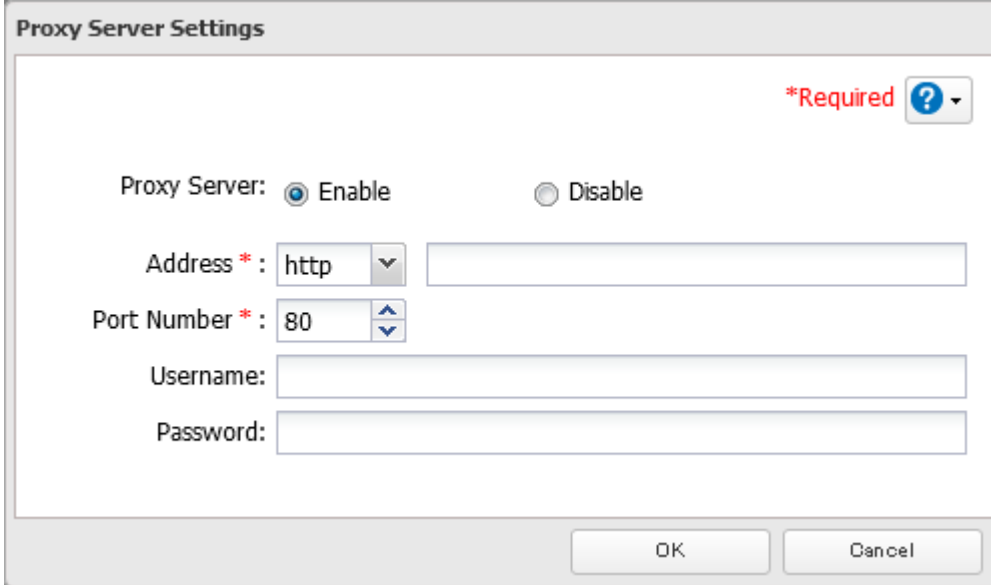

3 Enable “Proxy Server”.

The image shows a dialog box titled "Proxy Server Settings". In the top right corner, there is a red asterisk followed by the word "*Required" and a blue question mark icon. The main content area contains the following fields:

- Proxy Server:** Two radio buttons are present: "Enable" (which is selected) and "Disable".
- Address *:** A dropdown menu is set to "http", followed by an empty text input field.
- Port Number *:** A spin box is set to "80".
- Username:** An empty text input field.
- Password:** An empty text input field.

At the bottom of the dialog box, there are two buttons: "OK" and "Cancel".

4 Enter the proxy server IP address or hostname, port number, username and password, then click *OK*.

5 The process is complete once you close the confirmation window that appears.

Once you configure the proxy server settings, you may use the settings for features that will link with cloud storage services by selecting the “Configured settings” option on each settings page.

Jumbo Frames

If your other network devices support jumbo frames, you may be able to improve network performance.

Notes:

- If the TeraStation is being used as an iSCSI drive, to change the settings, navigate to *Storage > iSCSI* in Settings and move the iSCSI switch to the **off** position temporarily before changing settings.
- Make sure the TeraStation’s MTU size is smaller than the hub or router’s. Larger MTU sizes may cause data to not transfer properly to the TeraStation.

1 From Settings, click *Network*.



















2 Click the settings icon () to the right of “IP Address”.



3 Click *Edit* and select or enter the desired MTU size, then click *OK*.

Interface	DHCP	IP Address	Subnet Mask	MTU Size
LAN Port 1	<input checked="" type="checkbox"/>	19.16.200.47	255.255.255.0	4084
LAN Port 2	<input checked="" type="checkbox"/>		255.255.255.0	1500
LAN Port 3	<input checked="" type="checkbox"/>		255.255.255.0	1500
LAN Port 4	<input checked="" type="checkbox"/>		255.255.255.0	1500

4 The process is complete once you close the confirmation window that appears.

Connection			Transmission	
				Transfer data using jumbo frames.
				Transfer data without using jumbo frames.
				Transfer data without using jumbo frames.
				No data can be transferred.

Changing the IP Address

Normally, the TeraStation's IP address is set automatically by a DHCP server on your network. If you prefer, you can set it manually. An easy way to do this is to change it on NAS Navigator2. The procedure to change the IP address in Settings is below.

Note: If the TeraStation is being used as an iSCSI drive, to change the settings, navigate to *Storage > iSCSI* in Settings and move the iSCSI switch to the **off** position temporarily before changing settings.

1 From Settings, click *Network*.



2 Click the settings icon () to the right of "IP Address".



3 Click *Edit* and clear the "DHCP" checkbox, then enter the desired IP address and its subnet mask.

 A dialog box titled "IP Address Settings" with a question mark icon in the top right corner. It contains a table with the following data:

Interface	DHCP	IP Address	Subnet Mask	MTU Size
LAN Port 1	<input type="checkbox"/>	19.16.200.47	255.255.255.0	1500
LAN Port 2	<input checked="" type="checkbox"/>		255.255.255.0	1500
LAN Port 3	<input checked="" type="checkbox"/>		255.255.255.0	1500
LAN Port 4	<input checked="" type="checkbox"/>		255.255.255.0	1500

4 Select "User (static)" from the drop-down list for both the "Gateway Owner" and "DNS Owner" options, then enter the desired default gateway address and DNS server addresses.

 A configuration window with the following fields:

- Gateway Owner: User (static) [dropdown]
- Default Gateway Address: 192.168.10.1 [text input]
- DNS Owner: User (static) [dropdown]
- Primary DNS Server: 192.168.10.1 [text input]
- Secondary DNS Server: [text input]
- Services Restarted After: 1 [dropdown] seconds

 At the bottom right, there are "OK" and "Cancel" buttons.

5 Click *OK*. The process is complete once you close the confirmation window that appears.

Notes:

- Only one default gateway and DNS address can be configured for all LAN ports. Different network addresses cannot be assigned to the LAN ports.
- Do not set the IP address of the same segment for all LAN ports. This may cause unstable network communication.
- Network services such as SMB or FTP will restart when the Ethernet cable is disconnected/reconnected or if a network issue occurs. You can specify the time to delay the restart at the "Services Restarted After" option.

- When you disable DHCP, all addresses including default gateway and DHCP server addresses cannot be assigned automatically, even if you can select the “Assign automatically” options for them.

Mapping IP Address and Hostname

The TeraStation allows you to map an IP address and a hostname (FQDN) of another host you would like the TeraStation to communicate with, such as the domain controller. If you configure the mapping pair, the TeraStation can be accessed using the configured pair when name resolution is needed. Follow the procedure below to configure FQDN mapping.

- 1 From Settings, click *Network*.



- 2 Click the settings icon () to the right of “IP Address”.



- 3 Click *FQDN Mapping*.

IP Address List

Interface	Type	DHCP	IP Address	Subnet Mask	MTU Size	More Detai
LAN Port 1	10GbE	✓	19.16.200.33	255.255.255.0	1500 bytes	▶
LAN Port 2	10GbE	✓	—	—	1500 bytes	▶
LAN Port 3	10GbE	✓	—	—	1500 bytes	▶
LAN Port 4	10GbE	✓	—	—	1500 bytes	▶

Wake-on-LAN: Disabled

Gateway Owner: Automatically assigned (LAN Port 1)

Default Gateway Address: 19.16.200.254

DNS Owner: Automatically assigned

Primary DNS Server: 19.16.200.254

Secondary DNS Server: Not assigned

Services Restarted After: 1 seconds

Port Protocols
Port Trunking
FQDN Mapping
Edit
Close

4 Click *Add*.

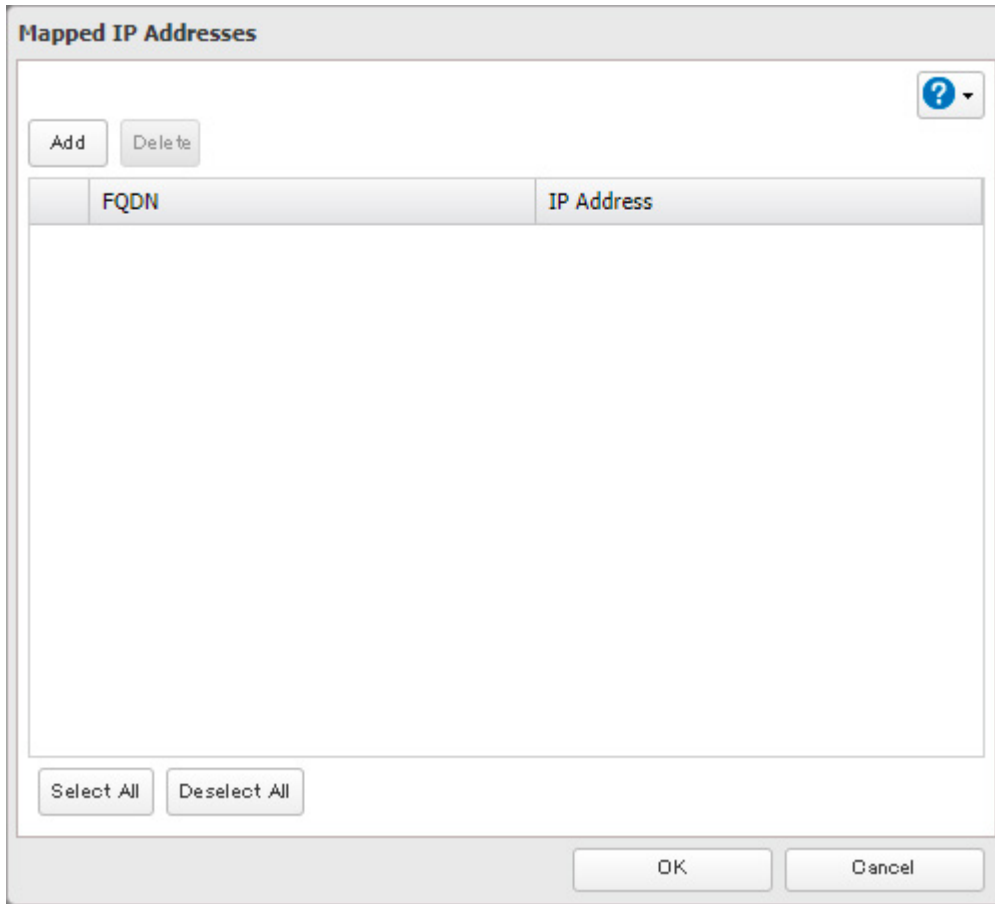

5 Enter the hostname (FQDN) and the IP address that you want to map, then click *OK*.

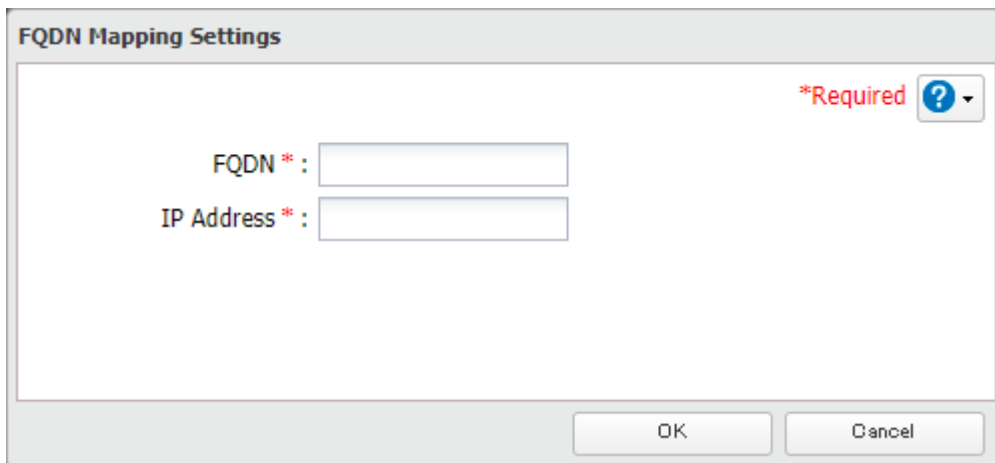

6 Click *OK* again. The process is complete once you close the confirmation window that appears.

Chapter 11 Advanced Features

Email Notification

Your TeraStation can send you email reports daily, or whenever settings are changed or an error occurs. You can configure the events that will trigger notifications from any of the following functions: quotas, drives (internal, external, or RAID array), fan, power supply unit, backup, replication, failover, system alert.



Refer to the contextual help in Settings for more detailed information such as when the notification email will be sent or the differences between the notification categories.

Enabling Email Notification

Follow the procedure below to enable email notification functionality.

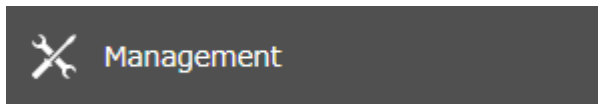
- 1 From Settings, click *Management*.



- 2 Move the email notification switch () to the  position to enable email notification.



- 3 Click the settings icon () to the right of "Email Notification".



- 4** Click *Edit* and enter your email server settings and the notification email's default subject, then configure recipients and the time when email reports will be sent.

If you select an authentication type other than "Disable" from the drop-down list, you can enter the sender email address and credentials of the email server. If the password includes an apostrophe ('), that email server account cannot be used.

Email Notification Settings *Required ?

SMTP Server Address * :

SMTP Port * :

Authentication Type:

Sender Address:

POP3 Server Address:

POP3 Port:

SSL/TLS:

Username:

Password:

Subject * :

Add Delete Select from List

Recipients * :

Name	Recipients	Class

Select All Deselect All

Send Daily Report at:

OK Cancel

- 5** Click *OK*. The process is complete when you select either *Yes* or *No* to have a test email sent.

Changing Events for Email Reports

- 1** From Settings, click *Management*.

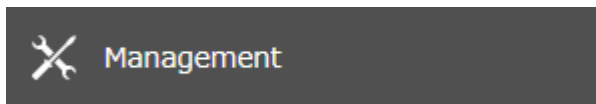

- 2** Click the settings icon () to the right of "Email Notification".



- 3** Click *Advanced Reports*.

4 On the displayed screen, select or clear any checkboxes for each category, then click *OK*.

Report Settings		<input checked="" type="checkbox"/> Daily Report	<input checked="" type="checkbox"/> Info	<input checked="" type="checkbox"/> Alert	<input checked="" type="checkbox"/> Error
Categories		<input checked="" type="checkbox"/>	<input checked="" type="checkbox"/>	<input checked="" type="checkbox"/>	<input checked="" type="checkbox"/>
Drive Quota	Shared Folder	<input checked="" type="checkbox"/>	<input checked="" type="checkbox"/>	<input checked="" type="checkbox"/>	<input checked="" type="checkbox"/>
Storage	Internal Drive	<input checked="" type="checkbox"/>	<input checked="" type="checkbox"/>	<input checked="" type="checkbox"/>	<input checked="" type="checkbox"/>
	RAID Array	<input checked="" type="checkbox"/>	<input checked="" type="checkbox"/>	<input checked="" type="checkbox"/>	<input checked="" type="checkbox"/>
	USB Drive	<input checked="" type="checkbox"/>			
Fan				<input checked="" type="checkbox"/>	
Power Supply Unit					<input checked="" type="checkbox"/>
Backup			<input checked="" type="checkbox"/>	<input checked="" type="checkbox"/>	
Replication				<input checked="" type="checkbox"/>	
Failover			<input checked="" type="checkbox"/>	<input checked="" type="checkbox"/>	
System Alert			<input checked="" type="checkbox"/>		

Notification emails will be categorized into the following importance levels. Refer to the chart below for the detailed information of category importance levels.

Levels	Details
Daily Report	Describes the status of the TeraStation in a daily report email.
Info	Sends a notification email if an event occurs. Info reports will contain just information such as capacity information, job starts/completes, etc.
Alert	Sends a notification email if a non-critical error occurs. Refer to the “Alerts” section in chapter 14 for the list of events that will trigger this event notification. Alert reports will contain warnings such as something has failed, but the function or unit can continue operating as usual. It is recommended to perform the corrective action for the alert as soon as possible.
Error	Sends a notification email if a critical error occurs. Refer to the “Errors” section in chapter 14 for the list of events that will trigger this event notification. Error reports will describe critical failures that prevented a function or unit from operating properly. It is recommended to perform the corrective action for the error immediately.

5 Click *OK*. The process is complete once you close the confirmation window that appears.

Sleep Mode

To save energy, you can specify times to put the TeraStation into sleep (standby) mode, during which the drives and LEDs are turned off.

1 From Settings, click *Management*.

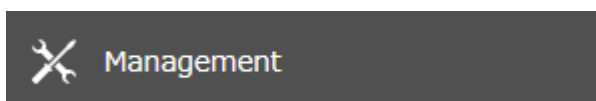

2 Click the settings icon () to the right of “Sleep Timer”.



Sleep Timer



3 Click *Edit* and specify the timer interval, wake-up time, and time to enter sleep mode, then click *OK*.

Sleep Timer Settings

Timer 1

Schedule: Weekly (select days of the week)

Sunday Monday Tuesday Wednesday Thursday Friday Saturday

Wake Up at: 07 : 00

Begin Sleep at: 22 : 00

Timer 2

Schedule: Disable

Sunday Monday Tuesday Wednesday Thursday Friday Saturday

Wake Up at: 00 : 00

Begin Sleep at: 00 : 00

Timer 3

Schedule: Disable

Sunday Monday Tuesday Wednesday Thursday Friday Saturday

Wake Up at: 00 : 00

Begin Sleep at: 00 : 00

OK Cancel

4 The process is complete once you close the confirmation window that appears.

Notes:

- Up to three timers can be set.
- The time to enter sleep mode can be set from 12:00 a.m. to 3:45 a.m. of the next day. The time to wake from sleep mode can be set from 12:00 a.m. to 11:45 p.m. If the time to enter sleep mode is after 12:00 a.m., the wake-up time setting may be from 4:00 a.m. to 11:45 p.m.
- The time to enter sleep mode should not be set to the same time as or earlier than the start time.
- If sleep mode timer is scheduled to go off while logging in to Settings, checking or formatting a drive, running a backup process, or setting a backup job within five minutes of the current time, the TeraStation will not enter sleep mode when the configured time is reached.
- Examples of timer settings are shown below:

- **Example 1:**

Sleep Timer Settings

Timer 1: Daily 12:00 (wake up)–24:00 (begin sleep)

Timer 2: Not used

Timer 3: Not used

Actual Behavior

Normal operation begins at 12:00 p.m. and the unit enters sleep mode at 12:00 a.m.

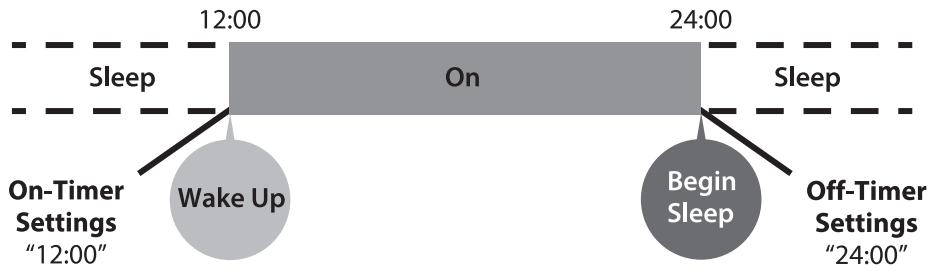

○ **Example 2:**

Sleep Timer Settings

Timer 1: Daily 9:00 (wake up)–18:00 (begin sleep)

Timer 2: Wednesday 10:00 (wake up)–20:00 (begin sleep)

Timer 3: Not used

Actual Behavior

On days other than Wednesday, normal operation begins at 9:00 a.m. and the unit enters sleep mode at 6:00 p.m.

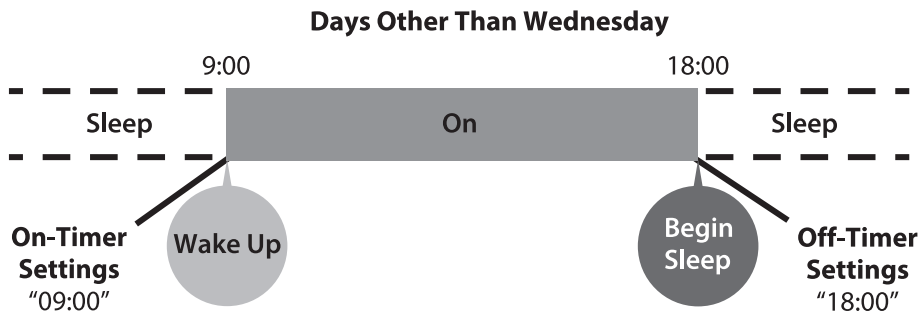

On Wednesday, normal operation begins at 9:00 a.m. and the unit enters sleep mode at 8:00 p.m., as when scheduled times on the timer overlap on Wednesday, normal operation begins at the earliest time, and the unit enters sleep mode at the latest time.

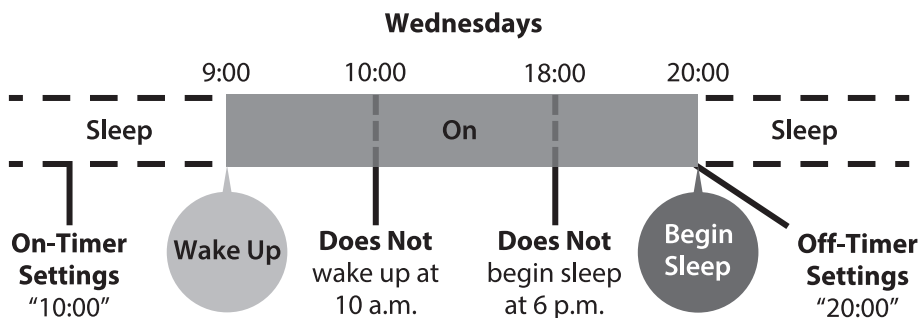

○ **Example 3:**

Sleep Timer Settings

Timer 1: Daily 9:00 (wake up)–18:00 (begin sleep)

Timer 2: Wednesday 10:00 (wake up)–1:00 a.m. of the next day (begin sleep)

Timer 3: Not used

Actual Behavior

On days other than Wednesday, normal operation begins at 9:00 a.m. and the unit enters sleep mode at 6:00 p.m.

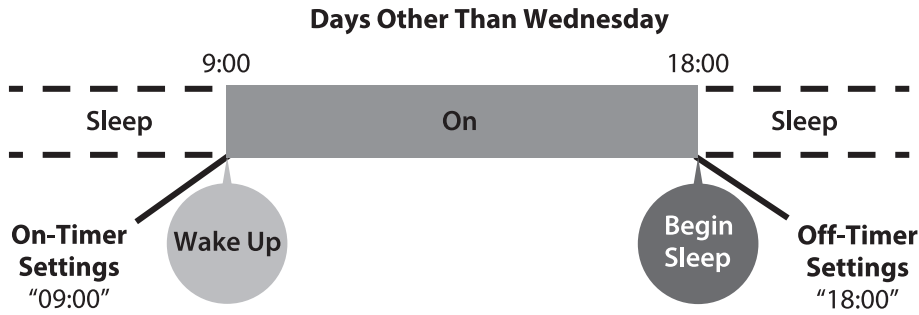

On Wednesday, normal operation begins at 9:00 a.m. and the unit enters sleep mode at 1:00 a.m. of the next day, as when scheduled times on the timer overlap on Wednesday, normal operation begins at the earliest time, and the unit enters sleep mode at the latest time.

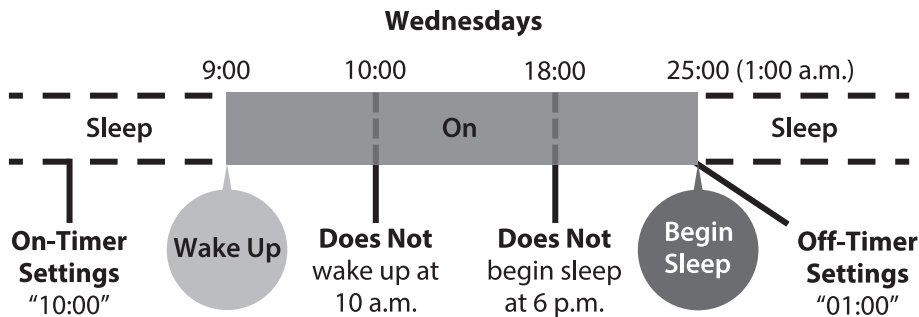

o **Example 4:**

Sleep Timer Settings

Timer 1: Daily 9:00 (wake up)–18:00 (begin sleep)

Timer 2: Wednesday 7:30 (wake up)–22:00 (begin sleep)

Timer 3: Not used

Actual Behavior

On days other than Wednesday, normal operation begins at 9:00 a.m. and the unit enters sleep mode at 6:00 p.m.

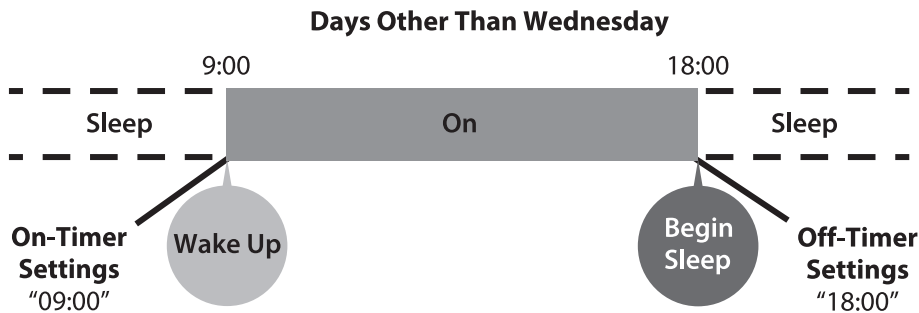

On Wednesday, normal operation begins at 7:30 a.m. and the unit enters sleep mode at 10:00 p.m., as when scheduled times on the timer overlap on Wednesday, normal operation begins at the earliest time, and the unit enters sleep mode at the latest time.

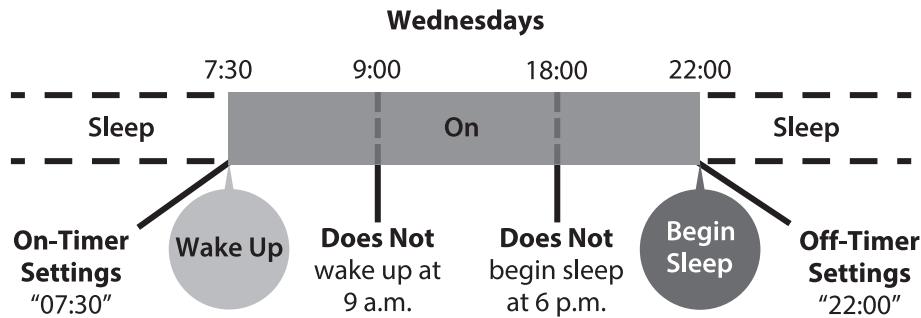

- To wake the TeraStation from sleep mode before the wake-up time, press and hold down the power button for three seconds.

UPS (Uninterruptible Power Supply)

If a UPS device (sold separately) is attached, the TeraStation can be automatically shut down to protect data in the event of a power outage.

This TeraStation model supports multiple power supply unit connections, and the procedure to configure UPS devices will differ depending on how many power supply units are installed on your NAS device. Depending on your setup, select the appropriate UPS configuration procedure below for your TeraStation.

Notes:

- If the TeraStation is connected directly to a UPS device, select "Sync with UPS connected to this TeraStation". If a different Buffalo NAS device is connected to the UPS device, select "Sync with UPS connected to another Buffalo NAS device on the same network". After making this selection, enter the IP address of the Buffalo NAS device that will be the sync source into "Other Buffalo NAS's IP Address".
- If you don't want to connect any UPS devices, select "Do not synchronize with UPS" and the operation for if a power supply failure occurred. If "Use last state" at "AC Power Recovery" is selected, the TeraStation will revert to the state before the power supply failure occurred. If "Stay off" is selected, the TeraStation will remain off even after the TeraStation shuts down due to the power supply failure.
- When the TeraStation restarts after an automatic shutdown such as from a power outage or power supply issue, verify that external power has been restored. If the TeraStation is turned on while it is still running on the UPS device and external power has not been restored, the automatic shutdown will not be performed, even after the specified time elapses.
- To have the TeraStation power on automatically after external power has been restored and the NAS is no longer drawing power from the UPS device, set the "Wake Up TeraStation After Power Supply Recovers" option to "Yes".

One Power Supply Unit Is Installed

- Power off the TeraStation.
- Plug the power cable of the UPS device into a wall socket.
- Connect the power cable of the TeraStation to the UPS device.
- Connect the UPS device and the TeraStation.
- Turn on the UPS device, then the TeraStation.

6 From Settings, click *Management*.

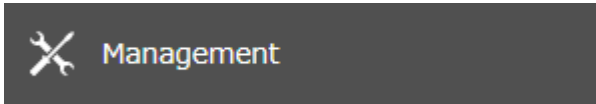

7 Click the settings icon (⚙️) to the right of "Power Management".

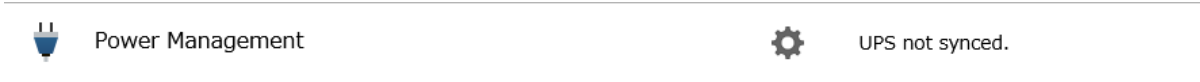

8 Click *Edit* and configure the desired settings, then click *OK*.

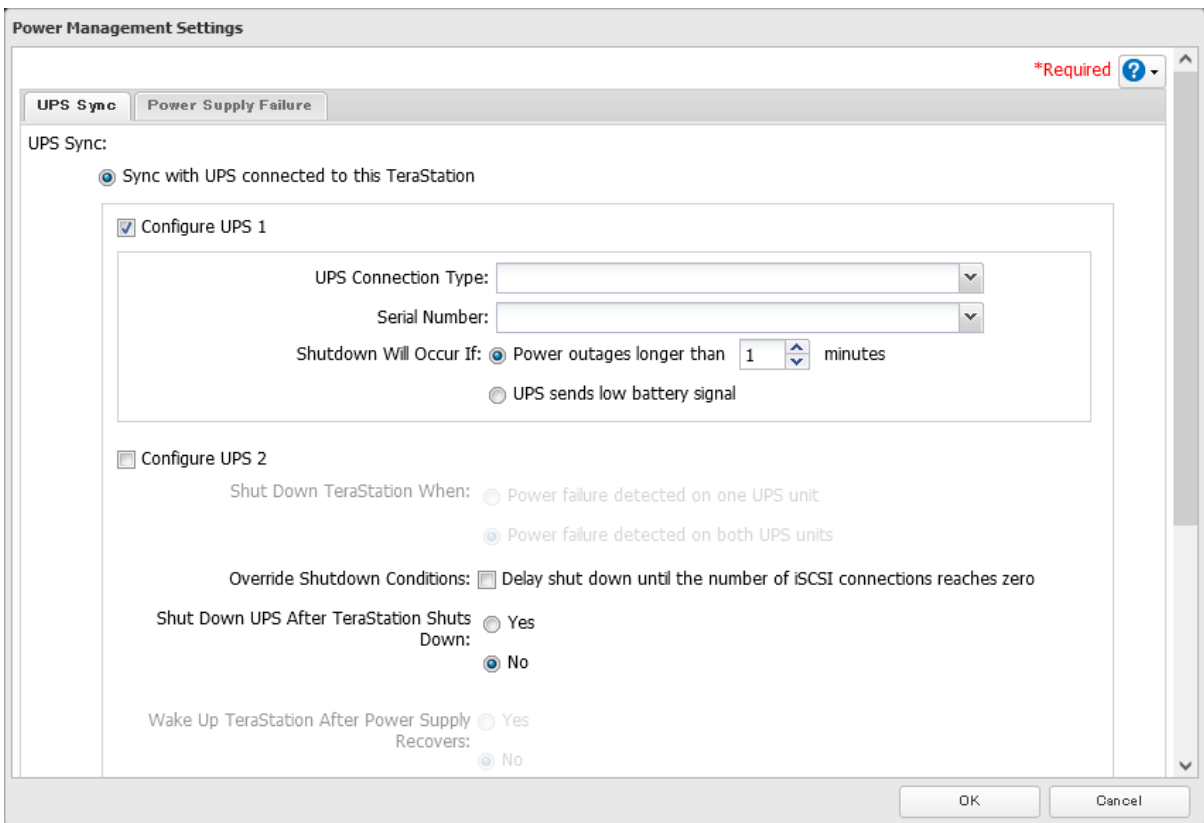

9 The process is complete once you close the confirmation window that appears.

Two Power Supply Units Are Installed

Refer to the setups below for the best connection configuration for you.

A. To Boot the TeraStation After the Power Supply Recovers (Recommended)

Connect both power cables of the TeraStation to a single UPS device.

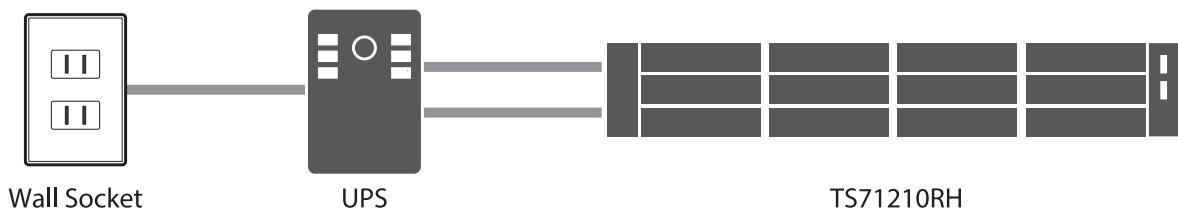

B. To Increase Redundancy for Power Failure

Connect one power cable of the TeraStation to the UPS device and the other to the wall socket. Use separate power supply systems to increase redundancy.

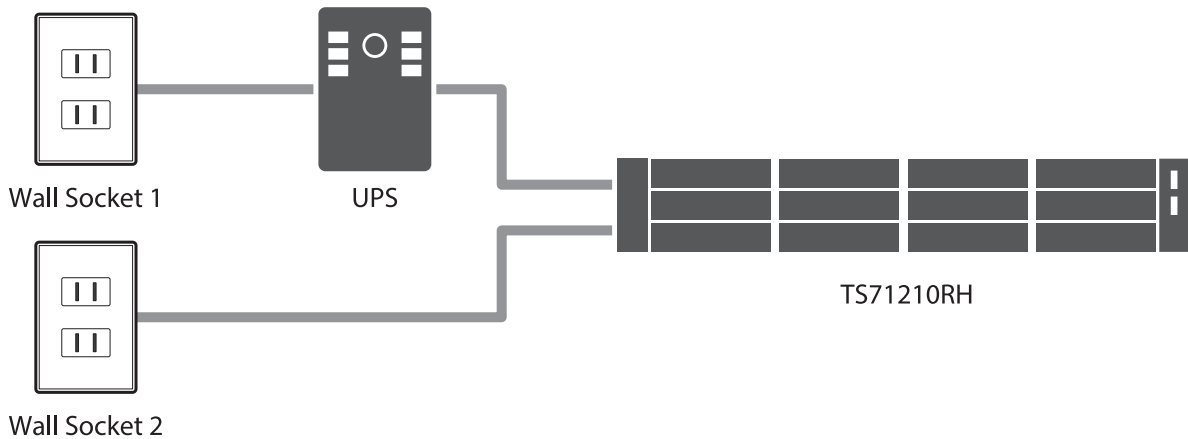

Note: With this connection setup, the option “Wake Up TeraStation After Power Supply Recovers” will not work if it’s configured.

C. To Use Two UPS Devices

Connect a power cable to each of the UPS devices. Use separate power supply systems to increase redundancy. With this connection setup, the UPS devices of the same connection type cannot be used. One should be a USB, another should be a serial connection UPS device. The serial connection UPS device should be converted to a USB connection using a USB-to-serial converter cable.

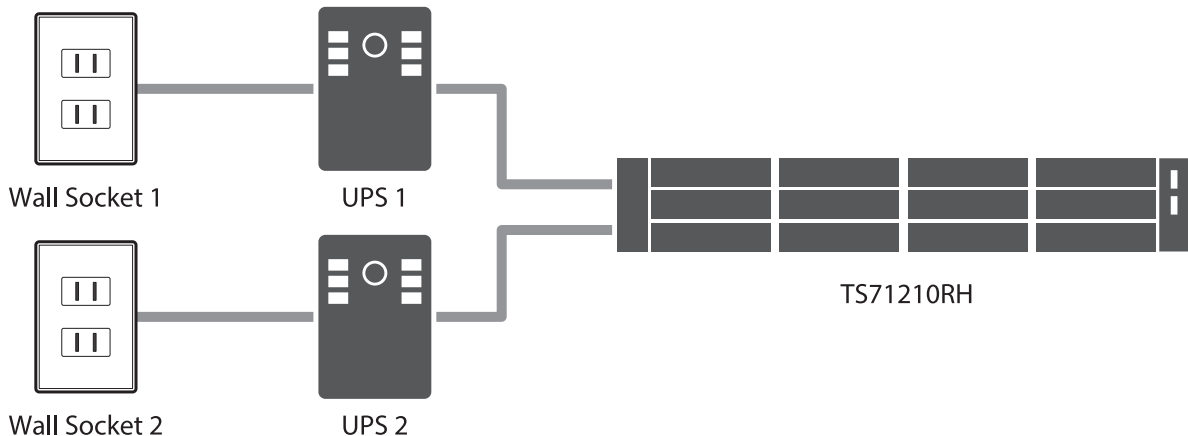

- 1** Connect the UPS device and the TeraStation as described above.
- 2** Turn on the UPS device, then the TeraStation.
- 3** From Settings, click *Management*.

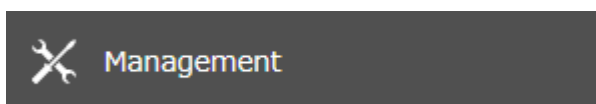

- 4** Click the settings icon (⚙️) to the right of “Power Management”.

⚡ Power Management

⚙️ UPS not synced.

5 Click *Edit* and configure the desired settings, then click *OK*.

6 The process is complete once you close the confirmation window that appears.

Automatic Shutdown If Power Supply Fails

You may configure the TeraStation to shut down automatically if a power supply fails.

1 From Settings, click *Management*.

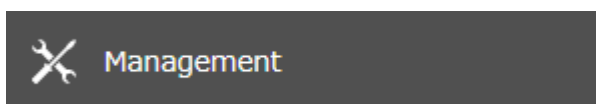

2 Click the settings icon () to the right of "Power Management".



- 3** Click the *Power Supply Failure* tab, then click *Edit*.

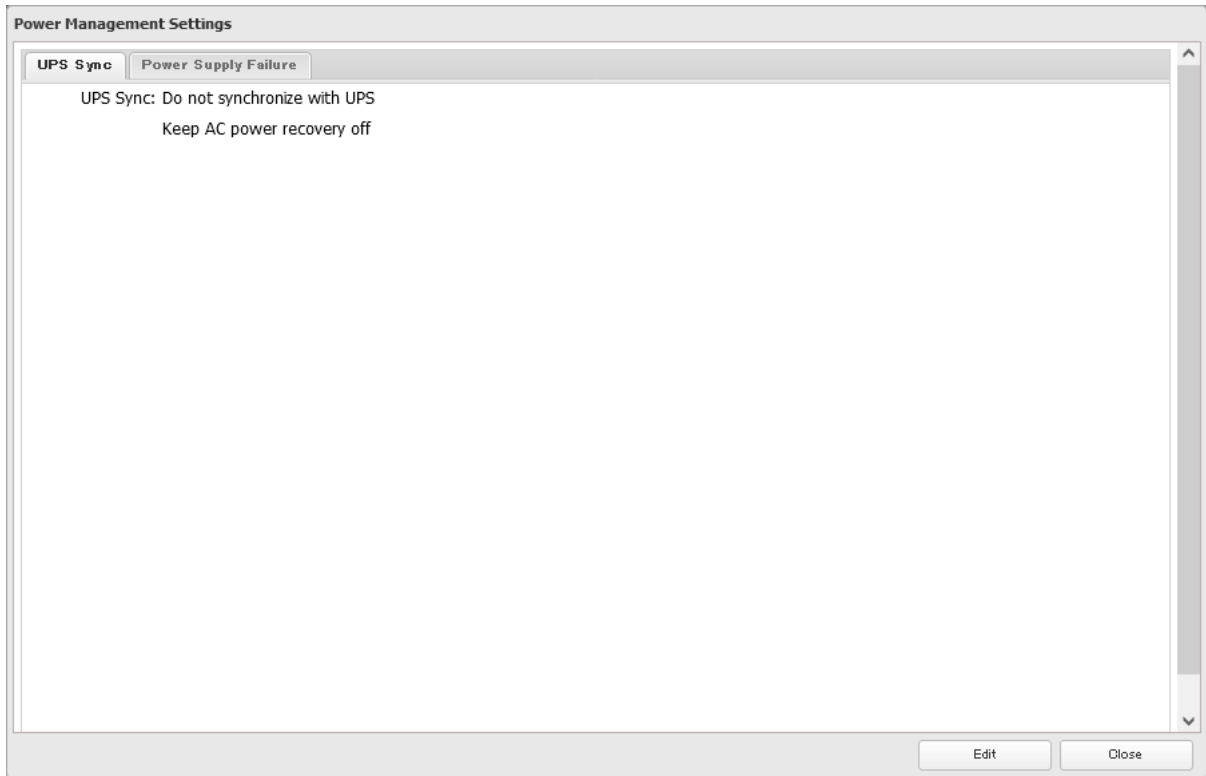

- 4** Select "Shut down TeraStation" and enter the number of minutes that will elapse after the power supply fails before the unit shuts down.

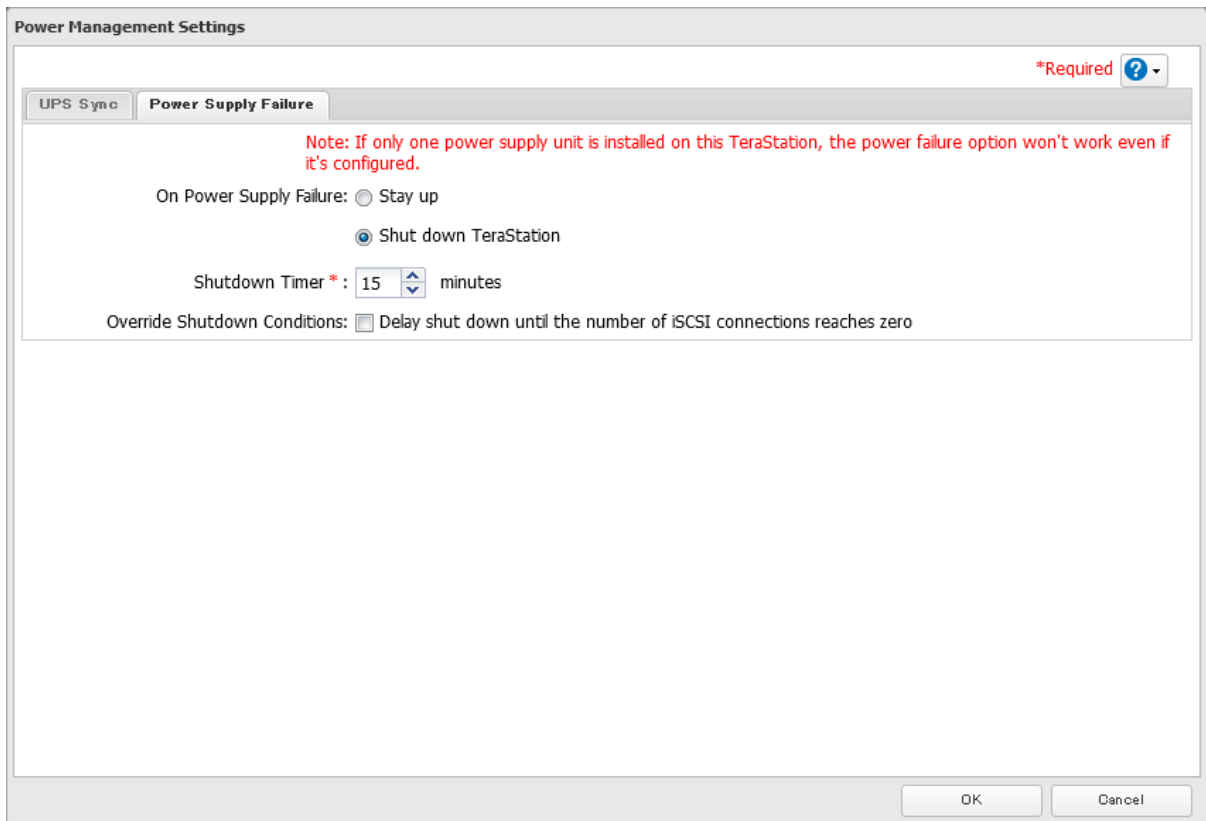

- 5** Click *OK*. The process is complete once you close the confirmation window that appears.

Logs

Displaying TeraStation's Logs

Follow the procedure to check the TeraStation's logs.

- 1 From Settings, click *Management*.

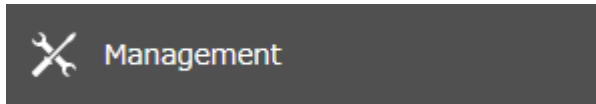

- 2 Click the settings icon () to the right of "Logs".



- 3 Select a log to view.

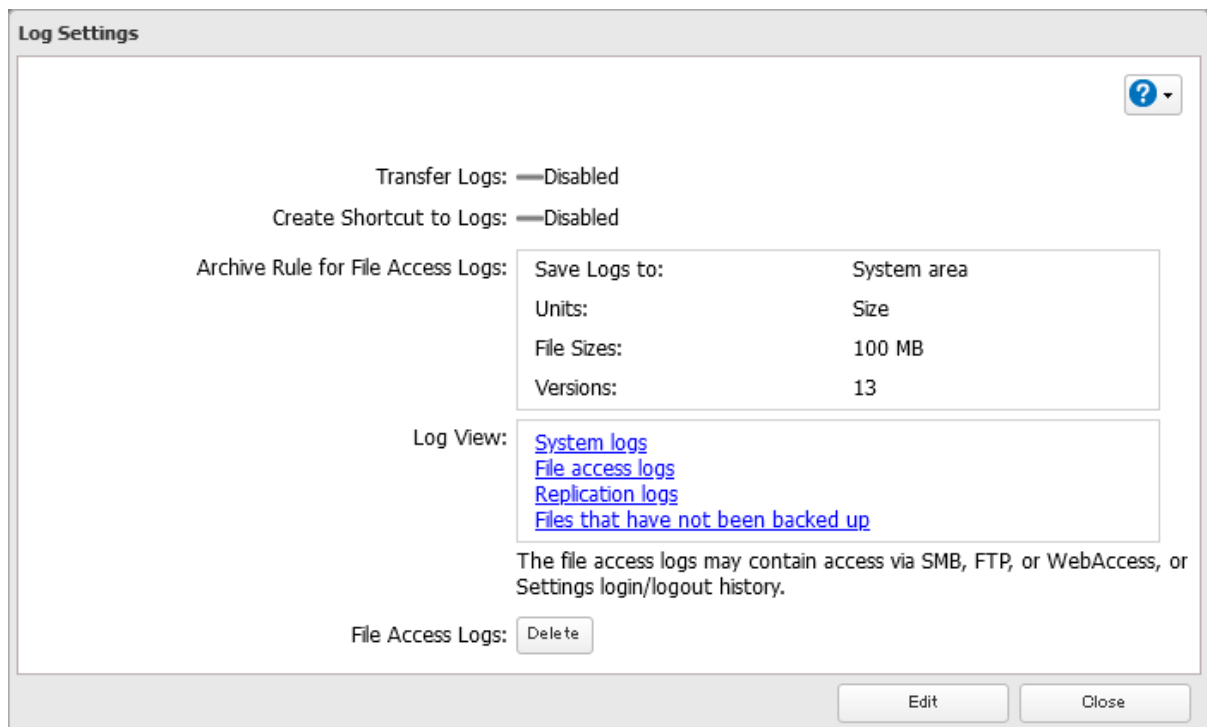

Note: The file access log stores file access events that occurred on the internal drives. File access on USB drives are not logged.

- 4 The process is complete when the selected log is displayed.

Note: All logs are encoded in UTF-8 format. To make sure they display correctly, change the software encoding to "UTF-8".

Transferring Logs to the Syslog Server

- 1 From Settings, click *Management*.

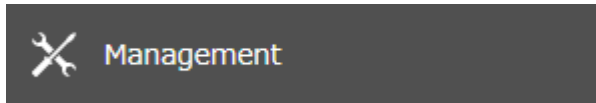

- 2 Click the settings icon () to the right of "Logs".



- 3 Click *Edit* and enable "Syslog Transfer".

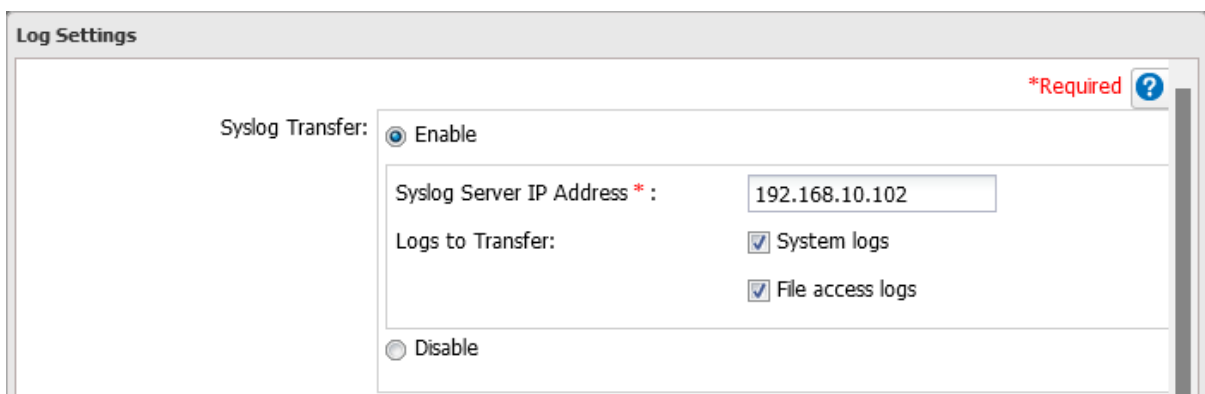

- 4 Enter the IP address of the syslog server where you want to transfer the logs to.
- 5 Select the type of log that you want to transfer from "Logs to Transfer" and click *OK*.
- 6 The process is complete once you close the confirmation window that appears.

Creating a Shortcut to the Logs in the Shared Folder

- 1 From Settings, click *Management*.

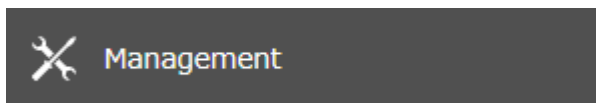

- 2 Click the settings icon () to the right of "Logs".



- 3 Click *Edit* and enable "Create Shortcut to Logs".



- 4 Click *Browse* under “Target Folder” and select the shared folder where the created shortcut will lead, then click *OK*.
- 5 The process is complete once you close the confirmation window that appears.

In the selected shared folder, a folder named “system_log” will now contain the shortcuts to logs.

Changing Archive Rules for File Access Logs

You can configure the number of logs kept or the duration each log is stored on the TeraStation.

- 1 From Settings, click *Management*.

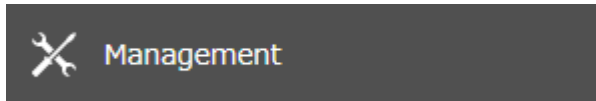

- 2 Click the settings icon () to the right of “Logs”.



- 3 Click *Edit* and specify the location, then select the unit and version to save logs to the right of “Archive Rule for File Access Logs”. For example, if you select “Month” for the unit and enter “7” for the version, the file access logs for the next 7 months will be saved onto the TeraStation.

Available duration and capacity to save logs will vary depending on the unit. The following values are available:

- **Log destination is set to the system area**
Unit (Size): 1–100 for file sizes and 1–13 for all versions
- **Log destination is set to a designated folder**
 - Unit (Day): 1–367 for all versions
 - Unit (Week): 1–53 for all versions
 - Unit (Month): 1–13 for all versions
 - Unit (Size): 1–100 for file sizes and 1–13 for all versions

- 4 Click *OK*. The process is complete once you close the confirmation window that appears.

Notes:

- To delete the saved logs, click *Delete* at the window in step 3.

- If there is not enough space to save logs, the **I70** message will appear as a notification. If it does, free up space by deleting the current file access logs. If no free space is made available elsewhere, older logs will automatically be deleted.
- If the shared folder to which logs are saved was created on a drive or RAID array, and that drive or RAID array is later changed using RMM, the log folder will be automatically changed to the system area. The **I72** message will also appear as a notification.
- You cannot delete a RAID array, format a drive, or change a folder name while file access logs are being saved to the shared folder.

Updating the Firmware

If a new firmware version is available, a message is displayed when you access Settings. To update the firmware manually or automatically, follow the appropriate procedure below.

Notes:

- If all drives and RAID arrays on the TeraStation have LVM enabled but no LVM volumes have been created, you will not be able to update the firmware from Settings.
- Settings will not be available while the firmware is updating. Don't try to access Settings from another computer until the update is finished.

Updating Manually Using Settings

To update the firmware from Settings, follow the procedure below. In such a case, you need free space of 2 GB or more on the TeraStation.

- 1** From Settings, click *Management*.

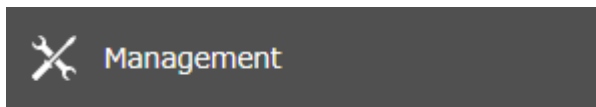

- 2** Click the settings icon () to the right of "Update".

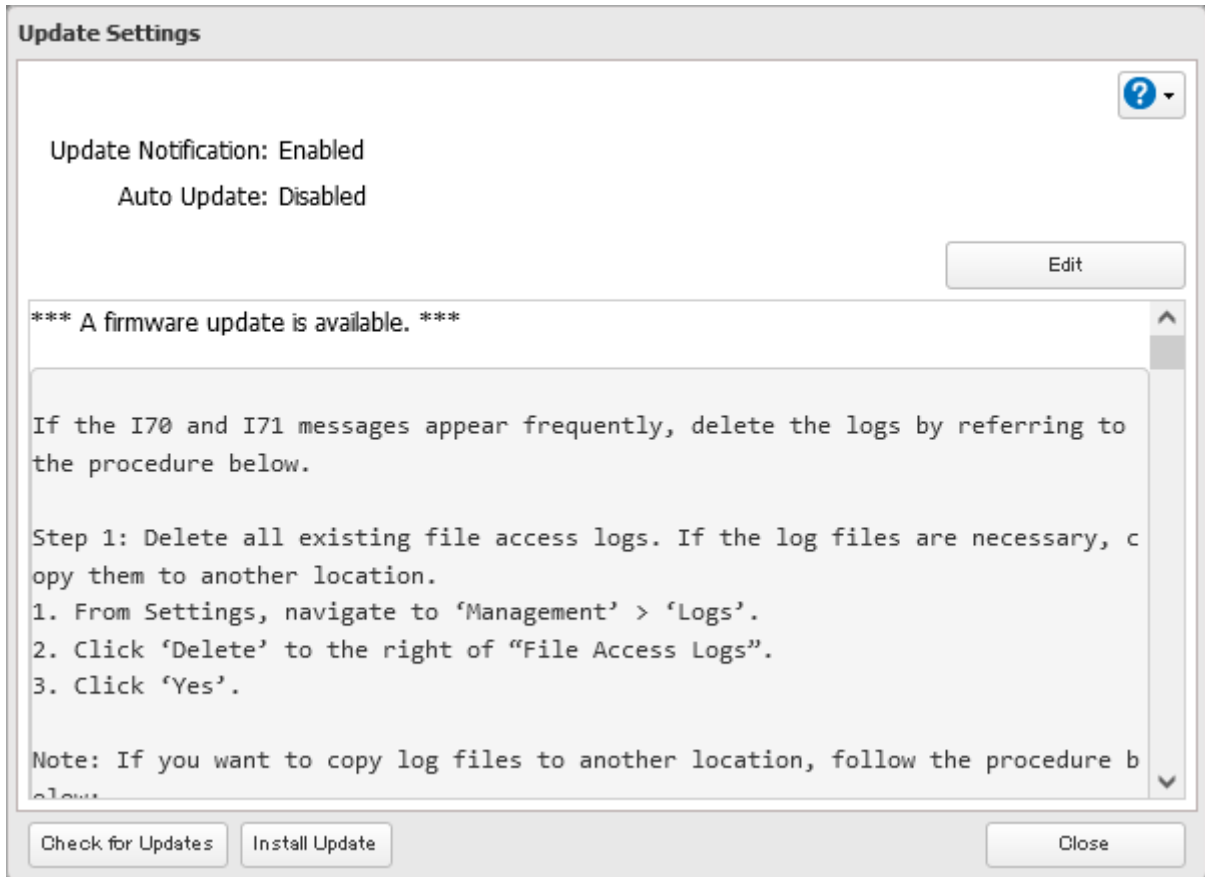

- 3** Click *OK*.

4 Click *Install Update*.

5 The “Confirm Operation” screen will open. Enter the confirmation number, then click *OK*.

6 The process is complete once you close the confirmation window that appears. Refresh the browser and log in to Settings again.

You can also download the latest firmware from the [Buffalo website](#).

Enabling Automatic Update

1 From Settings, click *Management*.

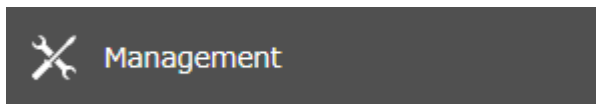

2 Click the settings icon (⚙️) to the right of “Update”.



3 Click *OK*.

- 4** Click *Edit* and select either “Update the firmware automatically” or “Update the firmware on schedule”, then click *OK*.

If you select to update on schedule, choose a specific time of day for the update to occur.

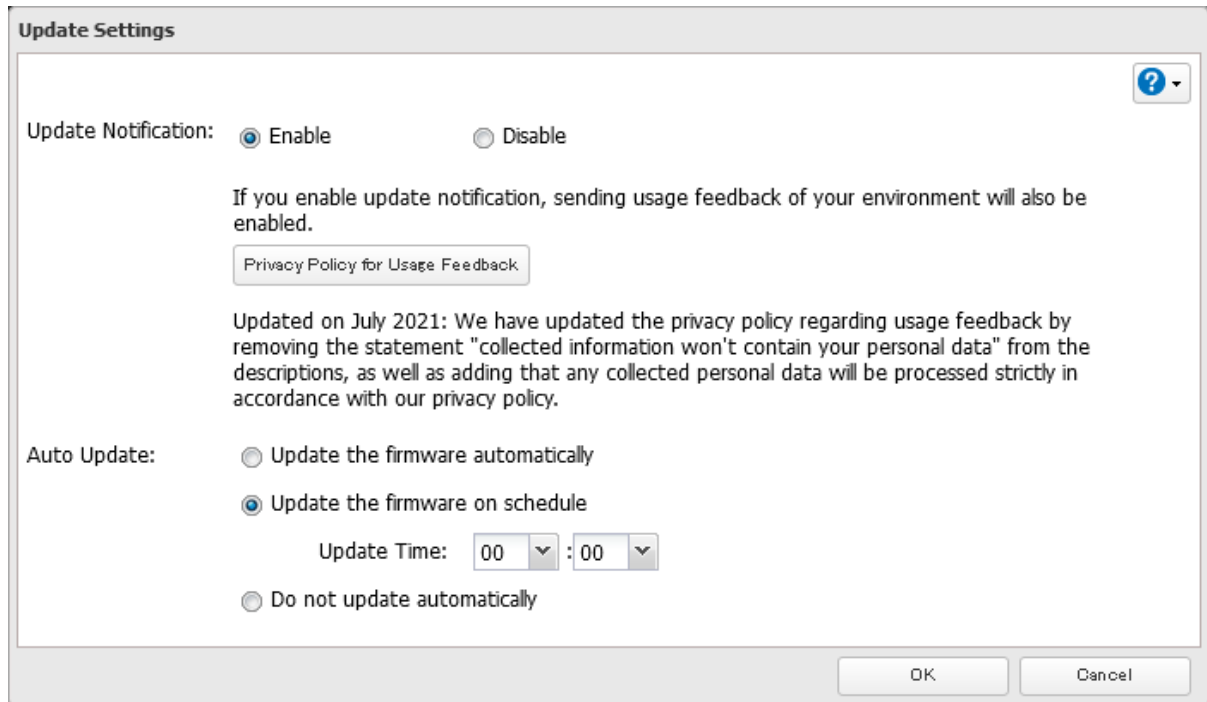

- 5** The process is complete once you close the confirmation window that appears.

Note: If a backup job is in progress when the scheduled update time occurs, automatic update will be skipped. Once backup is complete, auto update will run at the next scheduled time.

Configuring Update Notification

Configure whether or not to receive a notification when a new firmware version becomes available.

- 1** From Settings, click *Management*.

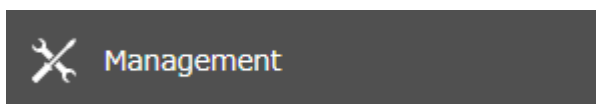

- 2** Click the settings icon () to the right of “Update”.



- 3** Click *OK*.

- 4** Click *Edit* and select whether to enable or disable update notification, then click *OK*.

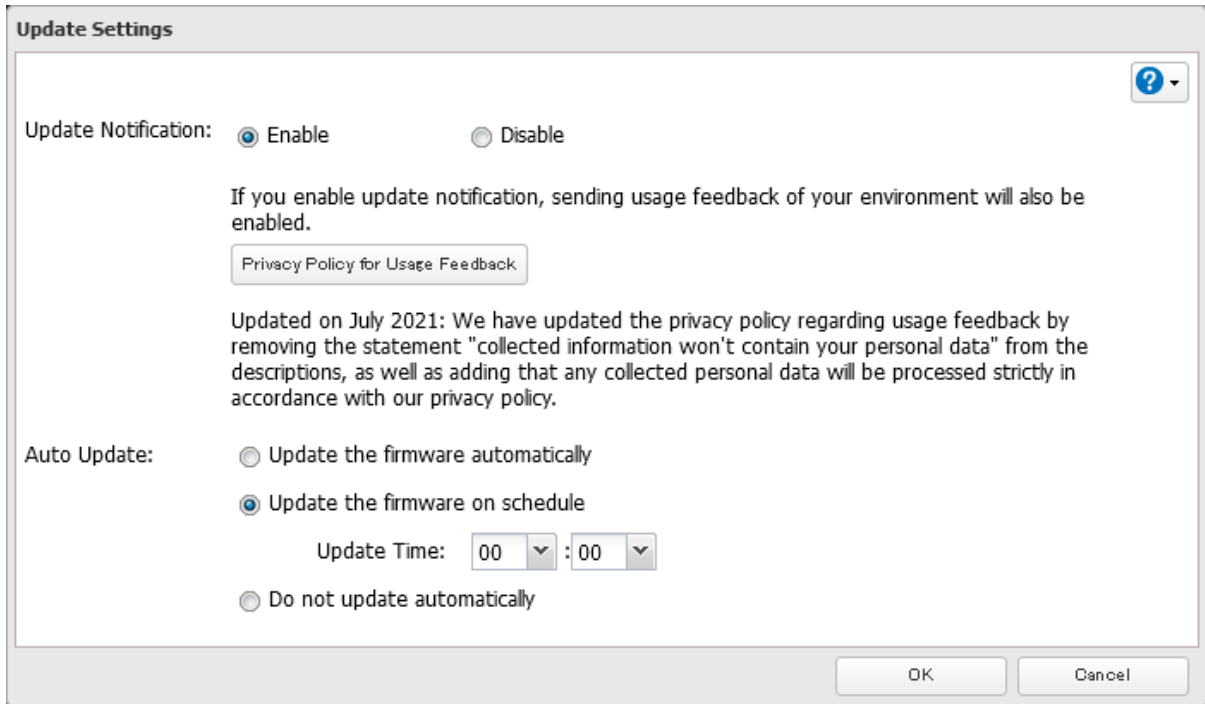

- 5** The process is complete once you close the confirmation window that appears.

For further optimized firmware updates and product usability improvements, Buffalo may ask you to send your usage and environment information. For more details such as the information sent and how it will be handled by us, click *Privacy Policy for Usage Feedback*.

If update notification is enabled, it will also automatically enable sending usage feedback to Buffalo. If you don't want to send this information to us, disable update notification.

Name, Date, Time, and Language

Configure the TeraStation's hostname, date, time, and language as shown below.

Note: To change the settings of a TeraStation that is being used as an iSCSI drive, navigate to *Storage > iSCSI* in Settings and move the iSCSI switch to the **off** position temporarily before changing settings.

- 1** From Settings, click *Management*.

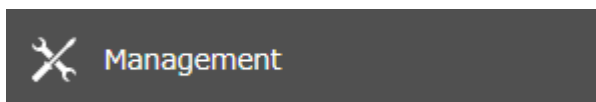

- 2** Click the settings icon () to the right of "Name/Time/Language".



3 From the *Name* tab, click *Edit*, then enter the TeraStation's name and description.

The name will be used for identifying your TeraStation on the network. When your TeraStation is detected, the name will be used as the hostname. The hostname may contain up to 15 alphanumeric characters and hyphens (-). The first and last characters should not be a hyphen; do not use the following word as a hostname: localhost.

The screenshot shows the 'Name/Time/Language Settings' dialog box with the 'Name' tab selected. The 'Name' field contains 'TS71210R078' and the 'Description' field contains 'TeraStation'. There are 'OK' and 'Cancel' buttons at the bottom right. A red '*Required' label and a help icon are visible in the top right corner.

4 Click the *Time* tab. Enable "Date/Time Source" and select the "Use default NTP server" checkbox. If you disable the NTP function, click *Use Local Date/Time* to use your computer's time settings for the TeraStation.

The screenshot shows the 'Name/Time/Language Settings' dialog box with the 'Time' tab selected. The 'Date/Time Source' section has 'Enable' selected. The 'NTP IP Address' field contains 'ntp.jst.mfeed.ad.jp', the 'Use default NTP server' checkbox is checked, and the 'NTP Synchronization Frequency' is set to 'Every day'. The 'Disable' section is greyed out, showing a date of '08/22/2024' and a time of '3 : 52 : 22'. The 'Time Zone' dropdown is set to '(UTC-06:00) Central Time (US & Canada)'. There are 'OK' and 'Cancel' buttons at the bottom right. A red '*Required' label and a help icon are visible in the top right corner.

By default, the TeraStation adjusts its clock automatically by using a default NTP server. This NTP server belongs to Internet Multi Feed Inc. For more information, visit <http://www.jst.mfeed.ad.jp>.

To use a different NTP server, clear the "Use default NTP server" checkbox and enter a new NTP IP address or its hostname, then click *OK*. If an NTP server is specified by name instead of IP address, make sure that a DNS server is configured for the TeraStation.

Note: The internal clocks of the TeraStation and other devices on your network may run at slightly different speeds. Over a long period of time, your network devices may show somewhat different times, which can cause network problems. If clocks on your network vary by more than five minutes, unexpected behavior may occur. For best results, keep all clocks on your network devices set to the same time by adjusting them regularly, or use an NTP server to correct them all automatically.

- 5** Click the *Language* tab and select the language to be used.

The screenshot shows a dialog box titled "Name/Time/Language Settings". It has four tabs: "Name", "Time", "Language", and "Management Information". The "Language" tab is active. In the top right corner, there is a red asterisk followed by the word "Required" and a question mark icon. Below the tabs, there are two dropdown menus: "Character Encoding" set to "CP437" and "Display Language" set to "English". At the bottom right, there are "OK" and "Cancel" buttons.

Note: This tab changes the language used by the TeraStation for email notifications and other functions. To change the language displayed in Settings, go to Settings and click *Language* from the menu bar. Choose your desired language from the drop-down list.

- 6** Click the *Management Information* tab. Enter the desired location and administrator information.

The screenshot shows the same dialog box as above, but with the "Management Information" tab selected. The "Character Encoding" and "Display Language" fields are no longer visible. Instead, there are two text input fields: "Location:" and "Administrator:". The "Required" indicator and "OK/Cancel" buttons remain the same.

- 7** Click *OK* when all settings are configured.

- 8** The process is complete once you close the confirmation window that appears.

Beep Alerts

You can set the TeraStation to beep if certain errors occur.

- 1** From Settings, click *Management*.

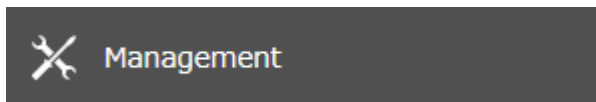

- 2** Click the settings icon () to the right of "Notifications".



- 3** Click the *Alert Sounds* tab, then click *Edit*.

4 Select the triggers that make the alert beep, then click *OK*.

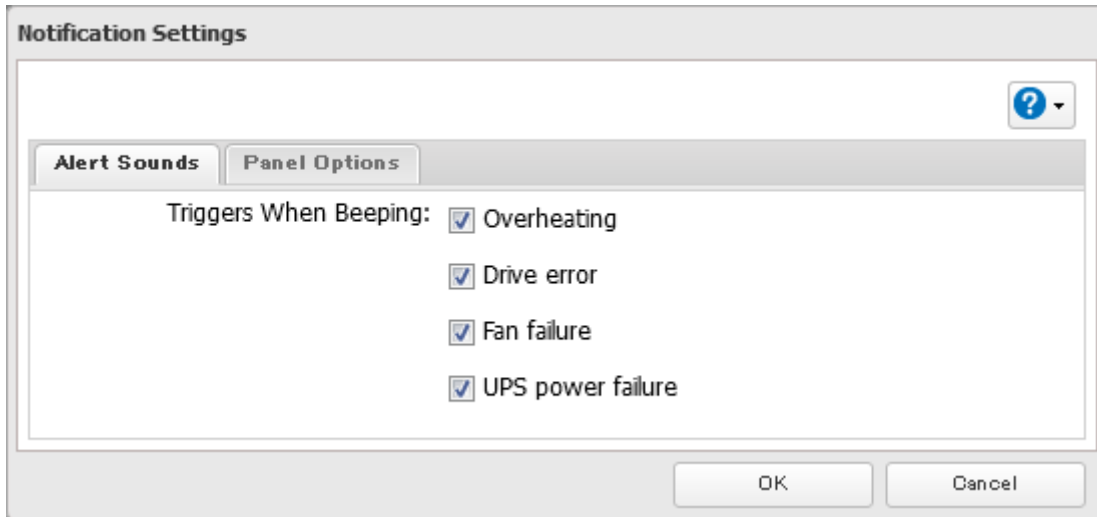



5 The process is complete once you close the confirmation window that appears.

LEDs

You may adjust the brightness of the LEDs on the TeraStation.

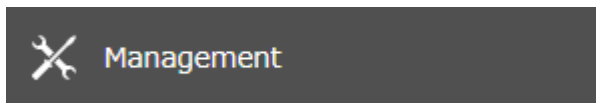
1 From Settings, click *Management*.



2 Click the settings icon () to the right of "Notifications".



3 From the *Panel Options* tab, click *Edit* and configure your desired settings, then click *OK*.

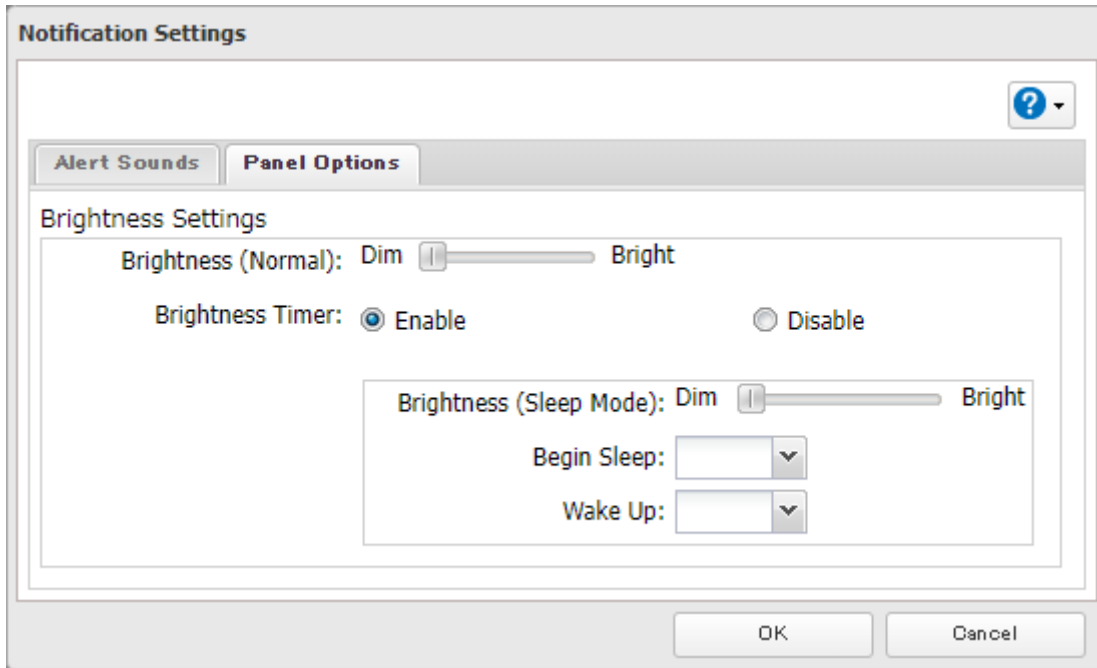

4 The process is complete once you close the confirmation window that appears.

Chapter 12 Drive Replacement and Device Troubleshooting

Replacing a Defective Drive

Drive replacement procedures will vary depending on which RAID mode is configured for the TeraStation. Refer to the appropriate replacement procedure in the following sections that corresponds to the configured RAID mode.

LEDs

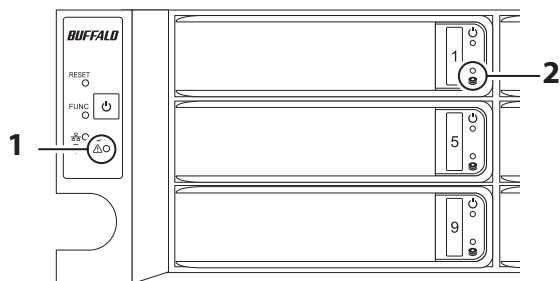

1 Error LED

Glows red if a drive has failed.

2 Drive Error LED

The failed drive's error LED will be blinking if the drive is still mounted. It will turn to a glowing red after the drive is dismounted.

Notes

- Use a Buffalo OP-HDH2U series drive as the replacement drive. The replacement drive should be the same capacity or larger as the original drive. If a larger drive is used, the extra space will not be usable in a RAID array.
- To avoid damaging the TeraStation with static electricity, ground yourself by touching something made of metal before handling any sensitive electronic parts.
- After a drive is replaced, it will take about 30 minutes before normal file reading and writing operations are restored. Settings may not be accessible during this period.
- Do not change the order of the drives on the TeraStation. For example, pulling out the drive in slot 1 and replacing it with the drive in slot 2 may cause data to be corrupted or lost.
- If the LEDs do not change after a new drive is installed, click *Redetect Drive* in Settings.

Drive Replacement for a Redundant RAID Array

If a drive used in a redundant RAID array fails, you will need to recover the RAID array after replacing the defective drive with a new drive. Follow the procedure below to replace a defective drive used in a redundant RAID array.

- 1 Back up the saved data to another location before replacing the failed drive. If one or more drives fail during drive replacement, data can no longer be retrieved from the TeraStation.

2 The failed drive's error LED will be glowing red. Push its unlock button and swing the lock mechanism out.

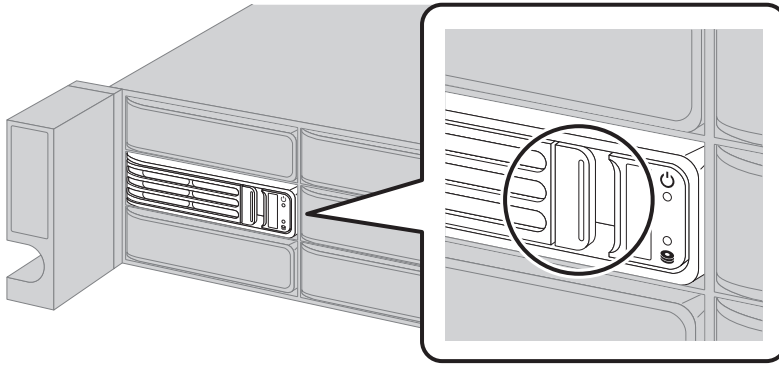

3 Pull out the drive cartridge and remove it from the TeraStation.

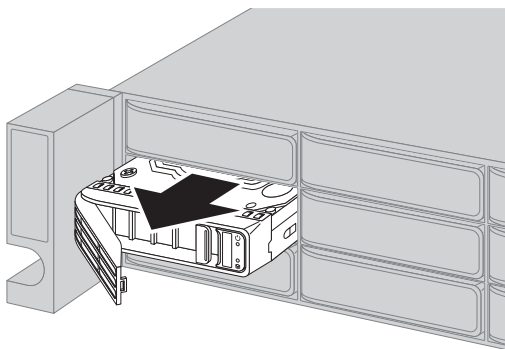

4 Insert the new drive into the empty slot with the lock mechanism remaining open.

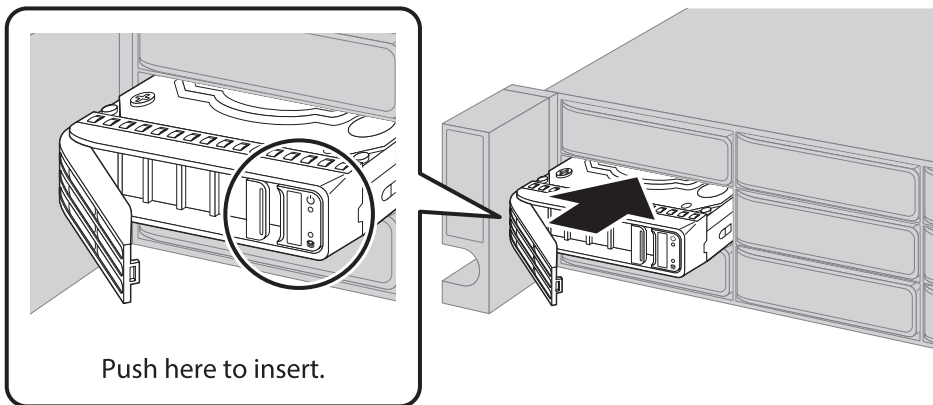

5 Swing the lock back down until it clicks into place.

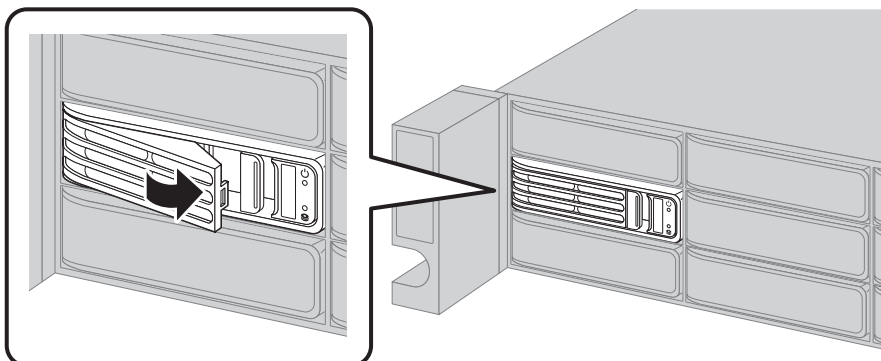

- 6** If the TeraStation's power is off, press the power button.
- 7** When the replaced drive is recognized, the error LED will blink and the **I31** message will appear as a notification.
- 8** The replaced drive will be rebuilt into the RAID array automatically when auto RAID rebuild is enabled. If not, you will have to rebuild the RAID array from Settings.
 - (1) From Settings, navigate to *Storage > RAID*.
 - (2) Click the RAID array that held the failed drive, then select the replaced drive and click *Recover RAID Array*.
- 9** The RAID array recovery will begin. The **I18** message will appear as a notification after five minutes. The process is complete when the **I18** message disappears.

Drive Replacement for a RAID 0 Array

If a drive used in a RAID 0 array fails, you will need to create a RAID array again after replacing the defective drive with a new drive. Follow the procedure below to replace a defective drive used in a RAID 0 array.

Note: If a drive in a RAID 0 array malfunctions, all data on the RAID array will be lost. All of the settings for the shared folders (such as access restrictions) are erased after replacing a drive from a RAID 0 array.

- 1** Delete the RAID array that held the failed drive by referring to the ["Using JBOD"](#) section in chapter 5.
- 2** Dismount the drive with the blinking error LED by referring to the ["Dismounting Drives"](#) section in the same chapter.
- 3** The error LED will stop blinking and glow steadily. Push its unlock button and swing the lock mechanism out.
- 4** Pull out the drive cartridge and remove it from the TeraStation.
- 5** Insert the new drive into the empty slot with the lock mechanism remaining open.
- 6** Swing the lock back down until it clicks into place.
- 7** When the replaced drive is recognized, the error LED and drive status LED will blink alternately and the **I32** message will appear as a notification.
- 8** Format the replaced drive by referring to the ["Formatting Drives"](#) section in chapter 5.
- 9** Create a new RAID 0 array by referring to the ["Creating a RAID Array"](#) section in the same chapter.
- 10** The process is complete once the new RAID 0 array is created. Next, create a shared folder by referring to the ["Adding a Shared Folder"](#) section in chapter 4.

Drive Replacement for a JBOD

If a drive used as a JBOD fails, you will need to format the replaced drive after replacing the defective drive with a new drive. Follow the procedure below to replace a defective drive used as a JBOD.

Note: If a drive in a JBOD malfunctions, all data on the drive will be lost.

- 1** The failed drive's error LED will be glowing red. Push its unlock button and swing the lock mechanism out.
- 2** Pull out the drive cartridge and remove it from the TeraStation.

- 3** Insert the new drive into the empty slot with the lock mechanism remaining open.
- 4** Swing the lock back down until it clicks into place.
- 5** When the replaced drive is recognized, the error LED will blink and the **I31** message will appear as a notification.
- 6** Format the replaced drive by referring to the [“Formatting Drives”](#) section in chapter 5.
- 7** The process is complete once the drive is formatted. Next, create a shared folder by referring to the [“Adding a Shared Folder”](#) section in chapter 4.

Drive Replacement for a Hot Spare

If your TeraStation's drives are in a redundant RAID mode and you have a hot spare enabled, a malfunctioning drive in the array is replaced with a hot spare and the RAID array is rebuilt automatically. The error LED will continue to glow red for the failed drive even after the RAID array is rebuilt with the hot spare. After you replace the failed drive with a new drive, follow the procedure below to configure the new drive as a hot spare.

- 1** The failed drive's error LED will be glowing red. Push its unlock button and swing the lock mechanism out.
- 2** Pull out the drive cartridge and remove it from the TeraStation.
- 3** Insert the new drive into the empty slot with the lock mechanism remaining open.
- 4** Swing the lock back down until it clicks into place.
- 5** When the replaced drive is recognized, the error LED will blink and the **I31** message will appear as a notification.
- 6** Press the function button.
- 7** The process is complete when the TeraStation beeps. The replaced drive will be automatically registered as a hot spare.

If you want to use the replaced drive as a normal drive rather than a hot spare, navigate to *Storage > RAID* and click the RAID array, select the new drive, and click *Set as a normal drive*.

Replacing a Non-Malfunctioning Drive

If you must change a drive that is not malfunctioning, replace it by referring to the appropriate section below that corresponds to the RAID mode being used. If you need to replace multiple drives, replace them one at a time to preserve your data.

Operating in a Redundant RAID Array

If you are using a redundant RAID mode such as RAID 1, 5, or 6, the RAID array will enter degraded mode after replacing the drive. You will be unable to use the TeraStation until you recover the RAID array with a new drive. To recover the RAID array:

- (1) Dismount the drive by referring to the [“Dismounting Drives”](#) section in chapter 5, then disconnect the drive.
- (2) Insert a new drive and format it by referring to the [“Formatting Drives”](#) section in the same chapter.
- (3) Refer to the [“Drive Replacement for a Redundant RAID Array”](#) section above and follow the procedure from step 8 on.

Operating in RAID 0

All data on the RAID array will be deleted after replacing the drive. You will be unable to use the TeraStation until you create a new RAID array with a new drive. To create a new RAID array:

- (1) First, delete the RAID array by referring to the [“Using JBOD”](#) section in chapter 5.
- (2) Dismount the drive by referring to the [“Dismounting Drives”](#) section in the same chapter, then disconnect the drive.
- (3) Insert a new drive and format it by referring to the [“Formatting Drives”](#) section in the same chapter.
- (4) Finally, create a new RAID array by referring to the [“Creating a RAID Array”](#) section in the same chapter.

Operating in JBOD

All data on that drive will be deleted after replacing the drive. You will be unable to use the TeraStation until you format a new drive. To format a drive:

- (1) Dismount the drive by referring to the [“Dismounting Drives”](#) section in chapter 5, then disconnect the drive.
- (2) Insert a new drive and format it by referring to the [“Formatting Drives”](#) section in the same chapter.

Re-Inserting Drives

If the E14 or E16 error appears as a notification after initial bootup, follow the procedure below to re-insert the internal drives.

- 1** Turn off the TeraStation.
- 2** Push a drive's unlock button and swing the lock mechanism out.

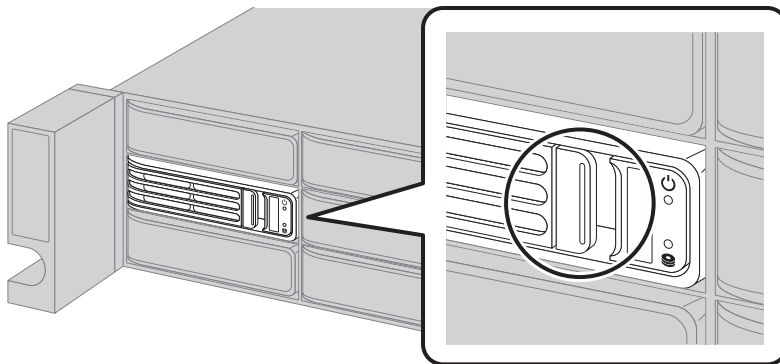

- 3** Pull out the drive cartridge and remove it from the TeraStation.
- 4** Insert the drive back into the same slot with the lock mechanism remaining open.

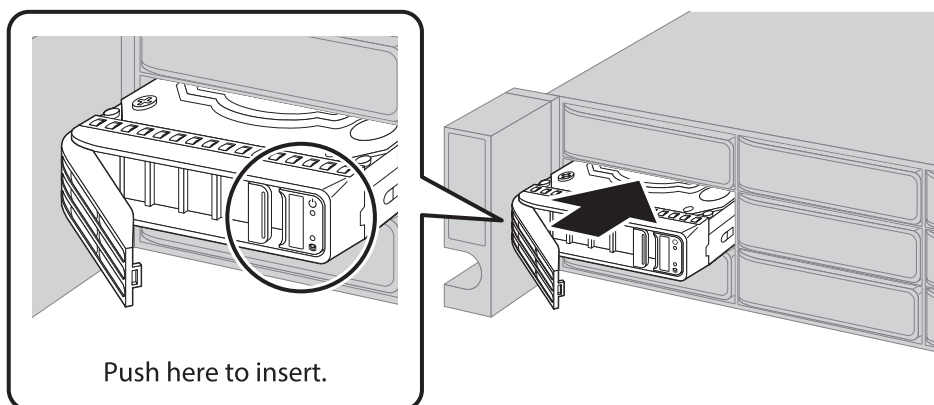

- 5** Swing the lock back down until it clicks into place.

- 6 Repeat steps 3–6 for all other installed drives.
- 7 Press the power button on the TeraStation.
- 8 The process is complete when any error messages disappear.

TeraStation Does Not Work Properly

If an error occurs that prevents the TeraStation from booting up properly, one or more of the following symptoms may occur. In such a case, try the corresponding corrective action to recover from the error, described in each section below. If the error is still not resolved, contact Buffalo technical support for assistance.

- The power LED keeps blinking instead of turning into a solid glow; follow the procedure at the [“Power LED Keeps Blinking”](#) section below.
- An “i” symbol is displayed with the TeraStation icon and the I61 message appears as a notification; follow step 3 and after at the [“Power LED Keeps Blinking”](#) section below.
- An “i” symbol is displayed with the TeraStation icon and “EM” is added to your TeraStation’s hostname on NAS Navigator2; follow the procedure at the [“Booting the TeraStation in Emergency Mode”](#) section below.

Power LED Keeps Blinking

While the TeraStation’s power LED keeps blinking, you may see the I61 message. In such a case, follow the procedure below to recover from drive setup mode.

- 1 Press and hold down the power button for three seconds to turn off the TeraStation.
If the TeraStation is still on, press and hold down the power button for more than 10 seconds to forcibly shut it down.
- 2 Turn the TeraStation back on while holding down the function button. You should hold down the function button for at least 10 seconds after pressing the power button.
- 3 When the power LED changes from blinking to glowing, release the function button and open Settings from NAS Navigator2.
- 4 Make sure that “Recover firmware” is selected from the drop-down list under “Action”, then click *Start Setup*.

Unit Firmware Version : 1.00-1.16

Drive	Status	Info	Version	Model Name	Capacity	Primary Drive	Action
Drive 1	Recognized	System#1_(D:1/12)	1.00-1.16	HGST_HUS724020ALA640	1863 GB	⊙	Recover firmware ▾
Drive 2	Recognized	System#1_(D:2/12)	1.00-1.16	HGST_HUS724020ALA640	1863 GB		Recover firmware
Drive 3	Recognized	System#1_(D:3/12)	1.00-1.16	HGST_HUS724020ALA640	1863 GB		Recover firmware
Drive 4	Recognized	System#1_(D:4/12)	1.00-1.16	HGST_HUS724020ALA640	1863 GB		Recover firmware
Drive 5	Recognized	System#1_(D:5/12)	1.00-1.16	HGST_HUS724020ALA640	1863 GB		Recover firmware
Drive 6	Recognized	System#1_(D:6/12)	1.00-1.16	HGST_HUS724020ALA640	1863 GB		Recover firmware
Drive 7	Recognized	System#1_(D:7/12)	1.00-1.16	HGST_HUS724020ALA640	1863 GB		Recover firmware
Drive 8	Recognized	System#1_(D:8/12)	1.00-1.16	HGST_HUS724020ALA640	1863 GB		Recover firmware

Redetect Drive Start Setup

Secure Erase
This will erase data securely from all drives on this TeraStation. For more detailed information about this feature, refer to the [user manual](#).
To start erasing data, click 'Start Secure Erase'. To check data erasure history, click 'View Log'.

View Log Start Secure Erase

Note: There are two more options for “Action” other than “Recover firmware”. The details for all options are below:

- **Use the drive's firmware:** The TeraStation will boot using the firmware on the drive.
- **Recover firmware:** The TeraStation will be recovered using the firmware on the NAND flash.
- **Format drive:** The drive will be formatted.

5 The “Confirm Operation” screen will open. Enter the confirmation number, then click *OK*.

6 The recovery process will start. When the process is finished, click *OK*.

7 The TeraStation will shut down automatically. Press the power button to turn it on.

8 The process is complete when the power LED turns from blinking to glowing.

The TeraStation will be recovered from the malfunction that is keeping the power LED blinking. Make sure the TeraStation finishes booting properly.

Notes:

- If the TeraStation does not recover from the error after trying the procedure above, try again from the first step.
- If the TeraStation did not power off properly in the previous shutdown, a message will appear in the window as below:

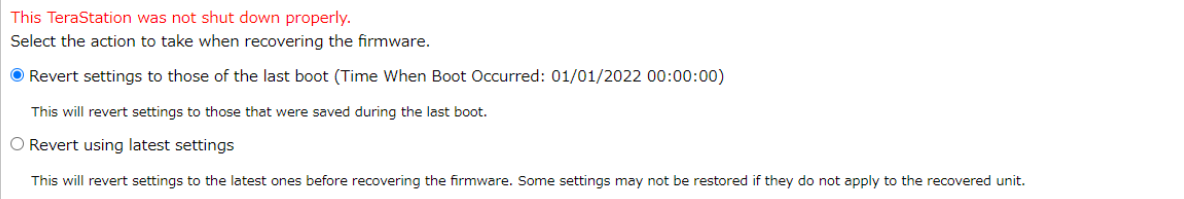

Booting the TeraStation in Emergency Mode

If the TeraStation boots up in emergency mode, depending on your TeraStation model, an “i” symbol is displayed with the TeraStation icon and “EM” is added to your TeraStation’s hostname.

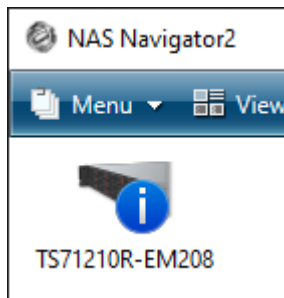

To recover from emergency mode, follow the procedure below.

- 1** Download the firmware updater from the [Buffalo website](#).
- 2** Extract the downloaded file by double-clicking it and launch the updater.
- 3** Update the firmware for the TeraStation unit that is currently in emergency mode.

When the “i” symbol and “EM” disappear from the icon and the hostname on NAS Navigator2, the TeraStation is no longer in emergency mode.

Note: If the TeraStation is not shut down properly, due to reasons such as a power outage or the power cable getting disconnected while the TeraStation is on, data on the TeraStation may be corrupted when the TeraStation boots in emergency mode. In such a case, the corrupted data may not be recoverable even if you try the procedure above.

Unable to Access Shared Folders

If you cannot access a shared folder, check the following aspects:

- The logged-in user information has been added to Windows network credentials.
- The folder owner and access permissions have been configured properly.
- The SMB protocol is suited to your environment.

To configure the TeraStation to have the network credentials window appear when accessing a shared folder, refer to the [“Opening the Network Credentials Window”](#) section. If the folder owner and access permissions have accidentally been changed to incorrect parameters, restore them by referring to the [“Restoring Owner and Permission Settings”](#) section. If you have changed the SMB protocol settings from the factory default value (“Auto”), refer to the [“Configuring Compatible SMB Protocols”](#) section.

Opening the Network Credentials Window

Due to security reasons, you may be unable to access shared folders from computers running certain Windows versions. In such a case, follow the procedure below to change the TeraStation settings so you can be prompted to enter a Windows credential.

- 1 From Settings, click *File Sharing*.

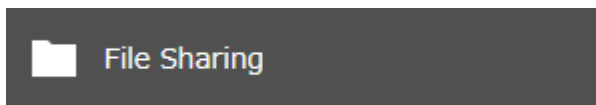

- 2 Click the settings icon () to the right of “SMB”.



- 3 Click *Edit* and change the “Network Credentials” option to “Show network credentials window”, then click *OK*.

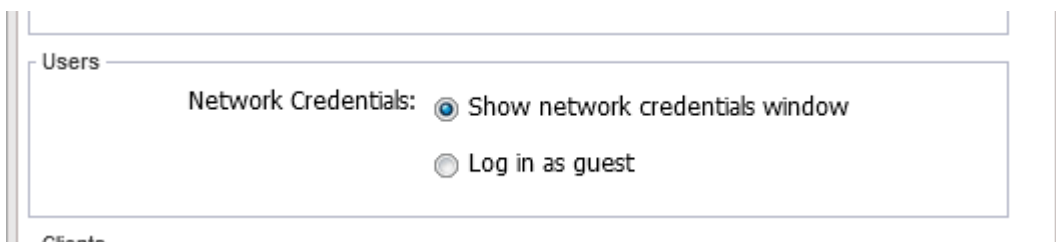

- 4 The process is complete when the file sharing menu list is displayed.

The settings are now changed. A window to enter a username and password will appear the next time you access a shared folder but fails.

Restoring Owner and Permission Settings

If you changed the owner to an unexpected user or accidentally lost permissions to a specific folder, you can follow the procedure below to restore them.

1 From Settings, click *File Sharing*.

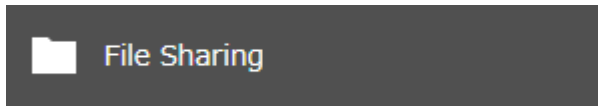

2 Click the settings icon () to the right of "Folder Setup".



3 Click *Advanced Settings for Subfolders*.

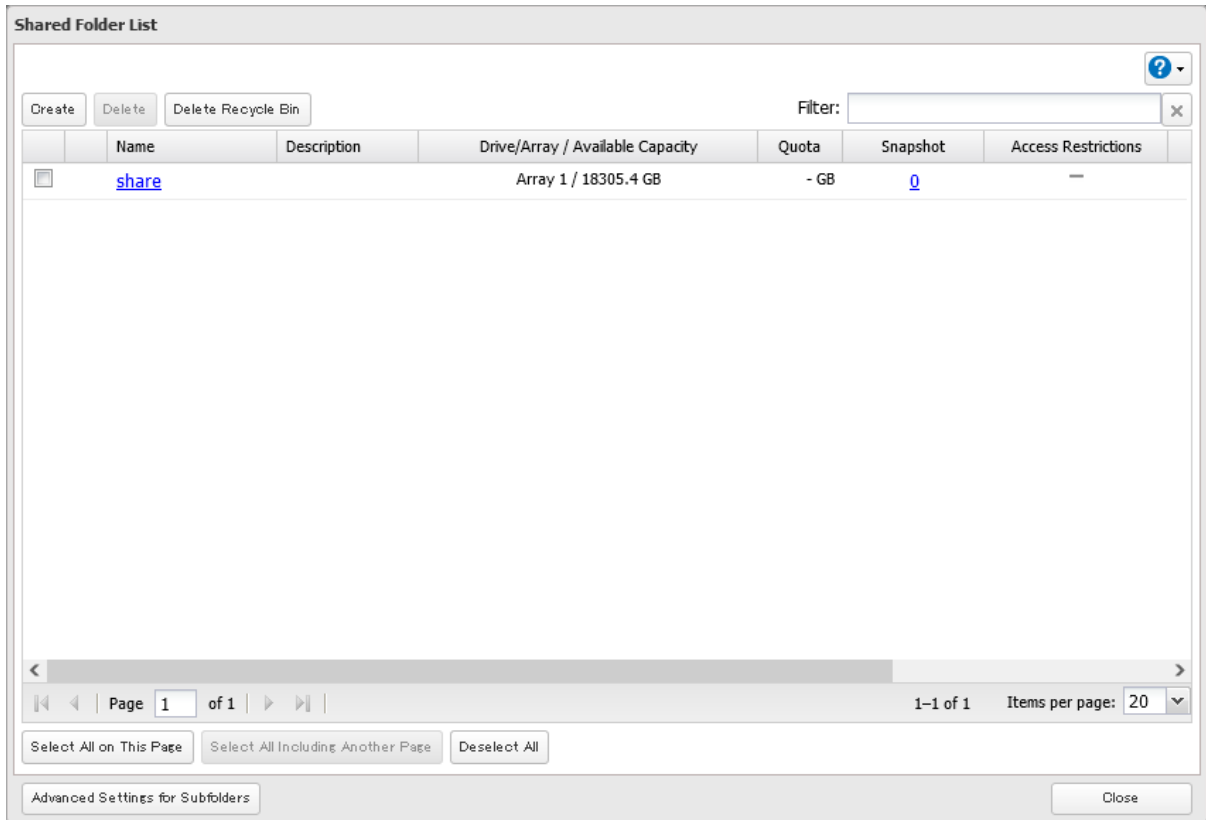

4 Select a folder to restore permissions from the tree.

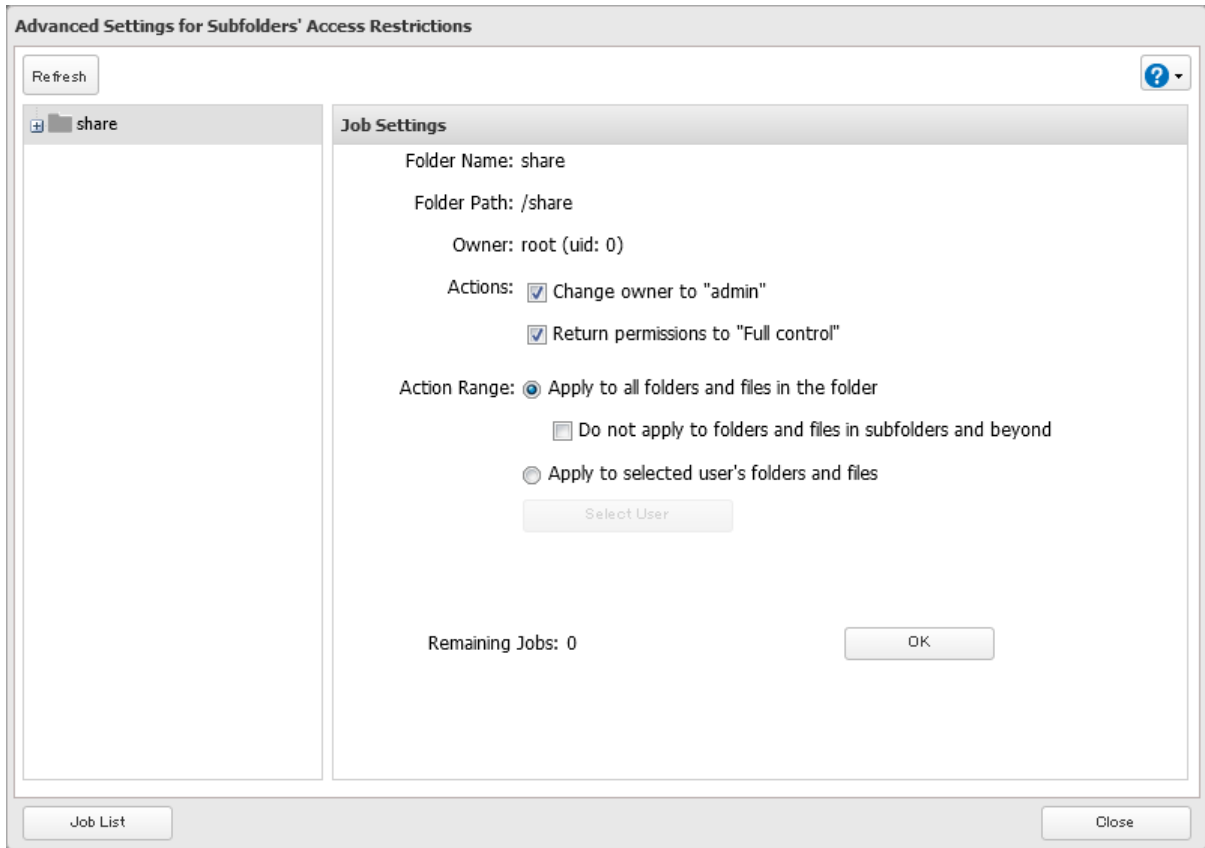

Note: If you select a root shared folder from the tree, the action will not apply to the recycle bin. To apply the action to the recycle bin, select it instead.

5 Select the actions and action range to run, then click *OK*.

6 The “Confirm Operation” screen will open. Enter the confirmation number, then click *OK*.

7 The process is complete once you close the confirmation window that appears.

Configuring Compatible SMB Protocols

You can change the SMB protocols that the TeraStation supports depending on the environment of your SMB clients.

Note: If you select SMB2 for this setting, the TeraStation will not be accessible from a client that uses SMB 2.0 protocol. In such a case, access the TeraStation from an SMB 2.1 protocol client or change the compatible SMB version.

1 From Settings, click *File Sharing*.

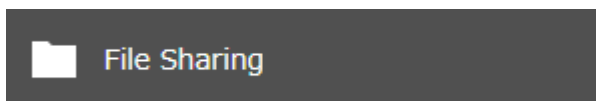

2 Click the settings icon () to the right of “SMB”.



3 Click *Edit* and change the “Protocol Selection” option to “Manual”.

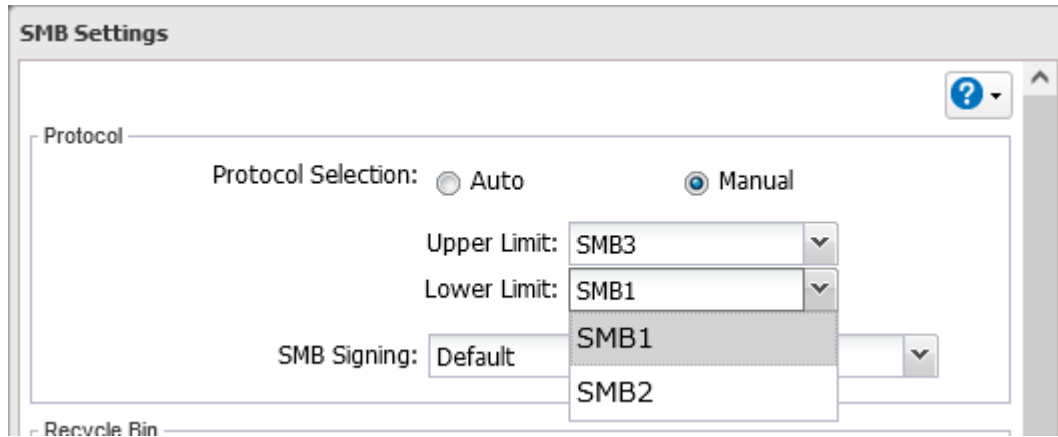

4 Select the upper and lower SMB protocols and click *OK*.

5 The process is complete when the file sharing menu list is displayed.

Chapter 13 Utilities

NAS Navigator2

NAS Navigator2 is a utility program that makes it easy to display Settings, change the Buffalo NAS device's IP address, or check its drives. To install NAS Navigator2, refer to the appropriate procedure below for your computer.

Windows

The NAS Navigator2 installer for a Windows computer is available from the d.buffalo website, accessible from <https://d.buffalo.jp/TS71210RH/>.

Once you have accessed the URL, select the region and model to go to your specific model's d.buffalo website. Download the NAS Navigator2 installer and install the utility onto your computer.

Refer to the software help for more detailed information on operating the software. To open the help, launch NAS Navigator2 and navigate to *Menu > Help*.

macOS

The NAS Navigator2 app for a macOS computer is available from Mac App Store. Download the app and install it. Refer to the software help for more detailed information on operating the software. To open the help, launch NAS Navigator2 and navigate to *Help > NAS Navigator2 Help* from the menu bar.

NovaBACKUP

NovaBACKUP is a Windows utility that lets you back up data on your computer.

The NovaBACKUP installer is available from the d.buffalo website, accessible from <https://d.buffalo.jp/TS71210RH/>.

Once you have accessed the URL, select the region and model to go to your specific model's d.buffalo website.

Download the NovaBACKUP installer and install the utility onto your computer.

To download the installer, you will need the serial number of your TeraStation. The serial number is printed on the label on the back or the top of the unit.

Chapter 14 Appendix

Info and Error LEDs

If there is a corresponding corrective action described below for a code, try it first. If the code is still displayed after trying the corrective action, contact Buffalo technical support for assistance.

Errors

If a critical error occurs, the error LED will glow red. Confirm the current status from the Dashboard in Settings or by using NAS Navigator2. If NAS Navigator2 displays the error as an unknown error, check the Dashboard in Settings for the error details.

Code	Description	Corrective Action
E10	The TeraStation is running on the UPS battery due to a power outage.	Shut down the TeraStation safely and wait until the power outage ends. If certain settings are configured, the TeraStation may shut down automatically when the error is detected.
	If the setting to use the UPS connected to this TeraStation has been configured, the UPS cable may be disconnected.	Verify that the UPS cable or Ethernet cable is connected properly.
	If the setting to use the UPS connected to another TeraStation on the same network has been configured, the Ethernet cable of this TeraStation may be disconnected.	
E11	An error occurred with the fan's speed.	Check that no foreign objects or dust are clogging the fan. If any foreign objects or dust are found, use a pair of tweezers, an air duster, or other tools to remove them.
E12	The system temperature has exceeded the allowable safety value.	Move the TeraStation to a cool location. Do not place objects in the area around the TeraStation.
E14	The RAID array cannot be mounted.	If the message appears after initial bootup, make sure drives are inserted properly by referring to the "Re-Inserting Drives" section in chapter 12. For all other cases, run a drive check on the RAID array by referring to the "Checking Drives" section in chapter 5.
E16	The drive cannot be found.	Re-insert the drive by referring to the "Re-Inserting Drives" section in chapter 12.
E22	The drive cannot be mounted.	Format the drive by referring to the "Formatting Drives" section in chapter 5. After formatting, if the error still appears after rebooting, replace the drive by referring to the "Replacing a Defective Drive" section in chapter 12.

Code	Description	Corrective Action
E27	The failover backup TeraStation cannot be found.	Reconfigure the failover backup TeraStation for failover by referring to the “Configuring Failover” section in chapter 6.
E30	An error occurred, so the drive was removed from the RAID array.	Replace the drive by referring to the “Replacing a Defective Drive” section in chapter 12.
E32	Power supply error.	Make sure that the power cable is securely connected. If the error is still present, replace the failed power supply to a new OP-PU-10R2 unit.
E41	The NVRAM inside the TeraStation failed.	Contact Buffalo technical support for assistance.
E42	The migration process has been canceled because an error occurred.	Refer to the NAS migration guide for the detailed corrective actions.
E43	The SSD cache could not be deleted.	Try the SSD cache deletion process again. If the error is still present, forcibly delete the SSD cache.
E44	The SSD for caching was not found.	Make sure that the SSD card is securely inserted.
E45	An error occurred with the SSD for caching.	The SSD card failed. Replace the failed SSD card with a new SSD card.

Alerts

If a non-critical error occurs, the info LED will glow amber. Confirm the current status from the Dashboard in Settings or by using NAS Navigator2. If NAS Navigator2 displays the error as an unknown error, check the Dashboard in Settings for the error details.

You can click the “Clear” button to delete messages from the Dashboard.

Code	Description	Corrective Action
I10	The system temperature may have exceeded the allowable safety value.	Move the TeraStation to a cool location. Do not place objects in the area around the TeraStation.
I11	The drive has too many bad sectors.	Replace the drive by referring to the “Replacing a Defective Drive” section in chapter 12.
I12	The RAID array is in degraded mode.	Check if the E30 error is also displayed. If it is, refer to the corrective action for the E30 error.
I33	An error occurred in replication, or synchronization between the main and backup TeraStations failed during failover configuration.	From Settings, navigate to <i>Backup > Replication</i> and click <i>Resync</i> to execute resynchronization. If you configured the subfolders’ access restrictions to be inherited to the replication or failover destination, disable them or change the destination.
I44	Initialization from the USB initialization drive was initiated, but the drive in slot 1 was not detected.	Make sure that the drive in slot 1 is present and fully inserted into its slot.
I45	Initialization failed.	-

Code	Description	Corrective Action
I49	The main TeraStation in the failover configuration cannot be found.	Make sure that the main TeraStation is on, working, and connected to the network.
I54	The backup job failed.	Refer to the “Backup Logs for If Backup Fails” section in chapter 6 and try the respective corrective actions.
I55	Authentication during initialization of settings failed.	Settings can only be restored for the TeraStation whose settings were originally saved.
I64	Connecting to the cloud storage service failed.	Open Settings and check the status of the job that failed for the cloud service. Refer to the error log on the job list of the specific cloud storage service and check the cause of the error.
I66	Available free space has decreased to 1% or less.	Increase the free space.
I70	There is not enough space to save file access logs.	Delete file access logs to free up space.
I72	The target folder for saving logs has been changed to the system area.	Reconfigure the settings by referring to the “Changing Archive Rules for File Access Logs” section in chapter 11.
I75	Data migration has finished but some files and folders could not be migrated.	Refer to the NAS migration guide for the detailed corrective actions.
I77	The SSD cache deletion process has been canceled.	Try the SSD cache deletion process again.

Information Events

After you change any settings, the info LED will glow amber. Confirm the current status from the Dashboard in Settings or by using NAS Navigator2. If NAS Navigator2 displays the status as an unknown error, check the Dashboard in Settings for the status details.

You can click the “Clear” button to delete messages from the Dashboard.

Code	Description	Corrective Action
I01	Checking the system area.	-
I13	Formatting the RAID array.	-
I14	Checking the RAID array.	-
I15	Scanning data on the RAID array. Note: Transfer speeds are slower during the examination process.	-
I16	Creating the RAID array.	-
I17	Resynchronizing the RAID array. Note: Transfer speeds are slower during resynchronization.	-
I18	Rebuilding the RAID array. Note: Transfer speeds are slower during the rebuilding process.	-
I19	Rewriting drives in the TeraStation with 0s.	-
I20	Formatting the drive.	-
I21	Checking the drive.	-
I22	Rewriting drives in the TeraStation with 0s.	-

Code	Description	Corrective Action
I23	The initialization process has been started by using the reset button and settings are being initialized.	-
I25	Updating the TeraStation firmware.	Do not turn off the TeraStation's power.
I26	The initialization process has been started by using Settings and all settings are being initialized.	-
I27	Checking the USB drive.	-
I28	Formatting the USB drive.	-
I31	Appears before the function button is pressed in order to use a newly-inserted drive.	Press the function button. If the RAID array enters degraded mode, the array will be rebuilt using the new drive. Otherwise, the new drive will be set as a hot spare. To use a drive as normal instead of a hot spare drive, refer to the " Drive Replacement for a Hot Spare " section in chapter 12.
I32	Appears after replacing the drive when the RAID array needs to be rebuilt in Settings or formatting is necessary.	From Settings, either recover the RAID array or format the drive.
I37	The initialization process has been started by using the USB initialization drive and settings are being initialized.	-
I38	Settings initialization is finished.	-
I40	Starting settings initialization. All data on the drives may be deleted.	-
I41	Press the function button to start the settings initialization process.	-
I42	Preparing to start the settings initialization process.	-
I43	The TeraStation was started from the USB initialization drive, but the settings cannot be initialized from this USB initialization drive.	-
I46	Data migration or conversion (RAID migration) is in progress.	Do not turn off the TeraStation's power.
I47	Data migration or conversion (RAID migration) is in progress.	Do not turn off the TeraStation's power.
I48	This TeraStation is ready to become the failover backup device for the main TeraStation.	Press and hold down the function button of the failover backup TeraStation until it stops beeping to accept failover backup status.
I50	Failover maintenance is in progress.	Do not turn off the TeraStation's power.
I51	Initializing the failover configuration.	Do not turn off the TeraStation's power.
I52	A new firmware version has been released.	Update the firmware by referring to the " Updating the Firmware " section in chapter 11.

Code	Description	Corrective Action
I61	The unit is in drive setup mode.	Recover from drive setup mode by referring to the “Power LED Keeps Blinking” section in chapter 12.
I65	Available free space has decreased past the configured threshold percentage.	Increase the free space or change the threshold to a lower value.
I71	There is not enough free space so older logs were removed.	Delete file access logs to free up space.
I73	Data or settings migration is in progress.	-
I74	Data or settings migration has finished.	Refer to the NAS migration guide for the detailed corrective actions.
I76	Deleting the SSD cache.	Do not turn off the TeraStation’s power.

Default Settings

Setting	Default	
Administrator’s Name	admin	
Password	password	
Shared Folders	“share” for both Windows and macOS computers. Note: The recycle bin is enabled by default.	
IP Address	The TeraStation will get its IP address automatically from a DHCP server on the network. If no DHCP server is available, then an IP address will be assigned as follows: IP Address: 169.254.xxx.xxx (“xxx” is a number randomly assigned when booting the TeraStation.) Subnet Mask: 255.255.0.0	
Registered Groups	“hdusers”, “admin”, “guest”, and “powerusers” You cannot edit or delete these default groups.	
Microsoft Network Group Settings	WORKGROUP	
MTU Size	1,500 bytes	
SMB	Enabled	
	Protocol Selection	Auto
	SMB Signing	Default
	Recycle Bin Permissions	All users
	macOS Temp Files	Keep when original file is deleted
	Network Credentials	Log in as guest
	SMB Multichannel	Disabled
Enhanced Compatibility with macOS Clients	Disabled	
AFP	Disabled	
FTP	Disabled	
SFTP	Disabled	
WebAccess	Disabled	
NFS	Disabled	
rsync	Disabled	
RAID Scanning	Disabled	
iSCSI	Disabled	

Setting	Default	
Amazon S3-Compatible Storage	Disabled	
Box Storage Sync	Disabled	
Dropbox Sync	Disabled	
Microsoft Azure Storage Sync	Disabled	
Microsoft OneDrive Sync	Disabled	
SNMP	Disabled	
Replication	Disabled	
Time Machine	Disabled	
Name/Time/Language	NTP	Enabled
Email Notification	Disabled	
Restore/Erase	Admin Username and Password	Restore factory default settings
RAID Mode	RAID 6	

Specifications

Check the [Buffalo website](#) for the latest product information and specifications.

Technical Specifications	
LAN Interface	
Standards Compliance	IEEE 802.3an (10GBASE-T), IEEE 802.3ab (1000BASE-T)
Data Transfer Rates	10 Gbps, 1000 Mbps (auto sensing)
Number of Ports	4
Connector Type	RJ-45 8-pin (auto MDI-X)
Supported Protocols	TCP/IP
Network File Services	SMB/CIFS, AFP, FTP/SFTP, NFS, HTTP/HTTPS
MTU Sizes	1,500–9,216 bytes
USB Interface	
Standards Compliance	USB 3.2 Gen 1/USB 2.0
Data Transfer Rates	USB 3.2 Gen 1: max. 5 Gbps USB 2.0: max. 480 Mbps
Number of Ports	2 × USB 3.2 Gen 1, 2 × USB 2.0
Connector Type	Type A
Internal Drive	
Number of Drive Bays	12
Drive Interface	SATA 6 Gbps
Supported RAID	0, 1, 5, 6, 10, JBOD (individual drives)
Replacement Drive	Buffalo OP-HDH2U series drive Note: The replacement drive should be the same capacity or larger as the original drive. The drives listed above are available from the Buffalo website .

Product Specifications	
Power Supply	AC 100–240 V, 7.0–3.5 A, 50/60 Hz
Dimensions (W × H × D, excluding protruding parts)	481 × 88 × 736.9 mm (18.9 × 3.5 × 29.0 in.)

Product Specifications	
Weight	Fully-populated model: 24.3 kg (53.6 lbs) Partially-populated model: 18.1 kg (39.9 lbs)
Maximum Power Consumption	500 W
Operating Environment	Temperature: 0–40°C (32–104°F) Humidity: 10–85% non-condensing
Compatible Devices	Windows PCs, Apple silicon- and Intel-based Mac computers with wired or wireless Ethernet connection.
Supported OS	Windows 11, 10 Windows Server 2022, 2019, 2016 macOS 13.0, 12.0, 11.1, 10.15