



UltraLine® 7400 Series

Electric Strikes for Adams Rite Deadlatches, Cylindrical Locks

Designed for use with Adams Rite deadlatches or cylindrical locksets with 1/2" [12.7 mm] to 5/8" [15.9 mm] latchbolt projection. For use in aluminum, hollow metal, or wood applications.

Open electrically under 25 lbs [11.3 kg] of preload. Preload is pressure exerted on doors by air conditioning systems, warping or misaligned hardware which can disable common electric strikes.

Function

This non-handed strike features an ultra-compact design and adjustable stainless steel keepers with over 1,500 lbs [680.4 kg] of holding force in fail secure mode. The strike releases electrically with up to 25 lbs of door preload. Single solenoid operates on 12/16/24 VDC power.

Remote electrical control of narrow stile aluminum doors equipped with an Adams Rite 4500, 4700 (discontinued), or 4900 Deadlatch or cylindrical lockset with 1/2" [12.7 mm] to 5/8" [15.9 mm] latchbolt projection. Electrical actuation unlocks the keeper, releasing the latchbolt so the door may be opened without operating the latch itself.

Certifications

UL 1034 Burglary-Resistant Listed and Suitable for Outdoor Use

UL 294
ULC-S319

ANSI/BHMA A156.18

ANSI/BHMA A156.31
Electric Strikes and Frame Mounted Actuators, Grade 1



7400

7401



7410

7411

7430



7431

7440

Features

Case

1-13/32" x 3-3/8" x 1-1/16" deep
[35.7 mm x 85.7 mm x 27 mm deep]

Strike Lip

Basic 7400 strike has lip of proper length for 1-3/4" [44.5 mm] thick door that closes flush with jamb edge. Where door thickness or jamb shape differs from this standard relationship, lip extension kits are available.

Lip extension kits not available on 7401, 7431

Strike Opening

5/8" adjustable x 1-7/16" x 1/2" deep [15.9 mm adjustable x 36.5 mm x 12.7 mm deep]. Bolt retaining keeper is stainless steel. Strike accepts bolt of Adams Rite 4500, 4700 (discontinued), or 4900 Deadlatch or cylindrical locksets.

Latchbolt Projection

1/2" to 5/8" [12.7 mm to 15.9 mm]

Preload

7400 Series Electric Strikes open electrically under 25 lbs [11.3 kg] of preload. Preload is pressure exerted on doors by air conditioning systems, warping or misaligned hardware which can disable common electric strikes.

Using jaw inserts of various sizes, the Ultraline 7400 Series electric strikes are adjustable to compensate for door and frame related preload and security problems.

Faceplate

Available in a variety of architectural finishes. Faceplates are also available sold separately.

7400	1-1/4" x 4-7/8" [31.8 mm x 123.8 mm]	Flat with radius corners
7401	1-1/4" x 4-7/8" [31.8 mm x 123.8 mm]	Radiused to match nose on inactive leaf in a pair of narrow stile doors.
7410	1-7/16" x 7-15/16" [36.5 mm x 201.6 mm]	Flat with radius corners
7411	1-7/16" x 10-1/4" [36.5 mm x 260.4 mm]	Flat with radius corners
7430	1-1/4" x 6-7/8" [31.8 mm x 174.6 mm]	Flat with radius corners
7431	1-1/4" x 6-7/8" [31.8 mm x 174.6 mm]	Radiused to match nose on inactive leaf in a pair of narrow stile doors
7440	1-1/4" x 4-7/8" [31.8 mm x 123.8 mm]	Flat with square corners

7430/7431: Large 6-7/8" faceplate is designed to cover strike opening when converting from an MS® pivoted-bolt deadlock to deadlatch.

Standard Package

Individually boxed with mounting screws, mounting tabs, adhesive shims to accommodate jamb or stile extrusion thickness greater or less than nominal 1/8" [3.2 mm], an adjustable keeper shim pack and two plug-in voltage adapters for 12/24 VDC.

Shipping Weight

2 lbs [0.91 kg].

Electrical

Voltage

Field selectable to match power source of 12/24 VDC. VA7400-16VDC voltage adapter required when using 16 VDC power, available separately. Equipped with a quick connect plug-in type connector.

Current Draw

.44 A at 12 VDC

.46 A at 16 VDC*

.23 A at 24 VDC

*Requires 16 DC adapter (P/N VA7400-16VDC)

Fail Safe | Fail Secure

Field selectable fail safe/fail secure

Options

- Available with two Form 'C' monitoring switches to indicate when the latchbolt is engaged in the strike jaws and a locked/unlocked solenoid status.
- Lip extension kits for various dimensions of door centerline to jamb edge; for flat faceplates only.
- **Modular Packaging**
Match one strike body kit with one faceplate kit to make a complete electric strike. Faceplate kits contain all hardware to mount electric strike. Please contact factory or sales representative for details.
- **ELX-ElectroLynx® Adapter**
Connects Adams Rite electrified products to ElectroLynx system.
- **16 VDC Adapter**
VA7400-16VDC required when using 16 VDC Power
- **Wood Door Cover**
WDC7400 for use when mounting the 7400 Series Electric Strike on the inactive leaf of a pair of doors. The cover simplifies the mortise prep.

Related Products

7400/7401, 7410/7411, 7430/7431, 7440

When purchasing this product, please consider the following related products, available separately:

DEADLATCHES	EXIT DEVICES	ACCESSORIES	POWER
4510, 4530, 4900, 4920AN Series Deadlatches	8300, 8400 Mortise Exit Device	Modular Kits, Lip Extension Kits, WDC7400-Wood Door Cover, Faceplate Kits	4603 Rectifier, 4605/4606 Transformer, Piezo Horn audible indicator, ElectroLynx connector, VA7400 Voltage Adapter

All measurements are approximate and are provided for informational purposes only. Refer to the product Installation Instructions.

7400/7401 Dimensions

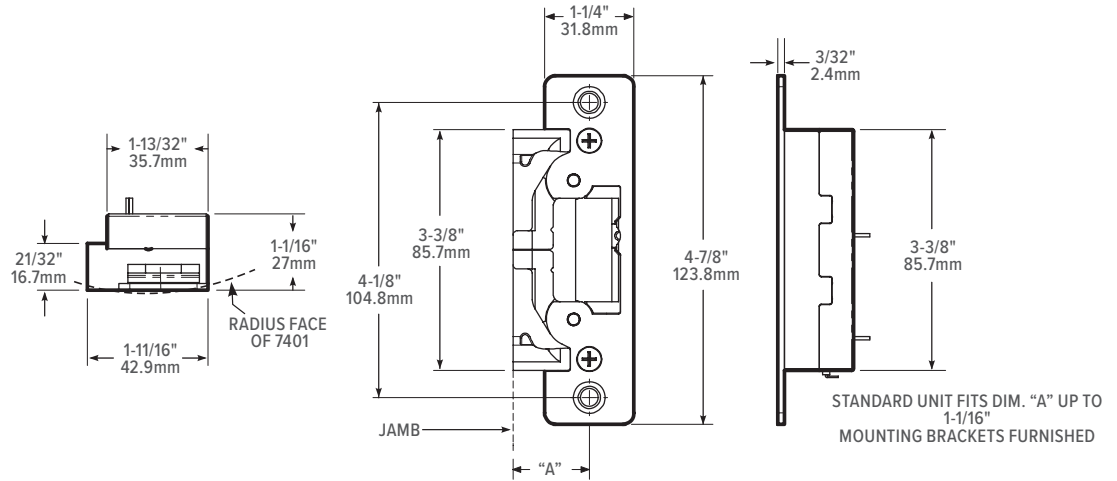

Jamb Preparation

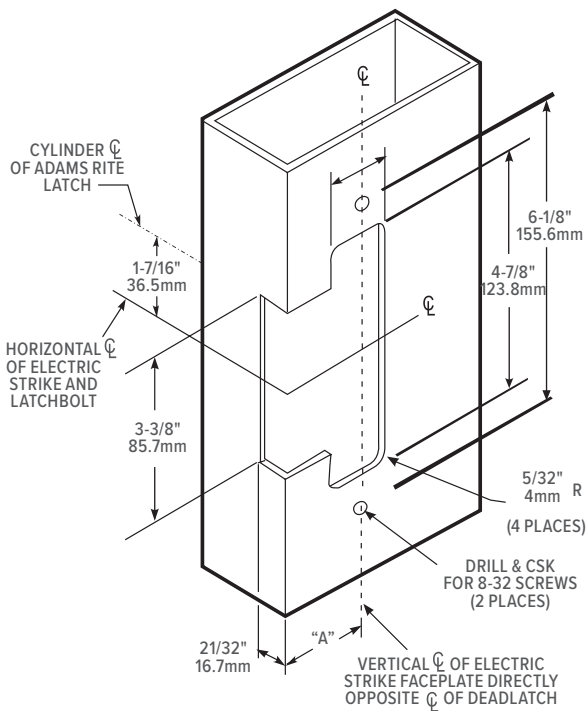

Installation

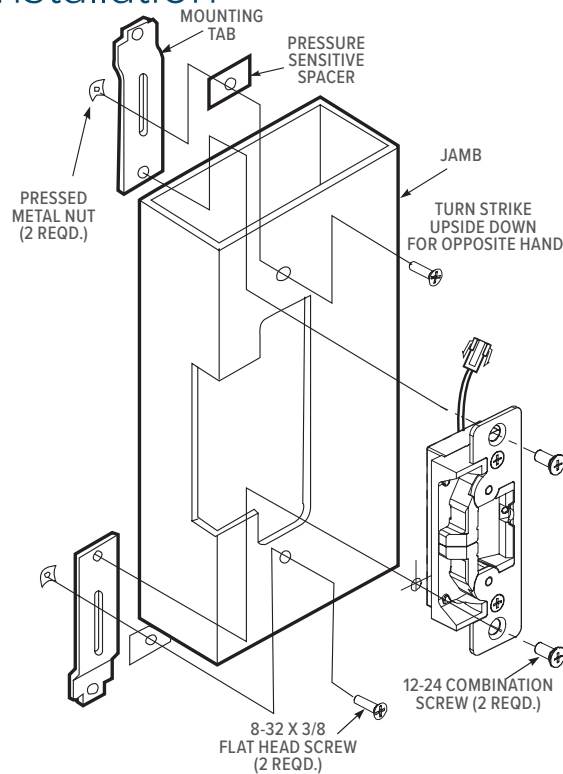

How to Order

7400/7401 Electric Strikes: Specify quantity and the following information. Order related products separately.

MODEL	FACEPLATE SHAPE	FEATURES*	FINISH		
740	0	M	628		628
	0 Flat	- None	7400 ONLY		7401 ONLY
	1 Radius	M Monitored	313 Dark Bronze Anodized	626 Satin Chrome	119 To match 335 Black Anodized
		A Modular Pack – Body Kit	335 Black Anodized	628 Clear Anodized	121 To match 313 Dark Bronze Anodized
			605 Bright Brass	630 Satin Stainless	130 To match 628 Clear Anodized
			606 Satin Brass		

*Fail-secure can be field converted to fail-safe or vice-versa.



US adamsrite.com | 800.626.7590 | customerservice.adamsrite@assaabloy.com

Canada assaabloydss.ca | 800.461.3007 | sales.dss.ca@assaabloy.com

Updated: July 31, 2025

All measurements are approximate and are provided for informational purposes only. Refer to the product Installation Instructions.

7410/7411 Dimensions

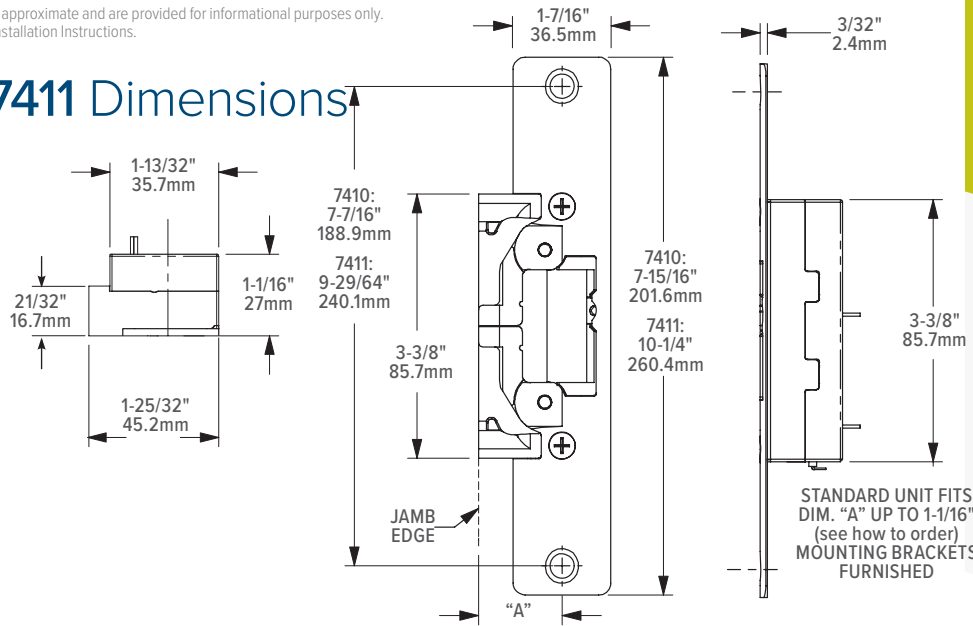

Jamb Preparation

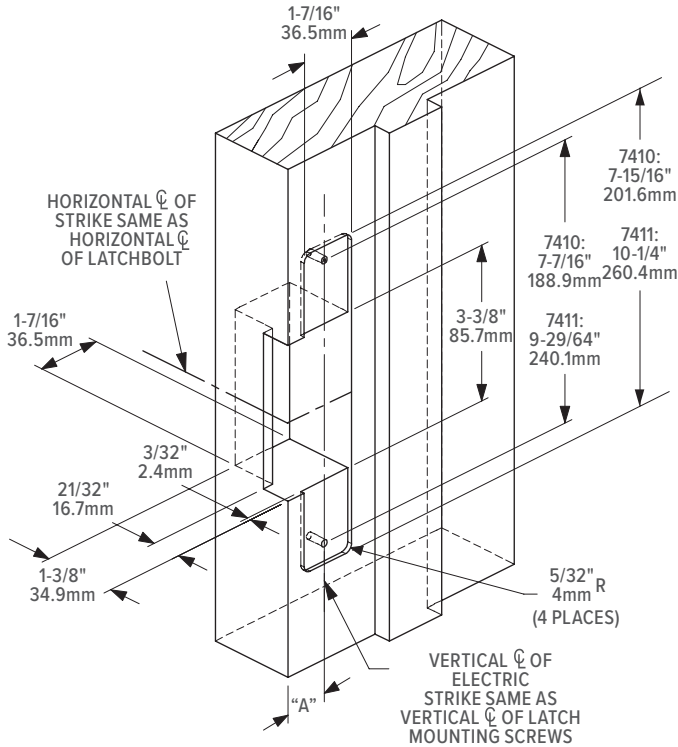

Installation in Wood

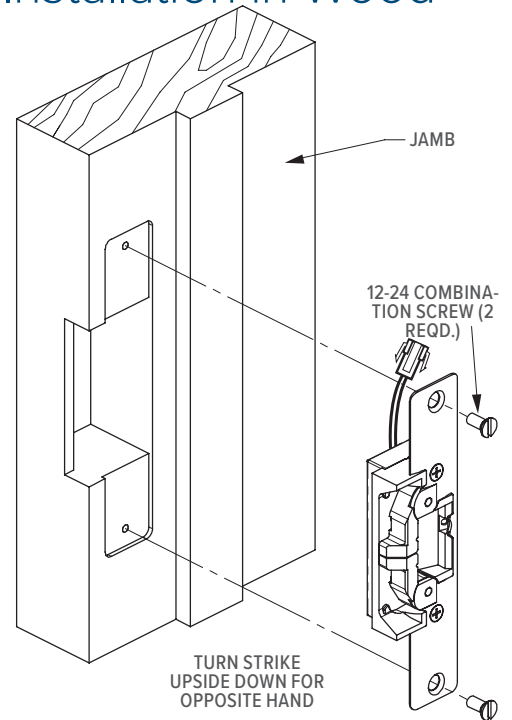

How to Order

7410/7411 Electric Strikes: Specify quantity and the following information. Order related products separately.

MODEL	FACEPLATE LENGTH	FEATURES*	FINISH
741	0	-	628
	0 7-15/16"	- None	313 Dark Bronze Anodized
	1 10-1/4"	M Monitored	335 Black Anodized
			628 Clear Anodized
			630 Satin Stainless

*Fail-secure can be field converted to fail-safe or vice-versa.

All measurements are approximate and are provided for informational purposes only. Refer to the product Installation Instructions.

7430/7431 Dimensions

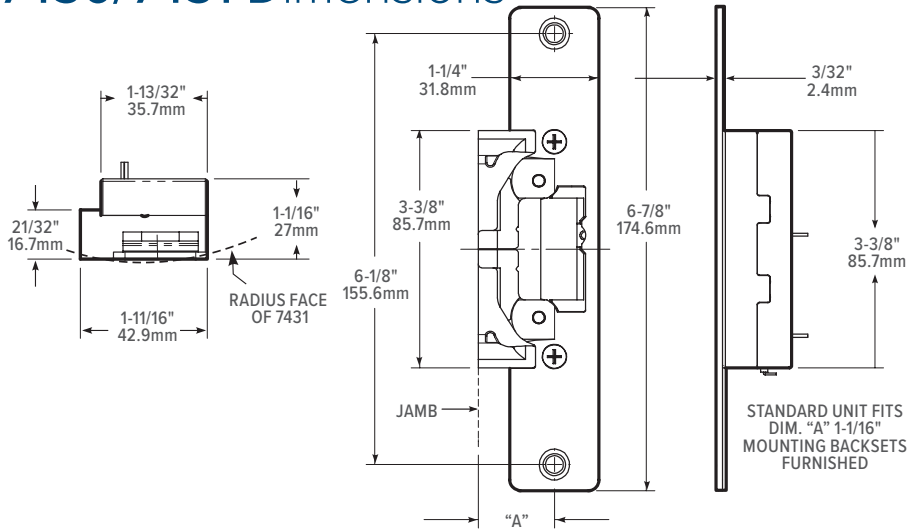

Jamb Preparation

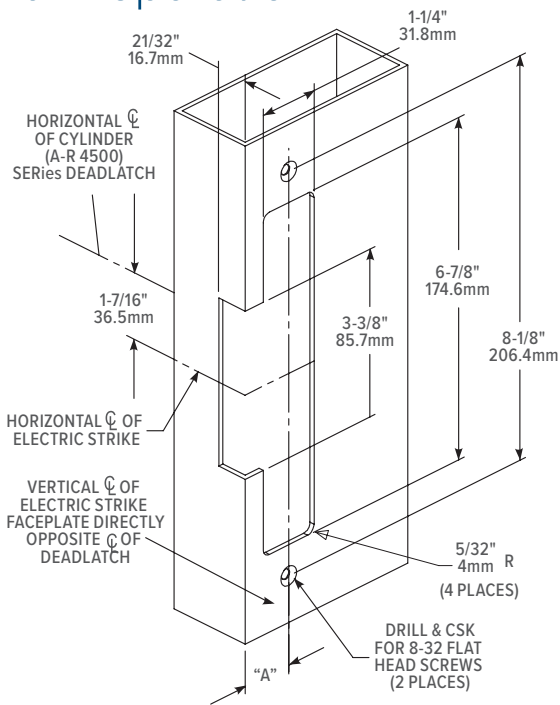

Installation

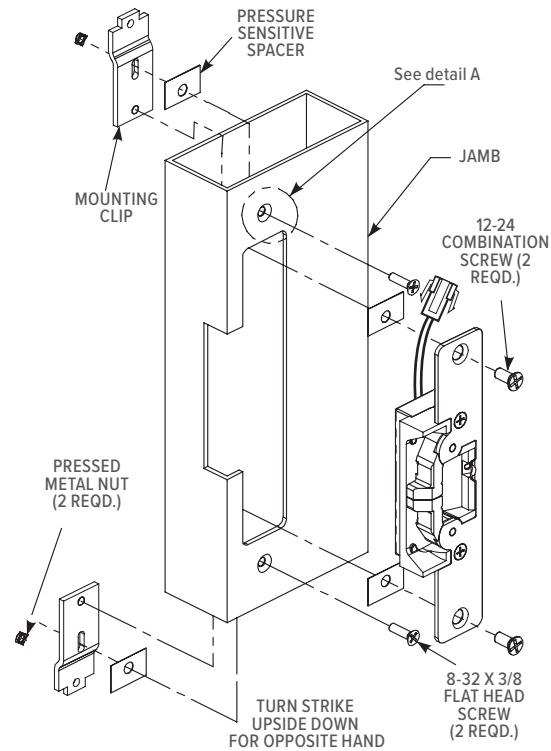

How to Order

7430/7431 Electric Strikes: Specify quantity and the following information. Order related products separately.

MODEL	FACEPLATE SHAPE	FEATURES*	FINISH	
743	0	M	628	
	0 Flat	- None	7430 ONLY	7431 ONLY
	1 Radius	M Monitored	313 Dark Bronze Anodized	119 To match 313 Dark Bronze Anodized
			335 Black Anodized	121 To match 335 Black Anodized
			628 Clear Anodized	119 To match 628 Clear Anodized

*Fail-secure can be field converted to fail-safe or vice-versa.

7440 Dimensions

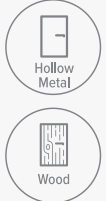
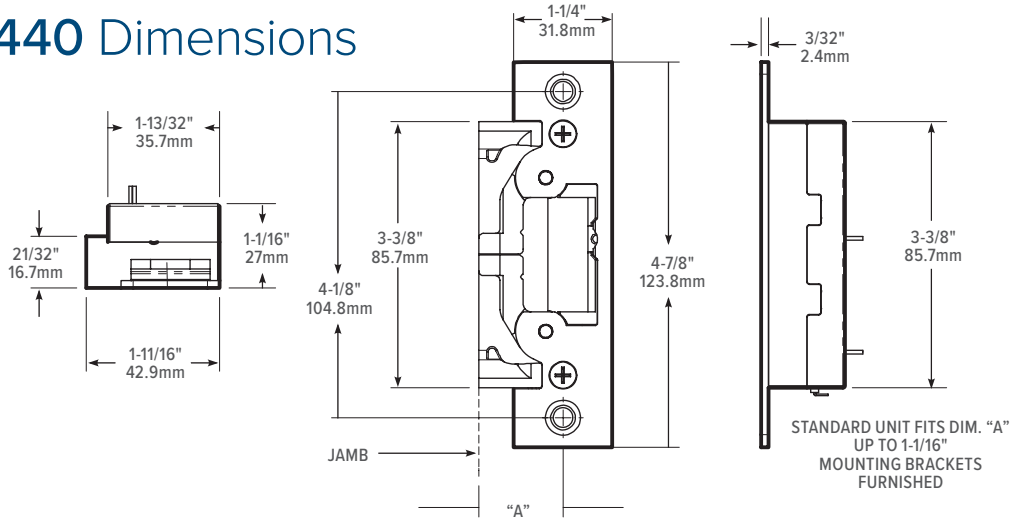

Jamb Preparation in Steel

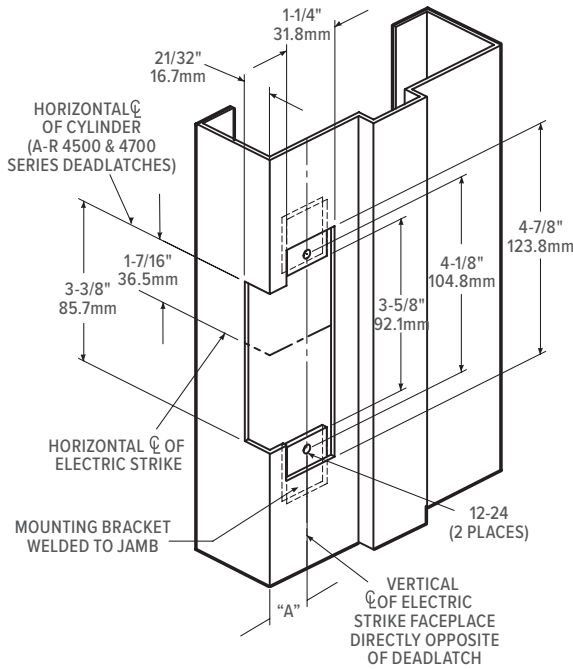

Installation in Steel

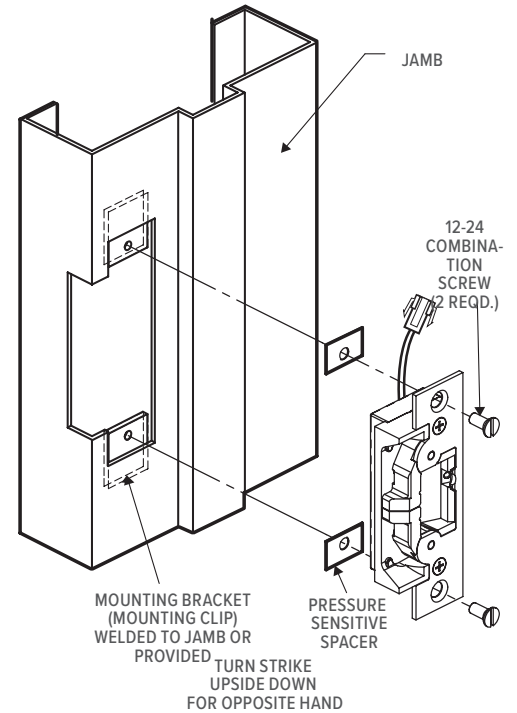

Installation in wood requires WDC7400. See Options & Accessories for more information.

How to Order

7440 Electric Strike: Specify quantity and the following information. Order related products separately.

MODEL	FEATURES*	FINISH	
7440	M	628	
	- None	313 Dark Bronze Anodized	628 Clear Anodized
	M Monitored	335 Black Anodized	629 Bright Stainless
		605 Bright Brass	630 Satin Stainless
		606 Satin Brass	

*Fail-secure can be field converted to fail-safe or vice-versa.