

# BOX Single Bay Cabinets INSTALLATION INSTRUCTIONS

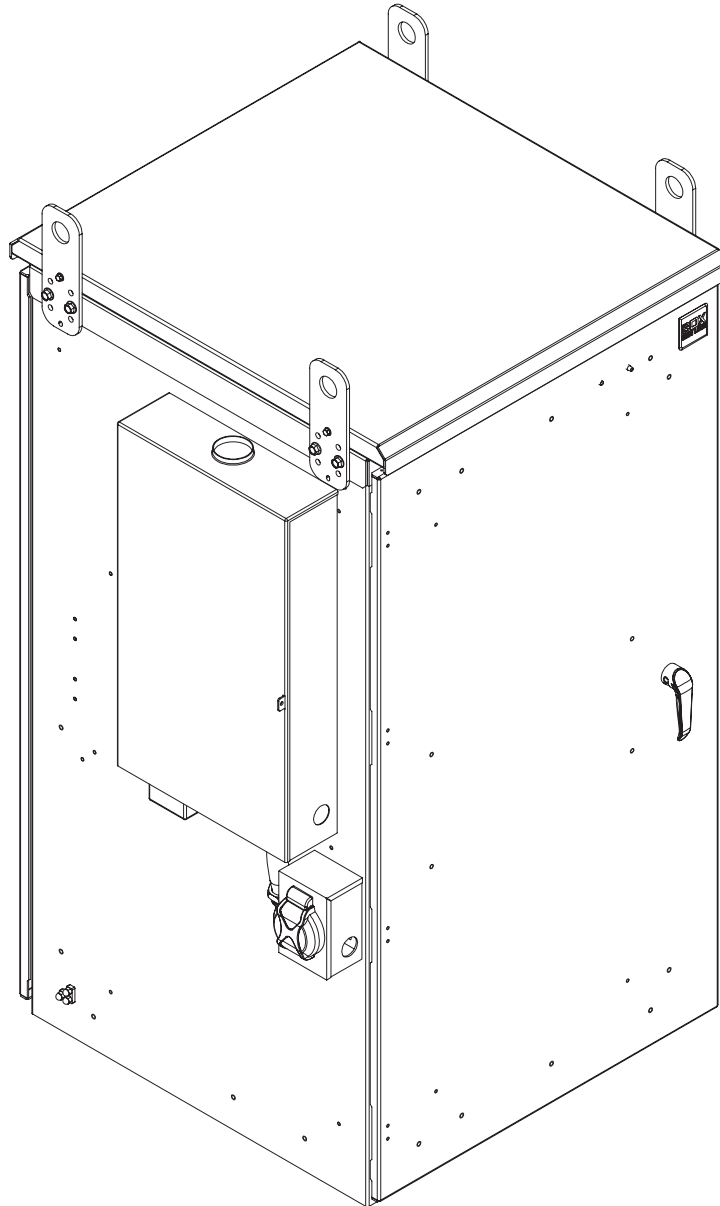

(Shown with optional accessories)

GreatCabinets.com

**1.814.734.7303**

# TABLE OF CONTENTS

- Preface ..... 3
- Configurations ..... 4
- Installation Warnings ..... 5
- Removing from Pallet ..... 5
- What's Included ..... 6
- Overview**
  - Overall Dimensions ..... 6
  - Clearance Dimensions ..... 7
  - External View ..... 8
  - Internal View ..... 8
- Prior to Anchoring or Mounting The Cabinet**
  - Lift Eyes ..... 10
  - Concrete Pad Recommendations ..... 11
- Anchor Methods**
  - Option 1: Cabinet (with a riser or plinth) and a Wet Concrete Template ..... 10
  - Option 2: Cabinet (with a riser or plinth) Directly to Concrete ..... 14
  - Option 3: Cabinet (with out a riser or plinth) Directly to Concrete ..... 17
- Door & Door Handle ..... 19
- Gland Plate ..... 21
- Mounting Rail Adjustment ..... 22
- 19" to 23" EIA Mounting Rail Orientation ..... 23
- Grounding ..... 24
- Terminal Block & Receptacles ..... 26
- Load Center & Generator Plug ..... 27
- Configuration Options**
  - HVAC Units ..... 28
  - 16" Battery Plinth ..... 29
- Optional Accessories**
  - Laptop Tray ..... 30
  - Fiber Spools ..... 32
  - Cable Management Fingers ..... 33
  - ¼ Turn "D" Rings ..... 34
  - Front-to-Rear Cable Trough ..... 35
  - Interior Light Kit ..... 36

## PREFACE

This manual is provided to prevent service personnel from committing an act that results in the risk of fire, electric shock, or injury to persons. Only trained service personnel should receive, unpack, and assemble. In addition, only trained service personnel should install equipment in cabinets.

### SAFETY SYMBOLS USED IN THIS MANUAL

This manual provides general safety guidelines to be observed during installation, operation, and maintenance of the cabinet.



**WARNING:** Failure to follow directions in the warning could result in injury to persons or loss of life.



**CAUTION:** Failure to follow directions in the caution could result in damage to equipment or storage data.



**WARNING:** Improper handling and use of the cabinet could result in equipment damage, serious injury, or possible death.

Only trained service personnel should be used to remove the cabinet from the shipping pallet. Also, be sure you have a sufficient number of service personnel. Do not attempt to move cabinets by yourself.

Be sure to read and follow all individual manufacturer equipment manuals for safety and installation instructions.

Proper spacing is required when installing electrical equipment to avoid electrical shock. Maintain minimum spacing between the accessories and components and the computer cabinet assembly for safe operation of the equipment when installed in accordance with the National Electric Code ANSI/NFPA 70-2023.

## SERVICE

Cabinets should be repaired by personnel trained by Great Lakes, or returned to Great Lakes for repair or replacement.

**For repair, troubleshooting, or questions related to information found in this manual, contact Great Lakes Technical Support at 814.734.7303 or at [TechSupport@GreatCabinets.com](mailto:TechSupport@GreatCabinets.com)**

# BOX SINGLE BAY SERIES & CONFIGURATIONS

This user manual applies to the following sizes of BOX Single Bay Cabinets. Note, the series number is intended to represent the various BOX sizes available; it is not a complete part number. For a complete part number, see BOX Single Bay Configured Cabinet. In some instances, a purchased BOX Single Bay Cabinet part number may begin with 'DC'; this manual applies to DC cabinets as well.

## BOX SINGLE BAY SERIES

Part No.	RMU	H"	W"	D"
BXSBxx-16U32	16	34"	30"	32"
BXSBxx-16U36	16	34"	30"	36"
BXSBxx-16U42	16	34"	30"	42"
BXSBxx-24U32	24	48"	30"	32"
BXSBxx-24U36	24	48"	30"	36"
BXSBxx-24U42	24	48"	30"	42"
BXSBxx-30U32	30	58.5"	30"	32"
BXSBxx-30U36	30	58.5"	30"	36"
BXSBxx-30U42	30	58.5"	30"	42"
BXSBxx-42U32	42	79.5"	30"	32"
BXSBxx-42U36	42	79.5"	30"	36"
BXSBxx-42U42	42	79.5"	30"	42"

## BOX SINGLE BAY CONFIGURED CABINET

Using the attribute chart below, select an option from each column to designate a standard BOX Single Bay.

Example: BXSB04-24U32-GY-12-AC020-115 (Type 4, 24U, 32"D, Gray, 12" Riser, AC Unit - 2000 BTU, 115VAC)

Rating	RMU	Depth	Color	Riser/Plinth	HVAC
BXSBxx-	xxU	xx-	xx-	xx-	xxxxx-xxx
<b>3R</b> (Type 3R)	<b>16</b>	<b>32</b>	<b>GY</b> (Gray)	<b>00</b> (none)	<b>00000-000</b> (none)
<b>04</b> (Type 4)	<b>24</b>	<b>36</b>		<b>04</b> (4" Riser)	<b>AC unit and heat exchanger options listed on web</b>
	<b>30</b>	<b>42</b>		<b>12</b> (12" Riser)	
	<b>42</b>			<b>16</b> (16" Battery Plinth)	

## NEMA RATINGS & UL

- BXSB3R indicates NEMA 250 Type 1, 2, 3R Rating; lap construction; UL LISTED PER UL508A AND CSA CERTIFIED PER CSA C22.2 No. 14
- BXSB04 indicates NEMA 250 Type 1, 2, 3R, 4, 5, 12, 12K Rating; seams fully welded; UL LISTED PER UL508A AND CSA CERTIFIED PER CSA C22.2 No. 14
- Cabinet is constructed of .125" thick aluminum
- Durable texture powder coat with UV rating; RAL 7035 Gray is standard

**NOTE: All measurements used this manual are in inches unless otherwise noted.**

# INSTALLATION WARNINGS

## Receiving, Unpacking, and Removing the cabinet from the shipping pallet

Unpack the cabinet by carefully removing the corrugated carton and corners. Avoid damaging the cabinet when removing packaging.



**WARNING:** Only trained service personnel should be used to remove the cabinet from the pallet. Be sure you have a sufficient number of service personnel. Do not attempt to move cabinets alone.



**WARNING:** Be careful when moving cabinets before installation. Sudden stops and starts, excessive force, obstructed routes, and uneven floor surfaces may cause the cabinet to topple over.

## LOADING EQUIPMENT



**WARNING:** To maintain a uniform distribution of the mechanical load, load the heaviest equipment first, at the bottom of the cabinet and load the lighter units at the top.

## WEIGHT CAPACITY

- 1000 lb. Maximum load when using all four lift eyes
- 1500 lb. Maximum rack mount load after cabinet is positioned and fastened to concrete pad

## REMOVING FROM PALLET

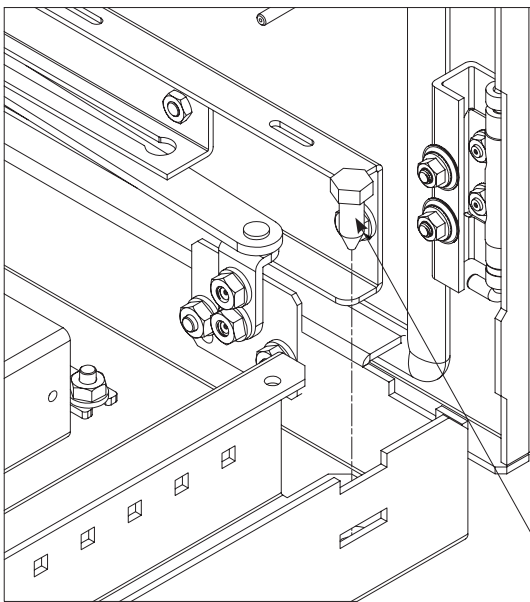

DETAIL A

Remove all (4)  
3/8" (9/16" socket) lag  
bolts in corners to free  
cabinet from pallet.

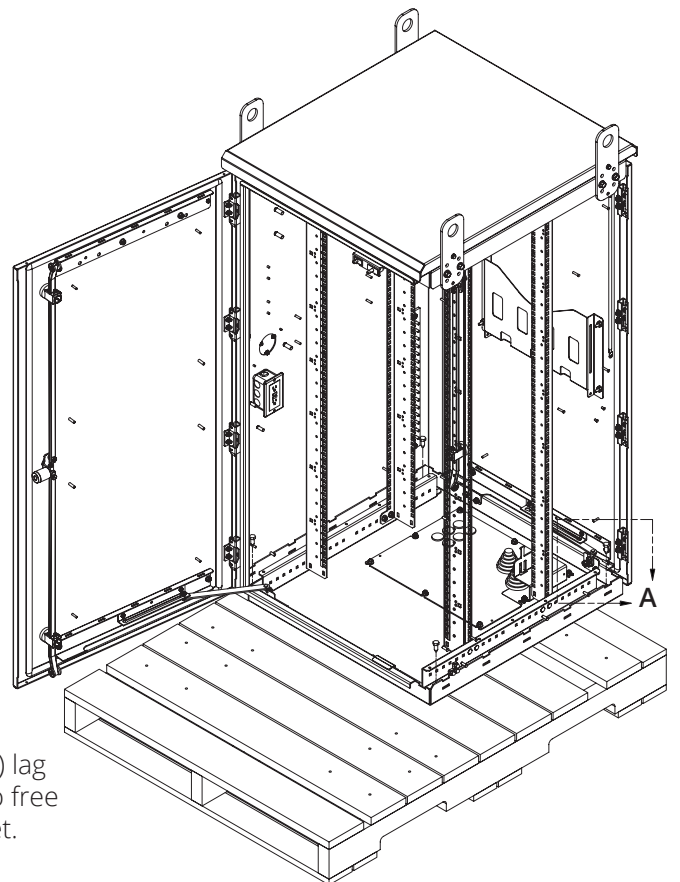

## WHAT'S INCLUDED

- BOX: Welded frame with two pairs of 3/8" sq. (M6) mounting rails with 19/23" EIA; rails set at 19" unless specified at time of order
- Solar shield; attached to the cabinet with four lift eyes
- Front and rear door with 3-pt latch swing handle with hasp; wind-stop on all doors
- 8.5" x 11" Document holder on rear door
- 15-Amp GFCI Duplex Receptacle (wired if optional load center is installed)
- Ground bar: Tinned copper, 16 position, 1/4" thick, 1/4" -20 threads at 5/8" spacing
- Terminal blocks, (2) 12 position mounted on panel
- Package of rack mount hardware
- The BOX Configured part number will determine if a riser/plinth or HVAC unit is included

## OVERVIEW

### OVERALL DIMENSIONS

Select a location for the cabinet that will allow for easy access of the cabinet and full swing capabilities of the doors. Overall dimensions and clearance dimensions for standard cabinets are shown below.

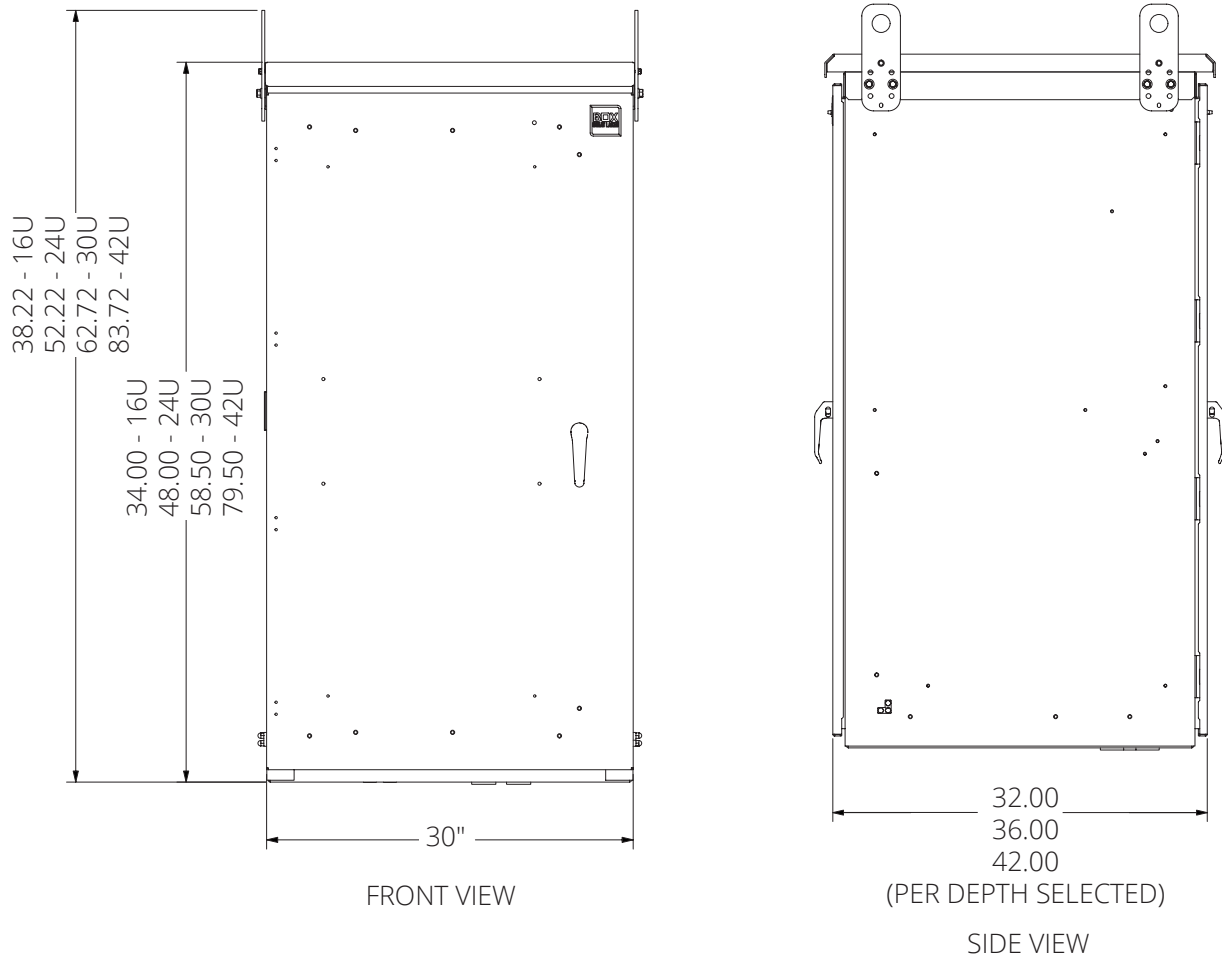

# CLEARANCE DIMENSIONS

Top section view of largest HVAC option with load center shown for reference.

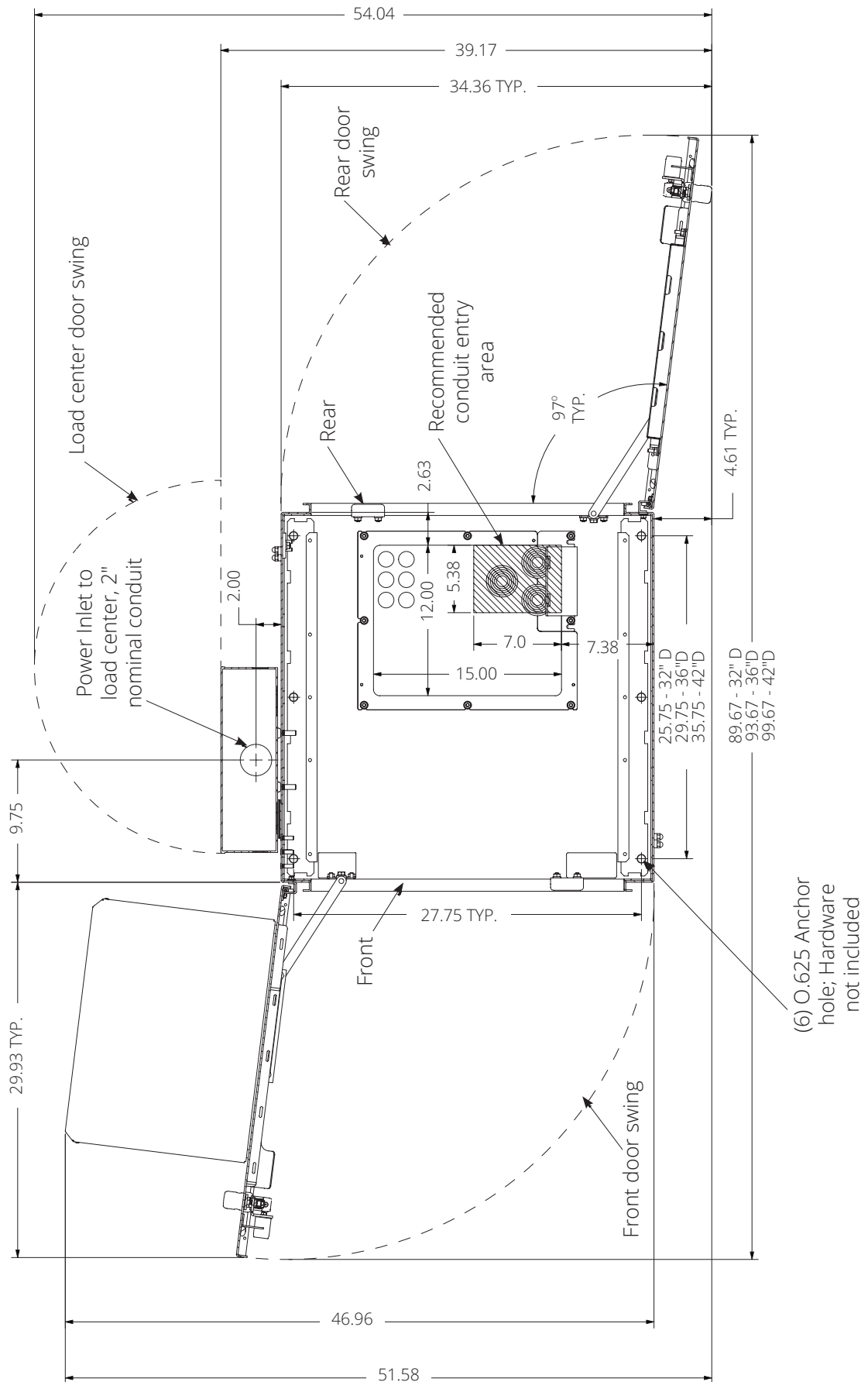

# OVERVIEW

## EXTERNAL VIEW

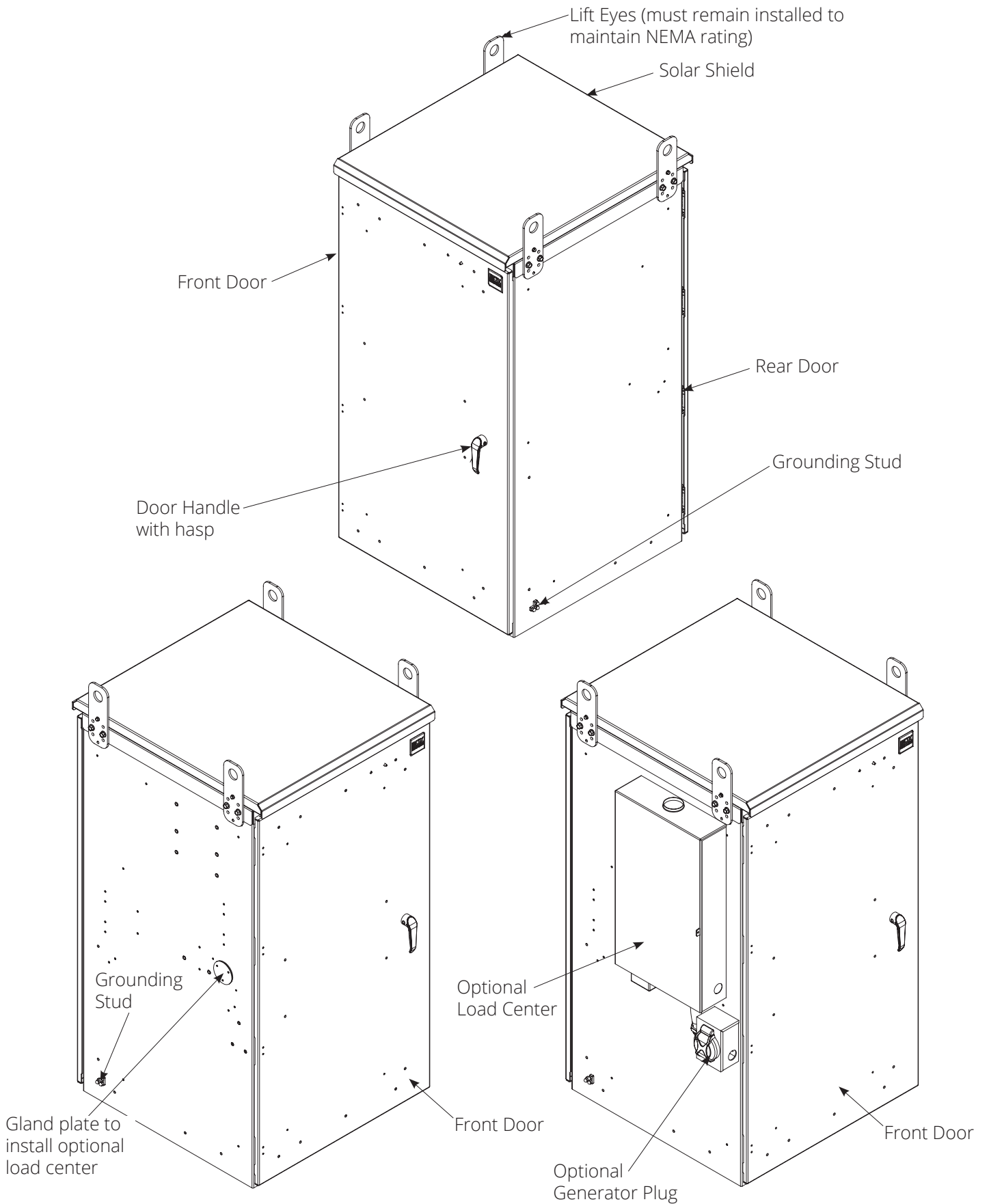

# OVERVIEW

## INTERNAL VIEW

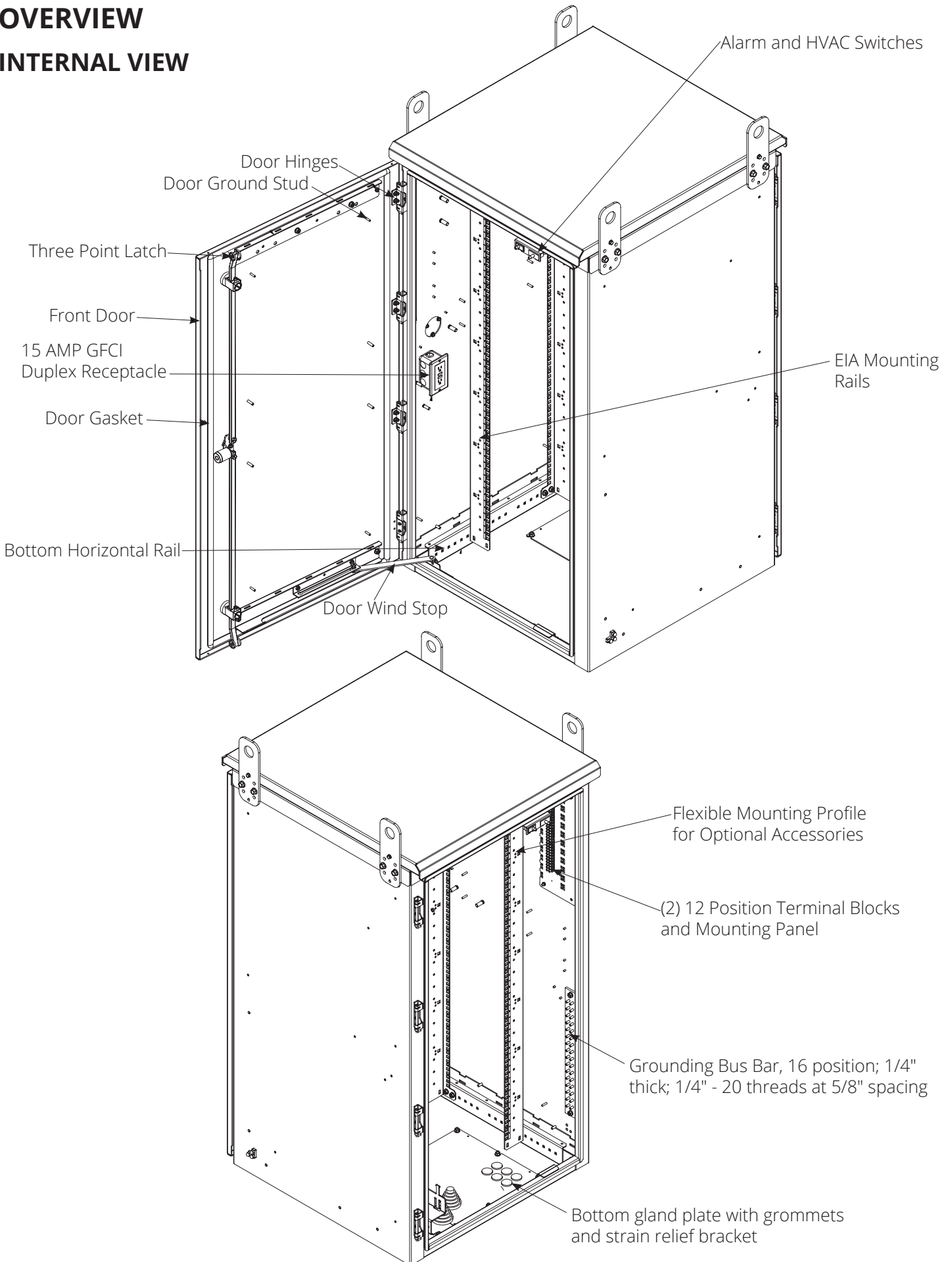

# PRIOR TO ANCHORING THE CABINET

## LIFT EYES

The **BOX** cabinet ships with four lift eyes installed on the top corners of the cabinet. Lift eyes are installed at the factory facing upwards.

### To reverse lift eyes:

1. Remove (1) 1/4" bolt (3/8" socket) and (2) 3/8" bolts (9/16" socket).
2. Rotate lift eye 180° (Ø1.50" hole will be on bottom for "downward" position) and reinstall bolts.

### DETAIL B

3. Repeat for remaining three lift eyes.
4. Steps 1-3 can be followed again to return lift eyes to upwards position, if desired

**LIFT EYE CAPACITY:** 1000 lb. Maximum load when using all four lift eyes

**ALL FOUR LIFT EYES MUST BE USED TO LIFT THE CABINET. LIFT EYES MUST REMAIN INSTALLED FOR CABINET TO MAINTAIN ITS NEMA RATING AND TO SECURE SOLAR SHIELD.**

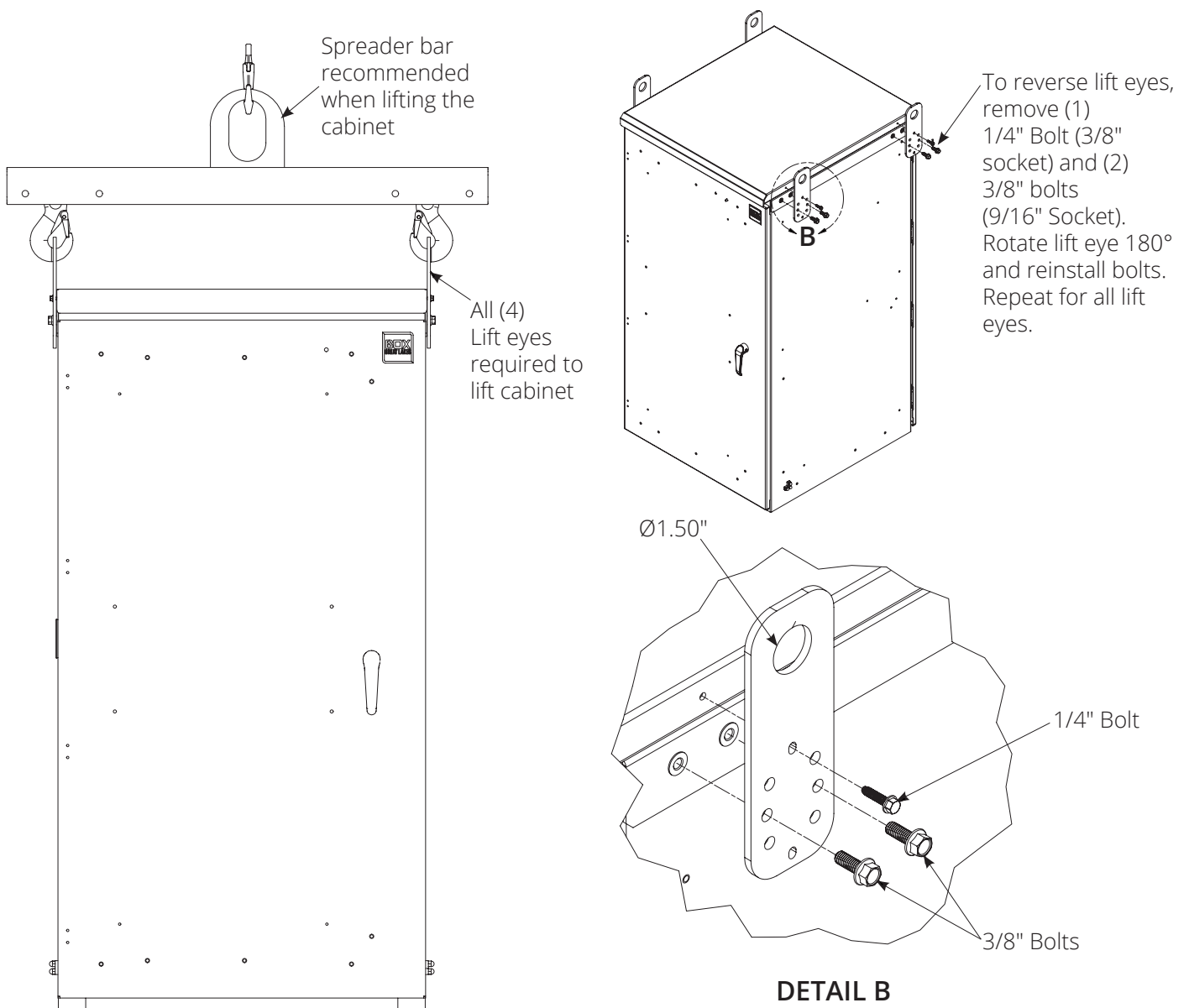

# PRIOR TO ANCHORING THE CABINET

## CONCRETE PAD RECOMMENDATIONS

It is recommended to install the **BOX** cabinet on a new concrete pad poured in accordance with applicable local building codes and industry standards.

Pad thickness is recommended to be 4" minimum. Extension beyond cabinet is recommended to be minimum 8" in all directions.

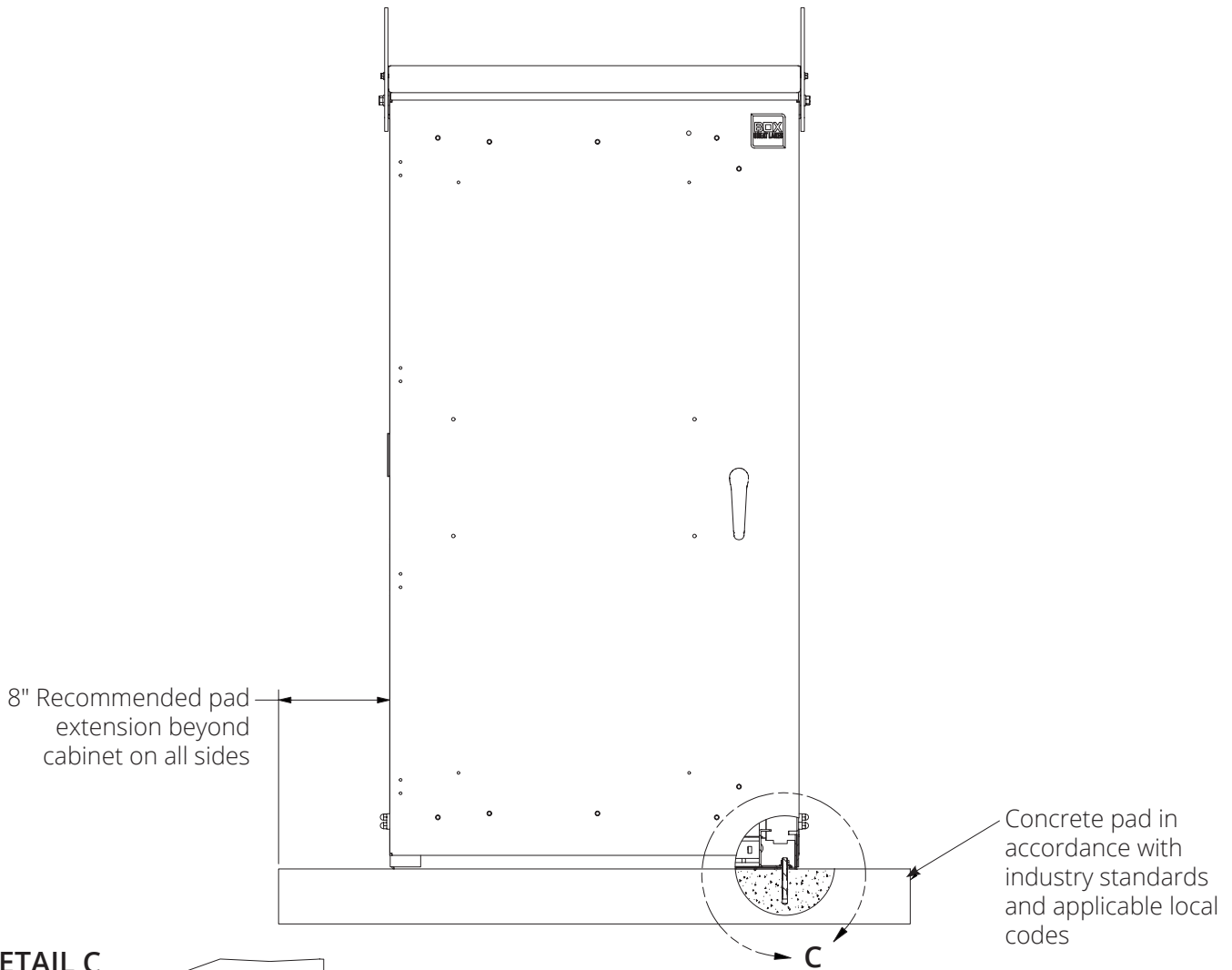

### DETAIL C

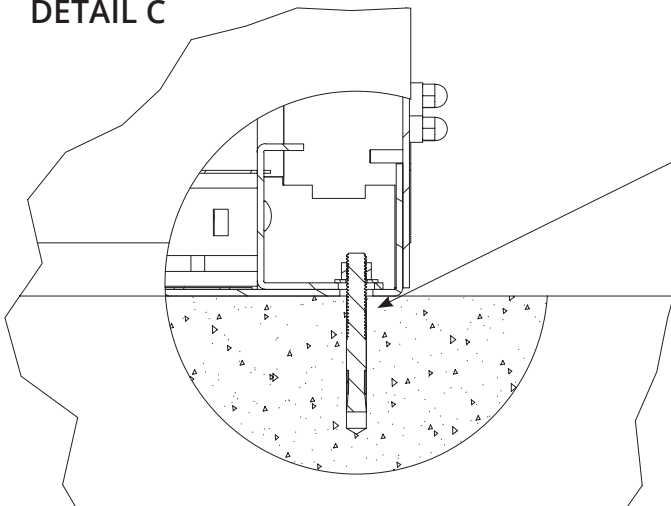

If using a wet concrete template, anchoring hardware is included with the template. See *Anchoring the Cabinet with Concrete Template*, page 12; Wedge anchors are recommended for anchoring. Install according to manufacturer's specifications. Great Lakes recommends **Hilti Brand: Kwik Bolt TZ2 Wedge Anchor Stainless Steel 304, 1/2" x 4 1/2"** (Part No. 2210261) or equivalent

## ANCHOR METHODS:

### OPTION 1: CABINET (WITH A RISER OR PLINTH) AND A WET CONCRETE TEMPLATE

Concrete template is embedded into a freshly poured concrete pad. The templates are designed to create a permanent anchoring point that alleviates measuring and drilling anchor holes.

1. Ensure included coil bolts and coil wing nuts are securely fastened to template.
2. Insert concrete template into wet concrete so under side of top flange is resting on surface of concrete. **DETAIL D**
  - a. Be sure template is level and located correctly in pad; 8" concrete extension beyond cabinet on all sides is recommended.
3. Allow concrete to set.
4. Once concrete is set, use 1-1/8" socket to remove all (6) coil bolts. **Do not discard**, hardware is used in step 6.

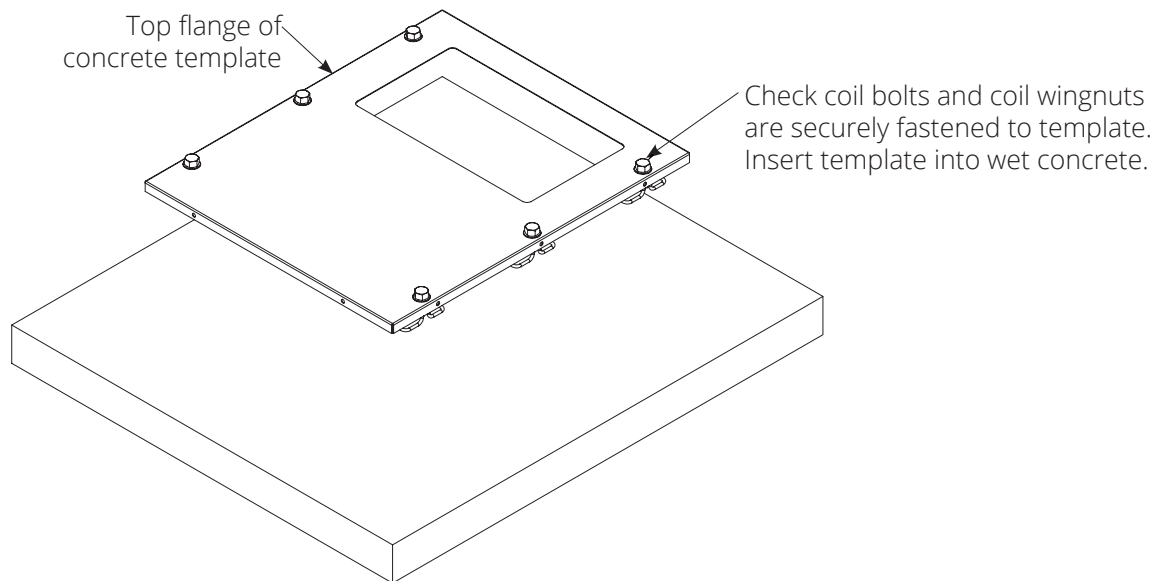

Insert template so under side of top flange is resting on surface of concrete. Be sure template is level and located correctly in pad. Allow concrete to set.

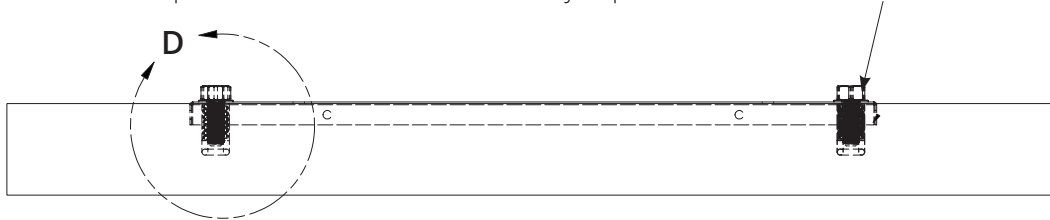

#### DETAIL D

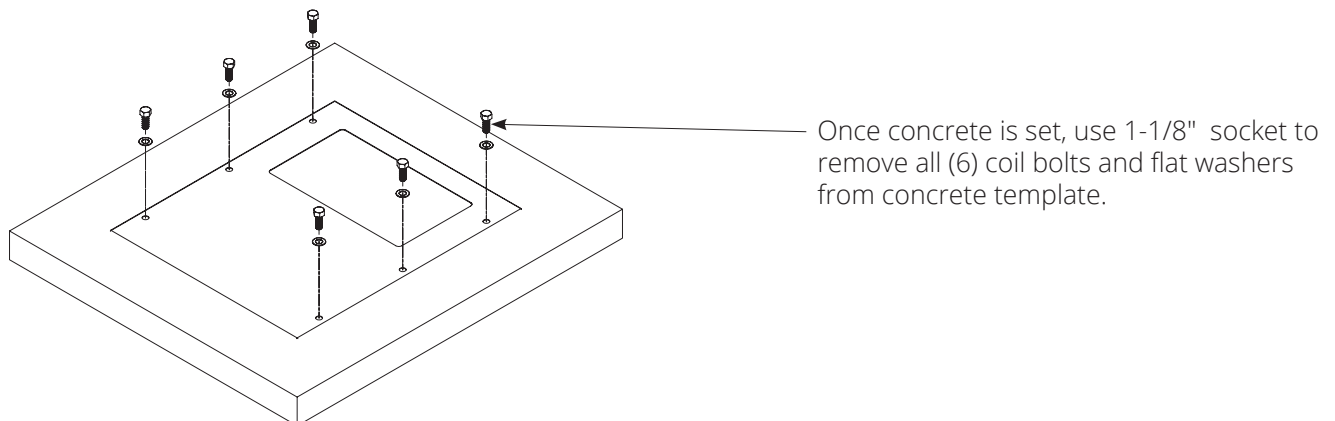
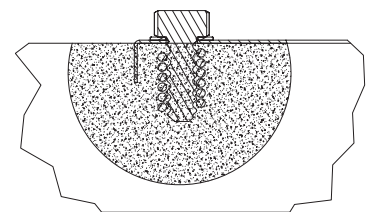

## ANCHOR METHODS:

### OPTION 1: CABINET (WITH A RISER OR PLINTH) AND A WET CONCRETE TEMPLATE (CONTINUED)

5. Place riser onto pad; ensure larger through-holes are on the bottom of the riser and align with concrete template holes.
6. Fasten riser to concrete template by using 1-1/8" socket to replace (6) coil bolts and flat washers. Bolts come pre-greased from the factory; if additional grease is needed, use Permatex 80345 White Lithium Grease or equivalent.
7. Install cabinet on riser
  - a. Use lift eyes to place cabinet on riser; see page 10.
  - b. Ensure cabinet mounting holes align with plinth mounting holes.
  - c. Secure cabinet to riser, use 9/16" socket to fasten (6) 3/8" hex bolts and washers (included with cabinet and riser). **DETAIL E**

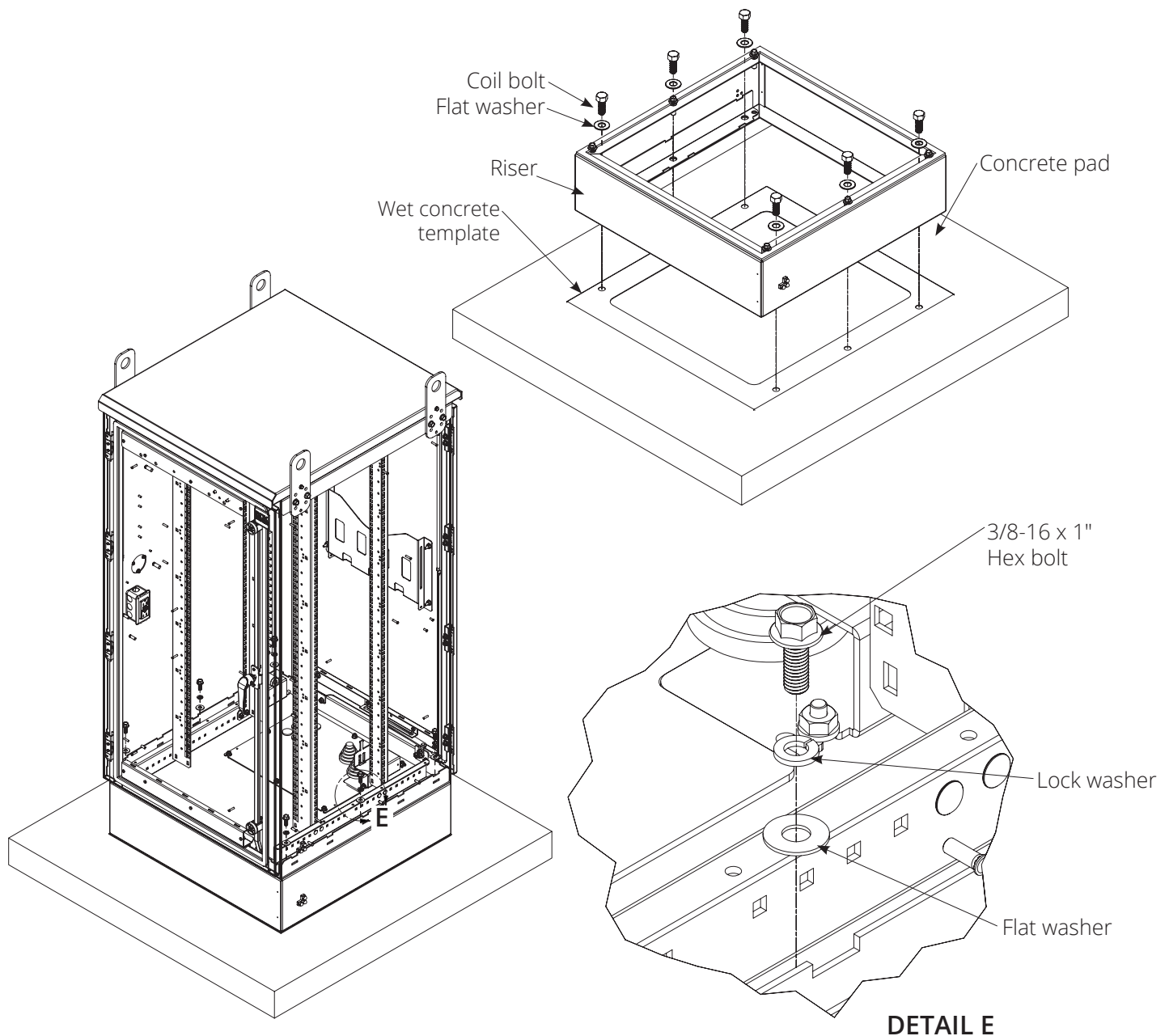

# ANCHOR METHODS:

## OPTION 2: CABINET (WITH A RISER OR PLINTH) DIRECTLY TO CONCRETE

### READ PRIOR TO SECURING CABINET

Riser/Plinth mounting profiles are detailed below. The cabinet is anchored with (6) holes in the bottom of a plinth/riser. The riser/plinth should be anchored with the center (2)  $\varnothing .780''$  holes and either the (4) remaining  $\varnothing .780''$  holes or the (4)  $\varnothing .531''$  holes.

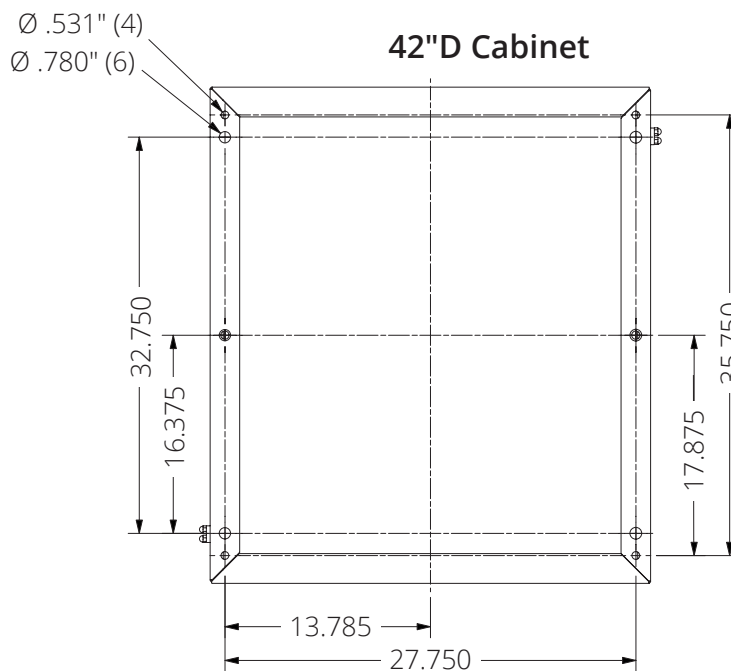
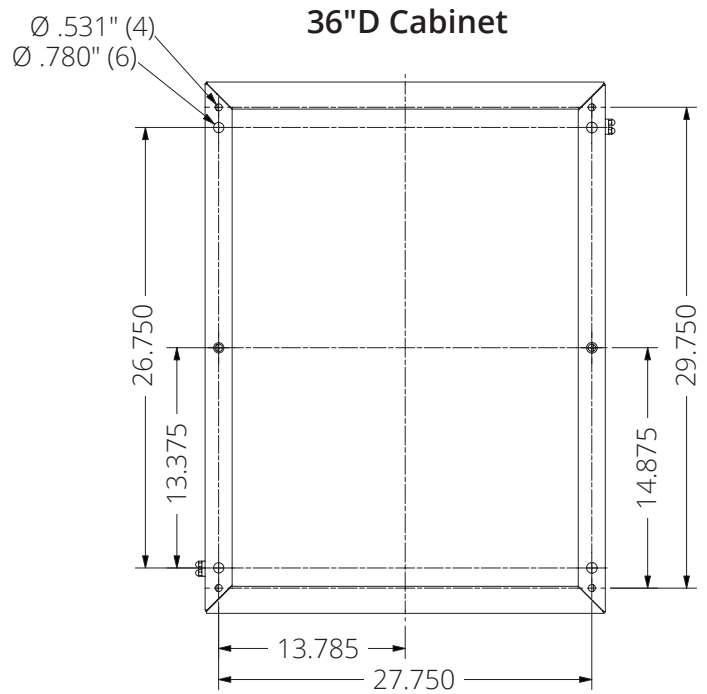
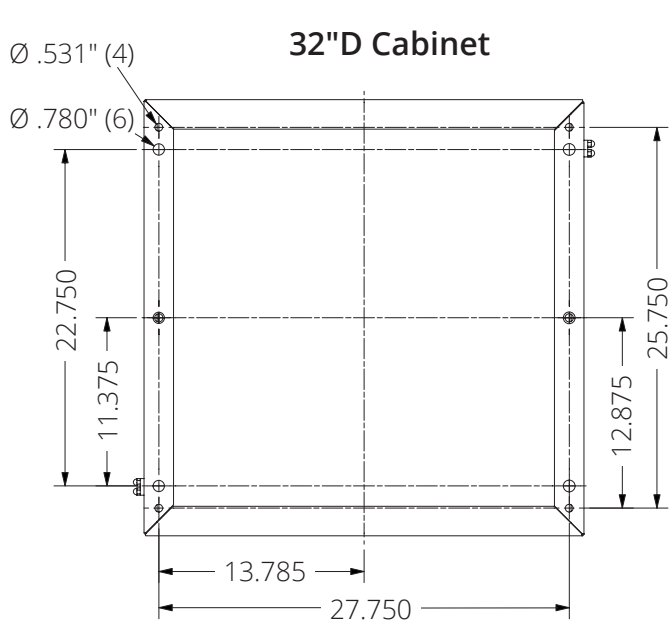

## ANCHOR METHODS:

### OPTION 2: CABINET (WITH A RISER OR PLINTH) DIRECTLY TO CONCRETE (CONTINUED)

1. Drill (6) appropriately sized holes to proper depth according to wedge anchor manufacturers specifications; See cabinet mounting profile on page 14 for spacing dimensions.
2. Insert wedge anchors into drilled holes.
3. Remove nut and washer from all wedge anchors.
4. Place riser onto wedge anchors, ensure riser gasket and threaded holes are up (cabinet side).
5. Secure riser to concrete pad by fastening wedge anchor washers and nuts according to manufacturer's specifications.

### NOTE: WEDGE ANCHOR HARDWARE NOT INCLUDED.

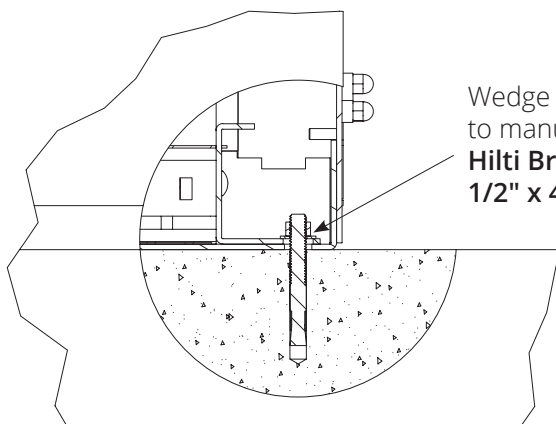
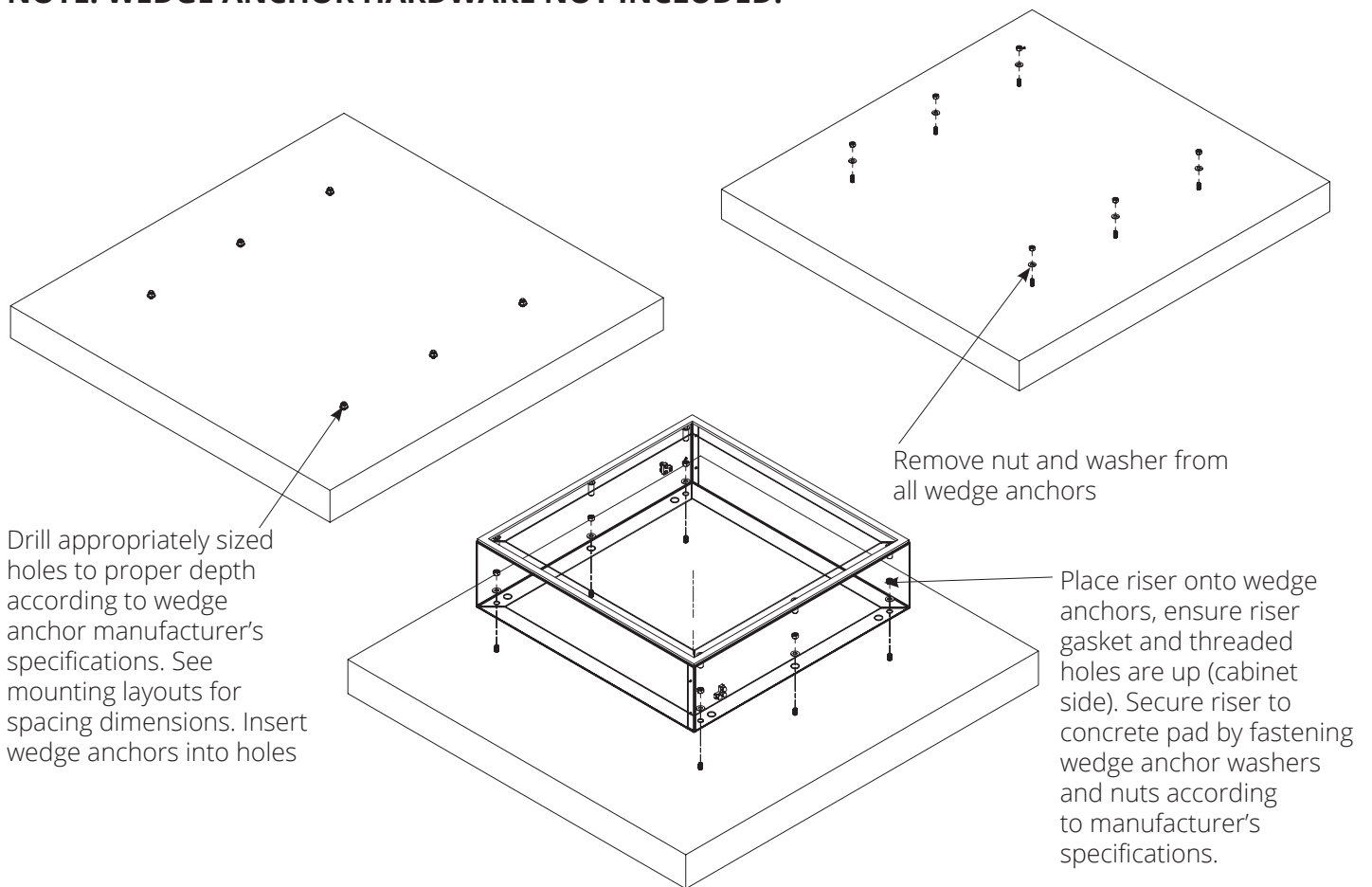

Wedge anchors are recommended for anchoring. Install according to manufacturer's specifications. Great Lakes recommends **Hilti Brand: Kwik Bolt T22 Wedge Anchor Stainless Steel 304, 1/2" x 4 1/2" (Part No. 2210261) or equivalent**

## ANCHOR METHODS:

### OPTION 2: CABINET (WITH A RISER OR PLINTH) DIRECTLY TO CONCRETE (CONTINUED)

- Using all four lift eyes (see page 10), place cabinet onto riser, making sure that (6) mounting holes are aligned between the cabinet and riser.
- Secure cabinet to riser by fastening included (6) 3/8" hex bolts (9/16" socket) and washers.

#### DETAIL F

**NOTE: WEDGE ANCHOR HARDWARE NOT INCLUDED.**

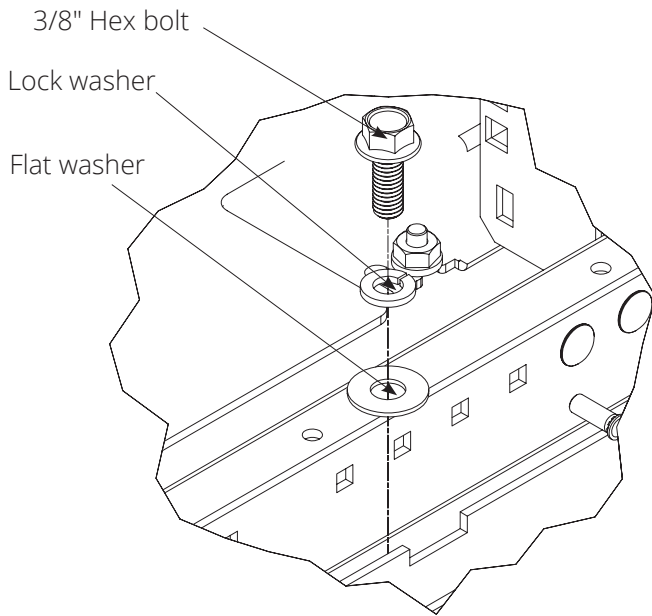

DETAIL F

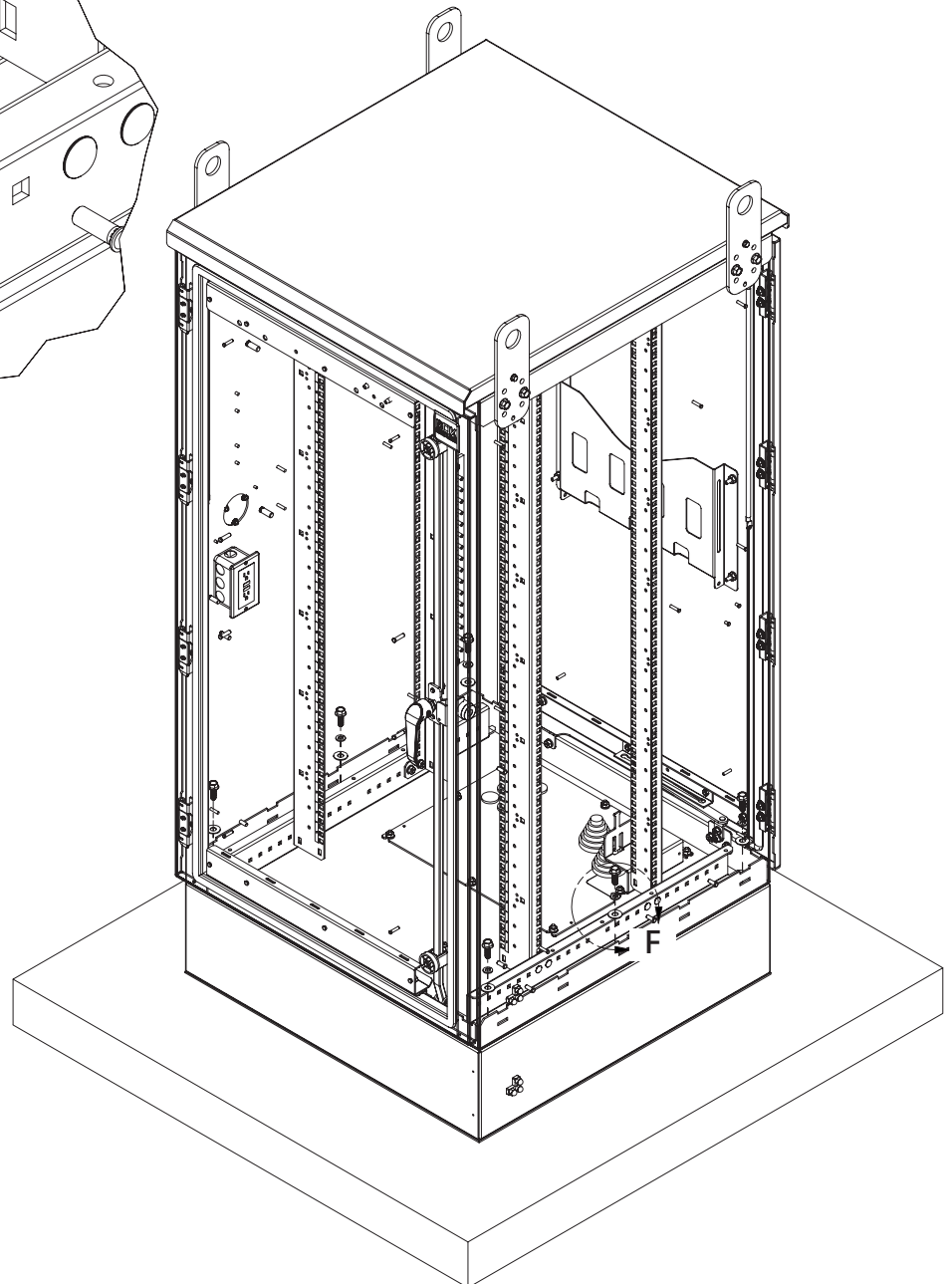

# ANCHOR METHODS:

## OPTION 3: CABINET (WITHOUT A RISER OR PLINTH) DIRECTLY TO CONCRETE

### READ PRIOR TO SECURING CABINET

The cabinet is anchored with (6) holes in the bottom of the cabinet. Gland plate/bottom access dimensions are also shown in case utility lines will be inserted into the cabinet from below grade. Refer to page 21 to remove gland plate.

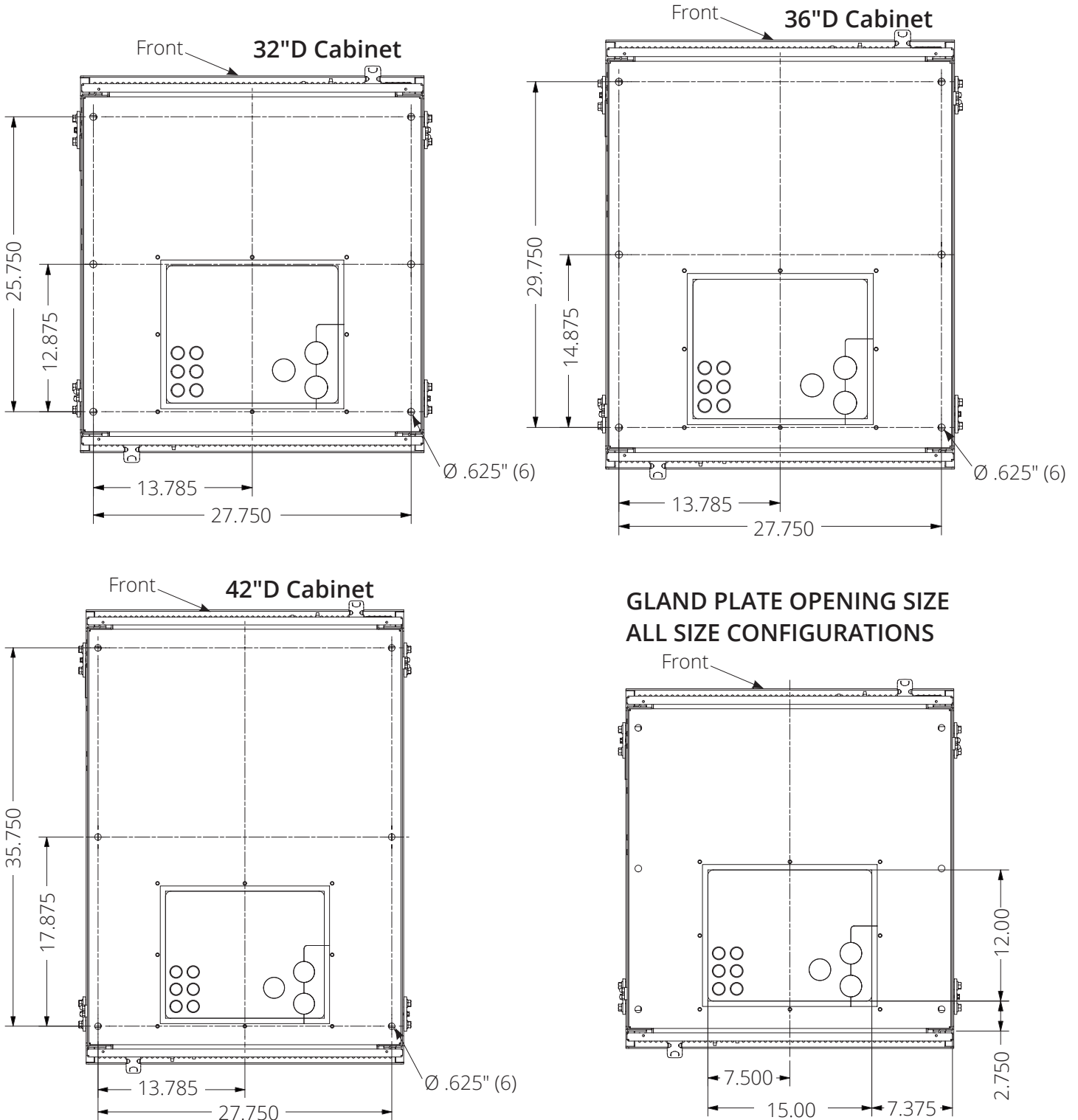

## ANCHOR METHODS:

### OPTION 3: CABINET (WITHOUT A RISER OR PLINTH) DIRECTLY TO CONCRETE (CONTINUED)

1. Drill (6) appropriately sized holes to proper depth according to wedge anchor manufacturers specifications; See cabinet mounting profile on page 17 for spacing dimensions.
2. Insert wedge anchors into drilled holes.
3. Remove nut and washer from all wedge anchors.
4. Using all four lift eyes (see page 10), place cabinet onto wedge anchors.
5. Secure cabinet to concrete pad by fastening wedge anchors according to manufacturer's specifications.

#### NOTE: WEDGE ANCHOR HARDWARE NOT INCLUDED.

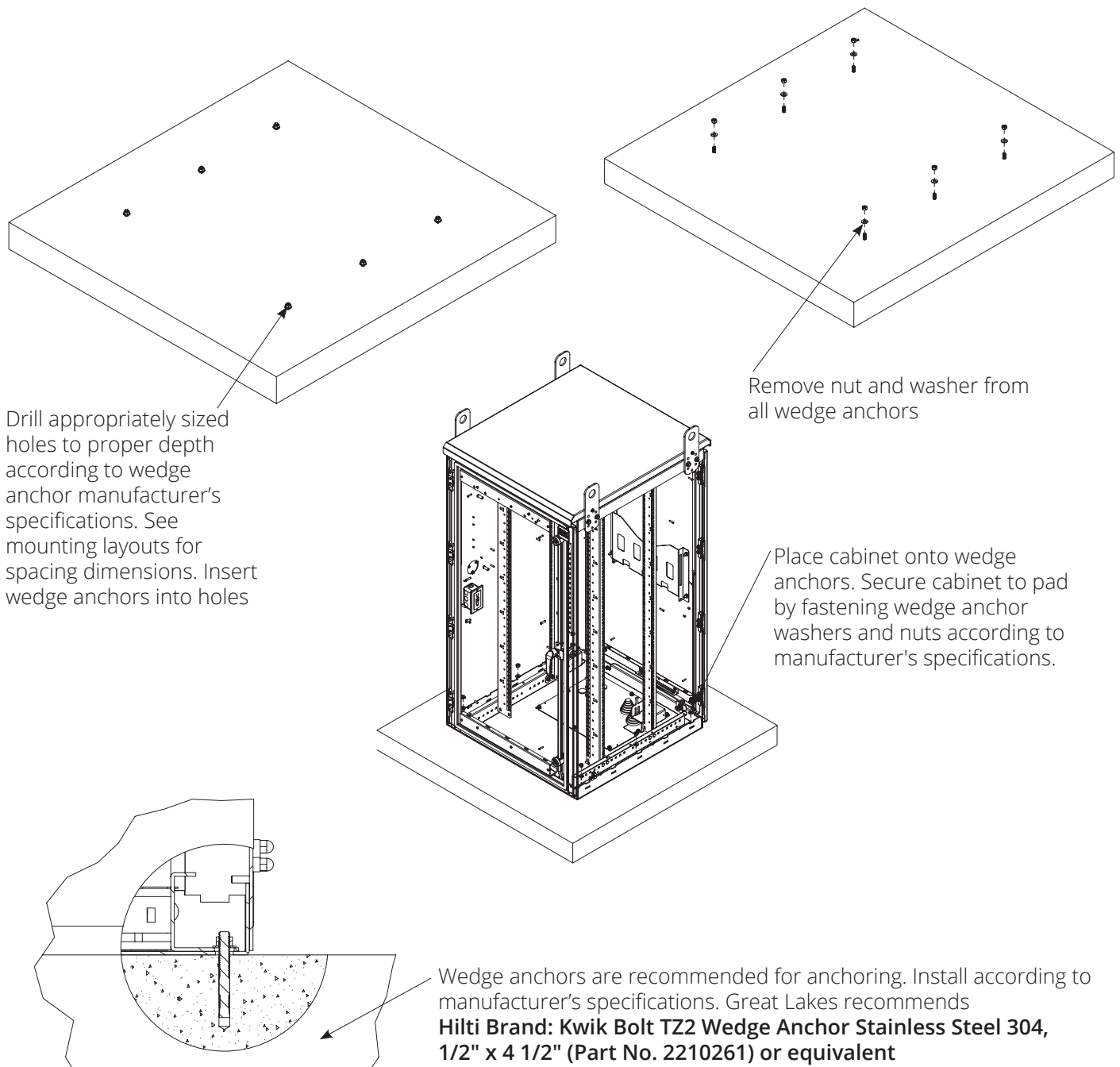

## DOOR AND DOOR HANDLE

The cabinet includes three-point latching front and rear doors with 1/4 turn handles compatible with a padlock (Ø.413" max. shackle).

### To open door:

1. Rotate 1/4 turn handle clockwise to open door.
2. Open door until wind stop engages.

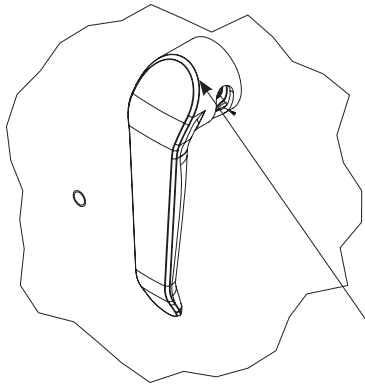

**DETAIL G**

1/4 Turn handle can accept padlock with Ø.413" max shackle

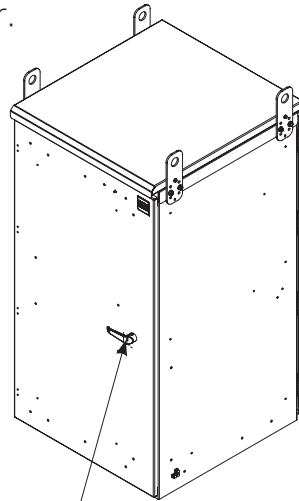

Rotate 1/4 turn handle clockwise to open door

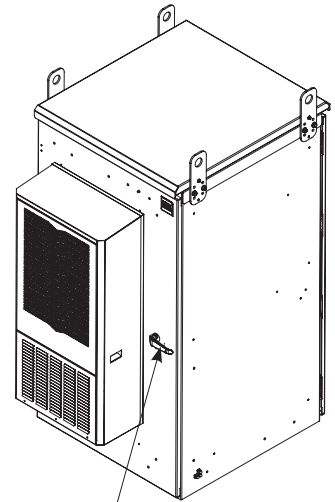

Note: If HVAC is installed handle will turn counter clockwise

### To close door:

1. Disengage wind stop plunger by lifting wind stop plunger at bottom of door. **DETAIL H**
2. Swing door closed while handle remains in open position. Apply slight pressure against the cabinet frame to make sure all three points will close.
3. Turn handle 1/4 turn in opposite direction to secure door shut.

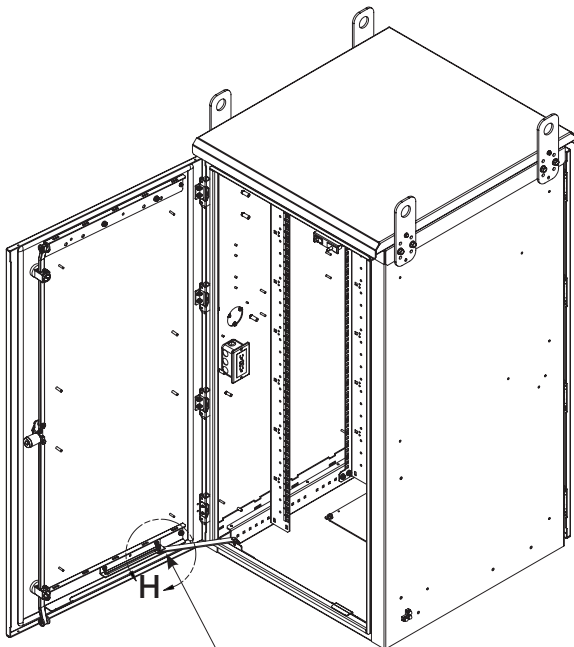

Disengage wind stop plunger. Push door closed. Turn handle 1/4 turn in opposite direction from opening to secure door shut.

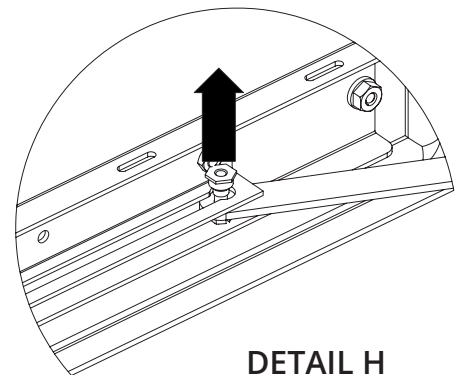

**DETAIL H**

## DOOR AND DOOR HANDLE (CONTINUED)

### To remove door:

1. Remove wind stop bolt (13 mm socket) and nut (10 mm socket). **DETAIL I**
2. Move swing arm out of way.
3. Retract all hinge pins. **DETAIL J**
4. Carefully pull the door away from all hinges.

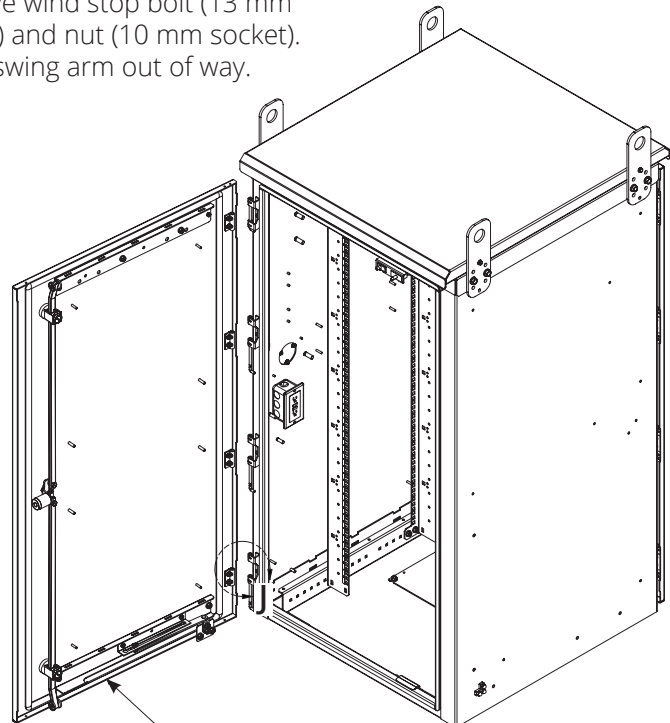
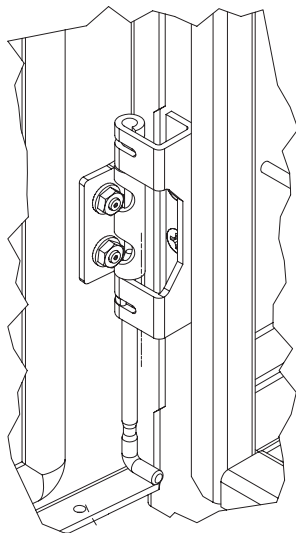
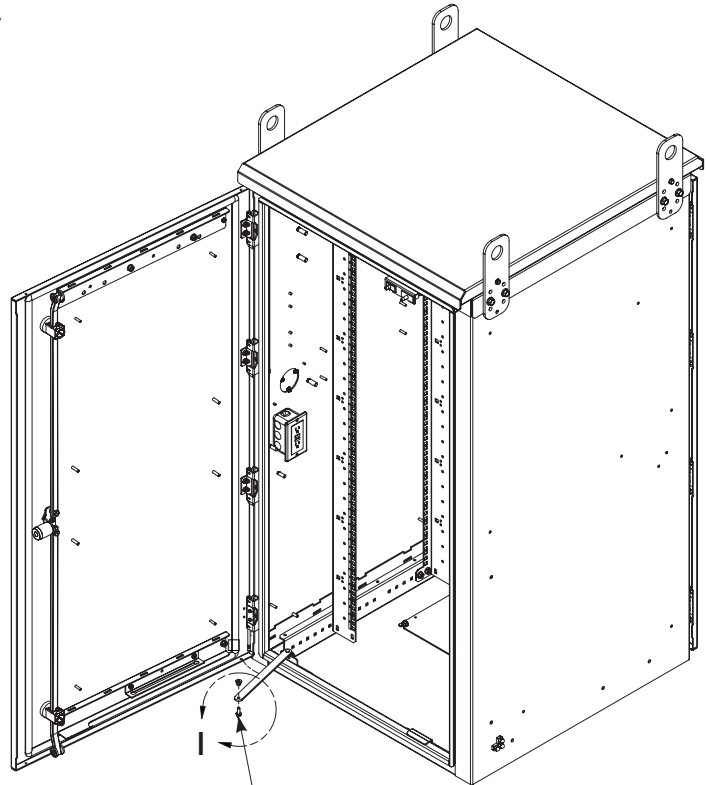
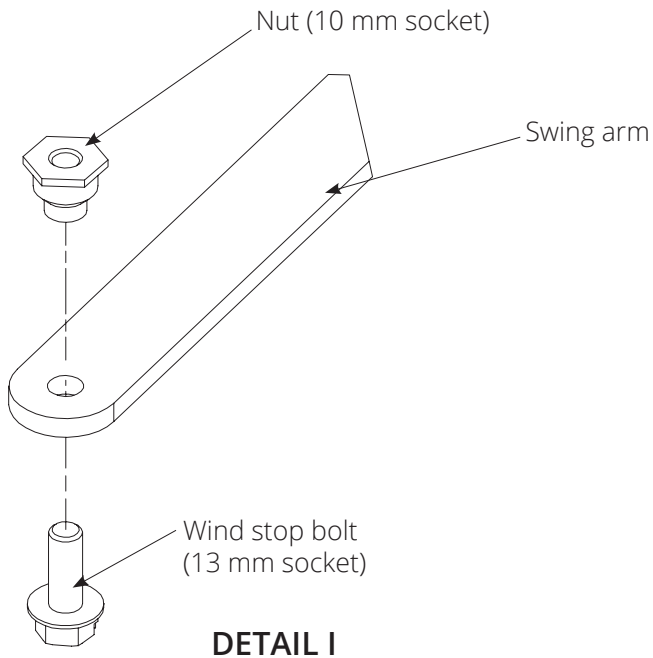

## GLAND PLATE & GROMMETS

All **BOX** cabinets will ship from factory with a gland plate installed to seal the bottom access cutout.

### To remove gland plate:

1. Use 1/2" socket to remove (8) 1/4"-20 flange nuts from surface of gland plate.
2. Lift and remove gland plate from cabinet.

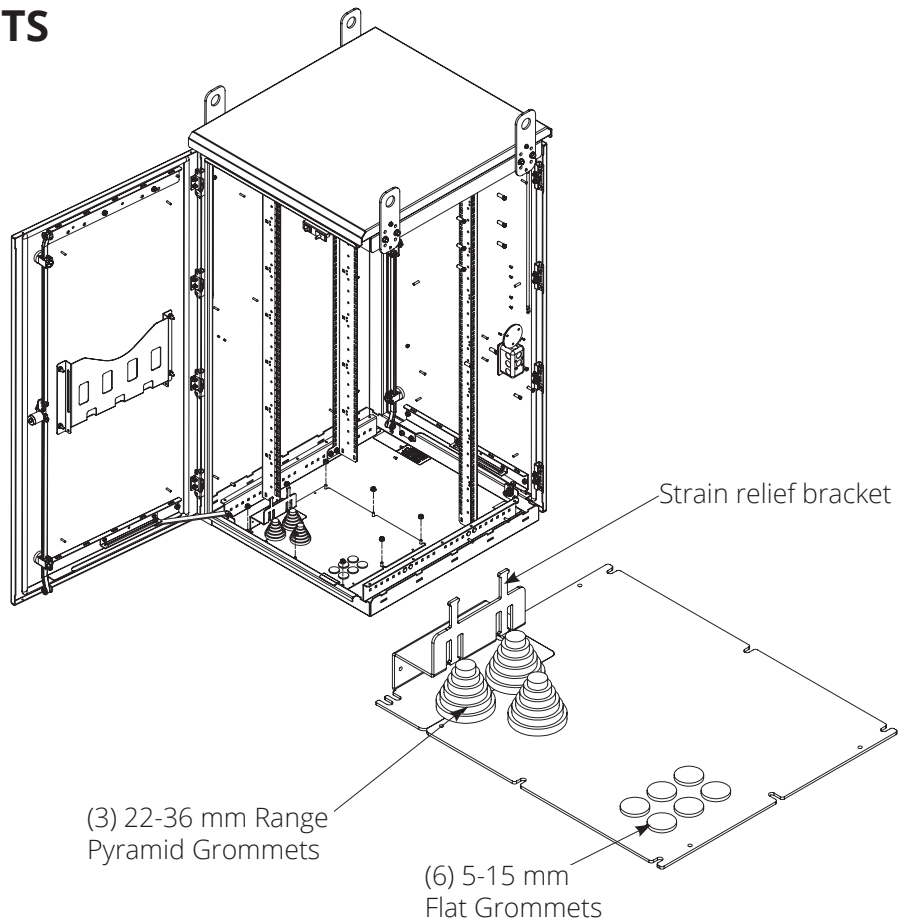

### Pyramid grommet installation

1. Remove gland plate if there is no access to the bottom side of gland plate
2. Remove locknut from bottom of pyramid grommet
3. Insert pyramid grommet into gland plate hole so that pyramid is facing up and the threaded portion is protruding through the gland plate
4. Thread locknut onto bottom side of grommet

### Inserting cable through pyramid grommet

1. Measure diameter of cable
2. Locate corresponding diameter molded into stepped portion of grommet
3. Cut around the circumference of the grommet just above the molded diameter text found in step 2
4. Insert cable through grommet

### Flat grommet installation

1. Press grommet into gland plate hole until it is fully seated making sure that text molded into grommet is facing up

### Inserting cable through flat grommet

1. Measure diameter of cable
2. Locate corresponding diameter on grommet
3. Pierce/cut the grommet along recessed area corresponding to cable diameter
4. Tear along remaining recessed area to remove material from center of grommet
5. Insert cable through grommet

# MOUNTING RAIL ADJUSTMENT

Two pairs of powder coated mounting rails for 19" or 23" EIA are installed in the **BOX** cabinet. The cabinet will ship from factory with rails set for 19" EIA, unless specified for 23" at the time of order. The customer can also convert rails from 19" to 23" mounting. Universal 3/8" square (M6) rails with RMU labels are standard.

## RAIL DEPTH ADJUSTMENT

**Do not attempt to adjust rails once equipment has been loaded.**

1. To adjust rail depth, remove (4) 1/4" flanged hex nut (7/16" socket) and (4) 1/4"-20 X 1/2" carriage bolt from top and bottom of mounting rail. **DETAIL K**
2. Move rail to desired location and reapply 1/4" hardware.
3. Repeat for opposite front rail.

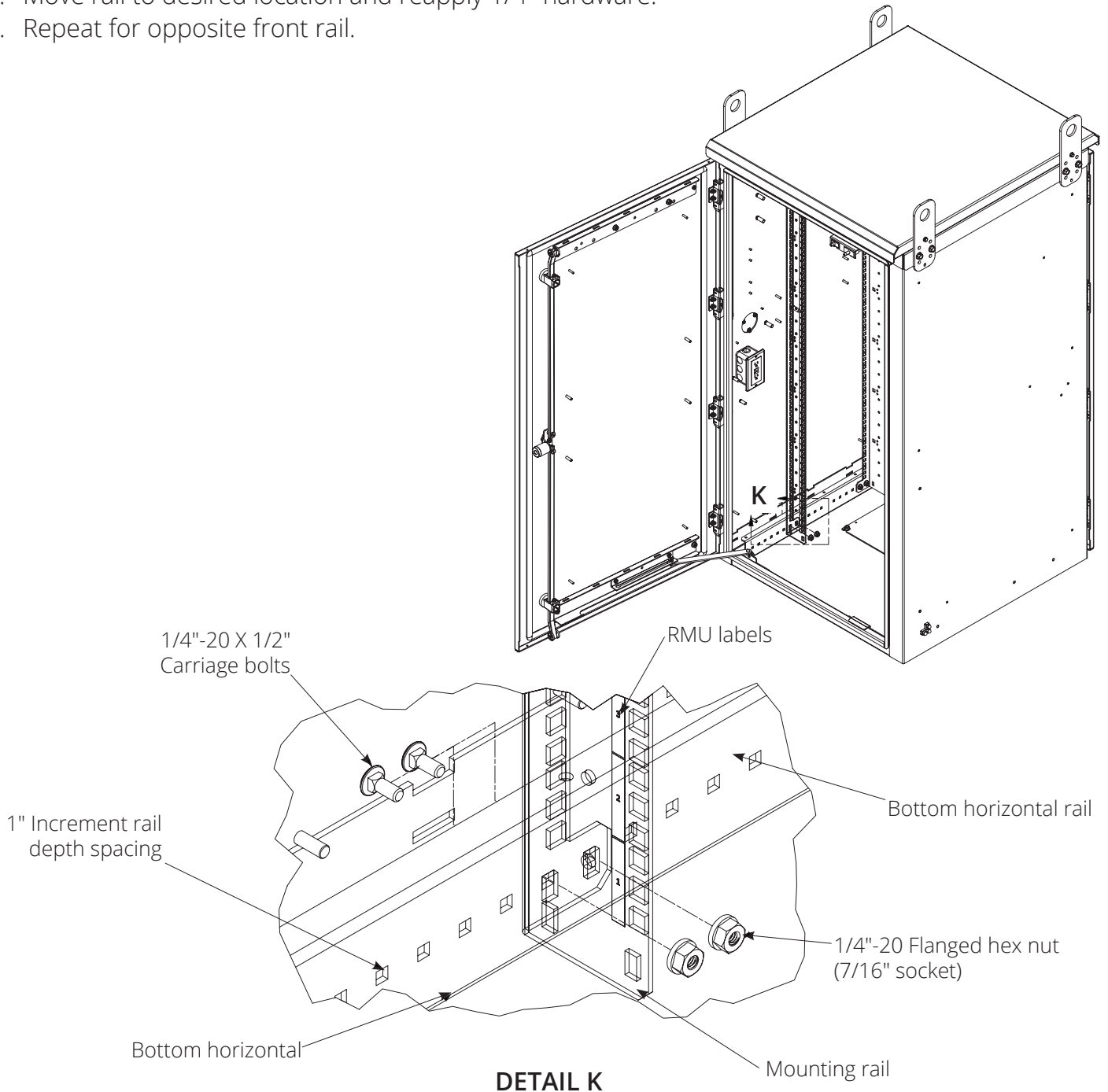

## 19" TO 23" EIA MOUNTING RAIL ORIENTATION

**Do not attempt to adjust rails once equipment has been loaded.**

To adjust EIA spacing, use 7/16" socket to remove (4) 1/4" flanged hex nut and (4) 1/4"-20 X 1/2" carriage bolt from top and bottom of mounting rail. **DETAIL L**

1. Rotate the rail so that the secondary rail face is toward the front of the cabinet. **DETAIL L**

**NOTE:** Tab should be facing front of cabinet pointing at center of cabinet

2. Reapply 1/4" hardware.
3. Repeat for all rails.

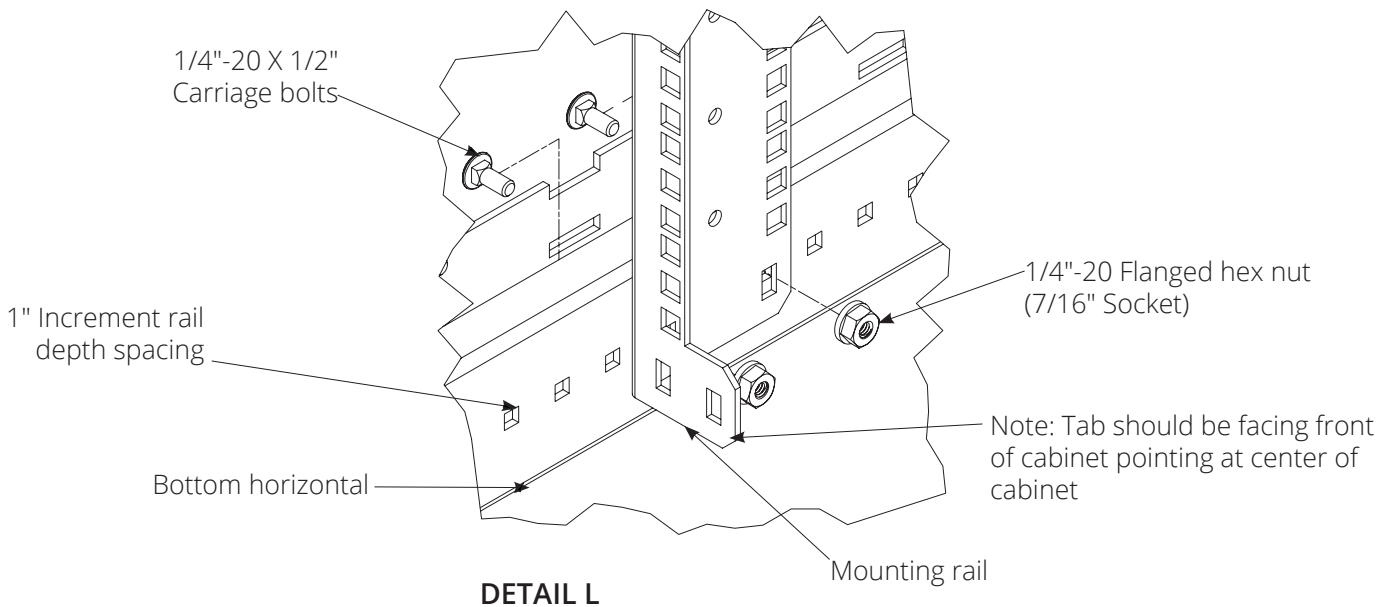
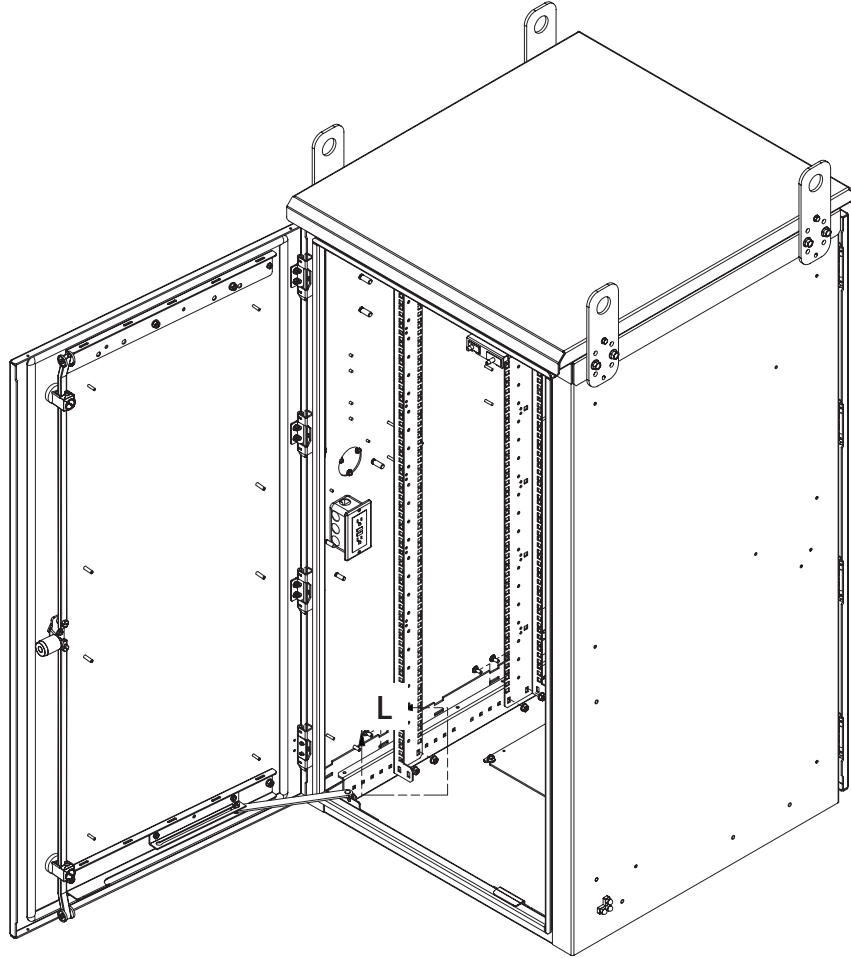

# GROUNDING

## PROTECTIVE GROUNDING

Protective grounding studs to ground the cabinet can be found on both of the outside lower corners of the cabinet. **DETAIL M**

Plinths and risers also have grounding studs on both outside lower corners.

(3) Grounding studs are included so that double hole grounding lugs can be oriented in a vertical or horizontal orientation. Grounding studs are 1/4"-20 threads with .63" spacing. Acorn nuts and masking plates must be removed to fasten grounding lug to studs; acorn nuts and masking plate can be discarded after removal.

### See Protective Grounding Warnings on page 25

If applicable, cabinet should be grounded according to most recent revision, or most recently locally accepted version, of Article 250 of NFPA 70® (NEC®).

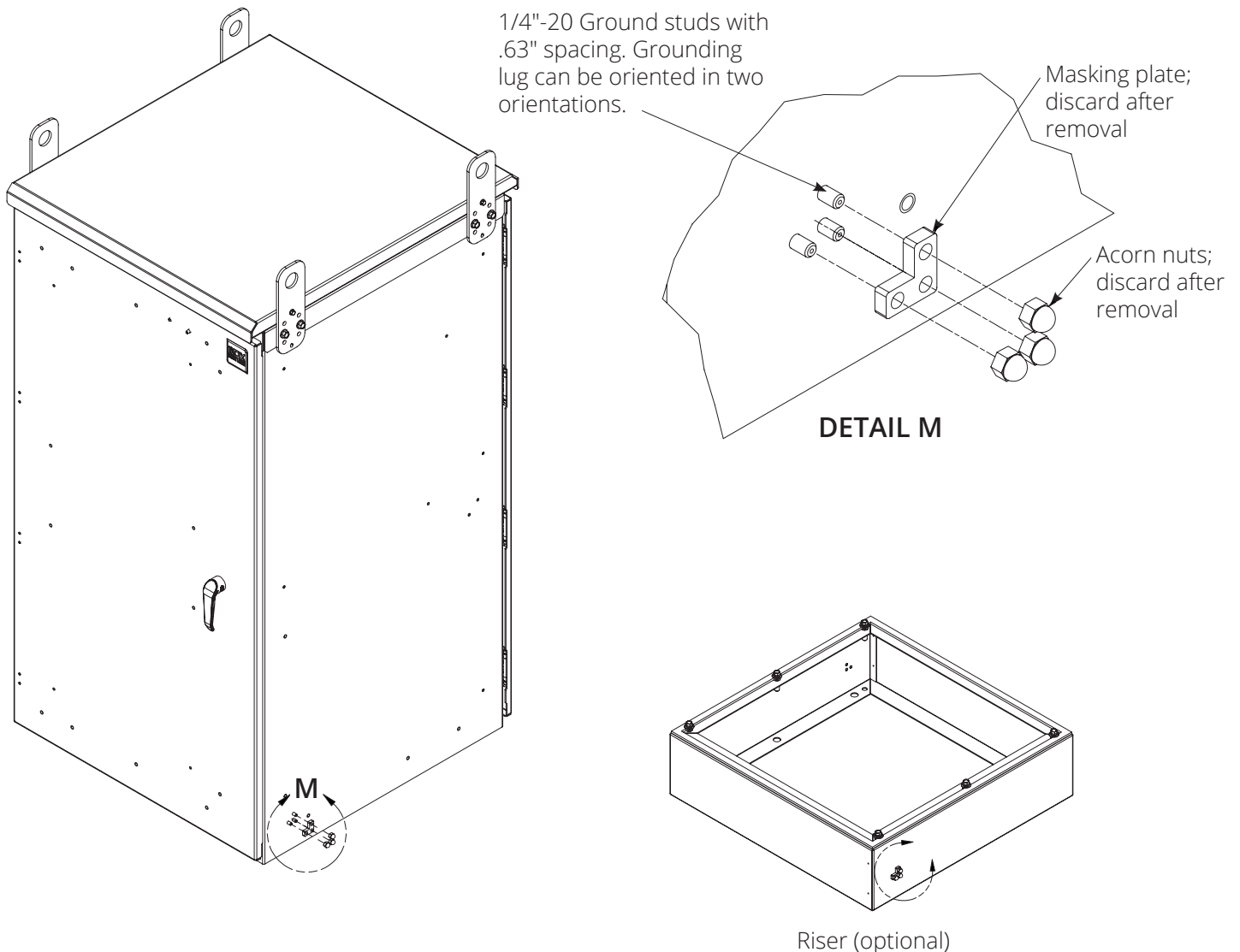

# GROUNDING

## PROTECTIVE GROUNDING

Protective grounding studs are provided along with grounding jumper wires that electrically bond the cabinet doors to the cabinet frame.



**WARNING:** To avoid injury to persons or loss of life, ground each cabinet individually to the dedicated branch circuit ground.

## Connecting Main Protective Grounding Stud to the Dedicated Branch Circuit Ground

Connect the dedicated branch circuit ground connector to the main protective grounding stud located outside at the bottom of the cabinet frame using a listed ring or closed-loop terminal.

## Connecting Main Protective Grounding Stud to the Protective Bonding Conductors

Doors are bonded to the top of the cabinet chassis using a listed ring or closed-loop terminal.

## Parts Not Bonded to Protective Earthing Terminal

The following parts are not effectively bonded to the protective earthing terminal: rails, document holder, solar shield, and terminal block panel. If these parts need to be bonded to the protective earthing terminal, do so in accordance with *Article 250 of the National Electric Code*.

## INTERNAL GROUNDING

Cabinets will come from the factory with a 16-position bus bar.  
Cabinets will also come from the factory with both doors bonded to the cabinet through permanent grounding studs and wire harnesses.

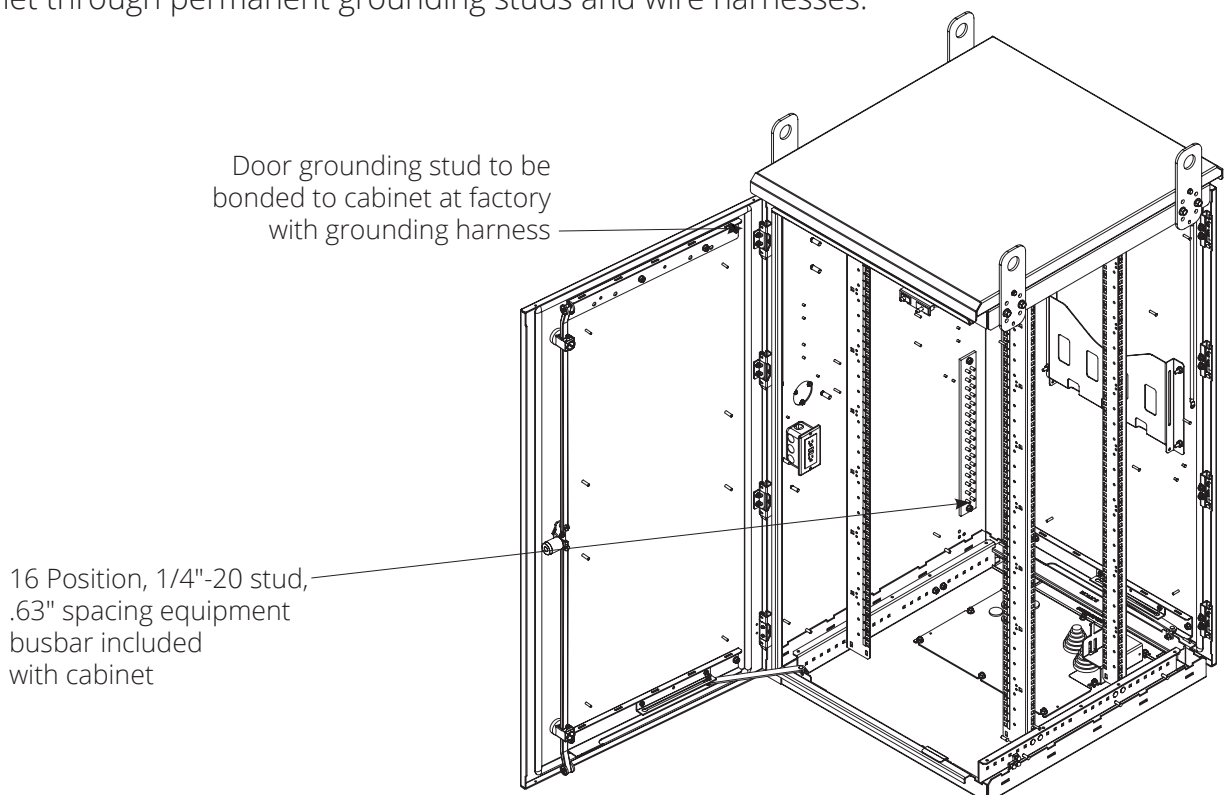

# TERMINAL BLOCK & RECEPTACLES

The terminal block, bus bar, and 15 AMP GFCI duplex receptacles are installed in standard locations from factory. Standard and optional mounting locations are pictured. Great Lakes will install in optional locations if specified at time of order.

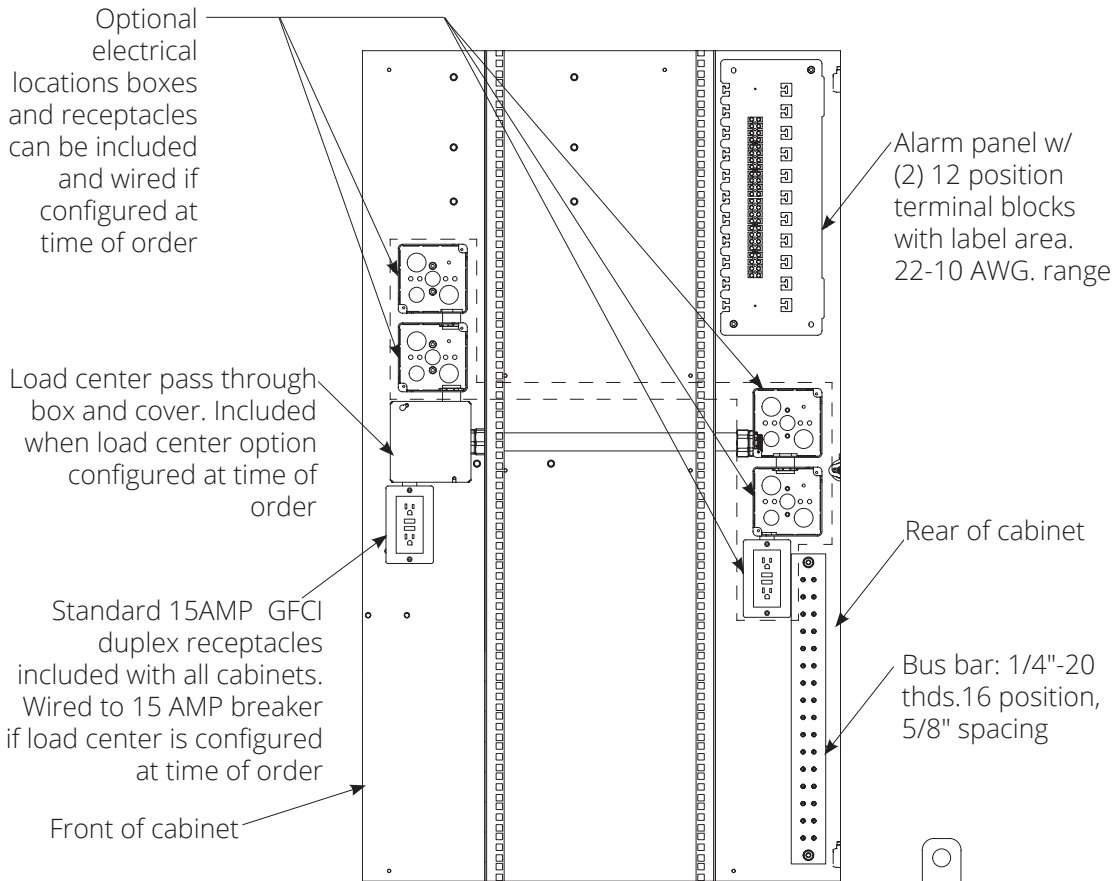

Electrical layout, left inside view

Alternate locations for the three standard electrical components are provided on the right side of the cabinet. Components can be removed from the left side and installed on the right side, if required. If insulation is present in cabinet, the break away sections can be removed for the respective location being used

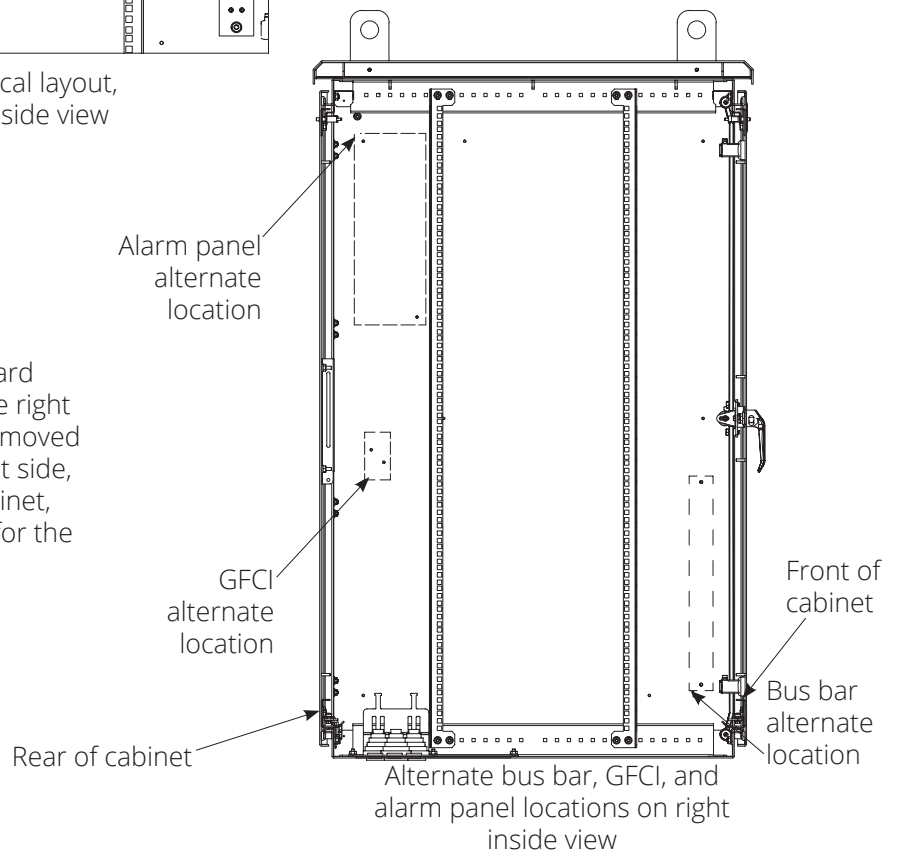

# LOAD CENTER & GENERATOR PLUG

BOX cabinets can be configured with optional load center and generator inlet box. Load center and generator inlet box are installed on the left side of the cabinet.

Part No.	Description	Compatible <b>BOX</b>
QO112M100PRB-SP	100 AMP main, 12 space; include surge protection	All BOX sizes
QO116M100PRB-SP	100 AMP main, 16 space; include surge protection	24, 30, 42 sizes
QO120M200PRB-SP	200 AMP main, 20 space; include surge protection	24, 30, 42 sizes
GPIB30A	30 AMP, L14-30P, 125/250 V, 7,500W	All BOX sizes
GPIB50A	50 AMP, SS2-50P, 125/250 V, 12,500 W	All BOX sizes

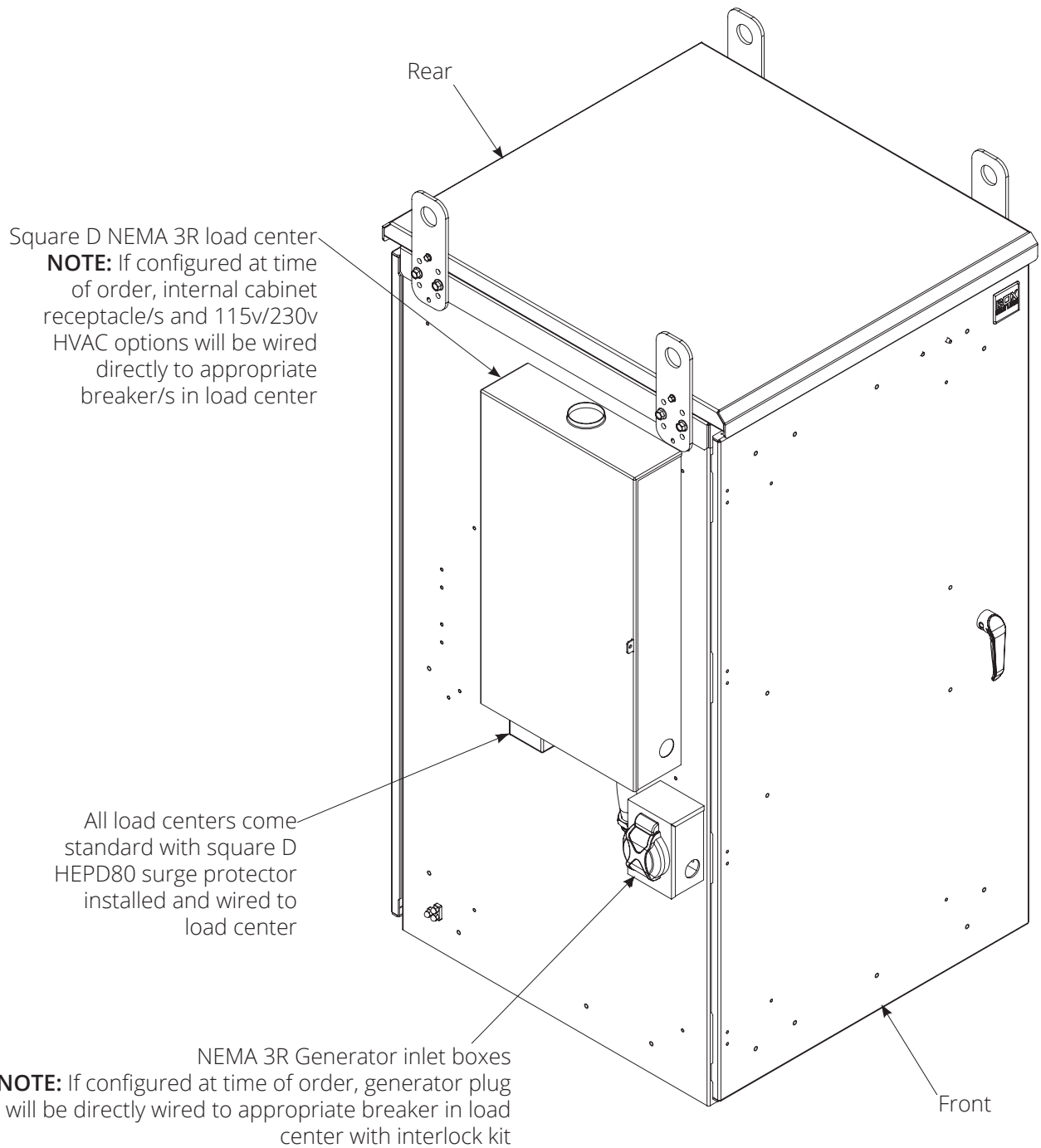

## CONFIGURATION OPTION - HVAC UNITS

Cabinets can be configured with an HVAC option installed on the front door of the cabinet. Door alarm switches (normally open/normally closed options) will come installed; terminals are available for alarms (not wired).

Cabinets can come configured with HVAC units per the part numbering matrix. HVAC units will come installed and wired (if optional load center is installed). Refer to included OEM manual for information on and operation of HVAC units.

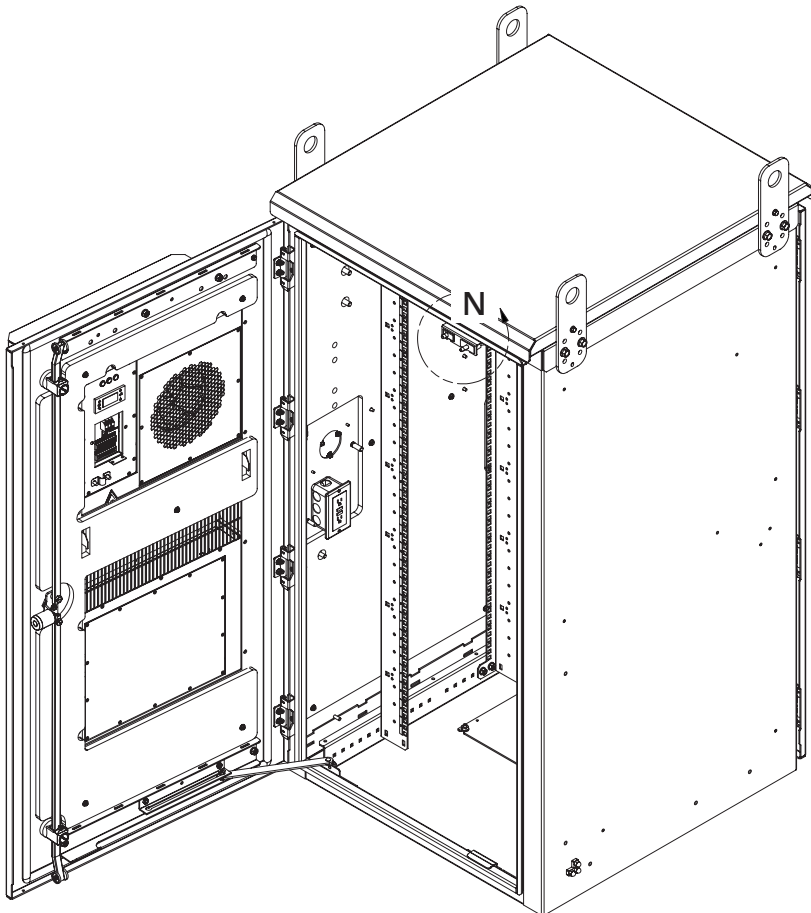
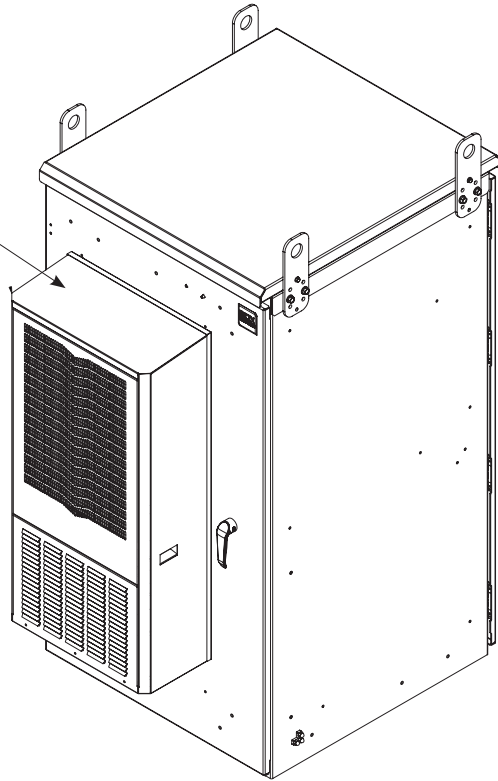

DETAIL N

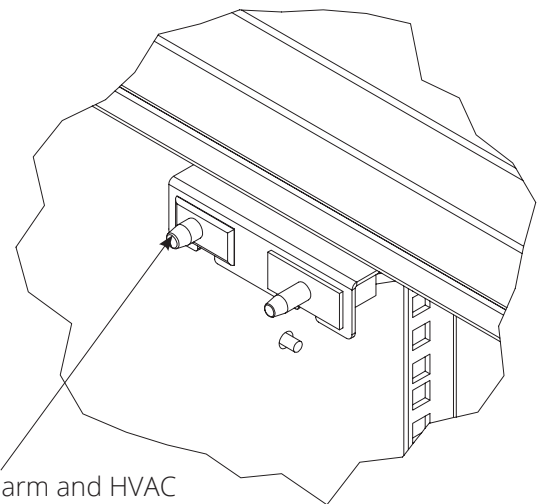

Alarm and HVAC shut off door switches will come installed.

# CONFIGURATION OPTION - 16" BATTERY PLINTH

16" battery plinths are available for **BOX** cabinets. Plinths are designed to be compatible with multiple lead acid batteries. Plinths come standard with access doors on the front and rear which can only be open when the BOX cabinet door is open. Note: 32"D Battery Plinth can only be used with 100 or 60 AH batteries

## To open access doors:

1. Rotate both slotted 1/4 turn latches.
2. Pull top of door out while simultaneously lifting up to remove door.

## To close access door:

1. Place lower portion of door onto plinth, ensuring bottom stiffener of door is engaged with flange on plinth.
2. Push top of door closed.
3. Rotate slotted 1/4 turn latches.

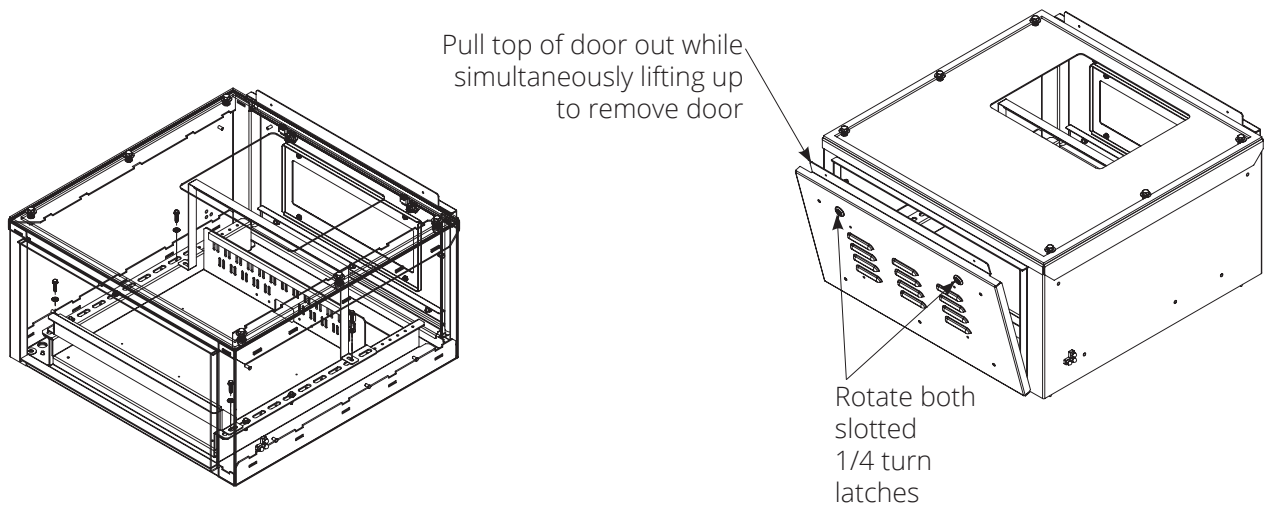
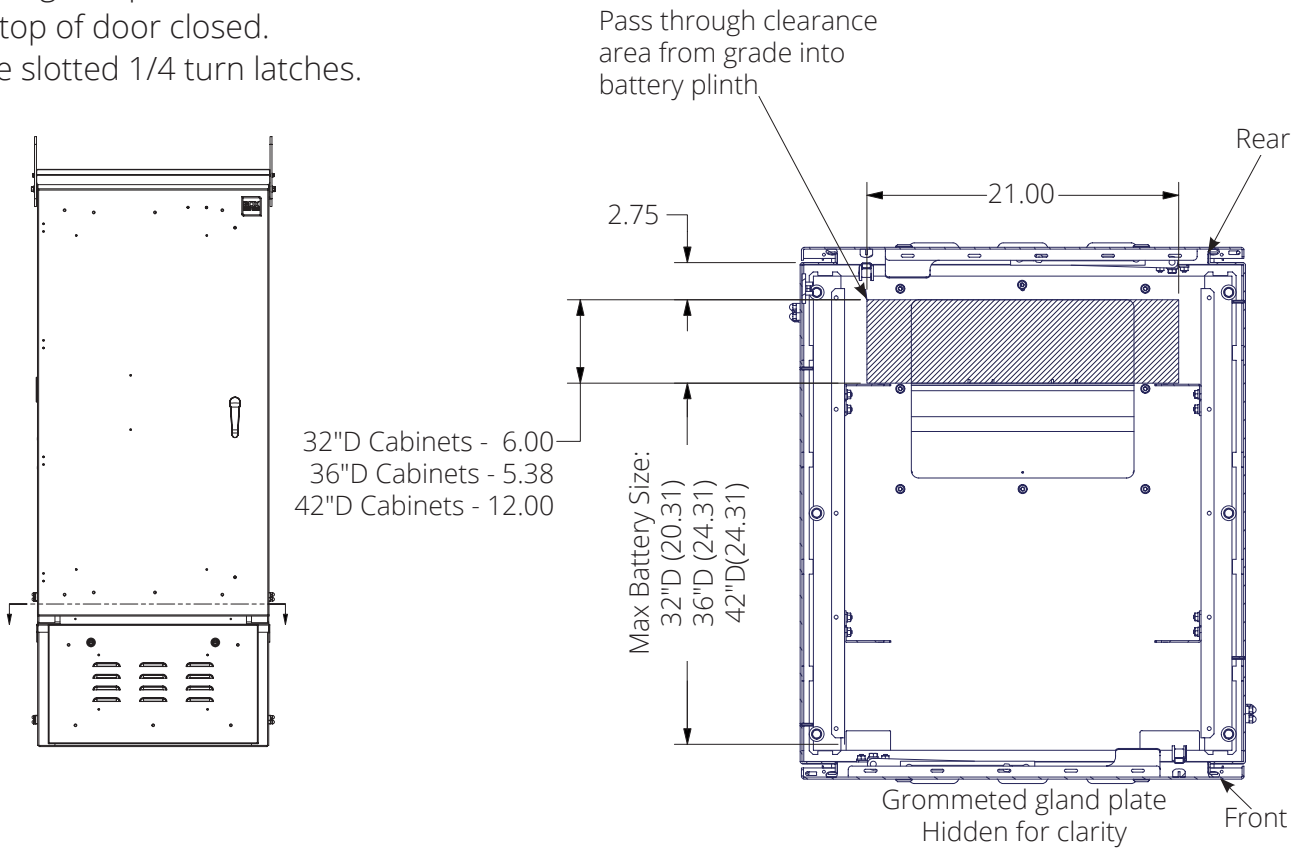

# OPTIONAL ACCESSORIES

## LAPTOP TRAY

A laptop tray can attach to the standard document holder (included on the rear door of the cabinet).

Part No.	Description	Compatible <b>BOX</b>
BX-LT8511	Laptop tray; fits 15"W laptop and provides 11.5" working depth	All BOX sizes

**To open laptop tray:** Disengage plungers on both sides of laptop tray and swing tray down.

**To close laptop tray:** Swing tray up until plungers engage.

**To install laptop tray:**

### STEP 1

- Remove document holder from cabinet door before assembling tray accessory
- Install support arms to document holder, **DETAIL O**
- All nuts to be installed onto bolts until they stop
- Attach laptop tray to document holder, **DETAIL P**

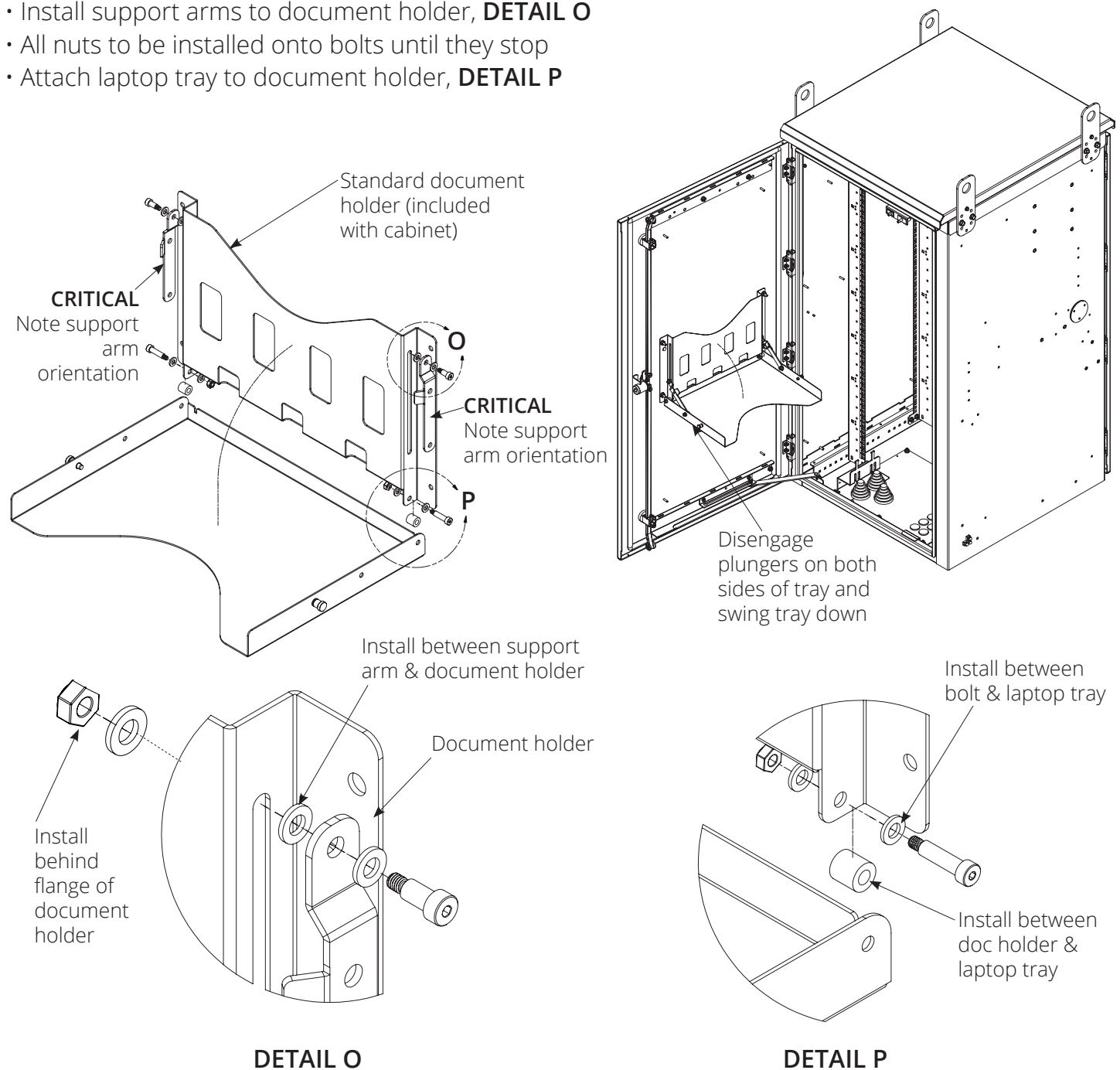

## OPTIONAL ACCESSORIES (LAPTOP TRAY CONTINUED)

### STEP 2

- Assemble support arms to laptop tray, **DETAIL Q**
- All nuts to be installed onto bolts until they stop

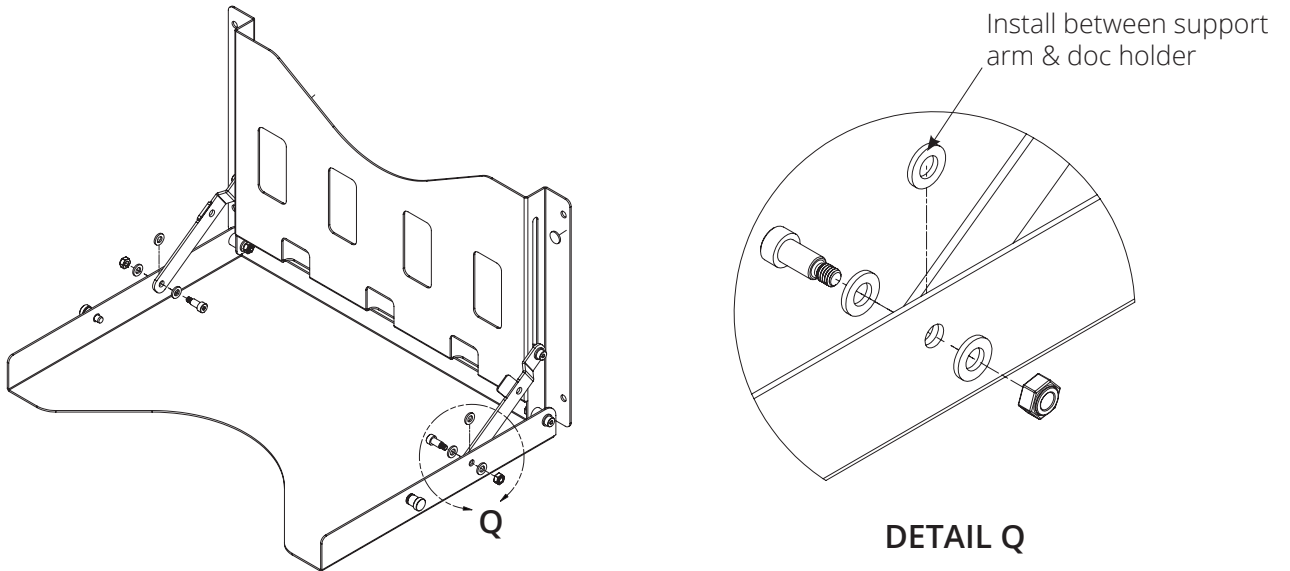

### STEP 3

- Install adhesive bumpers, **DETAIL R**

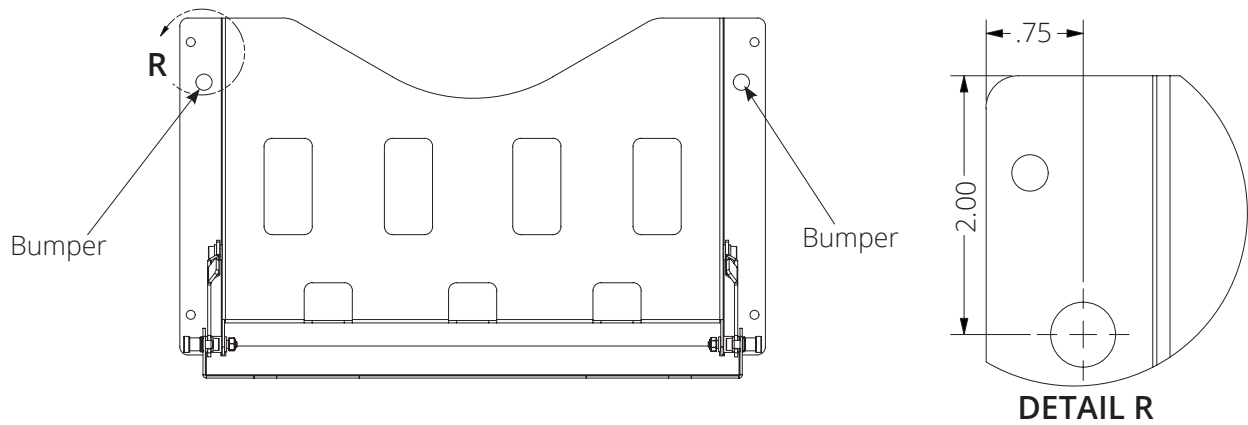

# OPTIONAL ACCESSORIES

## FIBER SPOOLS

Front and rear rails are designed with a Fiber Spool Mounting Pattern (the double hole pattern along the rails).

Part No.	Description	Compatible <b>BOX</b>
BXFS-3K10	Fiber Spool, 3"H x 1.5"W x 3.10"D, Set of 10	All BOX sizes

### To remove fiber spools:

1. Remove (2) #10-32 X 1/2" Phillips machine screws from the rear of the fiber spool. **DETAIL S**

### To reinstall fiber spools:

1. Be sure the fiber spool bracket is inserted through the cable spool.
2. Place the fiber spool along the mounting rail, making sure the holes in the fiber spool bracket align with the fiber spool holes on the mounting rail.
3. Fasten the fiber spool to the mounting rail by using included (2) #10-32 X 1/2" Phillips machine screws. **DETAIL S**

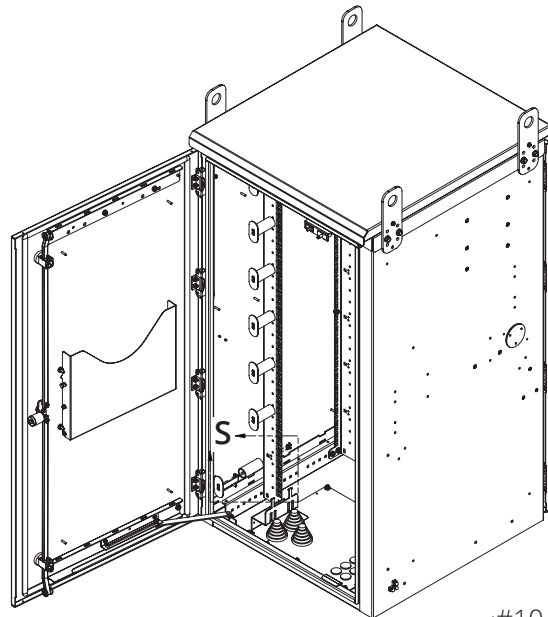

### DETAIL S

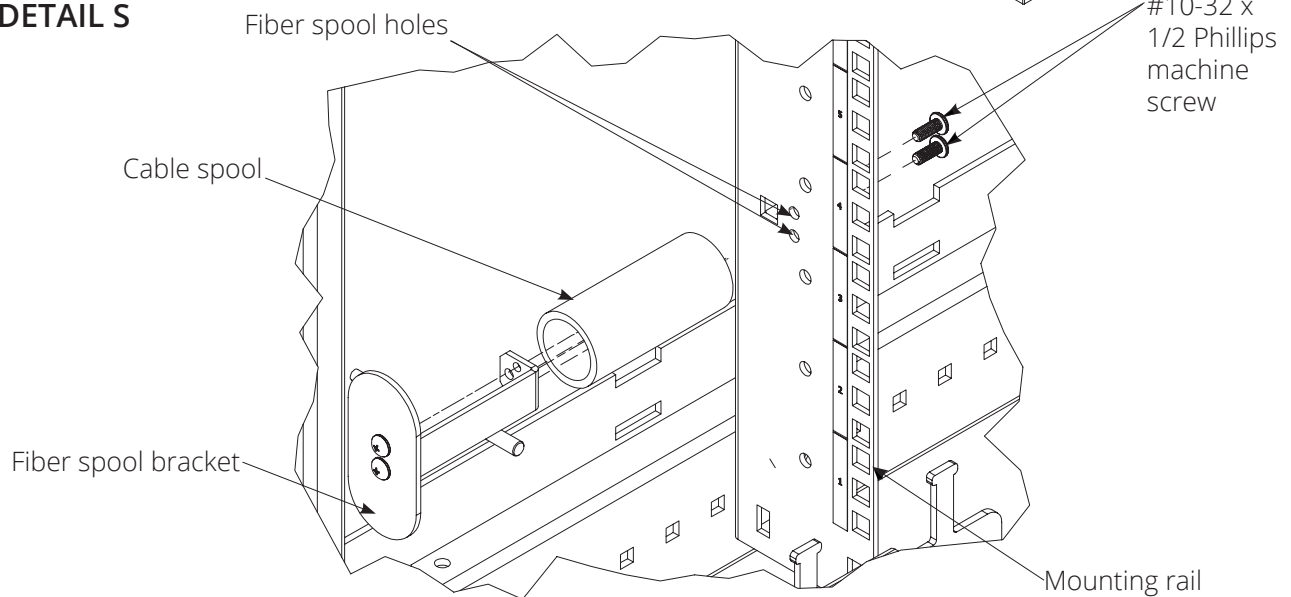

# OPTIONAL ACCESSORIES

## CABLE MANAGEMENT FINGERS

Front and rear rails are designed with a Flexible Mounting Profile (FMP) to accept cable management fingers.

Part No.	Description	Compatible BOX
CM-47	4" x 7 RMU, single finger section	All BOX sizes
CM-77	7" x 7 RMU, single finger section	All BOX sizes
ESC-K6	4" x 7 RMU, set of 6 finger sections	All BOX sizes
ESC-K6-7	7" x 7 RMU, set of 6 finger sections	All BOX sizes
ESC-K8	4" x 7 RMU, set of 8 finger sections	All BOX sizes
ESC-K8-7	7" x 7 RMU, set of 8 finger sections	All BOX sizes

### To install cable management fingers:

**NOTE:** Rails must be recessed 5.75" minimum to accommodate 4" deep fingers and 8.5" minimum to accommodate 7" deep fingers. See "Mounting Rail Adjustment" on page 22.

1. Place cable management finger section along mounting rail and align mounting holes in finger section to FMP holes in mounting rail.
2. Insert included (4) #10-32 X 3/4" Phillips machine screw into (4) mounting holes in the finger section

**NOTE:** There are (6) mounting holes in the finger section. Only (4) are required to be used.

3. Fasten finger section to mounting rail using included (4) #10 keps nuts (3/8" socket) on inserted machine screws. **DETAIL T**
4. Repeat steps 1-3 for remaining finger sections (if applicable).

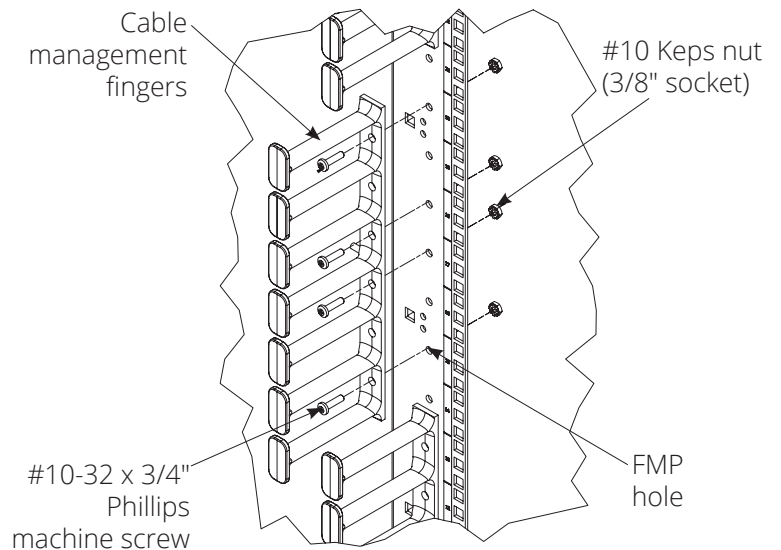
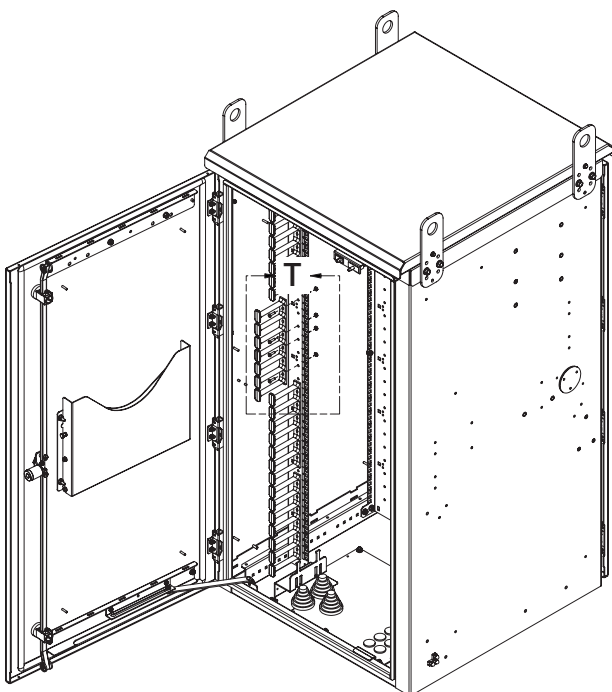

**DETAIL T**

# OPTIONAL ACCESSORIES

## 1/4 TURN "D" RINGS

Front and rear rails are designed with a square hole pattern to accept 1/4 turn "D" rings.

Part No.	Description	Compatible <b>BOX</b>
CM-25	Kit of 10, 1/4 turn "D" rings, 1.5" x 3.5"	All BOX sizes
CM-26	Kit of 10, 1/4 turn "D" rings, 3.5" x 5"	All BOX sizes

### To install 1/4 turn "D" rings:

1. At 45°, insert 1/4 turn "D" ring into square hole along rail.
2. Rotate ring to vertical or horizontal position. **DETAIL U**

**NOTE:** Only 1.5" X 3.5" "D" rings can be installed on the side of rail

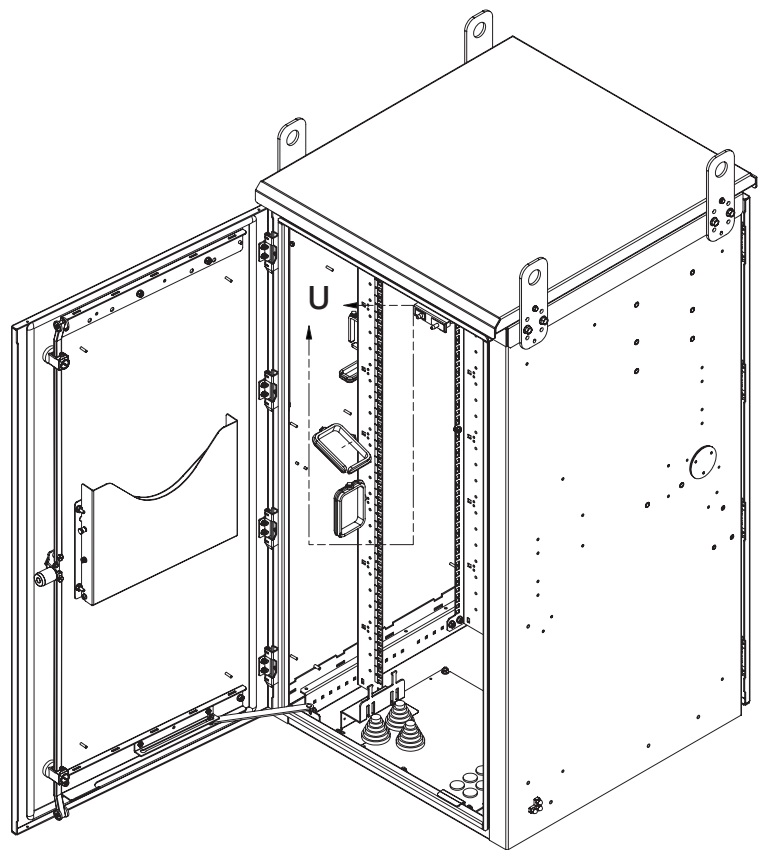

**NOTE:**  
Only 1.5" X 3.5" "D"  
Rings can be  
installed on side  
of rail when used  
in 19" and 23" EIA  
orientation

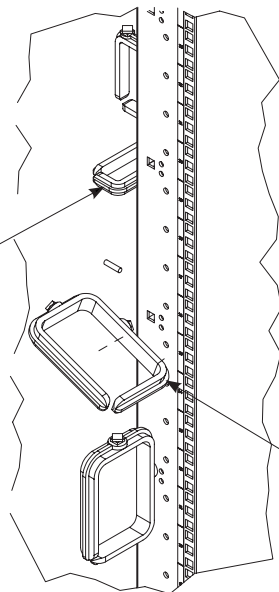

At 45° angle, insert "D" ring into square hole along rail. Rotate ring to a vertical or horizontal position

**DETAIL U**

# OPTIONAL ACCESSORIES

## FRONT-TO-REAR CABLE TROUGH

All mounting rails are designed to accept optional cable management troughs on the 19" or 23" EIA side of the rail.

Part No.	Description	Compatible <b>BOX</b>
BXCMT-32D	Front-to-Rear Cable Trough, 19" between front and rear rail required	All BOX sizes
BXCMT-36D	Front-to-Rear Cable Trough, 23" between front and rear rail required	36"D & 42" BOX sizes
BXCMT-42D	Front-to-Rear Cable Trough, 29" between front and rear rail required	42"D BOX sizes

**NOTE:** Each cable management trough has a maximum fastening length to the mounting rails. See "Mounting Rail Adjustment" (page 22) if additional clearance is needed.

### To install cable management trough:

1. Place cable management trough horizontally along mounting rail outside faces, making sure that square hole in mounting rail is aligned to mounting slot in cable trough.
2. Fasten cable management trough to mounting rails using included (2) 1/4"-20 x 1/2" carriage bolts and (2) 1/4"-20 flange hex nut (7/16" socket). **DETAIL V**

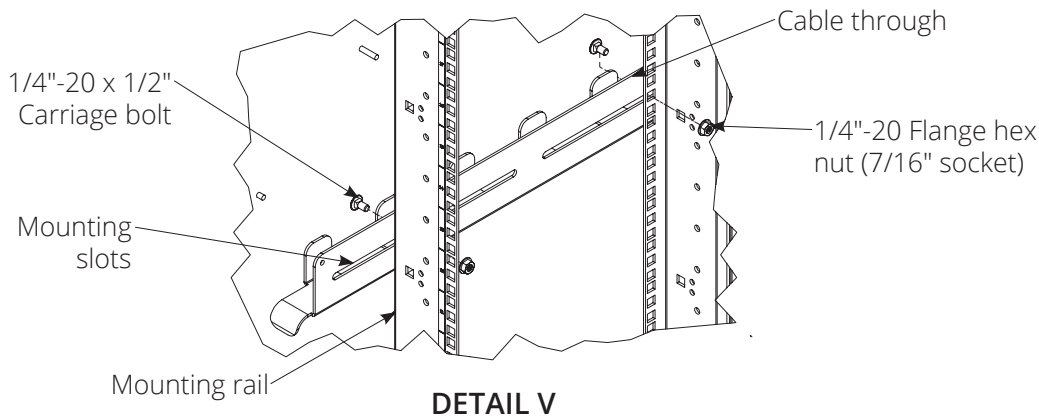
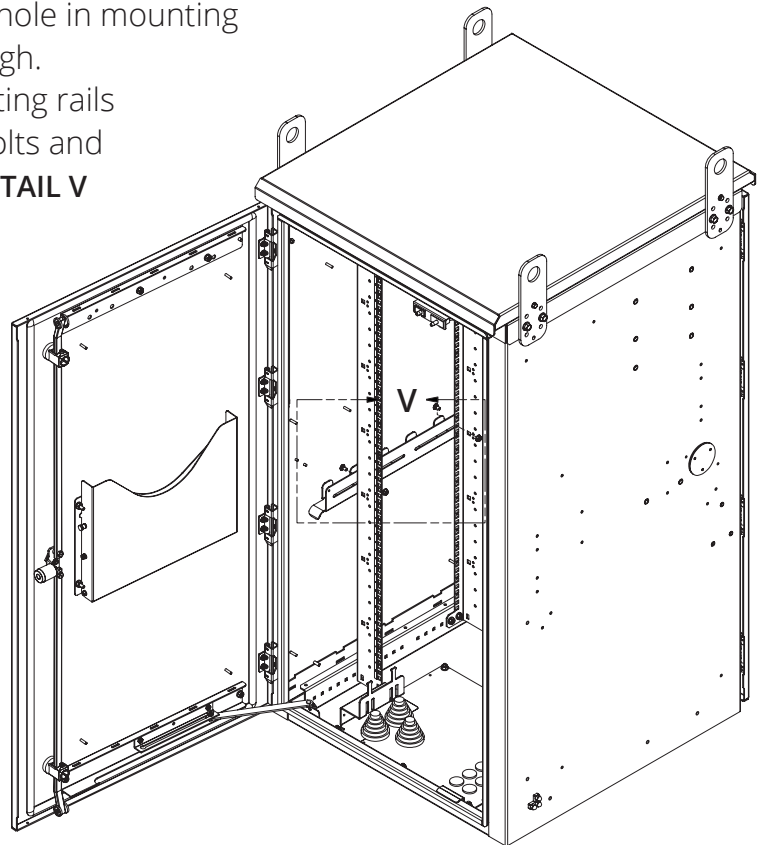

# OPTIONAL ACCESSORIES

## INTERIOR LIGHT KIT

The front and rear of the BOX includes a light mounting bracket to accept an optional LED light.

Part No.	Description	Compatible <b>BOX</b>
BXLED-LED	LED light kit for BOX with 5-15P plug; primary light	All BOX sizes
BXLED-LINK	LED light kit for, links to BXLED-515P; (use when more than 1 light is needed)	All BOX sizes

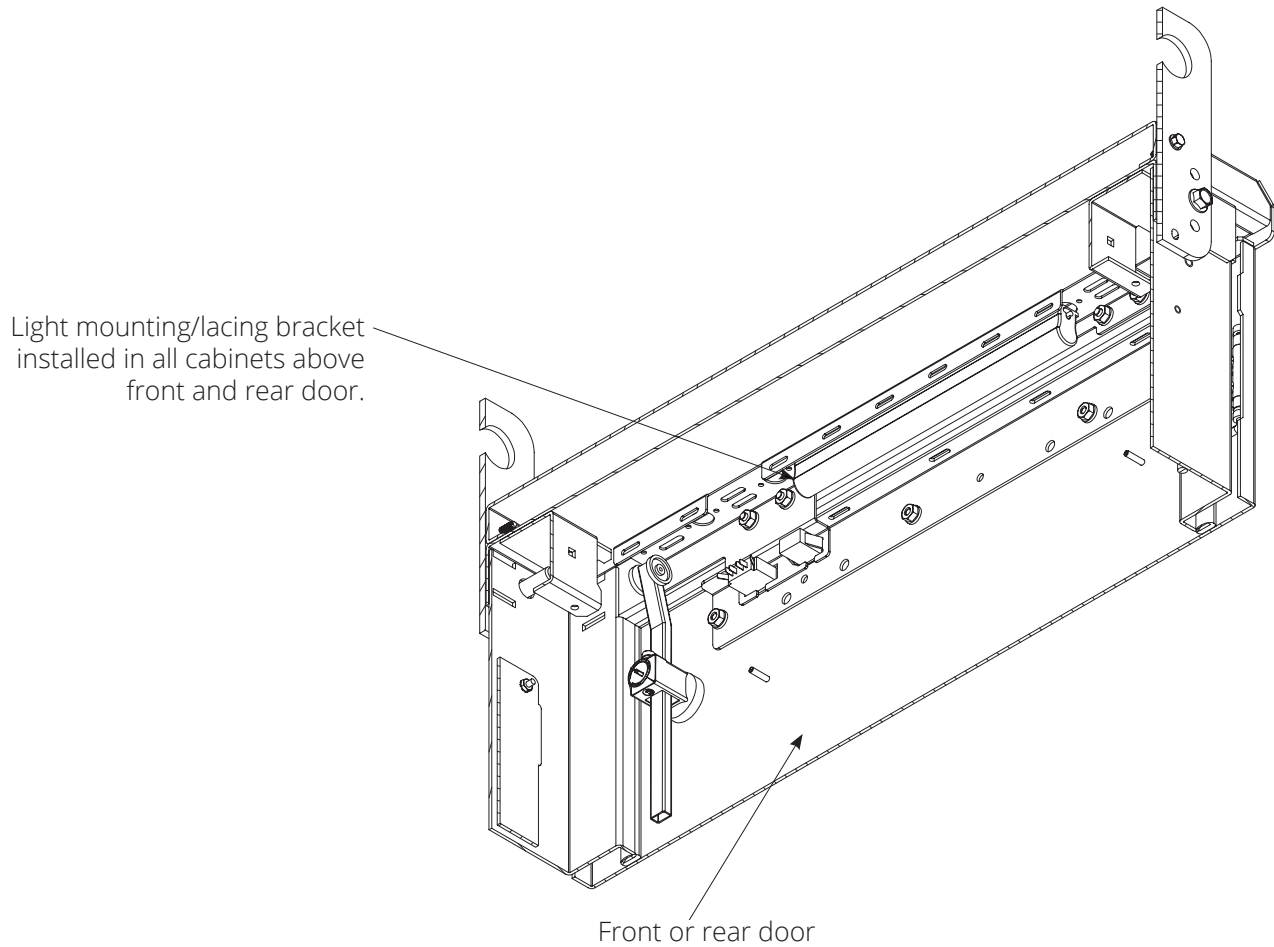

# NOTES



Thank you  
for your  
business!

For repair, troubleshooting, or questions related to information found in this manual, contact Great Lakes Technical Support at 814.734.7303 or at [TechSupport@GreatCabinets.com](mailto:TechSupport@GreatCabinets.com)

FORM MS - 5.02-84, REV 3