



Most Widely Accepted and Trusted

ICC-ES Evaluation Report

ESR-3932

ICC-ES | (800) 423-6587 | (562) 699-0543 | www.icc-es.org

Reissued 07/2018
This report is subject to renewal 07/2019.

DIVISION: 03 00 00—CONCRETE

SECTION: 03 16 00—CONCRETE ANCHORS

DIVISION: 05 00 00—METALS

SECTION: 05 05 19—POST-INSTALLED CONCRETE ANCHORS

REPORT HOLDER:

L.H. DOTTIE COMPANY

EVALUATION SUBJECT:

DOTTIE WEDGE ANCHORS



“2014 Recipient of Prestigious Western States Seismic Policy Council (WSSPC) Award in Excellence”



ICC-ES Evaluation Reports are not to be construed as representing aesthetics or any other attributes not specifically addressed, nor are they to be construed as an endorsement of the subject of the report or a recommendation for its use. There is no warranty by ICC Evaluation Service, LLC, express or implied, as to any finding or other matter in this report, or as to any product covered by the report.



ICC-ES Evaluation Report

ESR-3932

Reissued July 2018

This report is subject to renewal July 2019.

www.icc-es.org | (800) 423-6587 | (562) 699-0543

A Subsidiary of the International Code Council®

DIVISION: 03 00 00—CONCRETE

Section: 03 16 00—Concrete Anchors

DIVISION: 05 00 00—METALS

Section: 05 05 19—Post-Installed Concrete Anchors

REPORT HOLDER:

L.H. DOTTIE COMPANY

EVALUATION SUBJECT:

DOTTIE WEDGE ANCHORS

1.0 EVALUATION SCOPE

Compliance with the following codes:

- 2015, 2012, 2009 and 2006 *International Building Code*® (IBC)
- 2015, 2012, 2009 and 2006 *International Residential Code*® (IRC)

For evaluation for compliance with codes adopted by the Los Angeles Department of Building and Safety (LADBS), see ESR-3932 [LABC and LARC Supplement](#).

Property evaluated:

Structural

2.0 USES

Dottie Wedge Anchors are used as anchorage in normalweight concrete and lightweight concrete having a specified compressive strength, f_c , of 2,500 psi to 8,500 psi (17.2 MPa to 58.6 MPa) to resist static, wind, and earthquake tension and shear loads. The ¼-inch (3.4 mm) nominal diameter anchor is for use in uncracked concrete applications (Seismic Design Categories A and B only); the ⅜-inch (9.5 mm) and ½-inch (12.7 mm) nominal diameter anchors are for use in uncracked and cracked concrete (Seismic Design Categories A through F).

Dottie Wedge Anchors comply with Section 1901.3 of 2015 IBC, Section 1909 of the 2012 IBC, and Section 1912 of the 2009 and 2006 IBC. The anchors are alternatives to cast-in-place anchors described in Section 1908 of the 2012 IBC and Section 1911 of the 2009 and 2006 IBC. The anchors may also be used under the IRC where an engineered design is submitted in accordance with Section R301.1.3.

3.0 DESCRIPTION

3.1 Dottie Wedge Anchors:

The Dottie Wedge Anchors are torque-controlled expansion anchors. The anchors consist of a stud, nut,

washer, expander collar, expansion wedge (clip), and mandrel, as illustrated in Figure 1 of this report. The stud for all sizes is manufactured from cold-drawn carbon steel meeting the requirements of Chinese Standard Q/HGJ2184, Grade SWRCH35K or equivalent with a minimum ultimate tensile strength of 79,750 psi (550 MPa) and is partially threaded with one end terminating in a flared mandrel. The expander collar and expansion wedge (clip) are manufactured from hot-rolled carbon steel meeting the requirements of Chinese Standard GB/T8749 with a minimum ultimate tensile strength of 79,750 psi (550 MPa) and are formed around the stud and mandrel so they are able to move freely. All components, including nuts and washers, are coated in accordance with ASTM B633 Classification SC1, Type III. Installation information and dimensions are set forth in Section 4.3, Figure 2, and Table 1 and Table 2 of this report.

3.2 Concrete:

Normalweight and lightweight concrete must comply with Sections 1903 and 1905 of the IBC, as applicable.

4.0 DESIGN AND INSTALLATION

4.1 Strength Design:

4.1.1 General: Design strength of anchors complying with 2015 IBC, as well as Section R301.1.3 of the 2015 IRC must be determined in accordance with ACI 318-14 and this report.

Design strength of anchors complying with the 2012 IBC, as well as Section R301.1.3 of the 2012 IRC, must be determined in accordance with ACI 318-11 Appendix D and this report.

Design strength of anchors complying with the 2009 IBC, as well as Section R301.1.3 of the 2009 IRC, must be determined in accordance with ACI 318-08 Appendix D and this report.

Design strength of anchors complying with the 2006 IBC and Section R301.1.3 of the 2006 IRC must be determined in accordance with ACI 318-05 Appendix D and this report.

The strength design of anchors must comply with ACI 318-14 Section 17.3.1 or ACI 318 (-11, -08, -05) Appendix D Section D.4.1, as applicable. Strength reduction factors, ϕ , as given in ACI 318-14 Section 17.3.3 or ACI 318-11 Appendix D Section D.4.3 or ACI 318 (-08, -05) D.4.4, as applicable, must be used for load combinations calculated in accordance with Section 1605.2 of the IBC, Section 5.3 of ACI 318-14 and Section 9.2 of ACI 318 (-11, -08, -05), as applicable. Strength reduction factors, ϕ , given in ACI 318-11 Appendix D Section D.4.4 or ACI 318 (-08, -05) D.4.5 must be used for load combinations calculated in accordance with ACI 318 (-11, -08, -05), Appendix C. The

value of f'_c , used in calculations must be limited to a maximum of 8,000 psi (55.2 MPa), in accordance with ACI 318-14 Section 17.2.7 or ACI 318-11 Appendix D Section D.3.7, as applicable.

4.1.2 Requirements for Static Steel Strength in Tension, N_{sa} : The nominal steel strength of a single anchor in tension, N_{sa} , calculated in accordance with ACI 318-14 Section 17.4.1.2 or ACI 318 (-11, -08, -05) Appendix D Section D.5.1.2, as applicable, must be calculated based on the information given in Table 1 and must be used for design. The strength reduction factor, ϕ , corresponding to a ductile steel element may be used.

4.1.3 Requirements for Static Concrete Breakout Strength in Tension, N_{cb} or N_{cbg} : The nominal concrete breakout strength of a single anchor or a group of anchors in tension, N_{cb} and N_{cbg} , respectively, must be calculated in accordance with ACI 318-14 Section 17.4.2 or ACI 318 (-11, -08, -05) Appendix D Section D.5.2, as applicable, with modifications as described in this section. The basic concrete breakout strength in tension, N_b , must be calculated in accordance with ACI 318-14 Section 17.4.2.2 or ACI 318 (-11, -08, -05) Appendix D Section D.5.2.2, as applicable, using the values of h_{ef} and k_{cr} as given in Table 1 of this report. The nominal concrete breakout strength in tension in regions of concrete where analysis indicates no cracking at service loads in accordance with ACI 318-14 Section 17.4.2.6 or ACI 318 (-11, -08, -05) Appendix D Section D.5.2.6, as applicable, must be calculated with the value of k_{uncr} given in Table 1 of this report, and with $\psi_{c,N} = 1.0$. The value of f'_c used in the calculations must be limited to 8,000 psi (55.2 MPa), in accordance with ACI 318-14 Section 17.2.7 or ACI 318-11 D.3.7, as applicable.

4.1.4 Requirements for Pullout Strength in Tension, N_{pn} : The nominal pullout strength of a single anchor in tension in accordance with ACI 318-14 Section 17.4.3 or ACI 318 (-11, -08, -05) Appendix D Section D.5.3, as applicable, in cracked and uncracked concrete, $N_{p,cr}$ and $N_{p,uncr}$ respectively, is given in Table 1. In lieu of ACI 318-14 Section 17.4.3.6 or ACI 318 (-11, -08, -05) Appendix D Section D.5.3.6, as applicable, $\psi_{c,P} = 1.0$ for all design cases. In accordance with ACI 318-14 Section 17.4.3 or ACI 318 (-11, -08, -05) Appendix D Section D.5.3, as applicable, the nominal pullout strength in cracked and uncracked concrete may be calculated in accordance with the Eq-1 or Eq-2 respectively:

$$N_{p,f'_c} = N_{p,cr} \sqrt{\frac{f'_c}{2,500}} \quad (\text{lb, psi}) \quad (\text{Eq-1})$$

$$N_{p,f'_c} = N_{p,cr} \sqrt{\frac{f'_c}{17.2}} \quad (\text{N, MPa})$$

$$N_{p,f'_c} = N_{p,uncr} \sqrt{\frac{f'_c}{2,500}} \quad (\text{lb, psi}) \quad (\text{Eq-2})$$

$$N_{p,f'_c} = N_{p,uncr} \sqrt{\frac{f'_c}{17.2}} \quad (\text{N, MPa})$$

Where values for $N_{p,cr}$ and $N_{p,uncr}$ are not provided in Table 1, the pullout strength in tension need not be evaluated.

4.1.5 Requirements for Static Steel Strength in shear, V_{sa} : The nominal steel strength in shear, V_{sa} , of a single anchor in accordance with ACI 318-14 Section 17.5.1.2 or ACI 318 (-11, -08, -05) Appendix D Section D.6.1.2, as applicable, is given in Table 1 of this report, and must be used in lieu of values derived by calculation from ACI 318-14 Eq. 17.5.1.2a or ACI 318-11 Eq. D-29, as

applicable. The strength reduction factor, ϕ , corresponding to a ductile steel element may be used.

4.1.6 Requirements for Static Concrete Breakout Strength in Shear, V_{cb} or V_{cbg} : The nominal concrete breakout strength of a single anchor or group of anchors in shear, V_{cb} or V_{cbg} , respectively, must be calculated in accordance with ACI 318-14 Section 17.5.2 or ACI 318 (-11, -08, -05) Appendix D Section D.6.2, as applicable with modifications as described in this section. The basic concrete breakout strength in shear, V_b , must be calculated in accordance with ACI 318-14 Section 17.5.2.2 or ACI 318 (-11, -08, -05) Appendix D Section D.6.2.2, as applicable, using the values of l_e and d_a according to Table 1 of this report. The value of f'_c must be limited to a maximum of 8,000 psi (55.2 MPa) in accordance with ACI 318-14 Section 17.2.7 or ACI 318-11 Appendix D Section D.3.7, as applicable.

4.1.7 Requirements for Static Concrete Pryout Strength of Anchor in Shear, V_{cp} or V_{cpg} : The nominal concrete pryout strength of a single anchor or group of anchors, V_{cp} or V_{cpg} , respectively, must be calculated in accordance with ACI 318-14 Section 17.5.3 or ACI 318 (-11, -08, -05) Appendix D Section D.6.3, as applicable, based on the value of k_{cp} provided in Table 1 and the value of N_{cb} or N_{cbg} as calculated in Section 4.1.3 of this report.

4.1.8 Requirements for Seismic Design:

4.1.8.1 General: For load combinations including seismic, the design must be performed in accordance with ACI 318-14 Section 17.2.3 or ACI 318-11 Appendix D Section D.3.3, as applicable. Modifications to ACI 318-14 Section 17.2.3 shall be applied under Section 1905.1.8 of the 2015 IBC. For the 2012 IBC, Section 1905.1.9 shall be omitted. Modifications to ACI 318-08 and 318-05 Appendix D Section D.3.3 shall be applied under Section 1908.1.9 of the 2009 IBC, Section 1908.1.16 of the 2006 IBC, respectively.

The 1/4-inch (3.4 mm) anchors are for use in uncracked concrete applications (Seismic Design Categories A and B only); the 3/8-inch (9.5 mm) and 1/2-inch (12.7 mm) anchors are for use in uncracked and cracked concrete (Seismic Design Categories A through F). The anchors comply with ACI 318-14 2.3 or ACI 318-11 D.1, as applicable, as ductile steel elements. The anchors must be designed in accordance with ACI 318-14 Section 17.2.3.4, 17.2.3.5, or 17.2.3.6 or ACI 318-11 Appendix D Section D.3.3.4, D.3.3.5, or D.3.3.6 or ACI 318-08 Appendix D Section D.3.3.4, D.3.3.5 or D.3.3.6, or ACI 318-05 Appendix D Section D.3.3.4 or D.3.3.5, as applicable, with the modifications noted above.

4.1.8.2 Seismic Tension: The nominal steel strength and concrete breakout strength in tension must be calculated in accordance with ACI 318-14 Section 17.4.1 and 17.4.2 or ACI 318-11 Appendix D Section D.5.1 and D.5.2, as applicable, as described in Sections 4.1.2 and 4.1.3 of this report. In accordance with ACI 318-14 Section 17.4.3.2 or ACI 318-11 Appendix D Section D.5.3.2, as applicable, the appropriate value for nominal pullout strength in tension for seismic loads, $N_{p,eq}$ described in Table 1 of this report must be used in lieu of N_p . The values of $N_{p,eq}$ can be adjusted for concrete strength according to Section 4.1.4 Eq-1 of this report.

4.1.8.3 Seismic Shear: The nominal concrete breakout and concrete pryout strength in shear must be calculated in accordance with ACI 318-14 Section 17.5.2 and 17.5.3 or ACI 318-11 Appendix D Section D.6.2 and D.6.3, as applicable, as described in Sections 4.1.6 and 4.1.7 of this report. In accordance with ACI 318-14 Section 17.5.1.2 or

ACI 318-11 Appendix D Section D.6.1.2, as applicable, the appropriate value for nominal steel strength in shear for seismic loads, $V_{sa,eq}$ described in Table 1 of this report, must be used in lieu of V_{sa} .

4.1.9 Requirements for Interaction of Tensile and Shear Forces: For loadings that include combined tensile and shear forces, the design must be determined in accordance with ACI 318-14 Section 17.6 or ACI 318 (-11, -08, -05) Appendix D Section D.7, as applicable.

4.1.10 Requirements for Critical Edge Distance: In applications where the installed edge distance $c < c_{ac}$ and supplemental reinforcement to control splitting of the concrete is not present, the concrete breakout strength for the anchors loaded in tension for uncracked concrete, calculated in accordance with ACI 318-14 Section 17.4.2 or ACI 318 (-11, -08, -05) Appendix D Section D.5.2, as applicable, must be further multiplied by the factor $\Psi_{CP,N}$ as given by the following equation:

$$\Psi_{CP,N} = \frac{c}{c_{ac}}$$

where the factor $\Psi_{CP,N}$ need not be taken as less than $1.5h_{ef}/c_{ac}$.

For all other cases, $\Psi_{CP,N} = 1.0$. In lieu of ACI 318-14 Section 17.7.6 or ACI 318-11 Appendix D Section D.8.6, as applicable, values of c_{ac} provided in Table 1 of this report must be used. In all cases, c must not be less than c_{min} described in Table 1 of this report.

4.1.11 Requirements for Minimum Member Thickness, Minimum Anchor Spacing and Minimum Edge Distance: In lieu of using ACI 318-14 Section 17.7.1 and 17.7.3 or ACI 318 (-11, -08, -05) Appendix D Section D.8.1 and D.8.3, as applicable, values of s_{min} and c_{min} as given in Table 1 of this report must be used. In lieu of using ACI 318-14 Section 17.7.5 or ACI 318 (-11 -08, -05) Appendix D Section D.8.5, as applicable, minimum member thicknesses h_{min} as given in Table 1 of this report must be used.

4.1.12 Lightweight Concrete: For the use of anchors in lightweight concrete, the modification factor λ_a equal to 0.8λ is applied to all values of $\sqrt{f'_c}$ affecting N_n and V_n .

For ACI 318-14 (2015 IBC), ACI 318-11 (2012 IBC) and ACI 318-08 (2009 IBC), λ shall be determined in accordance with the corresponding version of ACI 318.

For ACI 318-05 (2006 IBC), λ shall be taken as 0.75 for all lightweight concrete and 0.85 for sand-lightweight concrete. Linear interpolation shall be permitted if partial sand replacement is used. In addition, the pullout strengths $N_{p,cr}$, $N_{p,uncr}$, and N_{eq} shall be multiplied by the modification factor, λ_a , as applicable.

4.2 Allowable Stress Design (ASD):

4.2.1 General: Design values for use with allowable stress design load combinations, calculated in accordance with Section 1605.3 of the IBC, must be established in accordance with the following equations:

$$T_{allowable,ASD} = \frac{\phi N_n}{\alpha}$$

$$V_{allowable,ASD} = \frac{\phi V_n}{\alpha}$$

where:

$T_{allowable,ASD}$ = Allowable tension load (lbf or kN)

$V_{allowable,ASD}$ = Allowable shear load (lbf or kN)

ϕN_n = Lowest design strength of an anchor or anchor group in tension as determined in accordance with ACI 318-14 Chapter 17 and 2015 IBC Section 1905.1.8, ACI 318-11 Appendix D, ACI 318-08 Appendix D and 2009 IBC Section 1908.1.9, ACI 318-05 Appendix D and 2006 IBC Section 1908.1.16, and Section 4.1 of this report as applicable. (lbf or kN).

ϕV_n = Lowest design strength of an anchor or anchor group in shear as determined in accordance with ACI 318-14 Chapter 17 and 2015 IBC Section 1905.1.8, ACI 318-11 Appendix D, ACI 318-08 Appendix D and 2009 IBC Section 1908.1.9, ACI 318-05 Appendix D and 2006 IBC Section 1908.1.16, and Section 4.1 of this report as applicable. (lbf or kN).

α = Conversion factor calculated as a weighted average of the load factors for the controlling load combination. In addition, α must include all applicable factors to account for nonductile failure modes and required over-strength.

The requirements for member thickness, edge distance and spacing, described in this report, must apply. An example of allowable stress design values for illustrative purposes is provided in Table 3 of this report.

4.2.2 Interaction of Tensile and Shear Forces: The interaction must be calculated and consistent with ACI 318-14 Section 17.6 or ACI 318 (-11, -08, -05) Appendix D Section D.7, as applicable, as follows:

For shear loads $V_{applied} \leq 0.2V_{allowable,ASD}$, the full allowable load in tension must be permitted.

For tension loads $T_{applied} \leq 0.2T_{allowable,ASD}$, the full allowable load in shear must be permitted.

For all other cases the following equation applies:

$$\frac{T_{applied}}{T_{allowable,ASD}} + \frac{V_{applied}}{V_{allowable,ASD}} \leq 1.2$$

4.3 Installation:

Embedment, spacing, edge distance, and concrete requirements must comply with Table 1 and Figure 2.

Anchor locations must comply with this report and the plans and specifications approved by the code official. Dottie Wedge Anchors must be installed in accordance with the manufacturer's published instructions and this report (see installation instructions at the end of this report). In case of conflict, this report governs.

4.4 Special Inspection:

Periodic special inspection is required in accordance with Section 1705.1.1 and Table 1705.3 of the 2015 IBC and 2012 IBC, Section 1704.15 and Table 1704.4 of the 2009 IBC, or Section 1704.13 of the 2006 IBC, as applicable. The special inspector must make periodic inspections during anchor installation to verify anchor type, anchor dimensions, concrete type, concrete compressive strength, drill bit type, hole dimensions, hole cleaning procedure, concrete member thickness, anchor embedment, anchor spacing, edge distances, tightening torque and adherence to the manufacturer's printed installation instructions. The special inspector must be present as often as required in accordance with the "statement of special inspection."

5.0 CONDITIONS OF USE

The Dottie Wedge Anchors described in this report comply with, or are suitable alternatives to what is specified in, those codes listed in Section 1.0 of this report, subject to the following conditions:

- 5.1 The anchors are installed in accordance with the manufacturer's published instructions and this report. In case of a conflict, this report governs.
- 5.2 The anchors are installed in normalweight concrete or lightweight concrete having a specified compressive strength $f_c = 2,500$ psi to 8,500 psi (17.2 MPa to 58.6 MPa).
- 5.3 Anchor sizes, dimensions, minimum embedment depths, and other installation parameters are as set forth in this report.
- 5.4 The values of f_c used for calculation purposes must not exceed 8,000 psi (55.1 MPa).
- 5.5 The concrete shall have attained its minimum design strength prior to installation of the anchors.
- 5.6 Strength design values must be established in accordance with Section 4.1 of this report.
- 5.7 Allowable stress design values must be established in accordance with Section 4.2.
- 5.8 Anchor spacing(s) and edge distance(s) as well as minimum member thickness must comply with Table 1.
- 5.9 Prior to installation, calculations and details demonstrating compliance with this report must be submitted to the code official. The calculations and details must be prepared by a registered design professional where required by the statutes of the jurisdiction in which the project is to be constructed.
- 5.10 Since an ICC-ES acceptance criteria for evaluating data to determine the performance of anchors subjected to fatigue or shock loading is unavailable at this time, the use of these anchors under such conditions is beyond the scope of this report.
- 5.11 The use of the ¼-inch (3.4 mm) Dottie Wedge Anchors is limited to installation in uncracked normalweight or lightweight concrete. The ⅜-inch (9.5 mm) and ½-inch (12.7 mm) anchors may be installed in cracked or uncracked normalweight or lightweight concrete.
- 5.12 The ¼-inch (3.4 mm) anchors may be used to resist short-term loading due to wind or seismic forces limited to structures assigned to Seismic Design Categories A and B under the IBC, subject to the conditions of this report.
- 5.13 Where not otherwise prohibited in the code, Dottie Wedge Anchors are permitted for use with fire-resistance-rated construction provided that at least one of the following conditions is fulfilled:
 - The anchors are used to resist wind forces only.
 - Anchors that support a fire-resistance-rated envelope or a fire-resistance-rated membrane are protected by approved fire-resistance-rated materials, or have been evaluated for resistance to fire exposure in accordance with recognized standards.
 - Anchors are used to support nonstructural elements.
- 5.14 Use of the anchors is limited to dry, interior locations.
- 5.15 Special inspection must be provided as set forth in Section 4.4 of this report.
- 5.16 Dottie Wedge are produced in Yuyao, China, under a quality-control program with inspections by ICC-ES.

6.0 EVIDENCE SUBMITTED

Data in accordance with the ICC-ES Acceptance Criteria for Mechanical Anchors in Concrete Elements (AC193), dated October 2015; and quality-control documentation.

7.0 IDENTIFICATION

- 7.1 Anchors are packaged in containers labeled with the company logo and name (L.H. Dottie Company), product name, anchor size and length, catalog number and the evaluation report number (ESR-3932).
- 7.2 The report holder's contact information is the following:

L.H. DOTTIE COMPANY
6131 SOUTH GARFIELD AVENUE
COMMERCE, CALIFORNIA 90040
(323) 725-1000
www.lhdottie.com
lane@lhdottie.com

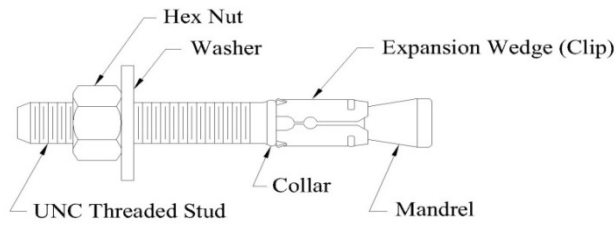

FIGURE 1—DOTTIE WEDGE ANCHOR COMPONENTS

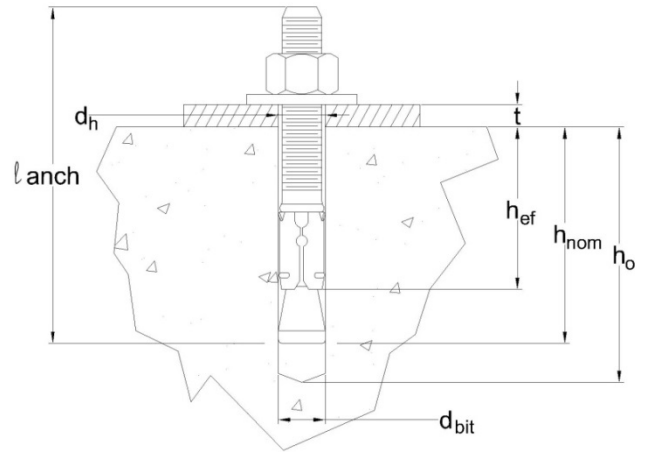

FIGURE 2—DOTTIE WEDGE ANCHOR INSTALLATION

TABLE 1—DATA FOR DOTTIE WEDGE ANCHORS FOR USE IN CONCRETE ^{1,2}

CHARACTERISTIC	SYMBOL	UNITS	Nominal Anchor Diameter		
			1/4 inch	3/8 inch	1/2 inch
Installation Information					
Anchor diameter	$d_a(d_o)^3$	in.	1/4	3/8	1/2
Minimum diameter of hole clearance in fixture	d_h	in.	5/16	7/16	9/16
Nominal drill bit diameter	d_{bit}	in.	1/4	3/8	1/2
Minimum nominal embedment depth	h_{nom}	in.	1 3/4	2 1/2	2 1/2
Minimum effective embedment depth	h_{ef}	in.	1 1/2	2 1/4	2 1/4
Minimum hole depth	h_o	in.	2	2 3/4	2 3/4
Installation torque	T_{inst}	ft-lb	8	25	35
Minimum edge distance	c_{min}	in.	1 3/4	3	6
Minimum spacing	s_{min}	in.	3	5	6
Minimum concrete thickness	h_{min}	in.	4	4	6
Critical edge distance	c_{ac}	in.	3	6	8
Anchor Design Data					
Category number	1, 2 or 3	–	1	1	1
Yield strength of anchor steel	f_{ya}	lb/in ²	91,700	91,200	88,600
Ultimate strength of anchor steel	f_{uta}	lb/in ²	103,100	102,600	99,700
Tension					
Effective tensile stress area (neck)	$A_{se,N}$	in ²	0.022	0.053	0.101
Steel strength in tension	N_{sa}	lb.	2270	5440	10070
Reduction factor for steel failure modes ⁵	ϕ	–	0.75		
Effectiveness factor for concrete breakout, cracked	k_{cr}	–	–	17	17
Effectiveness factor for concrete breakout, uncracked	k_{unscr}	–	24	24	24
Reduction factor for concrete breakout ⁶	ϕ	-	0.65 (Condition B)		
Characteristic pull-out resistance, uncracked concrete ⁴	$N_{p,unscr}$	lb.	1190	2940	N/A ⁸
Characteristic pull-out resistance, cracked concrete	$N_{p,cr}$	lb.	-	1330	1080
Characteristic pull-out resistance, seismic loads	$N_{p,eq}$	lb.	-	1330	1080
Reduction factor for pull-out ⁶	ϕ	-	0.65 (Condition B)		
Axial stiffness in service load range	β	lb/in	147,100	36,500	40,300
Shear					
Effective shear stress area (threads)	$A_{se,V}$	in ²	0.022	0.053	0.101
Load-bearing length of anchor	ℓ_e	in.	1 1/2	2 1/4	2 1/4
Reduction factor for concrete breakout or pryout ⁶	ϕ	-	0.70 (Condition B)		
Coefficient for pryout strength	k_{cp}	-	1.0		
Steel strength in shear, non-seismic applications ⁷	V_{sa}	lb.	1050	1830	3610
Steel strength in shear, seismic applications ⁷	$V_{sa,eq}$	lb.	-	1650	3250
Reduction factor for steel failure ⁵	ϕ	-	0.065		

For SI: 1 in = 25.4 mm, 1 in² = 6.451x10⁻⁴ m², 1 ft-lb = 1.356 Nm, 1 lb/in² = 6.895 Pa.

¹ The information presented in this table must be used in conjunction with the design criteria of ACI 318-14 Chapter 17 or ACI 318 Appendix D, as applicable.

² Installation must comply with the manufacturer's published installation instructions

³ The notation in parentheses is for the 2006 IBC.

⁴ See Section 4.1.4 of this report.

⁵ Anchors are considered to be manufactured using ductile steel in accordance with ACI 318-14 2.3 or ACI 318-11 D.1. Strength reduction factors are for use with the load combinations of ACI 318-14 Section 5.3, ACI 318 (-11, -08, -05) Section 9.2 or IBC Section 1605.2, as applicable.

⁶ Condition B applies where supplementary reinforcement in conformance with ACI 318-14 17.3.3 or ACI 318 (-11, 08, 05) D.4.3 or ACI 318 (-08, -05) D.4.4 is not provided, or where pull-out or pry-out strength governs. For cases where supplementary reinforcement can be verified, the strength reduction factors associated with Condition A may be used. Strength reduction factors are for use with the load combinations of ACI 318-14 Section 5.3, ACI 318-11 Section 9.2 or IBC Section 1605.2.

⁷ Tabulated values must be used for design since these values are lower than those calculated with ACI 318-14 Eq. (17.5.1.2b), ACI 318-11 Eq. (D-29) or ACI 318-08 and ACI 318-05 Eq. (D-20), as applicable.

⁸ N/A denotes that pullout resistance is not applicable and does not need to be considered

TABLE 2—DOTTIE WEDGE ANCHOR LENGTH CODE IDENTIFICATION SYSTEM

Length ID marking on threaded stud head		A	B	C	D	E	F	G	H	I	J	K	L	M	N	O	P	Q	R	S
Overall anchor length, l_{anch} (inches)	From	1 1/2	2	2 1/2	3	3 1/2	4	4 1/2	5	5 1/2	6	6 1/2	7	7 1/2	8	8 1/2	9	9 1/2	10	11
	Up to but not including	2	2 1/2	3	3 1/2	4	4 1/2	5	5 1/2	6	6 1/2	7	7 1/2	8	8 1/2	9	9 1/2	10	11	12

For SI: 1 inch = 25.4 mm.

INSTALLATION INSTRUCTIONS

1. Use a rotary hammer drill in the percussion mode with the correct size carbide drill bit meeting the requirements of ANSI Standard B212-15 to drill the hole perpendicular to the concrete surface and to the required depth.
2. Use a hand pump, compressed air or vacuum to remove debris and dust from the drilling operation.
3. If installation is through a fixture, position the fixture over the hole and install the anchor through the hole in the fixture. Using a hammer drive the anchor into the hole insuring that it is installed to the minimum required embedment depth, h_{nom} .
4. Install the washer and nut on the projecting thread and tighten the nut to the required installation torque value, T_{inst} , using a torque wrench.

TABLE 3—EXAMPLE OF ALLOWABLE STRESS DESIGN VALUES FOR ILLUSTRATIVE PURPOSES ^{1, 2, 3, 4, 5, 6, 7, 8}

Nominal Anchor Diameter, d_a (d_o) (in.)	Nominal Embedment Depth, h_{nom} (in.)	Effective Embedment Depth, h_{ef} (in.)	Allowable Tension Load, (lbs.)
1/4	1 3/4	1 1/2	520
3/8	2 1/2	2 1/4	1290
1/2	2 1/2	2 1/4	1780

¹ Single anchor with static tension only.

² Concrete determined to remain uncracked for the life of the anchorage

³ Load combinations from ACI 318-14 Section 5.3 or ACI 318 (-11, -08, 05) Section. 9.2, as applicable and strength reduction factors from ACI 318-14 17.3.3(c) or ACI 318-11 D.4.3(c) Condition B (supplementary reinforcement not provided).

⁴ Controlling load combination 30% dead and 70% live loads, 1.2D+1.6L.

⁵ Calculation of weighted average $\alpha = 1.2(0.3) + 1.6(0.7) = 1.48$.

⁶ Normalweight concrete with $f'_c = 2,500$ psi.

⁷ $C_{a1} = C_{a2} \geq C_{ac}$.

⁸ $h \geq h_{min}$.

ICC-ES Evaluation Report

ESR-3932 LABC and LARC Supplement

Reissued July 2018

This report is subject to renewal July 2019.

www.icc-es.org | (800) 423-6587 | (562) 699-0543 A Subsidiary of the International Code Council®

DIVISION: 03 00 00—CONCRETE
Section: 03 16 00—Concrete Anchors

DIVISION: 05 00 00—METALS
Section: 05 05 19—Post-Installed Concrete Anchors

REPORT HOLDER:

L.H. DOTTIE COMPANY

EVALUATION SUBJECT:

DOTTIE WEDGE ANCHORS

1.0 REPORT PURPOSE AND SCOPE

Purpose:

The purpose of this evaluation report supplement is to indicate that Dottie Wedge Anchors, described in ICC-ES master evaluation report [ESR-3932](#), have also been evaluated for compliance with the codes noted below as adopted by the Los Angeles Department of Building and Safety (LADBS).

Applicable code editions:

- 2017 *City of Los Angeles Building Code* (LABC)
- 2017 *City of Los Angeles Residential Code* (LARC)

2.0 CONCLUSIONS

The Dottie Wedge Anchors, described in Sections 2.0 through 7.0 of the master evaluation report [ESR-3932](#), comply with LABC Chapter 19, and LARC, and are subjected to the conditions of use described in this supplement.

3.0 CONDITIONS OF USE

The Dottie Wedge Anchors described in this evaluation report must comply with all of the following conditions:

- All applicable sections in the master evaluation report [ESR-3932](#).
- The design, installation, conditions of use and identification of the anchors are in accordance with the 2015 *International Building Code*® (2015 IBC) provisions noted in the master evaluation report [ESR-3932](#).
- The design, installation and inspection are in accordance with additional requirements of LABC Chapters 16 and 17, as applicable.
- Under the LARC, an engineered design in accordance with LARC Section R301.1.3 must be submitted.
- The allowable and strength design values listed in the master evaluation report and tables are for the connection of the anchors to the concrete. The connection between the anchors and the connected members must be checked for capacity (which may govern).

This supplement expires concurrently with the master report, reissued July 2018.

ICC-ES Evaluation Report

ESR-3932 FBC Supplement

Reissued July 2018

This report is subject to renewal July 2019.

www.icc-es.org | (800) 423-6587 | (562) 699-0543

A Subsidiary of the International Code Council®

DIVISION: 03 00 00—CONCRETE

Section: 03 16 00—Concrete Anchors

DIVISION: 05 00 00—METALS

Section: 05 05 19—Post-Installed Concrete Anchors

REPORT HOLDER:

L.H. DOTTIE COMPANY

EVALUATION SUBJECT:

DOTTIE WEDGE ANCHORS

1.0 REPORT PURPOSE AND SCOPE

Purpose:

The purpose of this evaluation report supplement is to indicate that the Dottie Wedge Anchors, recognized in ICC-ES master evaluation report ESR-3932, have also been evaluated for compliance with the codes noted below.

Applicable code editions:

- 2014 *Florida Building Code—Building*
- 2014 *Florida Building Code—Residential*

2.0 CONCLUSIONS

The Dottie Wedge Anchors in uncracked and cracked concrete, described in master evaluation report ESR-3932, comply with the 2014 *Florida Building Code—Building* and the 2014 *Florida Building Code—Residential*, when designed and installed in accordance with the 2012 *International Building Code*® provisions noted in the master report, and under the following conditions:

- Design wind loads must be based on Section 1609 of the 2014 *Florida Building Code—Building* or Section 301.2.1.1 of the 2014 *Florida Building Code—Residential*, as applicable.
- Load combinations must be in accordance with Section 1605.2 or Section 1605.3 of the 2014 *Florida Building Code—Building*, as applicable.

Use of the Dottie Wedge Anchors in uncracked and cracked concrete, for compliance with the High-Velocity Hurricane Zone Provisions of the 2014 *Florida Building Code—Building* and 2014 *Florida Building Code—Residential*, has not been evaluated and is outside the scope of this supplement.

For products falling under Florida Rule 9N-3, verification that the report holder's quality-assurance program is audited by a quality-assurance entity approved by the Florida Building Commission for the type of inspections being conducted is the responsibility of an approved validation entity (or the code official, when the report holder does not possess an approval by the Commission).

This supplement expires concurrently with the master report, reissued July 2018.