

Bi-directional (BiDi) 10G SFP+ transceivers are high performance, cost effective modules supporting 20 km transmission distance with single-mode fiber.

These modules each accept 1 LC connector.

In order to function correctly, these SFPs must be used as a pair: SSF-SFP-SM10GBDA matched with SSF-SFP-SM10GBDB.

These single-mode transceivers are small form factor pluggable modules for duplex optical data communications such as 10GBASE-LR/LW defined by IEEE 802.3ae. The SFP+ 20-pin connector allows hot plug capability.

Modules are designed for single-mode fiber and operate at a nominal wavelength of 1270nm or 1330nm. The transmitter section uses a multiple quantum well DFB, which is class 1 laser compliant according to International Safety Standard IEC-60825. The receiver section uses an integrated InGaAs detector preamplifier (IDP) mounted in an optical header and a limiting post-amplifier IC.

Transceivers are compatible with SFP Multi-Source Agreement (MSA) and SFF-8472.



Features

- Supports 9.95Gb/s to 10.3Gb/s data rates
- Simplex LC Connector Bi-Directional SFP+ Optical Transceiver
- Single 3.3V Supply
- Up to 20km on 9/125um SMF
- A:1270nm DFB Laser transmitter,1330nm receiver
- B:1330nm DFB Laser transmitter,1270nm receiver
- Compliant with IEEE 802.3ae 10GBASE-LR and 10GBASE-LW
- SFP+ MSA SFF-8431 Compliant
- Digital Diagnostic SFF-8472 Compliant
- RoHS compliant and Lead Free
- Operating case temperature:
• Standard: 0 ~ 70 °C

Applications

- 10GBASE-LR at 10.3125Gbps
- 10GBASE-LW at 9.953Gbps
- Other Optical Links

PART NUMBER	DESCRIPTION
SSF-SFP-SM10GBDA	10G SFP+ transceiver BiDi T:1270/R:1330nm, 20Km max reach
SSF-SFP-SM10GBDB	10G SFP+ transceiver BiDi T:1330/R:1270nm, 20Km max reach

General Specifications

	SSF-SFP-SM10GBDA	SSF-SFP-SM10GBDB
Form factor	SFP	SFP
Speed	9.95 to 10.3Gb/s	9.95 to 10.3Gb/s
Optical connector	Single LC	Single LC
Operating distance	20Km	20Km
Power	Single 3.3V	Single 3.3V
Compliance	MSA SFF-8431, RoHS	MSA SFF-8431, RoHS
Operating mode	Bi-Directional	Bi-Directional
Fiber type	Single-mode 9/125um, single strand	Single-mode 9/125um, single strand
Wavelength	Tx:1270nm/Rx:1330nm	Tx:1330nm/Rx:1270nm
Digital Diagnostic	Yes (SFF-8472 compliant)	Yes (SFF-8472 compliant)

Absolute Maximum Ratings

These values represent the damage threshold of the module. Stress in excess of any of the individual Absolute Maximum Ratings can cause immediate catastrophic damage to the module even if all other parameters are within Recommended Operating Conditions.

PARAMETER	SYMBOL	MIN	MAX	UNIT
Supply Voltage	V _{CC}	-0.5	+3.6	V
Storage Temperature	T _c	-40	+85	°C
Operating Case Temperature	T _c	0	+70	°C
Relative Humidity	RH	0	85	%

Recommended Operating Conditions

PARAMETER	SYMBOL	MIN	TYPICAL	MAX	UNIT
Supply Voltage	V _{CC}	3.0	3.3	3.6	V
Supply Current	I _{CC}		200	300	mA
Operating Case Temperature	TC	0	25	70	°C
Module Power Dissipation	P _m	-	0.7	1.1	W

Notes:

[1] Supply current is shared between VCCTX and VCCR_X.

[2] In-rush is defined as current level above steady state current requirements.

Electrical Characteristics

($T_{op} = 0$ to $70C^{\circ}$ $V_{cc} = 3.0$ to 3.60 Volts)

PARAMETER	SYMBOL	MIN	TYPICAL	MAX	UNIT	NOTES
Supply Voltage	V_{cc}	3.00		3.60	V	1
Supply Current	I_{cc}		200	300	mA	1
TRANSMITTER						
Input differential impedance	R_{in}		100		Ω	2
Single ended data input swing	$V_{in,pp}$	150		1200	mVpp	
Transmit Disable Voltage	VD	2		VCC	V	
Transmit Enable Voltage	VEN	Vee		Vee+0.8	V	3
RECEIVER						
Output differential impedance	R_{out}		100		Ω	2
Single ended data output swing	$V_{out,pp}$	300		700	mV	4
LOS Fault	VLOS fault	2		VCCHOST	V	5
LOS Normal	VLOS norm	Vee		Vee+0.8	V	5

Notes:

1. Module power consumption never exceeds 1W.
2. AC coupled.
3. Or open circuit.
4. Into 100 ohm differential termination.
5. LOS is LVTTTL. Logic 0 indicates normal operation; logic 1 indicates no signal detected.

Optical and Electrical Characteristics

($T_{op} = 0$ to $70C^{\circ}$ $V_{cc} = 3.0$ to 3.60 Volts)
 SSF-SFP-SM10GBDA: (1270 DFB & PIN/TIA)

PARAMETER	SYMBOL	MIN	TYPICAL	MAX	UNIT	NOTES
TRANSMITTER						
Optical Wavelength	λ_c	1260	1270	1280	nm	
Side Mode Suppress Ratio	SMSR	30			dB	
Spectral Width(-20dB)	$\Delta\lambda$		1	nm		
Average Output Power	P_{op}	-2		2	dBm	1
Extinction Ratio	ER	3.5			dB	
Eye Mask	Compliant with IEEE 802.3					
Transmitter and Dispersion Penalty	TDP		3.2	dB		
Average Power of OFF Transmitter			-30	dBm		
Relative Intensity Noise	RIN			-128	dB/Hz	
RECEIVER						
Receiver	λ_c	1260		1360	nm	
Average Receiver Power	RSENS			-14.1	dBm	1,2
Receiver Overload	PMAX			+0.5	dBm	
Centre Wavelength	λ_c	1320		1340	nm	
LOS De-Assert	$LOSD$			-15	dBm	
LOS Assert	LOSA	-30			dBm	
LOS Hysteresis	0.5			dB		4

- Notes:**
1. Average Receiver Power (Min) is informative and not the principal indicator of signal strength. A received power below this value cannot be compliant.
 2. Measured with a PRBS2³¹-1 test pattern @10.3125Gbps, BER≤10⁻¹²

Optical and Electrical Characteristics

SSF-SFP-SM10GBDB: (1330 DFB & PIN/TIA)

PARAMETER	SYMBOL	MIN	TYPICAL	MAX	UNIT	NOTES
TRANSMITTER						
Optical Wavelength	λ_C	1320	1330	1340	nm	
Side Mode Suppress Ratio	SMSR	30			dB	
Spectral Width(-20dB)	$\Delta\lambda$			1	nm	
Average Output Power	P_{Pop}	-2		2	dBm	1,2
Extinction Ratio	ER	3.5			dB	
Eye Mask	Compliant with IEEE 802.3					
Transmitter and Dispersion Penalty	TDP			3.2	dB	
Average Power of OFF Transmitter			-30	dBm		
Relative Intensity Noise	RIN			-128	dB/Hz	
RECEIVER						
Average Receiver Power	RSENS			-14.1	dBm	2,3
Receiver Overload	PMAX			+0.5	dBm	
Centre Wavelength	λ_C	1260		1270	nm	
LOS De-Assert	$LOSD$			-15	dBm	
LOS Assert	$LOSA$	-30			dBm	
LOS Hysteresis	0.5			dB		
LOS Hysteresis	0.5			dB		4

Notes:

1. Output is coupled into a 9/125um SMF.
2. Average Receiver Power (Min) is informative and not the principal indicator of signal strength. A received power below this value cannot be compliant.
3. Measured with a PRBS231-1 test pattern @10.3125Gbps, BER \leq 10⁻¹²

Pin Descriptions

Pin Diagram

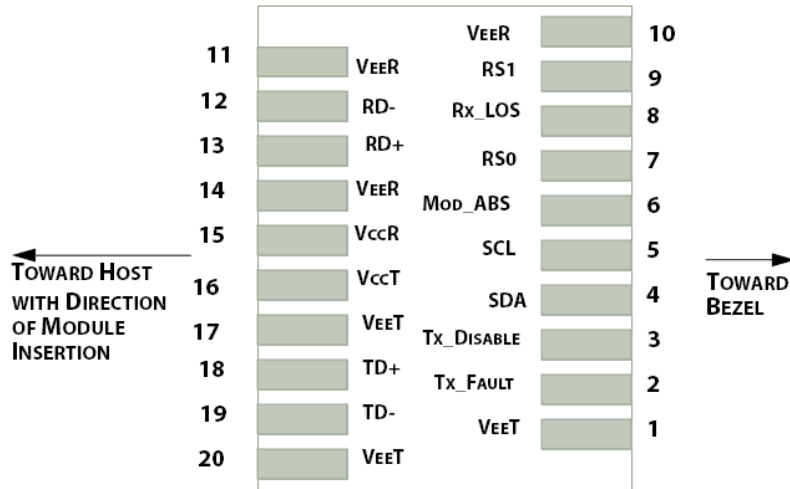

Pin Descriptions

PIN	SYMBOL	DESCRIPTION
1	VEET [1]	Transmitter Ground
2	Tx_FAULT [2]	Transmitter Fault
3	Tx_DIS [3]	Transmitter Disable. Laser output disabled on high or open
4	SDA [2]	2-wire Serial Interface Data Line
5	SCL [2]	2-wire Serial Interface Clock Line
6	MOD_ABS [4]	Module Absent. Grounded within the module
7	RS0 [5]	RS0 for Rate Select: Open or Low = Module supports ≤4.25Gbps High = Module supports 9.95 Gb/s to 10.3125 Gb/s
8	RX_LOS [2]	Loss of Signal indication. Logic 0 indicates normal operation
9	RS1 [5]	No connection required
10	VEER [1]	Receiver Ground
11	VEER [1]	Receiver Ground
12	RD-	Receiver Inverted DATA out. AC Coupled
13	RD+	Receiver DATA out. AC Coupled
14	VEER [1]	Receiver Ground
15	VCCR	Receiver Power Supply
16	VCCT	Transmitter Power Supply
17	VEET [1]	Transmitter Ground
18	TD+	Transmitter DATA in. AC Coupled
19	TD-	Transmitter Inverted DATA in. AC Coupled
20	VEET [1]	Transmitter Ground

Notes:

- [1] Module circuit ground is isolated from module chassis ground within the module.
- [2].should be pulled up with 4.7k – 10k ohms on host board to a voltage between 3.15V and 3.6V.
- [3]Tx_Disable is an input contact with a 4.7 kΩ to 10 kΩ pullup to VccT inside the module.
- [4]Mod_ABS is connected to VeeT or VeeR in the SFP+ module. The host may pull this contact up to Vcc_Host with a resistor in the range 4.7 kΩ to 10 kΩ. Mod_ABS is asserted “High” when the SFP+ module is physically absent from a host slot.
- [5] RS0 and RS1 are module inputs and are pulled low to VeeT with > 30 kΩ resistors in the module.

Host Board Power Supply Filters Circuit

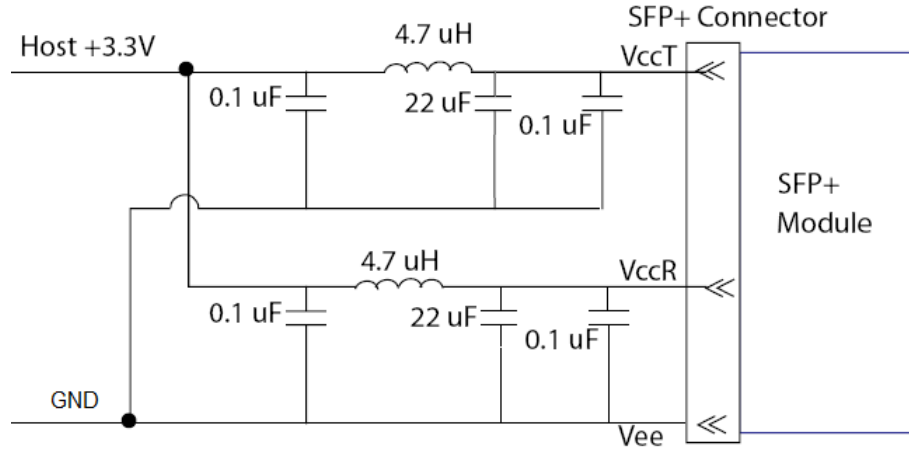

Host-Module Interface

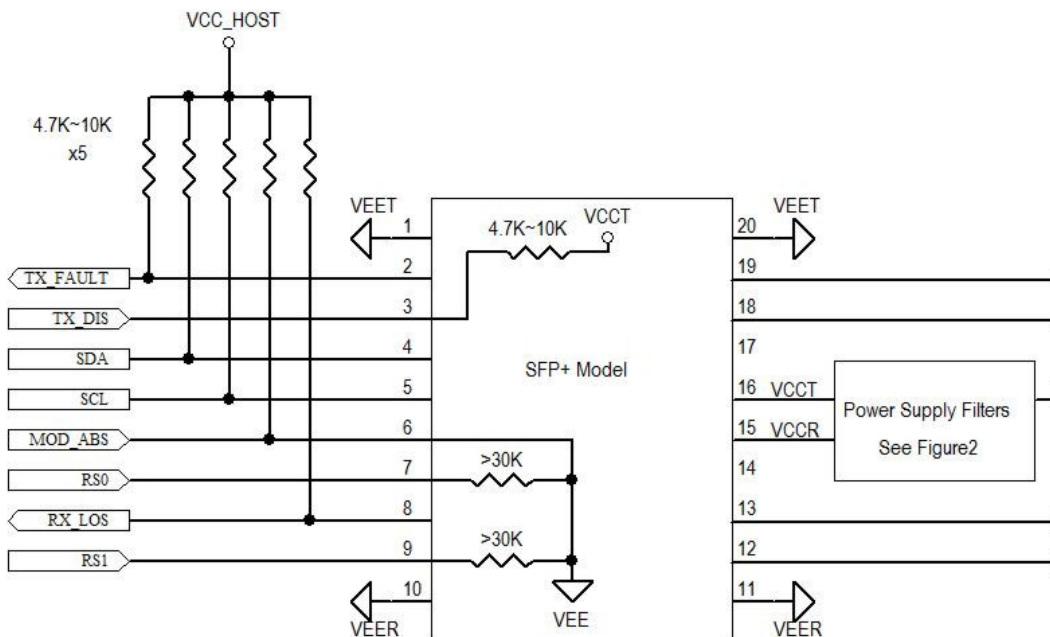

Mechanical Dimensions

