

This 1310 nm DFB 25Gb/s SFP28 LR transceiver is designed to transmit and receive optical data over single-mode optical fiber for link length up to 10km.

The module optical connection is duplex LC and shall be compatible with SFP+ 28Gbps and backward compatible with legacy 10G SFP+ pluggable. The SFP28 LR module is a dual directional device with a transmitter and receiver plus a control management interface (2-wire interface) in the same physical package. 2-wire interface is used for serial ID, digital diagnostics and module control function.

The module operates by a single +3.3V power supply. LVCMOS/ LVTTTL global control signals, such as Module Present, Reset, Interrupt and Low Power Mode, are available with the modules. The SFP28 LR module electrical interface is compliant to OFI CEI VSR-28G-VSR. It has been designed to meet the harshest external operating conditions including temperature, humidity and EMI interference. The module offers very high functionality and feature integration, accessible via a two-wire serial interface.



GENERAL SPECIFICATIONS

ITEM	DETAIL
Speed	Multirate 25G/28G
Optical connector	Dual LC
Operating distance	max. 10km over OS2
Power Supply	Single 3.3V
Fiber type	Multimode 50/125um OM4 or OM3, dual strand
Wavelength	1310nm
Compliance	MSA SFF-8431, RoHS
Digital Diagnostic	Yes (SFF-8472 compliant)

FEATURES AND BENEFITS

- Compliant to IEEE802.3by 25GBASE-LR
- Up to 25.78Gb/s data links
- 25G 1310nm DFB transmitter
- 25G PIN photo-detector
- Operating case temperature: 0 to 70°C
- 2-wire interface for management specifications compliant with SFF-8472 digital diagnostic monitoring interface for optical transceivers
- All-metal housing for superior EMI performance
- 25G electrical interface (OIF CEI-28G-VSR)
- Accepts LC duplex connectors
- Maximum power consumption 1.5W
- Advanced firmware allows customer system encryption information to be stored in transceiver
- RoHS compliant

APPLICATIONS

- High-speed storage area networks
- Computer cluster cross-connect
- Custom high-speed data pipes
- Inter Rack Connection

PART NUMBER	DESCRIPTION
SSF-SFP28-25GLR	25G SFP28 LR transceiver SM 1310nm, 10Km reach, Dual LC

FUNCTIONAL DESCRIPTION

The transmitter converts 25Gbit/s serial PECL or CML electrical data into serial optical data compliant with the 25GBASE-LR standard. An open collector compatible Transmit Disable (Tx_Dis) is provided. Logic “1” or no connection on this pin will disable the laser from transmitting. Logic “0” on this pin provides normal operation. The transmitter has an internal automatic power control loop (APC) to ensure constant optical power output across supply voltage and temperature variations. An open collector compatible Transmit Fault (Tx_Fault) is provided. TX_Fault is module output contact that when high, indicates that the module transmitter has detected a fault condition related to laser operation or safety. The TX_Fault output contact is an open drain/collector and shall be pulled up to the Vcc_Host in the host with a resistor in the range 4.7-10 kΩ. TX_Disable is a module input contact. When TX_Disable is asserted high or left open, the SFP28 module transmitter output shall be turned off. This contact shall be pulled up to VccT with a 4.7 kΩ to 10 kΩ resistor.

The receiver converts 25Gbit/s serial optical data into serial PECL/CML electrical data. An open collector compatible Loss of Signal is provided. Rx_LOS when high indicates an optical signal level below that specified in the relevant standard. The Rx_LOS contact is an open drain/collector output and shall be pulled up to Vcc_Host in the host with a resistor in the range 4.7-10 kΩ, or with an active termination. Power ROBOfiber, Inc., 3000F Danville Blvd., Ste 300, Alamo, CA 94507 US www.robofiber.com, toll-free/fax: 888-27-FIBER Page 2 of 11 Rev.1.1 Mar 2016 supply filtering is recommended for both the transmitter and receiver. The Rx_LOS signal is intended as a preliminary indication to the system in which the SFP28 is installed that the received signal strength is below the specified range. Such an indication typically points to non-installed cables, broken cables, or a disabled, failing or a powered off transmitter at the far end of the cable.

TRANSCEIVER BLOCK DIAGRAM

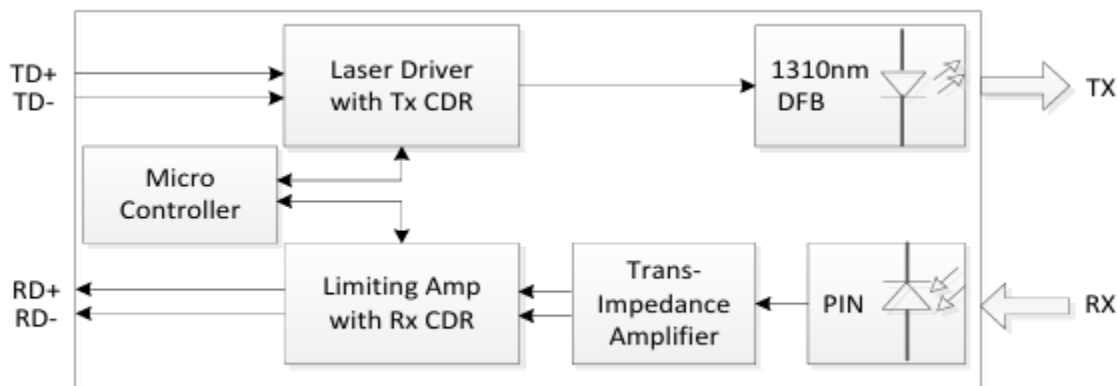

Figure 1. Transceiver Block Diagram

PIN DEFINITION

The SFP28 modules are hot-pluggable. Hot pluggable refers to plugging in or unplugging a module while the host board is powered. Its connector and cage shall be compatible with SFP+ 28Gb/s (SFP28, SFF-8402) and backward compatible with legacy 10G SFP+ 10Gb/s (SFF-8083) pluggable, or stacked connector with equivalent with equivalent electrical performance. Host PCB contact assignment is shown in Figure 2 and contact definitions are given in the PIN description table. SFP28 module contacts mates with the host in the order of ground, power, followed by signal as illustrated by Figure 3 and the contact sequence order listed in the PIN description table.

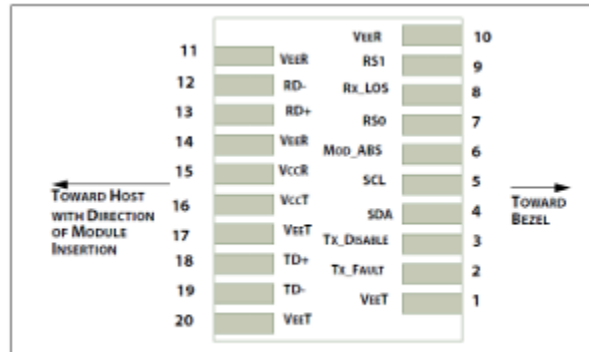
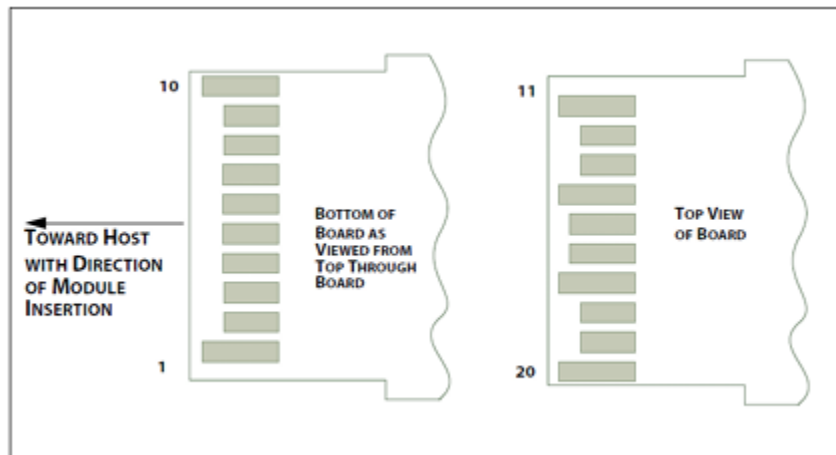

Figure 2. Module Interface to Host



PIN DESCRIPTION

CONTACTS	LOGIC	SYMBOL	NAME/DESCRIPTION	NOTES
1		VeeT	Module Transmitter Ground	1
2	LVTTL-O	TX_Fault	Module Transmitter Fault	
3	LVTTL-I	TX_Dis	Transmitter Disable; Turns off transmitter laser output	
4	LVTTL-I/O	SDA	2-Wire Serial Interface Data Line	2
5	LVTTL-I	SCL	2-Wire Serial Interface Clock	2
6		MOD_DEF0	Module Definition, Grounded in the module	
7	LVTTL-I	RS0	Receiver Rate Select	
8	LVTTL-O	RX_LOS	Receiver Loss of Signal Indication Active LOW	
9	LVTTL-I	RS1	Transmitter Rate Select (not used)	
10		VeeR	Module Receiver Ground	1
11		VeeR	Module Receiver Ground	1
12	CML-O	RD-	Receiver Inverted Data Output	
13	CML-O	RD+	Receiver Data Output	
14		VeeR	Module Receiver Ground	1
15		VccR	Module Receiver 3.3 V Supply	
16		VccT	Module Receiver 3.3 V Supply	
17		VeeT	Module Transmitter Ground	1
18	CML-I	TD+	Transmitter Non-Inverted Data Input	
19	CML-I	TD-	Transmitter Inverted Data Input	
20		VeeT	Module Transmitter Ground	1

Notes

1. Module ground pins GND are isolated from the module case.2. Shall be pulled up with 4.7K-10Kohms to a voltage between 3.15V and 3.45V on the host board.
2. Shall be pulled up the voltage between 3.15V and 3.47V with 4.7K – 10Kohms on the host board.

ABSOLUTE MAXIMUM RATINGS

These values represent the damage threshold of the module. Stress in excess of any of the individual Absolute Maximum Ratings can cause immediate catastrophic damage to the module even if all other parameters are within Recommended Operating Conditions.

PARAMETERS	SYMBOL	MIN.	MAX.	UNIT
Storage Temperature	T _s	-40	85	degC
Operating Case Temperature	T _{OP}	0	70	degC
Power Supply Voltage	V _{CC}	0	3.6	V
Relative Humidity	RH	5	85	%
Damage Threshold	TH _d	3.4		dBm

RECOMMENDED OPERATING CONDITIONS AND POWER SUPPLY REQUIREMENTS

Recommended Operating Environment specifies parameters for which the electrical and optical characteristics hold unless otherwise noted.

PARAMETER	SYMBOL	MIN	TYPICAL	MAX	UNIT	NOTES
Operating Case Temperature	T _c	0		70	°C	
Power Supply Voltage	V _{cc}	3.135	3.3	3.465	V	
Data Rate, each Lane			25.78125		Gb/s	
Data Rate Accuracy		-100		100	ppm	
Control Input Voltage High		2		V _{cc}	V	
Control Input Voltage Low		0		0.8	V	

ELECTRICAL CHARACTERISTICS

The following electrical characteristics are defined over the Recommended Operating Environment unless otherwise specified.

PARAMETER	TEST POINT	MIN	TYPICAL	MAX	UNITS	NOTES
Power Consumption				1.5	W	
Supply Current	I _{cc}			450	mA	
TRANSMITTER (EACH LANE)						
Overload Differential Voltage pk-pk	TP1a	900			mV	
Common Mode Voltage (V _{cm})	TP1	-350		2850	mV	1
Differential Termination Resistance Mismatch	TP1			10	%	At 1MHz
Differential Return Loss (SDD11)	TP1			See CEI-28G VSR Equation 13-19	dB	
Common Mode to Differential conversion and Differential to Common Mode conversion (SDC11, SCD11)	TP1			See CEI-28G VSR Equation 13-20	dB	
Stressed Input Test	TP1a	See CEI- 28G-VSR Section 13.3.11.2.1				
RECEIVER (EACH LANE)						
Differential Voltage, pk-pk	TP4			900	mV	
Common Mode Voltage (V _{cm})	TP4	-350		2850	mV	1
Common Mode Noise, RMS	TP4			17.5	mV	
"Differential Termination Resistance Mismatch"	TP4			10	%	At 1MHz
Common Mode to Differential conversion and Differential to Common Mode conversion (SDC22, SCD22)	TP4	See CEI- 28G-VSR Equation 13-21				

Common Mode Return Loss (SCC22)	TP4			-2	dB	2
Transition Time, 20 to 80%	TP4	9.5			ps	
Vertical Eye Closure (VEC)	TP4			5.5	dB	
Eye Width at 10-15 probability (EW15)	TP4	0.57			UI	
Eye Height at 10-15 probability (EH15)	TP4	228			mV	

Notes:

1. Vcm is generated by the host. Specification includes effects of ground offset voltage.
2. From 250MHz to 30GHz.

OPTICAL CHARACTERISTICS

PARAMETER	SYMBOL	MIN	TYPICAL	MAX	UNIT	NOTES
TRANSMITTER						
Center Wavelength	λ_t	1295		1325	nm	
Side Mode Suppression Ratio	SMSR	30			dB	
Average Optical Power	Pavg	-7		2	dBm	
Optical Power OMA	P _{OMA}	-4		2.2	dBm	1
Launch power in OMA minus TDEC		-5			dBm	
Transmitter Dispersion Penalty	TDP			2.7	dB	
Extinction Ratio	ER	3.5			dB	
Optical Return Loss Tolerance				20	dB	
Average Launch Power OFF Transmitter	Poff			-30	dBm	
Transmitter Eye Mask Definition {X1, X2, X3, Y1, Y2, Y3} - Hit ratio 1.5x10 ⁻³ hits per sample			{0.3, 0.38, 0.45, 0.35, 0.41, 0.5}			2
RECEIVER						
Center Wavelength	λ_r	1260		1350	nm	
Damage Threshold	TH _d	3.5			dBm	3
Average Receiver Power		-13.3		2	dBm	
Receiver Power (OMA) (Overload)				2.2	dBm	
Stressed Receiver Sensitivity (OMA)	SEN			-11.3	dBm	for BER = 5x10 ⁻⁵
Receiver Reflectance				-26	dB	
LOS Assert	LOSA	-30			dBm	
LOS Deassert	LOSD			-14	dBm	
LOS Hysteresis	LOSH	0.5			dB	
Conditions of Stress Receiver Sensitivity Test (Note 9)						
Vertical Eye closure Penalty, each lane			1.9		dB	

Stressed Eye J2 Jitter	J2	0.27	UI
Stressed Eye J4 Jitter	J4	0.39	UI
"Stressed Receiver Eye Mask Definition {X1, X2, X3, Y1, Y2, Y3} - Hit ratio 1.5x10 ⁻⁵ hits per sample"		{0.24, 0.5, 0.5, 0.24, 0.24, 0.4}	

Notes:

1. Even if the TDP < 1 dB, the OMA min must exceed the minimum value specified here.
2. Hit ratio 5x10⁻⁵ per sample
3. The receiver shall be able to tolerate, without damage, continuous exposure to a modulated optical input signal having this power level on one lane. The receiver does not have to operate correctly at this input power
4. Measured with conformance test signal receiver input for BER = 5x10⁻⁵
5. Vertical eye closure penalty, stressed eye J2 jitter, stressed eye J4 jitter, and SRS eye mask definition are test conditions for measuring stressed receiver sensitivity.
6. They are not required characteristics of the receiver.

DIGITAL DIAGNOSTIC FUNCTIONS

The following digital diagnostic characteristics are defined over the normal operating conditions unless otherwise specified.

PARAMETER	SYMBOL	MIN	MAX	UNIT	CONDITIONS
Temperature Monitor Absolute Error	DMI_Temp	-3	3	degC	Over operating temperature
Supply Voltage Monitor Absolute Error	DMI_VCC	-0.1	0.1	V	Full operating range
RX Power Monitor Absolute Error	DMI_RX	-2	2	dB	1
Bias Current Monitor	DMI_Ibias	-10%	10%	mA	
TX Power Monitor Absolute Error	DMI_TX	-2	2	dBm	1

Notes:

1. Due to measurement accuracy of different single-mode fibers, there could be an additional +/- 1 dB fluctuation, or a +/- 3 dB total accuracy.

MECHANICAL DIMENSIONS

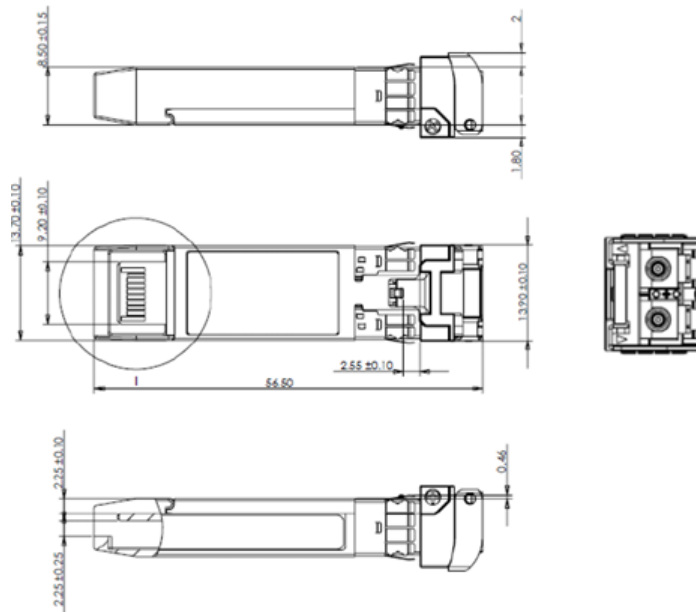

ESD

This transceiver is specified as ESD threshold 1kV for high speed data pins and 2kV for all other electrical input pins, tested per MIL-STD-883, Method 3015.4 / JESD22-A114-A (HBM). However, normal ESD precautions are still required during the handling of this module. This transceiver is shipped in ESD protective packaging. It should be removed from the packaging and handled only in an ESD protected environment.

Laser Safety

This is a Class 1 Laser Product according to EN 60825-1:2014. This product complies with 21 CFR 1040.10 and 1040.11 except for deviations pursuant to Laser Notice No. 50, dated (June 24, 2007).

Caution: Use of controls or adjustments or performance of procedures those specified herein may result in hazardous radiation exposure.