



by POTTER

EVAX-150/200

Voice Evacuation System

Features

- Clean Dead-front Construction
- 8 Megabyte MP3 driver
- 25 or 70 VRMS Field Selectable Class A / B Speaker Circuit
- 120 VAC Power Supply and Battery Charger
- Live Microphone Override of Message and Tone
- Analog Addressable Compatible
- High Reliability, No Maintenance, Fully Supervised
- Easy Installation and Operation
- Studio Quality Voice Recordings Built in Alarm and Alert Signals
- Works with 12 or 24VDC Fire Alarm Panels Works with Microprocessor based and Networked Fire Alarm Systems
- 3 Minute Message Restart on Microphone Key
- 24 Hour Backup with two 12V 7Ahr Batteries



6911-1446:100

Description

The EVAX-200 / EVAX-150 panels provide 200W and 150W of speaker power respectively. Speaker zones can be configured for general alarm or alarm by zone operation as required. Digital message repeater, microphone, 120 VAC power supply and battery charger are all built in. The EVAX Series voice evacuation can be configured for Churches, Restaurants, Movie Theaters, Auditoriums, and High Rise buildings.

The paging microphone is an integral component removal of the microphone will cause a "Trouble" condition which will be reporting locally, as well as through the FACP. The EVAX-150 / EVAX-200 is housed in a surface or semi-flush mounted back box with a hinged and key locked door.

Technical Specifications

Back Box Dimensions (WxHxD)	14.5 x 27 x 4"
Color	Charcoal Grey (Standard) Red (Optional)
EVX-50-50E Watt Module	
Primary Power	0.8 A @ 120VAC
24VDC Battery Power	0.15 Standby 0.8 Alarm
Output	50 Watts @ 25/70 VRMS
EVX-100-100E Watt Module	
Primary Power	1A @ 120VAC
24VDC Battery Power	0.16 Standby 0.6 Alarm
Output	100 Watts @ 25/70 VRMS

Typical Wiring EVAX-150/200

Fig 1

Typical Installation

Typical Installation:

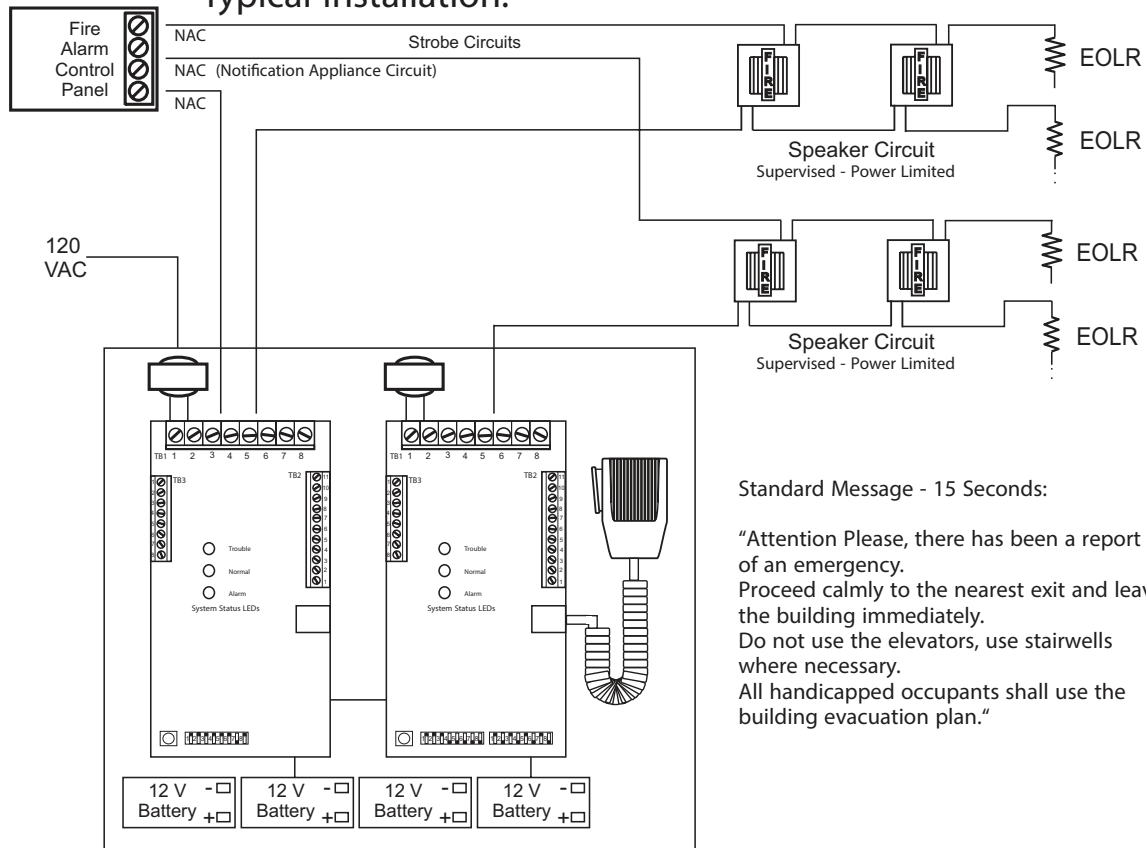

Standard Message - 15 Seconds:

“Attention Please, there has been a report of an emergency. Proceed calmly to the nearest exit and leave the building immediately. Do not use the elevators, use stairwells where necessary. All handicapped occupants shall use the building evacuation plan.”

Engineering Specifications

The voice evacuation system shall be Evax Systems Series EVAX 150/200 or approved equal. The voice evacuation system shall provide 25/50/100 watts signal power and 25/50/100 watts voice power, and shall be UL Listed. The voice evacuation system shall be micro-processor based, and shall contain an integral microphone, 150/200W audio amplifier, tone generator, digital message repeater, 120VAC power supply and battery charger.

The voice evacuation message/signal shall be broadcast until the Fire Alarm Control Panel (FACP) is reset, or until fire emergency personnel interrupt the broadcast with a manual page. On reset system shall automatically return to standby (normal operating) condition. A secondary message shall be provided which can be triggered by the closure of a contact from either the FACP or from any normally open contact device. Remote paging microphone(s) will be supported by the system through a supervised circuit. Remote microphone(s) may be mounted up to 5000 feet away from the voice evacuation panel.



by POTTER

EVAX-150/200

Voice Evacuation System

EVAX Ordering Information

Model Number	Description	LB (KG)
<i>Panels include DMR, temporal pattern tone, standard message, microphone, power supply and battery charger.</i>		
EVAX-150	150 W Voice Evacuation System with: • Power Supply/ Battery Charger	32 (14.5)
EVAX-150/8Z	• Paging Microphone • Digital Message Repeater	32 (14.5)
EVAX-150/12Z	Available with : • 8 Speaker Zones (8Z) • 12 Speaker Zones (12Z)*	32 (14.5)
EVAX-150/16Z	• 16 Speaker Zones (16Z)*	32 (14.5)
EVAX-200	200 W Voice Evacuation System with: • Power Supply / Battery Charger	32 (14.5)
EVAX-200/8Z	• Paging Microphone • Digital Message Repeater	32 (14.5)
EVAX-200/12Z	Available with: • 8 Speaker Zones (8Z) • 12 Speaker Zones (12Z)*	32 (14.5)
EVAX-200/16Z	• 16 Speaker Zones (16Z)*	32 (14.5)

Note: The 4Z/8Z/12Z/16Z models include the required EVX-ZM-ASSM card(s).