



The Pro's Connectivity Since 1974

USB5GX-520K

Pro AV/IT Integrator Series™ Seven (7) Port SuperSpeed USB 5Gbps Extender Kit up to 330ft Over Cat6A with USB-C & USB-A Data Ports, USB Host Switching, RS232, FSYNC GPIO



User Manual

VER 1.0

Thank you for purchasing this product

For optimum performance and safety, please read these instructions carefully before connecting, operating or adjusting this product. Please keep this manual for future reference.

Surge protection device recommended

This product contains sensitive electrical components that may be damaged by electrical spikes, surges, electric shock, lighting strikes, etc. Use of surge protection systems is highly recommended in order to protect and extend the life of your equipment.

Caution

This product requires the use of UTP connectors. Please connect in direct interconnection method and do not cross connect.

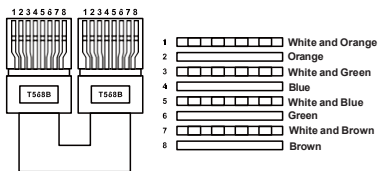

Direct Interconnection Method

Table of Contents

1. Introduction.....	1
2. Features.....	1
3. Package Contents.....	1
4. Specifications.....	2
5. Operation Controls and Functions.....	3
5.1 Transmitter Panel.....	3
5.2 Receiver Panel.....	4
6. API Commands.....	6
7. Application Example.....	9

1. Introduction

The Comprehensive USB5GX-520K is a seven (7) port USB 3.2 super speed 5Gbps extension solution. The USB5GX-520K USB Extender allows you to extend a USB 3.2 (5Gbps) signal up to 100 meters (328 feet) using a single CAT6A cable. The transmitter has two input options: one USB-C port and one USB-B port, which you can switch between. The receiver provides one USB-C port and three USB-A ports for connecting devices. With its bi-directional 24V PoC (Power over Cable) feature, you only need to power either the transmitter or the receiver.

The USB5GX-520K is ideal for transmitting USB signals over long distances, making it useful for devices such as webcams, PTZ cameras, video bars, keyboards, mice, USB microphones, flash drives, printers, scanners, touch screens, VR headsets, USB capture cards and more.

2. Features

- Extension of USB 3.2 5Gbps up to 100m/328ft via CAT6a cable.
- USB 3.2 Gen 1 connectivity with data transfer rate up to 5Gbps.
- Backwards compatible with USB 2.0 and 1.1.
- Hardware acceleration for isochronous and bulk transfer.
- TX features 1x USB-B and 1x USB-C selectable input ports.
- Supports auto switching and manual switching modes.
- RX features 1x USB-C and 3x USB-A output ports (2x 5V@1A and 2x 5V@1.5A).
- Supports RS-232 pass-through and API control.
- Supports firmware upgrade via USB-C service port.
- Supports FSYNC GPIO pass-through for industry camera use.
- Supports bi-directional 24V PoC (Power over Cable), when TX or RX gets power, the other end does not need an external power supply.
- Plug-and-play with no drivers, downloads, or software required.
- Supports all USB transfer types (Control, Interrupt, Isochronous and Bulk)
- Optimized for cameras and video capture devices & touch screens.
- Works with all major operating systems: Windows®, macOS™, Linux® and Chrome OS™.
- 3 Year Worry-Free Warranty.

3. Package Contents

- 1x USB5GX-520K (Tx & Rx Kit)
- 1x 24V/3.75A DC Power Adapter with locking connector
- 4 x Mounting Ear
- 8x Machine Screw (KM3*4)
- 2x 4pin-3.5mm Phoenix Connector (Male)
- 1x Operation Manual

4. Specifications

Technical	
USB Protocol	SuperSpeed USB 3.2 Gen 1
Transmission Rate	Up to 5Gbps
Transmission Distance	5Gbps = Cat 5e/6 70m (230ft) 5Gbps = Cat 6A/7 100m (330ft) 5Gbps = USB cable 1.5m (4.9ft) Also supports active USB cables
Cat Cable Requirements	Cat6A cable is recommended for optimal performance.
ESD Protection	IEC 61000-4-2: ±8kV (Air-gap discharge), ±4kV (Contact discharge)
Connections	
Transmitter	Input: 1× HOST 1 [USB Type C, 24-pin female] 1× HOST 2 [USB Type B, 9-pin female] Output: 1× USB-C DEVICE [USB Type C, 24-pin female] 2× USB-A DEVICE [USB Type A, 9-pin female] 1× HDBT-USB3 [RJ45 connector, 24V PoC] Control: 1× RS-232 [3pin-3.5mm phoenix connector] 1× FSYNC [1pin-3.5mm phoenix connector] 1× SERVICE [USB Type C, firmware update port]
Receiver	Input: 1× HDBT-USB3 [RJ45 connector, 24V PoC] Output: 3× USB-A DEVICE [USB Type A, 9-pin female] 1× USB-C DEVICE [USB Type C, 24-pin female] Control: 1× RS-232 [3pin-3.5mm phoenix connector] 1× FSYNC [1pin-3.5mm phoenix connector] 1× SERVICE [USB Type C, firmware update port]
Mechanical	
Housing	Metal Enclosure
Color	Black
Dimensions	Transmitter / Receiver: 140mm [W] × 75mm [D] × 23mm [H]
Weight	Transmitter: 313g; Receiver: 318g
Power Supply	Input: AC 100~240V 50/60Hz Output: DC 24V/3.75A
Power Consumption	Transmitter: 23W (Max); Receiver: 35W (Max)
Operating Temperature	0°C ~ 40°C / 32°F ~ 104°F
Storage Temperature	-20°C ~ 60°C / -4°F ~ 140°F
Operating Humidity	20%~80% relative humidity, non-condensing
Storage Humidity	10%~90% relative humidity, non-condensing

5. Operation Controls and Functions

5.1 Transmitter Panel

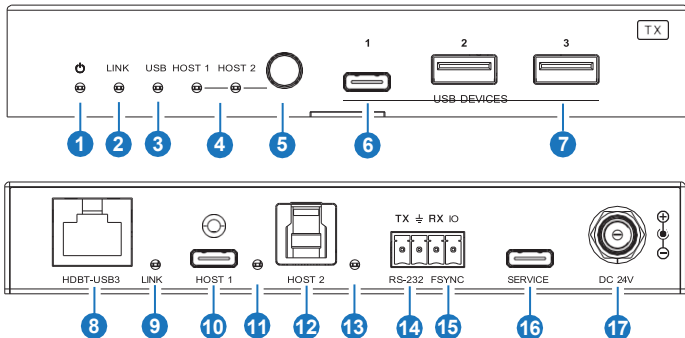

No.	Name	Function Description
1	Power LED	The LED will be on when the transmitter is powered on.
2	LINK LED	Connection signal indicator. • On: Transmitter and Receiver are connected and linked. • Off: Transmitter and Receiver are not connected.
3	USB LED	USB signal indicator. • On: USB 3.0 signal is detected. • Blinking: USB 2.0 signal is detected. • Off: USB signal is not detected.
4	HOST (1~2) LED	When HOST 1/2 is selected, the corresponding LED will be on.
5	HOST switch button	Press this button to switch between HOST 1 and HOST 2.
6	USB DEVICES (1)	Downlink USB-C port, connected to USB devices such as U disk or hard disk. Its output power is up to 5V/1A.
7	USB DEVICES (2~3)	Downlink USB-A port, connected to USB devices such as U disk or hard disk. Its output power is up to 5V/1A.

No.	Name	Function Description
8	HDBT-USB3	Connects to the HDBT-USB3 port on Receiver with CAT6a cable.
9	LINK LED	Connection signal indicator. <ul style="list-style-type: none"> ▪ On: Transmitter and Receiver are connected and linked. ▪ Off: Transmitter and Receiver are not connected.
10	HOST 1	Uplink USB-C port, connected to a PC or host. It can be used to update HUB firmware.
11	HOST 1 LED	The LED will be on when USB signal is detected on HOST 1 port.
12	HOST 2	Uplink USB-B port, connected to a PC or host. It can be used to update HUB firmware.
13	HOST 2 LED	The LED will be on when USB signal is detected on HOST 2 port.
14	RS-232	3pin phoenix connector, connected to a PC or control system for RS-232 command pass-through.
15	FSYNC	FSYNC port, the level pass through from Transmitter to Receiver, to synchronize the external devices. Default level range is 0~5V.
16	SERVICE	Firmware update port, supporting USB 2.0.
17	DC 24V	DC 24V/3.75A power input port.

5.2 Receiver Panel

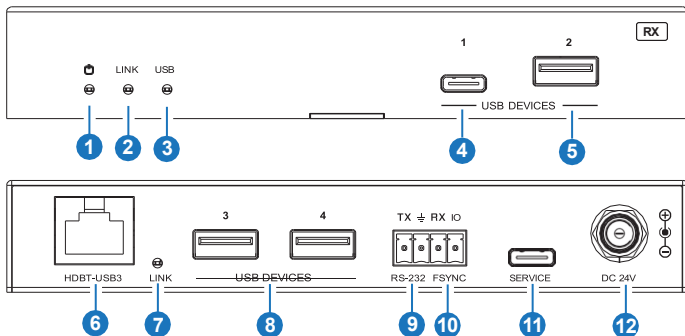

No.	Name	Function Description
1	Power LED	The LED will be on when the receiver is powered on.
2	LINK LED	Connection signal indicator. <ul style="list-style-type: none"> ▪ On: Transmitter and Receiver are connected and linked. ▪ Off: Transmitter and Receiver are not connected.
3	USB LED	USB signal indicator. <ul style="list-style-type: none"> ▪ On: USB 3.0 signal is detected. ▪ Blinking: USB 2.0 signal is detected. ▪ Off: USB signal is not detected.
4	USB DEVICES 1	Downlink USB-C port, connected to USB devices such as U disk or hard disk. Its output power is up to 5V/1A.
5	USB DEVICES 2	Downlink USB-A port, connected to USB devices such as U disk or hard disk. Its output power is up to 5V/1A.
6	HDBT-USB3	Connects to the HDBT-USB3 port on Transmitter with CAT6a cable.
7	LINK LED	Connection signal indicator. <ul style="list-style-type: none"> ▪ On: Transmitter and Receiver are connected and linked. ▪ Off: Transmitter and Receiver are not connected.
8	USB DEVICE (3~4)	Downlink USB-A port, connected to USB devices such as U disk or hard disk. Its output power is up to 5V/1.5A.
9	RS-232	3pin phoenix connector, connected to a PC or control system for RS-232 command pass-through.
10	FSYNC	FSYNC port, the level pass through from Transmitter to Receiver, to synchronize the external devices. Default level range is 0~5V.
11	SERVICE	Firmware update port, supporting USB 2.0.
12	DC 24V	DC 24V/3.75A power input port.

6. API Commands

This product supports API commands control. Connect the SERVICE or RS-232 port of the product to a PC, then open a Serial Command tool on PC to send ASCII commands to control the product. The API commands list is shown below.

ASCII Commands				
1. Service port (USB-C virtual RS-232) communication protocol (Internal debug) Baud rate: 115200(Fixed) Data bit: 8 Stop bit: 1 Parity bit: none The end mark of command is "<CR><LF>"				
2. Phoenix RS-232 port communication protocol (Connect to control system) Baud rate: 4800~115200(Configurable) Data bit: 8 Stop bit: 1 Parity bit: none The end mark of command is "<CR><LF>"				
Command	Function	Example	Feedback	Default
?	Get the list of all commands	?		
help	Get the list of all commands	help		
get fw version	Get firmware version	get fw version	1.0.0	
set reboot	Reboot the device	set reboot	Reboot... System Initializing... Initialization Finished! FW: 1.0.0	
set reset	Reset to factory defaults	set reset	Sure to RESET to default settings? Type "Yes" after next prompt to confirm...	
get status	Get system status	get status	Please refer to the note at the end of the list.	
set key on/off	Set front panel key on/off	set key on set key off	Set key on Set key off	on
get key	Get front panel key on/off status	get key	Key on	
set baud x	Set RS-232 baud rate to x bps x=1: 4800 x=2: 9600 x=3: 19200 x=4: 38400 x=5: 57600 x=6: 115200	set baud 6	Set baud rate 115200	115200
get baud	Get RS-232 baud rate	get baud	Baud rate 115200	

Command	Function	Example	Feedback	Default
set input x	Set USB host input port (x=1~2) x=1: USB host 1 (USBC) x=2: USB host 2 (USBB)	set input 1	Set input USB host 1	1
get input	Get USB host input port	get input	Input USB host 1	
get usb5v x	Get USB host input port 5V (x=0~2) x=0: all USB host inputs x=1: USB host 1 (USBC) x=2: USB host 2 (USBB)	get usb5v 0	USB host 1: 5V USB host 2: none	
set autoswitch x	Set auto-switching on/off (USB 5V detection) x=On, Off	set autoswitch on	Set autoswitch on	on
get autoswitch	Get auto-switching status	get autoswitch	Autoswitch on	
set tx usbd x power y	Set TX USB device ports (x=0~3) power to (y=0~2) x=0: TX all USB device ports x=1: TX USB device 1 (USBC) x=2: TX USB device 2 (USBA) x=3: TX USB device 3 (USBA) y=0: Force power off y=1: Follow USB host power y=2: Force power on	set tx usbd 0 power 1	Set TX all USB device ports power follow USB host power	1
get tx usbd x power	Get TX USB device ports (x=0~3) power status x=0: TX all USB device ports x=1: TX USB device 1 (USBC) x=2: TX USB device 2 (USBA) x=3: TX USB device 3 (USBA)	get tx usbd 0 power	TX all USB device ports power follow USB host power	
set rx usbd x power y	Set RX USB device ports (x=0~4) power to (y=0~2) x=0: RX all USB device ports x=1: RX USB device 1 (USBC) x=2: RX USB device 2 (USBA) x=3: RX USB device 3 (USBA) x=4: RX USB device 4 (USBA) y=0: Force power off y=1: Follow USB host power y=2: Force power on	set rx usbd 0 power 1	Set RX all USB device ports power follow USB host power	1

Command	Function	Example	Feedback	Default
get rx usbd x power	Get RX USB device ports (x=0~4) power status x=0: RX all USB device ports x=1: RX USB device 1 (USBC) x=2: RX USB device 2 (USBA) x=3: RX USB device 3 (USBA) x=4: RX USB device 4 (USBA)	get rx usbd 0 power	RX all USB device ports power follow USB host power	
set hdbt update	Set service port to HDBT UART for FW update	set hdbt update	Hdbt update	

Note: The feedback of the command of “get status” is as follow. (The middle line ends with <LF><CR> and the last line ends with <CR><LF>.)

=====
Status Info 2-Port USB 3.2 Gen 1 Extender

TX/RX FW 1.0.0

Source	Key	Baud	Autoswitch
01	On	115200	On

Input	USB_Power
01	5V
02	None

Output	USB_Power
TX_01	Follow_Input
TX_02	Follow_Input
TX_03	Follow_Input
RX_01	Follow_Input
RX_02	Follow_Input
RX_03	Force_Off
RX_04	Force_On

=====

7. Application Example

