

## SB-2000 Timed Electronic Shunt Series



**SB-2000**  
Timed Electronic  
Shunt Switch

- Adjustable Timed Shunt with Indicating LED
- Allows Exit Without Disarming System
- External Power
- Eliminates Need for Code
- Residential and Commercial Applications

The GRI SB-2000 is designed to electronically shunt across a switch or sensor that is being monitored by a normally closed protective loop. It may be set for a 15, 30 or 60 second time delay. The timer may be reset to the initial delay time by depressing the button while the switch is being shunted. The green LED will flash while the switch is shunted. During this time, it is safe to open the switch without going to an alarm condition. If the switch is not closed by the time the LED stops flashing, the system will go into an alarm mode.

The GRI SB-2000 comes in two versions: a recessed version designed to fit inside a single gang utility box, and a surface mount version which may easily be mounted to the wall of an existing fixture.

# TIMED ELECTRONIC SHUNT SWITCH

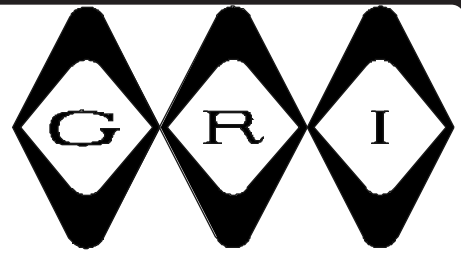

## SB-2000/SB-2001

- ◆ Adjustable Timed Shunt With Indicating LED
  - ◆ Allows Exit Without Disarming System
- ◆ External Power Wiring Required    ◆ Eliminates Need For Codes
  - ◆ Residential & Commercial Applications

### APPLICATION:

The GRI SB-2000 is an electronic add on device that can be incorporated into any existing closed loop circuit. It provides a simple to operate, automatic method of shunting (bypassing) a single or multiple device(s) within that protective loop for a preset amount of time, which may be set by the user. Typical applications for this device include homes and businesses using an alarm system to monitor a door which might need to be opened after the alarm is set. Examples of this are letting the family pet out or having employees leave after hours. Several advantages of the SB-2000 are that there are no codes to learn (or to pass out to others), convenient location of the unit (it may be located near the door to be shunted), and automatic rearming of the system.



### DESCRIPTION:

The GRI SB-2000 is designed to electronically shunt across a switch or sensor that is being monitored by a closed circuit protective loop. The timer may be reset to the initial delay period by depressing the button while the switch is being shunted. The green LED will light while the switch is shunted. During it's last 5 seconds the LED will flash, alerting the user their delay period is almost used. During this time it is safe for the door to remain open without going to an alarm condition. If the door is not closed by the time the LED stops flashing, then the system will go into alarm mode.

The Shunt Switch comes in two versions: a recessed version - SB-2000 designed to fit inside a single gang utility box, and a surface mount version - SB-2001 which may easily be mounted to the wall in an existing structure.

The SB-2000 is powered by an external power supply with optional battery backup.

TABLE 1: JUMPER POSITIONS

JP3			JP1	Shunt Period	JP3			JP1	Shunt Period
3	2	1			3	2	1		
⋮	⋮	⋮	⋮	<b>120 Second</b>	⋮	⋮	⋮	☒	<b>60 Second</b>
⋮	⋮	☒	⋮	<b>105 second</b>	⋮	⋮	☒	☒	<b>45 second</b>
⋮	☒	⋮	⋮	<b>90 second</b>	⋮	☒	⋮	☒	<b>30 second</b>
☒	⋮	⋮	⋮	<b>75 second</b>	☒	⋮	⋮	☒	<b>15 second</b>

Aux output TM1-7 is Grounded when on -400ma max current



# TIMED ELECTRONIC SHUNT SWITCH

## INSTALLATION:

**RECESSED VERSION (SB-2000):** The recessed version of the Shunt Switch is designed to fit in a single gang utility box. Run the wires from the door sensor switch(es) into the utility box. Attach the wires to terminal TM1 pins 2(-) and 7 (+) (See Figure 3). Connect positive side of the control panel to pin 7 and the negative side to pin 2. Using an external 12 volt DC supply, run the wires from the power source to the unit and attach the positive voltage to pin 1 and ground to pin 2 of terminal TM1. If battery backup is desired, install a standard 9 volt battery in the battery holder on the back of the Shunt Switch. The LED will flash twice during power up, and then a third time 5 seconds later indicating a successful diagnostics test. Finally, insert the Shunt Switch into the utility box with the button toward the bottom and the LED toward the top. Secure wall plate with the two screws provided.

**SURFACE MOUNT VERSION (SB-2001):** Remove the Shunt Switch from the surface mount case. A knockout is provided on the back of the case for wire access. Attach the surface mount case directly to the wall, or it may be mounted to cover a single gang electrical box. Attach the door switch wires to terminal TM1 pins 2(-) and 7(+) (See Figure 3). Connect positive side of the control panel to pin 7 and the negative side to pin 2. Using an external 12 volt DC supply, run the wires from the power source to the alarm unit and attach the positive voltage to pin 1 and ground to pin 2 of terminal TM1. If battery backup is desired, connect a standard 9 volt battery to the battery connector. The LED will flash twice during power up, and then a third time 5 seconds later indicating a successful diagnostics test. Lay the battery in the bottom of the case and reassemble the Shunt Switch with the button toward the bottom of the case and the LED toward the top. Secure face plate with the two screws provided.

**SETTING SHUNT TIME:** Set the duration of the shunt by moving the black jumper to the position(s) desired corresponding to number of seconds preferred (See Table 1). Each time jumper(s) are moved, reprogramming will require a power down and a power up to complete reprogramming. Loss or removal of power without repositioning of jumper(s) will maintain unit at original setting upon power up. Repositioning jumper(s) without power down and power up steps will not change original time settings until first power off and power up is accomplished. To power down, disconnect battery and/or external power source. To power up, reconnect battery and/or external power source.

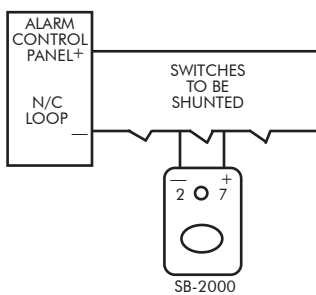

Figure 1. Wiring Diagram

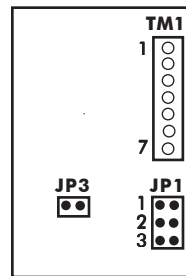

Figure 2. Terminal Connections & Jumpers

Terminal TM1	PIN
External Power (+)	1
Ground (-)	2
Not used	3
Remote Reset/ Delay Switch	4
Not used	5
Not used	6
Door Switch (+)	7

JP3 See Jumper Options

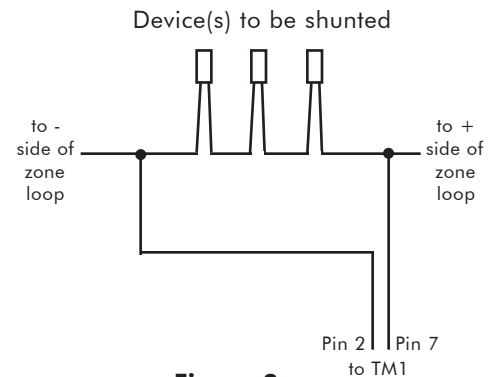

Figure 3.

**WARRANTY:** One year warranty against workmanship, material and factory defects.



MADE IN U.S.A.