

NOTES:

1. 1/2 ϕ MOUNTING HARDWARE IS RECOMMENDED, STUD-ANCHOR-500 OR L-BOLT-500.
2. COATED IN 2-4 MILS ANODIZED ALUMINUM COLOR POWDER COATING.
3. *ANODIZED COATING NOT AVAILABLE.



PEDESTALPRO.COM
1-800-660-3072

UNLESS OTHERWISE SPECIFIED:

DIMENSIONS ARE IN INCHES
TOLERANCES:
FRACTIONAL $\pm 1/32$
ANGULAR: $\pm 2^\circ$
TWO PLACE DECIMAL ± 0.010
THREE PLACE DECIMAL ± 0.005

INTERPRET GEOMETRIC
TOLERANCING PER:
ASME Y14.5 -2009

NAME	DATE
DRAWN	
CHECKED	

PROPRIETARY AND CONFIDENTIAL
THE INFORMATION CONTAINED IN THIS DRAWING IS THE SOLE PROPERTY OF PEDESTALPRO LLC. ANY REPRODUCTION IN PART OR AS A WHOLE WITHOUT THE WRITTEN PERMISSION OF PEDESTALPRO LLC IS PROHIBITED.

TITLE:
INSTALLATION

Friday, May 29, 2020
9:11:32 AM

WEIGHT: 9.643

SIZE	PART NO.	REV
A	44TOW-PRO-001-ALU	0
NO SCALE		SHEET 1 OF 7

ITEM NO.	PART NUMBER	DESCRIPTION	QTY.
1	44TOW-PRO-001-ALU TUBE	6061 ALUM BODY	1
2	PLACAP-4-4-ALU	4 X 4 ALUM CAP PLATE	1
3	PLTACC-310	4" STND 304 SS ACCESS PANEL	1
4	PLTBAS-4-4-ALU	4" STANDARD ALUM BASE PLATE	1
5	--	8-32 PAN HEAD SCREW	4

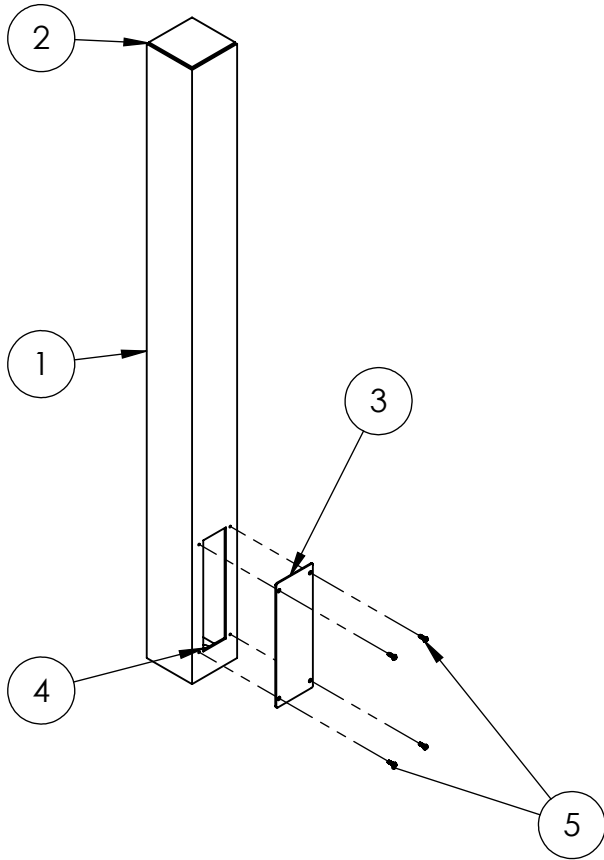

NOTES:

1. SEE STANDARD PREPARATION AND COATING INSTRUCTIONS FOR COATING PROCEDURE AND COLOR.
2. SEE STANDARD PACKAGING INSTRUCTIONS FOR PACKAGING PROCEDURE.



PEDESTALPRO.COM
1-800-660-3072

UNLESS OTHERWISE SPECIFIED:

DIMENSIONS ARE IN INCHES
TOLERANCES:
FRACTIONAL $\pm 1/32$
ANGULAR: $\pm 2^\circ$
TWO PLACE DECIMAL ± 0.010
THREE PLACE DECIMAL ± 0.005

INTERPRET GEOMETRIC
TOLERANCING PER:
ASME Y14.5 -2009

NAME	DATE
DRAWN	
CHECKED	

PROPRIETARY AND CONFIDENTIAL

THE INFORMATION CONTAINED IN THIS DRAWING IS THE SOLE PROPERTY OF PEDESTALPRO LLC. ANY REPRODUCTION IN PART OR AS A WHOLE WITHOUT THE WRITTEN PERMISSION OF PEDESTALPRO LLC IS PROHIBITED.

TITLE:
ASSEMBLY

Friday, May 29, 2020
9:11:32 AM

WEIGHT: 9.643

SIZE	PART NO.	REV
A	44TOW-PRO-001-ALU	0

NO SCALE

SHEET 2 OF 7