

ODM-2015\_PS\_240212

# ODM-2015 Overview & Specifications

The ODM-2015 is an OSDP Multiplexer or credential splitter that connects an OSDP reader with access control systems; one OSDP system and one Wiegand system. Credential data from the OSDP reader is routed to both access control systems. PD Port 1 connects to the Primary OSDP access controller, which has full control over the OSDP reader (send I/O messages such as LED and buzzer commands). The Wiegand Output Port connects to the Secondary Wiegand access controller, which only receives credential data.

Three LEDs indicate the status of the two OSDP connections and Wiegand output. Relay 1 is used to supervise the OSDP communication between the ODM-2015 and Primary access controller. Relay 2 is used to supervise the OSDP communication between OSDP reader and the ODM-2015. There are two digital I/O pins that normally do not have any function, but can be assigned functions in custom applications.

Specifications			
Part Number	Part Number	ODM-2015	
	UPC	816684005329	
Physical	Physical Dimensions (L x W x H)	4.50 x 2.85 x 0.94 inches   114.30 x 7.24 x 2.39 cm	
	OSDP Ports	2 OSDP Ports   1 ACU Port (Reader) and 1 Port (Access Controller)	
	Wiegand Port	1 Wiegand Output Port	
Environmental	Operating Temperature Range	-40°F to 158°F   -40°C to 70°C	
	Enclosure Rating	Not rated for water or dust intrusion.	
Electrical	Supply Voltage	8 - 16 Vdc @ 300 mA	
	Relays	Max Switching	220Vdc 30W (resistive) 1A / 250Vac 37.5VA 1A
		Running Spec with load	30Vdc 1A (resistive) / 125 Vac 0.3A (resistive), 1x10 <sup>5</sup> operations @ 20°C
LED Indicators	ACU Port LED (P0)	Indicates status of ACU Port (No Communication, Clear Channel Session, Secure Channel Session, Reader data)	
	PD Port LED (P1)	Indicates status of PD Port (No Communication, Clear Channel Session, Secure Channel Session, Reader data)	
	Wiegand Port LED (P3)	Indicates when data is output form the Wiegand port.	

# ODM-2015 Connections & LEDs

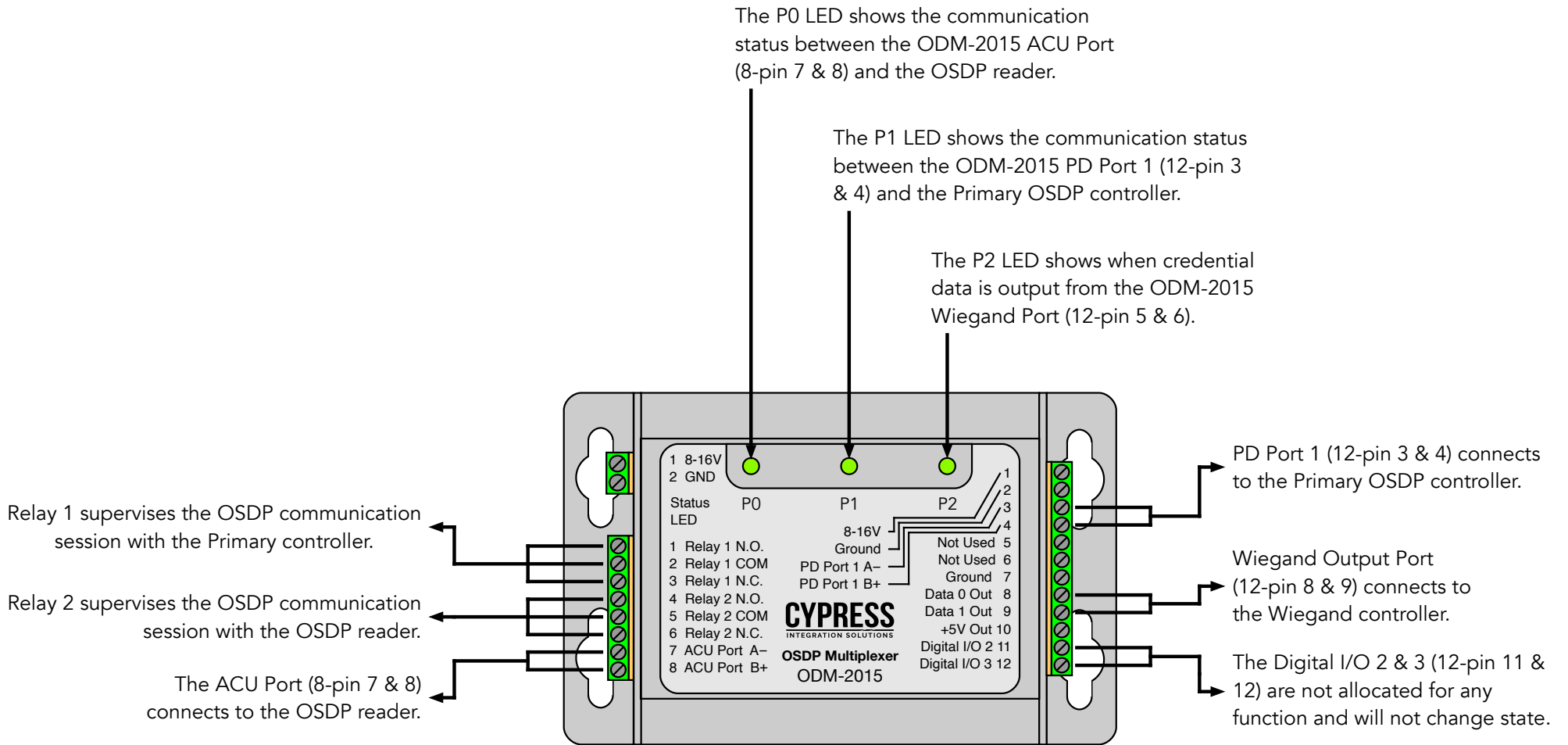

# ODM-2015 Wiring Diagram

