

MM400

ITEM NO.	PART NUMBER	DESCRIPTION	Material	QTY.
1	75002	15lb.(66N), 10-24 Female Thread, Ø1.2" X .25" Thick Rubber Coated Magnet Assembly	Magnet-N35 NdFeB Rubber-Black TPR	4
2	922572952	10-24 X 5/16" Phillips 100° Flat Head Screw	18-8 Stainless Steel	4

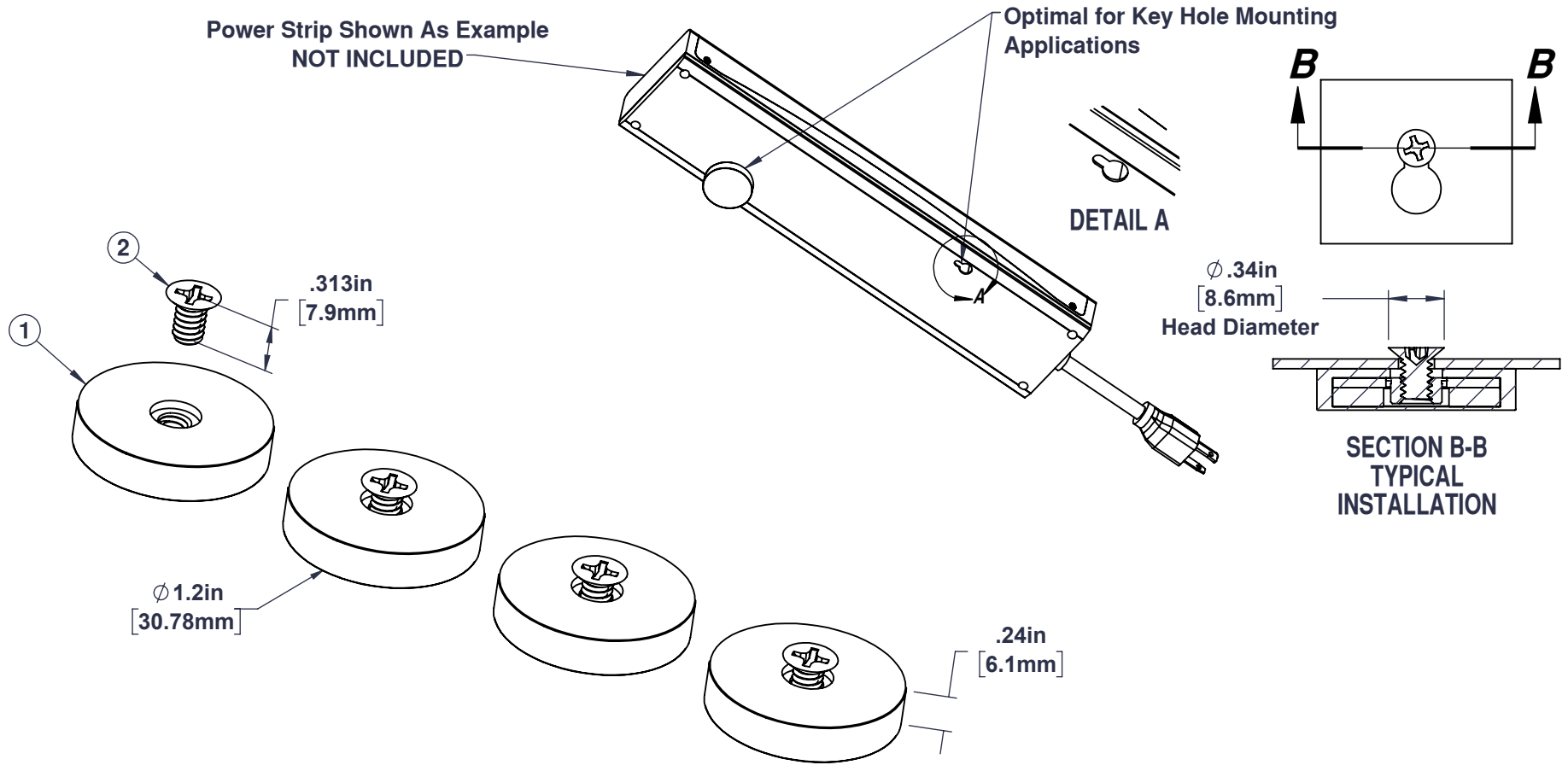

OPERATING TEMPERATURE --40° - 176° F (-40° - 80°C)

Please read before use! Disclaimer: Mag Daddy neither assumes nor accepts any liability for damages resulting from the handling or use of magnets. With your purchase, the buyer confirms that you have read and understand the following warnings: the buyer agrees that he/she is responsible for all damages/injuries caused by the magnets, which includes personal injuries, property damages or magnet damages. The buyer must agree with the terms before purchase. Pull forces we have provided are estimates only, we are not responsible for any inaccuracy of the magnet pull force. *Please test the pull force before any usage.* Magnets are very strong. Handling them with care is necessary to prevent personal injuries, property damages and magnet damages.
CAN BE HARMFUL TO PACEMAKER WEARERS and others with MEDICAL IMPLANTS.

CONFIDENTIAL: USE OF THIS DRAWING WITHOUT WRITTEN AUTHORIZATION BY MAG-DADDY, LLC IS PROHIBITED		INCH <input checked="" type="checkbox"/> SCALE: 1:1	Sheet Size: A
GENERAL TOLERANCE: UNLESS OTHERWISE SPECIFIED: ± .020 (.51mm)		THIRD ANGLE PROJECTION	 295 Jamie Ln. Wauconda, IL 60084 www.magdaddyusa.com PH:(847) 719-5600
ANGLES: ± 5°		Rev. 00	
MATERIAL: SEE BOM	PART DESCRIPTION: MAGNETIC RUBBER KEYHOLE MOUNTING KIT 4 (15LB) MOUNT MAGNETS, Ø.34"(8.6mm) HEAD DIAMETER HARDWARE	PART NO. MM400	

LAST PRINT DATE: 12/16/2024