

# Surface Mount Water Contact

WWW.GRISK.COM



- ◆ Will detect any conductive non-flammable liquid
- ◆ Ideal anywhere water damage could occur
  - ◆ Automatic reset
  - ◆ 6 foot jacketed lead standard
  - ◆ Custom lead length available
- ◆ For maximum protection we recommend using the 2600 4-wire sensor



Undetected water damage, such as that caused by leaking pipes or corroded water heaters, cost homeowners tens of thousands of dollars each year. Such repairs are time consuming and costly to correct. Applications could include computer room sub-floor areas, telephone equipment rooms, bathrooms, laundry rooms, any areas adjacent to a water storage tank or piping. Also evaporative air conditioners, drip pans, overflows and/or drains.

Using no mechanical parts, the GRI Water Sensors are triggered by a moisture bridge across the sensor contacts. The GRI Water Sensors can be installed to detect a layer of water a minute as 1/16 of an inch in depth.

Requiring only two wires for signal and power, the GRI 2800 Water Sensor utilizes an open collector electronic trigger. The sensor stimulates a simple dry closure. It can be used to activate a remote signaling device or it can be wired directly to most alarm panels and some wireless transmitters.

The GRI Water Sensors will continue to protect against troublesome and costly water leaks for years to come.

## Part Numbers

### **Configuration**

**2800** Normally Open for an open loop circuit  
5-24 Volts DC

## 2800 Open Loop Specifications

### **Power Requirements:**

Operating Voltage (min./max.)	5-24 Volts DC
Standby Current (at max. voltage)	10 uA
Alarm Current (max.)	400 mA

### **Wire Contacts:**

Red Wire	+5-24 Volts DC
Black Wire	- Ground

### **Contact Characteristics:**

Contacts	Normally Open
----------	---------------

**WARRANTY:** One year warranty against workmanship, material and factory defects.

GEORGE RISK INDUSTRIES, INC.  
G.R.I. PLAZA  
KIMBALL, NE 69145

WWW.GRISK.COM



1-800-445-5218  
1-800-523-1227  
(308) 235-4645  
FAX (308) 235-3561  
E-MAIL: sales@grisk.com

# Surface Mount Water Contact

WWW.GRISK.COM



## INSTALLATION INSTRUCTIONS:

### MINIMUM 5 VDC REQUIRED

*THIS IS AN EXTREMELY IMPORTANT TECHNICAL ADVISORY FROM GRI: If there is insufficient power to properly operate this device, the ability of the security system to sense the presence of water will be compromised.* The 2800 is a normally open switch for an open loop application. The 2800 requires a DC operating voltage on the zone loop of a 5VDC minimum to a maximum 24VDC. If there is an EOL resistor installed, measure to confirm the 5 VDC minimum for the zone loop. (In the even the panel does not provide the minimum DC voltage, refer to the drawing at the right for installation.) After installation, these units should be tested with a damp sponge or paper towel and inspected annually. If there is any corrosion or damage the sensor should be replaced.

### FOR INSTALLATION TO THE CONTROL PANEL

Select the open loop where the switch will be connected. The switch must be connected with the correct polarity. If the panel terminal strip is not marked, zone polarity can be determined by using a test volt meter. The panel must be capable of producing a minimum of 5 Volts DC under load to the sensor. Connect the red lead to the positive side of the panel zone and the black lead to the returning negative side. (If the panel does not provide minimum power for the 2800 use the wiring diagram at the right showing the use of a sensitive relay board and the auxiliary power from the BACP.)

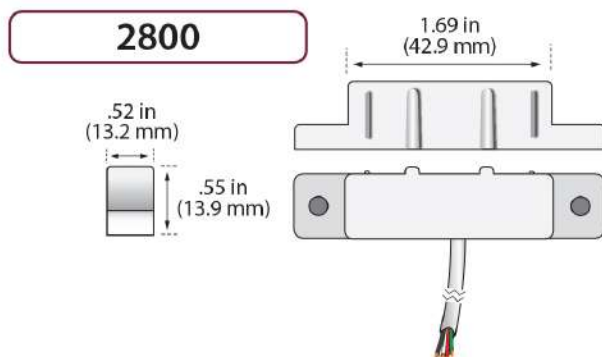
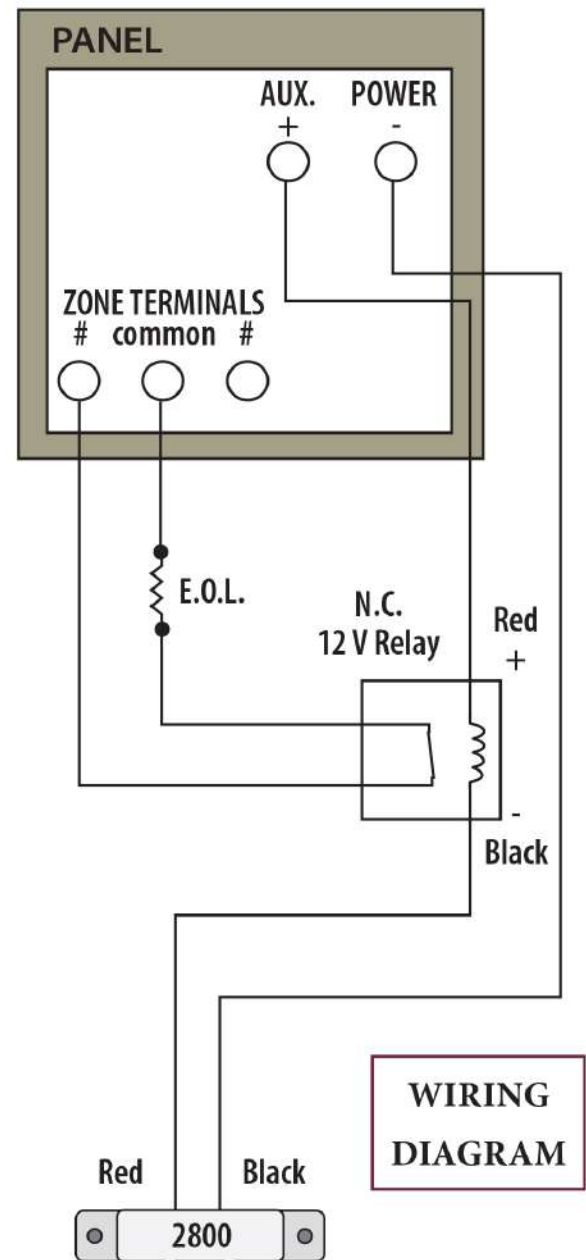

**WARRANTY:** One year warranty against workmanship, material and factory defects.

GEORGE RISK INDUSTRIES, INC.  
G.R.I. PLAZA  
KIMBALL, NE 69145

WWW.GRISK.COM



1-800-445-5218  
1-800-523-1227  
(308) 235-4645  
FAX (308) 235-3561  
E-MAIL: sales@grisk.com