

SAFETY INFORMATION

1. Never install wiring or components during a lightning storm.
2. Never install components in wet locations unless the components are designed specifically for use in wet locations.
3. Never touch uninsulated wires or terminals unless the wiring has been disconnected at the network interface.
4. Use caution when installing or modifying wiring or components.



Invest in Solid Engineering

VCM5-FR, VCM5-FO
5" Vertical Cable Management & Accessories

Installation Instructions



**Thank you
for your
business!**

*weRack
your
World!*TM

WeRackYourWorld.com

1.866.TRY.GLCC (879-4522)

5" VERTICAL CABLE ORGANIZER

General Installation Tips

1. Mount bottom section first and use as support when mounting top section.
2. #12-24 screws are included for mounting. This product is also compatible with screw size #10-32 and M6.
3. Due to the length of the channel fingers, an extra long screwdriver adapter can be used to facilitate the mounting of horizontal products (patch panels and cable management) after the channel has been installed.

Installation

VCM5-FR - Vertical Front & Rear Cable Management, 5" Channel x 80"L, and black snap-on cover; 4 mounting brackets and package of #12-24 screws included

VCM5-FO - Vertical Front Cable Management, 5" Channel x 80"L, and black snap-on cover; 4 mounting brackets and package of #12-24 screws included

1. Align the channel mounting brackets with the equipment rack (Figure 1).
2. To secure the channel in place, push the supplied #12 screws through the mounting bracket and screw into the equipment rack.
3. When assembling the 80" channel, carefully align the connecting tabs (Figure 2).
4. To install the cover(s), fit the cover over one side of duct fingers and rotate the cover to the other side until it snaps into place.

NOTE: The channel fingers can be bent outward and snapped off to more easily run cables from the vertical to the horizontal channel.

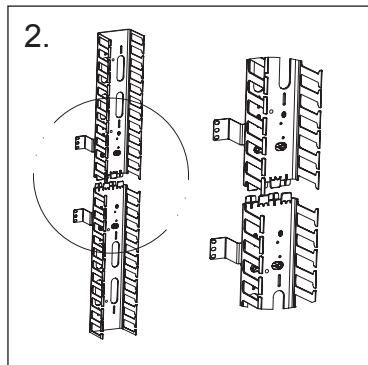
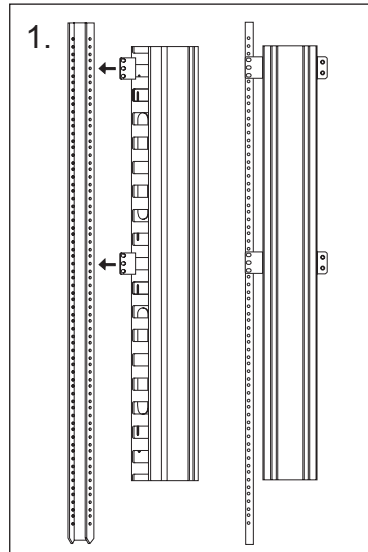

5" ACCESSORIES

Slack Spool VCM5-SL

The Slack Loop Storage Organizer manages and stores excess cable for future use. The Organizer is moveable and can be installed to accommodate different size slack loops.

1. Slide the Slack Loop Storage Organizer over the fingers of the Vertical Slotted Duct (Figure 3).

NOTE: Bend radius and Slack Loop Storage Organizer are compliant with ANSI/TIA/EIA standards.

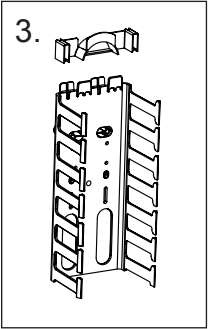

Cable Retainer VCM5-CR

The Cable Retainer is designed to hold cable within the channel. The Cable Retainer has four notches, so it can be snapped off to accommodate different size slotted ducts.

1. Slide the Cable Retainer over the channel finger until it snaps into place (Figure 4).

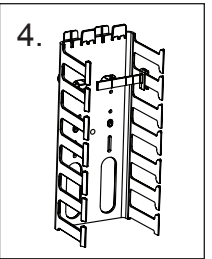

Cover Hinge VCM5-HNG (optional)

The Cover Hinge is designed to easily open and close cover for increased protection and easy access.

1. Attach cover first. Snap hinge between slotted fingers and attach to one side of cover (Figure 5).

NOTE: Use a minimum of two hinges per cover.

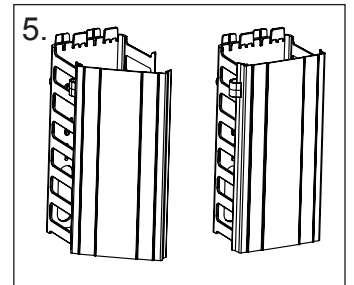

Mounting Bracket VCM5-BKT

The Mounting Bracket is designed to assist in attaching the vertical duct to an adjacent equipment rack. The Mounting Bracket Kit comes with #8 screws (Figure 6).

