

CM-SRX2 Wireless 2 Channel Receiver

INSTALLATION INSTRUCTIONS



THIS PACKAGE INCLUDES:

- 1 - CM-SRX2 Receiver
- 1 - Grommet
- 4 - Anchors
- (Parts are inside the Receiver Case.)
- 4 - Self Tapping Screws

1. GENERAL DESCRIPTION

The CM-SRX2 is a standalone receiver that allows access control up to two doors from one device. Ideal for front desk/reception applications or hard-to-wire locations. Designed to work with magnetic locks, electric strikes, keypads, gate operators and door operators. Kits include channel receiver and transmitter.

- Relay 1 for Door Strikes, Relay 2 for Maglocks
- The receiver can be mounted indoors or outdoors. IP65-rated
- Rolling code encryption
- Field configurable latching/bi-stable mode keeps doors unlocked until button is pressed again
- Receiver can be controlled by up to 30 transmitters
- Receiver relay mode is either momentary or bi-stable for 2nd relay

3. DIMENSIONS

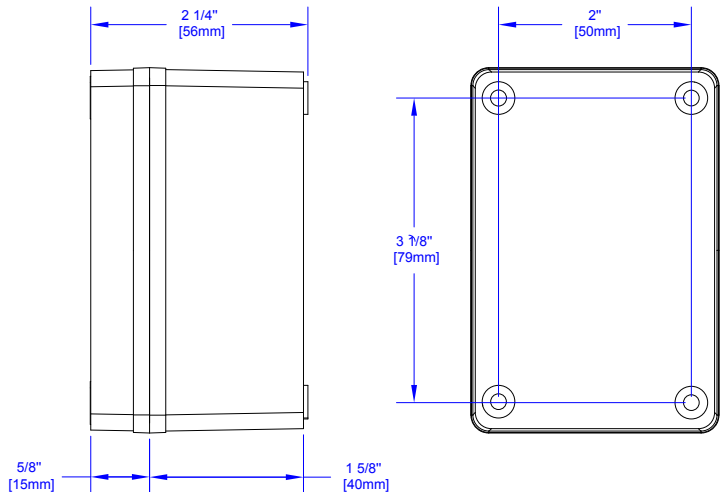
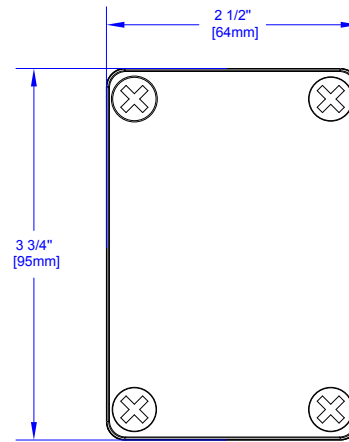

2. SPECIFICATIONS

Input Power	12V or 24V AC/DC
Standby Current	18mA (Input VDC12V)
Operating Current	80mA (Input VDC12V)
Working Humidity	0-95%
Working Temperature	-20°C to 85°C (-4°F to 185°F)
Lock Relay	1A @ 30VDC
Memory	30 codes
Encryption	Rolling code
Number of Relays	2 SPST; 1 ST relay momentary, 2 ND momentary or latching/bi-stable, 1A@30VDC
Frequency	868.35 MHz
IP Rating	65 with grommet
Dimensions	2-1/2" W x 3-3/4" H x 2-1/4" D (64mm x 95mm x 56mm)

4. INSTALLATION AND WIRING

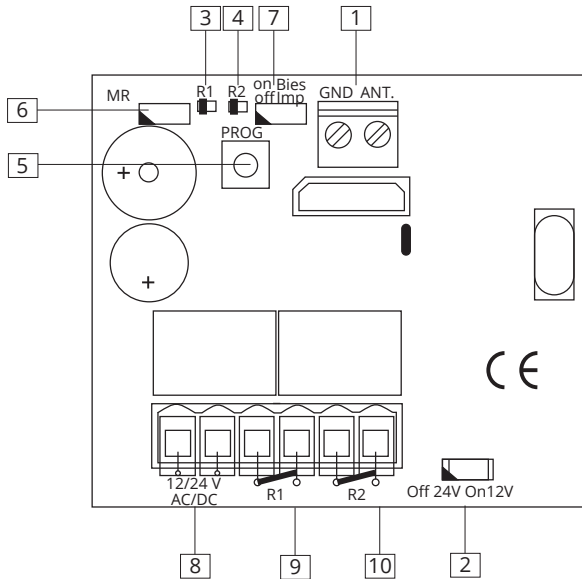

- 1. Antenna Connection
- 2. Jumper 12/24V
- 3. Channel 1 Operation LED
- 4. Channel 2 Operation LED
- 5. Programming Push Button
- 6. Jumper Reset
- 7. Microswitch Impulse/ Bi-Stable
- 8. Power Supply
- 9. Relay 1 Output
- 10. Relay 2 Output

Note: Installation parts are inside the Receiver Case.

Attach the rear part of the housing to the wall using the plugs and screws supplied. Pass the cables through the hole of the receiver. Connect the power cables to the 12/24V terminals marked on the PCB board as indicated. (Left terminal is positive) Seal and cover the receiver front cover to the base using the screws supplied.

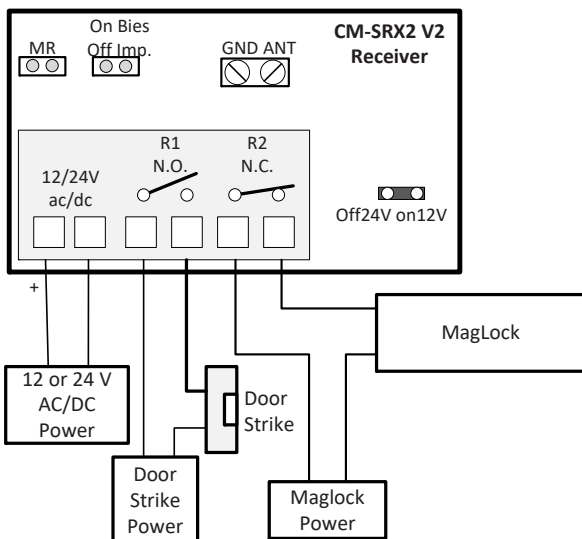

5. OPERATION

The two red LED lights flash every 5 seconds to confirm power is applied to the receiver. Upon receiving a code, the receiver checks whether it is in its memory, activating the corresponding relay. The relay activation mode is selected in either impulse or ON/OFF using the **Imp/Bies** jumper. Only relay 2 can have its mode changed by this jumper from impulse to bi-stable. Imp (Impulse) = When you press and release the button on the transmitter, the relay will trigger for no less than one second. If you press and hold the transmitter button, the relay will trigger on for no more than five seconds before releasing. Bies (Bi-Stable) = The relay will latch on when the transmitter button is pressed and released the first time. The relay will latch off when the transmitter button is pressed and released the second time. Changing the mode for relay 1 can only be accomplished at the factory. (Contact sales for details.)

4. PROGRAMMING

Manual programming

Press the receiver programming button for 1 sec. and an acoustic signal will be heard. The receiver will enter programming (see table below). If the receiver programming button is held pressed down, the receiver will sequentially go from one configuration to the next. Once the programming configuration for the transmitter to be registered has been chosen, send the code to be programmed by pressing the respective transmitter button (1 or 2). Every time a transmitter is programmed, the receiver will issue an acoustic signal for 0.5 seconds for confirmation. After 10 seconds without programming or pressing the first two transmitter buttons, the receiver will automatically exit programming mode while beeping one second twice. If upon programming a transmitter the receiver memory is full, the receiver will emit 7 beeps of 0.5 seconds and exit programming.

The receiver is always configured in multi-channel.

Configuration of Transmitter Programming in the Receiver	LED R1	LED R2
The 1st relay is activated by channel 1 and the 2nd relay by channel 2	Flashing	Flashing
Special Programming		
Press the transmitter channel to activate the relay 1 on the receiver	ON	OFF
Press the transmitter channel to activate the relay 2 on the receiver	OFF	ON
Press the transmitter channel to activate the two relays at once *	ON	ON

* If working in latching/bi-stable ON/OFF activation mode, relay 1 will act as impulse and relay 2 as ON/OFF. Therefore, on the first press relay 1 will close and open the contact and relay 2 will only close. On the second, relay 1 will close and open the contact and relay 2 will open.

NOTE: Each transmitter can be configured independently on the receiver.

Total Reset

In programming mode, press the programming button down and simultaneously short the “MR” jumper for 3 seconds. The receiver will issue 10 short acoustic warning signals followed by others at a faster pace to indicate that the operation has been successful. The receiver is now in programming mode. After 10 seconds without programming or quickly pressing the programming button, the receiver will exit programming mode, issuing two, one second beep signals.

NOTE: This equipment has been tested and found to comply with the limits for a Class B digital device, pursuant to part 15 of the FCC Rules. These limits are designed to provide reasonable protection against harmful interference in a residential installation. This equipment generates, uses and can radiate radio frequency energy and, if not installed and used in accordance with the instructions, may cause harmful interference to radio communications. However, there is no guarantee that interference will not occur in a particular installation. If this equipment does cause harmful interference to radio or television reception, which can be determined by turning the equipment off and on, the user is encouraged to try to correct the interference by one or more of the following measures:

- Reorient or relocate the receiving antenna.
- Increase the separation between the equipment and receiver.
- Connect the equipment into an outlet on a circuit different from that to which the receiver is connected.
- Consult the dealer or an experienced radio/TV technician for help

7. EXPLODED VIEW

