

Features

- Approved for mounting in any matter including dome up
- Synchronize with SSM module
- Current limited
- 10,000 hour strobe tube
- 3/4” NPT pendant, ceiling and wall mount options available
- Dome guard optional
- Type 4X, IP66, IPK69 enclosure
- UL Listed for Class I, Division 1, Groups C and D; Class II, Division 1, Groups E, F and G; Class I, Division 2, Groups A, B; and Class III
- Marine rated



Description

The Federal Signal Model FSEX-HI explosion-proof strobe light produces 80 high-intensity flashes per minute. This warning light operates on 24VDC and is unique to the market because it covers an entire range of possible mounting configurations – including dome up. This light is designed for use in alarm notification systems and is compatible with fire alarm and suppression supervised control panels and power boosters.

The 24VDC FSEX-HI features a voltage in-rush limiting PCB design that provides greater compatibility with factory automation control systems and less electrical interference with in-rush sensitive devices.

The Model FSEX-HI is specifically designed for explosion-proof atmospheres and/or corrosive environments. Because it is easy to install and requires very low maintenance, it is ideal for use in areas such as oil rigs, mines, refineries, and chemical plants

Technical Specifications

Operating Voltage	24 VDC polarized
Operating Current	1.90 amps (3.0 amps in-rush)
Flash Rate Per Minute	80
Candela peak*	2,000,000
Lamp Life	10,000 hours
Light Source	Strobe tube
Material	Cast Aluminum
Operating Temperature Range	-31°F to 150°F
Weight	Without mounting: 13.9 lbs Ceiling mount: 4.5 lbs Pendant mount: 2.0 lbs Wall mount: 5.9 lbs

*Note: Peak candela is the maximum light intensity generated by a flashing light during its light pulse.

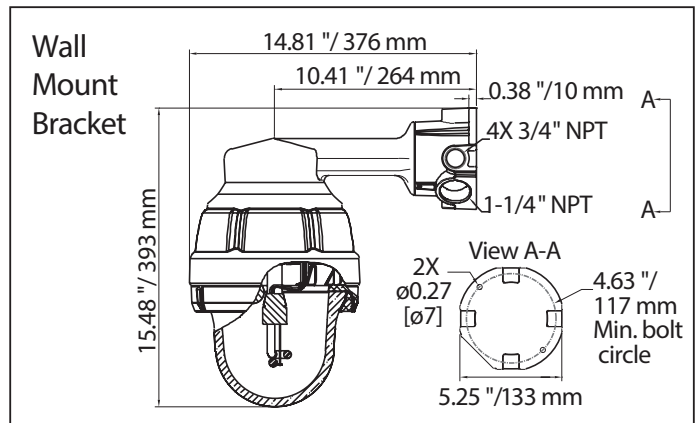
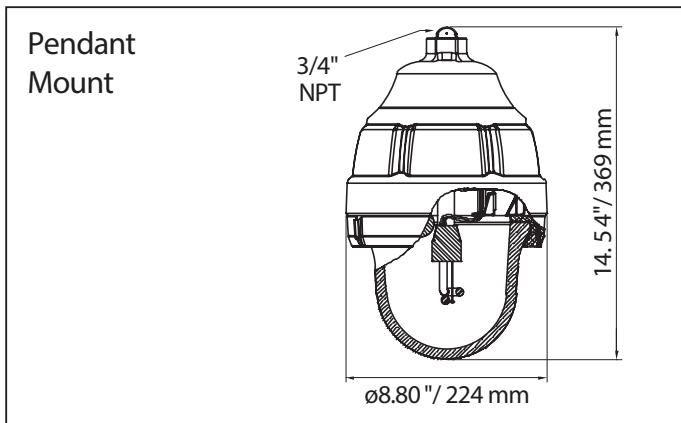
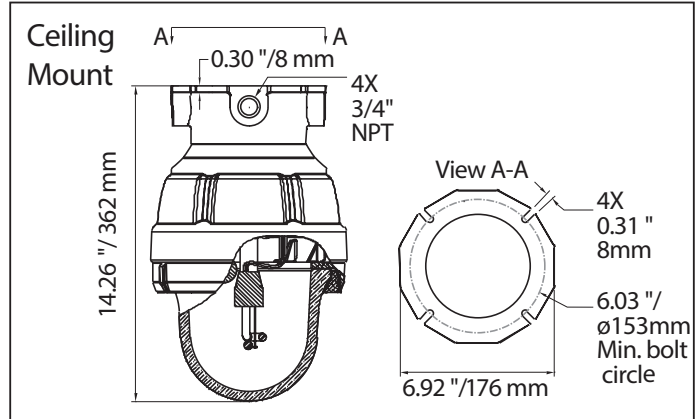
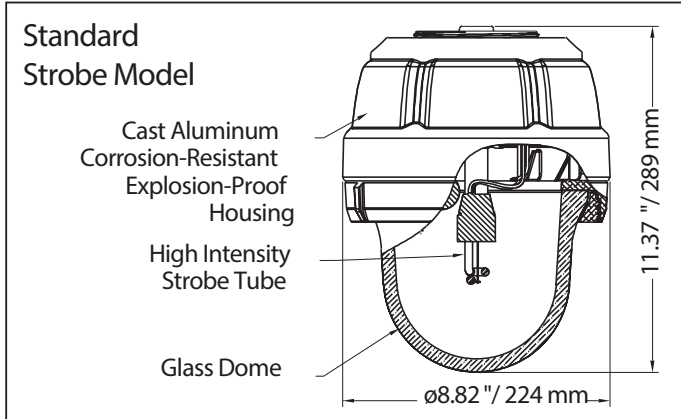

Ordering Information

Part Number	Ordering Part Number	Description
FSEX-CPG-HI-2	1430502	Explosion-Proof Strobe, 16-33 VDC, 1.9A, Red Housing, Clear Lens
DGXC-SB	1430508	Dome Guard
CMXC-R-SB	1400506	Ceiling Mount
WMXC-4R-SB	1420503	90 Degree Wall Mount
LITESFX01A	Call for part number	Strobe Tube (Series A2, B1)
SSM	1430509	Sync Module, 2 Strobes per circuit
PMXC-R-SB	1430507	Pendant Mount

WARNING

- Installation must be performed by qualified personnel and in accordance with all national and local codes and ordinances.
- Shock hazard. Disconnect power source before servicing. Serious injury or death could result.
- Read all instructions carefully and understand them before starting installation. Save instructions for future use. Failure to read and understand instructions could result in improper operation of device resulting in serious injury or death.

Hazardous Locations

Class	Group	Division	40°C	65°C
I	A, B	2	T2B	T2A
I	C, D	1 & 2	T6	T4A
II	E, F, G	1 & 2	T6	T4A
III		1 & 2	T6	T4A