



Safety Technology International

2306 Airport Road
Waterford • Michigan • 48327-1209
Phone: 248-673-9898
E-mail: info@sti-usa.com • Web: www.sti-usa.com

Taylor House • 34 Sherwood Road • Bromsgrove
Worcestershire • B60 3DR • England
Tel: +44 (0)1527 520 999
E-mail: info@sti-emea.com • Web: www.sti-emea.com

Unit 7A • Lockheed Avenue
Airport Business Park
Waterford • X91 HWF2 • Ireland
E-mail: info@sti-emea.com

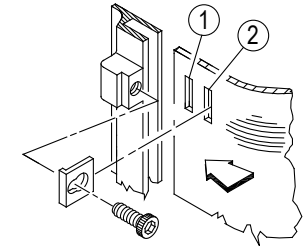
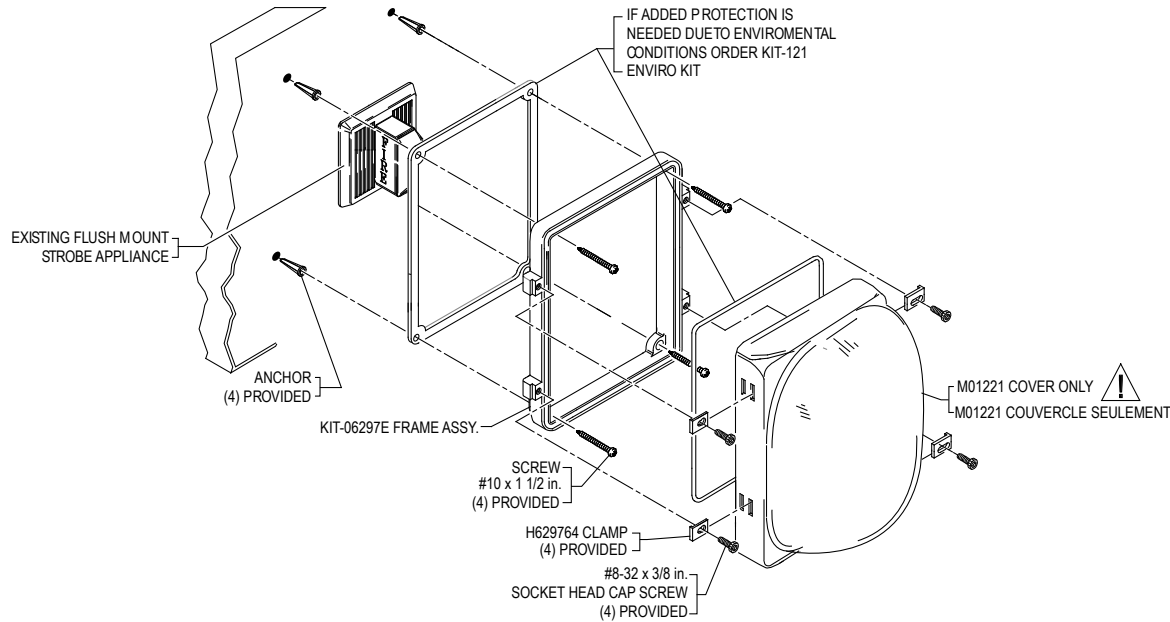

INSTALL CLAMP IN NOTCH 2 AS SHOWN

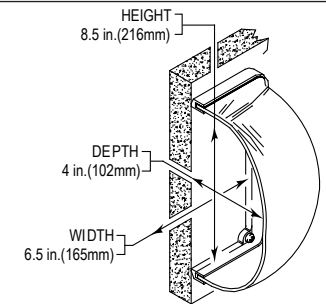

INTERNAL DIMENSIONS

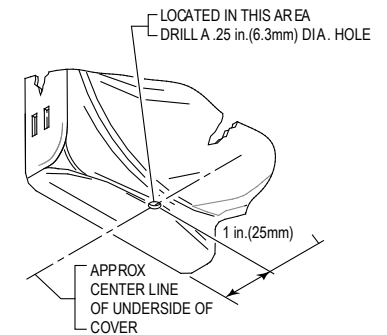

WEEP HOLE INSTALLATION



INSTALLATION NOTES

- To minimize strobe light loss, regardless of the type of strobe appliance used, center cover over the strobe light lens. Failure to follow these instructions may lead to light loss transmission.
- Damage Stopper must be installed to comply with applicable NEC, NFPA and local codes.
- In applications where wash downs, rainfall or condensation occur, it is recommended that a drain or weep hole be provided. Refer to weep hole installation diagram.
- Damage Stopper may be installed outdoors when appliance carries an outdoor rating.

REMARQUES SUR L'INSTALLATION

- Afin de minimiser la perte de lumière stroboscopique, quel que soit le type de stroboscope utilisé, le couvercle doit être centré sur l'objectif stroboscopique. Le fait d'omettre ces instructions risque d'entraîner la perte de diffusion de la lumière.
- Le Stopper de dégâts doit être installé de sorte à être conforme avec les normes NEC, NFPA applicables et les codes locaux.
- Dans les applications où des jets d'eau, des précipitations ou de la condensation se produisent, il est recommandé de prévoir un trou de vidange ou une barbacane. Reportez-vous à schéma d'installation d'une barbacane.
- Il est possible d'installer un Stopper de dégâts à l'extérieur lorsque l'appareil est homologué pour utilisation à l'extérieur.

INSTALLATION INSTRUCTIONS - REFER TO EXPLODED VIEW

- Using back box assembly as a template, place against mounting surface at proper location according to NFPA 72.
- Mark and drill (4) holes 1/4 in. (6.3mm) diameter, 1 in. (25mm) deep.
- Insert the (4) anchors into the wall.
- Mount frame assembly to wall with screws.
- Install electrical fittings as needed.
- Install strobe appliance (except for retrofit applications).
- Install cover with clips and screws.
- Test appliance according to appliance manufacturer's instructions.

CLEANING INSTRUCTIONS

Rinse with water to remove abrasive dust and dirt. Wash with soap or mild detergent, using a soft cloth (do not scrub). Rinse once more then dry with a soft cloth or chamois. To remove grease or wet paint, rub gently with a cloth wetted with naphtha. Then wash and rinse. DO NOT USE RAZOR BLADES.



WARNING: This product can expose you to chemicals including Dichloromethane, which is known to the State of California to cause cancer, and Bisphenol A (BPA), which is known to the State of California to cause birth defects or other reproductive harm.

For more information go to www.P65Warnings.ca.gov.

Three year warranty or a one year limited warranty (from date of purchase) on most products. See website for details. Electronic warranty form at www.sti-usa.com/wc14.

STI-1221E STROBE DAMAGE STOPPER®

All specifications and information shown were current as of publication and are subject to change without notice.

1221EIS APRIL2006



USA



EMEA

