

ENERGIZER CR1616

Lithium Coin



Industry Standard Dimensions

mm (inches)



This Battery has Underwriters Laboratories component Recognition

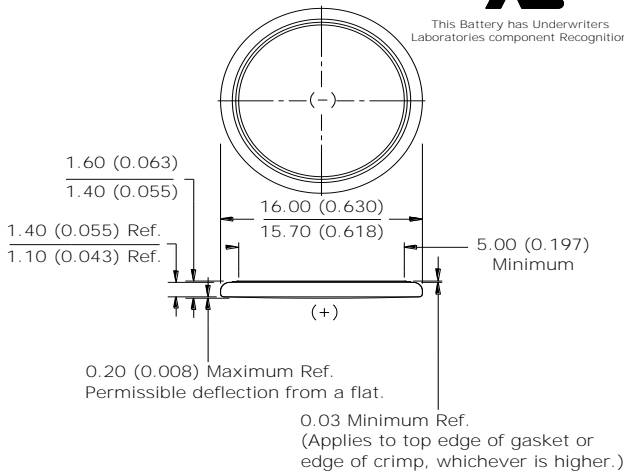

Simulated Application test

Typical Performance at 21°C (70°F)

Schedule:	Typical Drains: at 2.9V (mA)	Load (ohms)	Cutoff 2.0V (hours)
Continuous	0.097	30,000	567

Typical Discharge Characteristics

Load: 30K ohms - Continuous
Typical Drain @ 2.9V: 0.097 mA

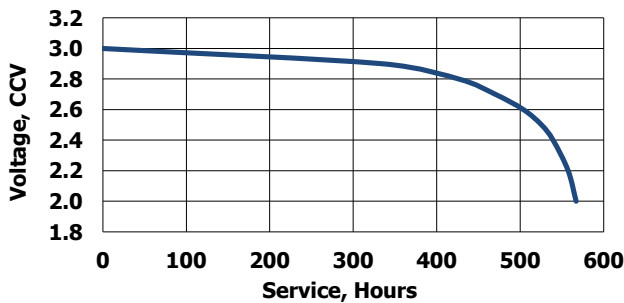

Internal Resistance Characteristics

Pulse Test at 21°C (70°F)

Bkgnd Drain: Continuous
30K ohms
0.097 mA @2.9V

Pulse Drain: 2 seconds X 12 times/day
400 ohms
6.6 mA @2.65V

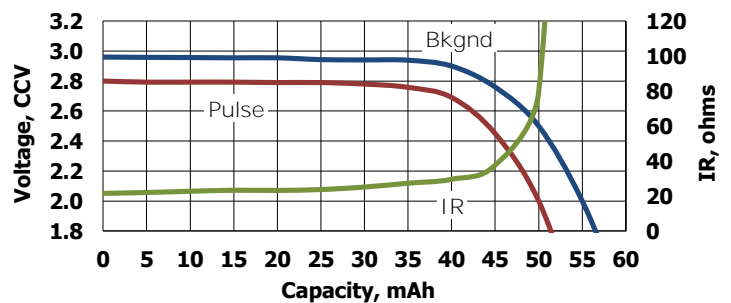

Important Notice

This datasheet contains typical information specific to products manufactured at the time of its publication.
©Energizer Holdings, Inc. - Contents herein do not constitute a warranty.

- Classification:** "Lithium Coin"
- Chemical System:** Lithium / Manganese Dioxide (Li/MnO₂)
- Designation:** IEC-CR1616
- Nominal Voltage:** 3.0 Volts
- Typical Capacity:** 55 mAh (to 2.0 volts)
(Rated at 30K ohms at 21°C)
- Typical Weight:** 1.1 grams (0.04 oz.)
- Typical Volume:** 0.32 cubic centimeters (0.02 cubic inch)
- Max Rev Charge:** 1 microampere
- Energy Density:** 133 milliwatt hr/g, 498 milliwatt hr/cc
- Typical Li Content:** 0.014 grams (0.0005 oz.)
- UL Recognized:** MH29980
- Operating Temp:** -30C to 70C
- Self Discharge:** ~1% / year

Safety:



(1) KEEP OUT OF REACH OF CHILDREN. Swallowing may lead to serious injury or death in as little as 2 hours due to chemical burns and potential perforation of the esophagus. **Immediately see doctor; have doctor phone (202) 625-3333.**

(2) Battery compartment design. To prevent children from removing batteries, battery compartments should be designed with one of the following methods: a) a tool such as screwdriver or coin is required to open battery compartment or b) the battery compartment door/cover requires the application of a minimum of two independent and simultaneous movements of the securing mechanism to open by hand. Screws should remain captive with the battery door or cover.