

## Passive Installation Subwoofers

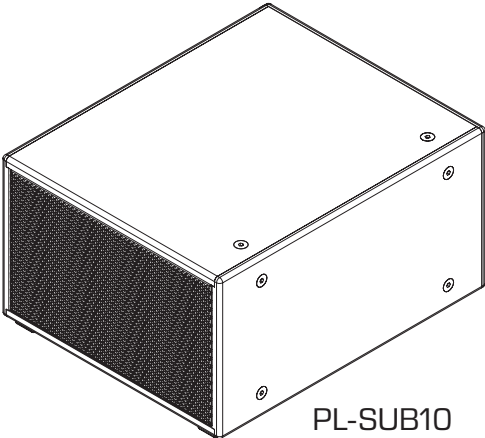

PL-SUB10

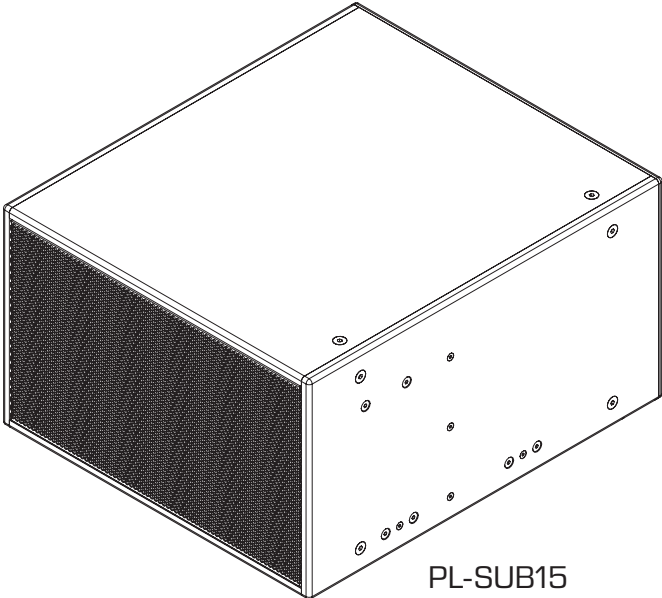

PL-SUB15

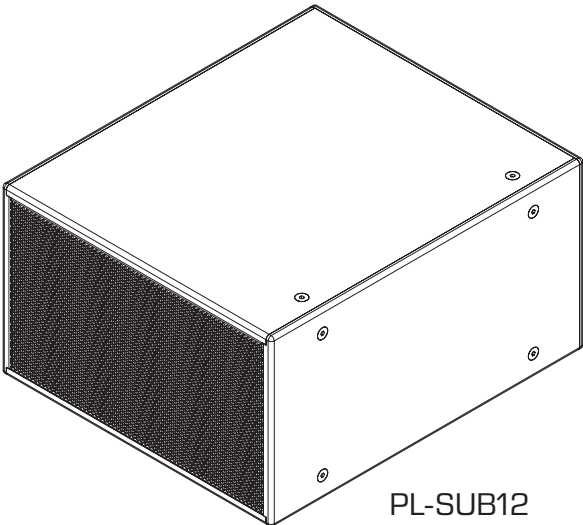

PL-SUB12

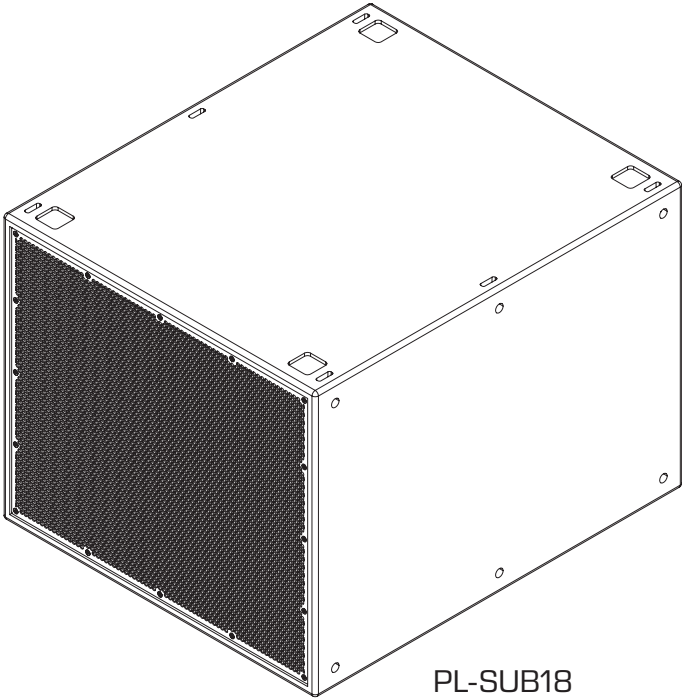

PL-SUB18



# Contents

<b>Explanation Of Symbols</b> .....	<b>4</b>
<b>Important Safety Instructions</b> .....	<b>4</b>
RoHS Statements .....	5
Safety Regulations and Protection Ratings .....	5
<b>Warranty</b> .....	<b>5</b>
General Rules for Suspension .....	6
<b>Shock Loading</b> .....	<b>6</b>
<b>Introduction</b> .....	<b>7</b>
Key Features and Technologies .....	7
Outdoor Deployment .....	7
<b>What's in the Box</b> .....	<b>8</b>
PL-SUB10 Subwoofer .....	8
PL-SUB12 Subwoofer .....	8
PL-SUB15 Subwoofer .....	9
PL-SUB18 Subwoofer .....	9
Accessories (Available Separately) .....	9
<b>PL-SUB10 / PL-SUB12 Features</b> .....	<b>10</b>
<b>PL-SUB15 Features</b> .....	<b>11</b>
<b>PL-SUB18 Features</b> .....	<b>12</b>
PL-LA12-AF Array Frame .....	12
<b>Mounting Option and Deployment</b> .....	<b>13</b>
<b>PL-SUB15 / PL-SUB18 Cardioid Configuration</b> .....	<b>13</b>
Back-to-back .....	13
Stacked .....	13
Side by Side .....	13
Three-Box Cardioid Systems .....	14
Cable Management and Fake Grille (PL-SUB18 Only) .....	14
Stacking Two PL-SUB18 .....	15
Ground Installation (PL-SUB15+PL-CA12) .....	16
Flown Vertical (PL-SUB10 / PL-SUB12 / PL-SUB15) .....	17
Flown Horizontal (PL-SUB10 / PL-SUB12 / PL-SUB15) .....	17
Flown Horizontal with Frame (PL-SUB15) .....	18
Flown Horizontal with Frame (PL-SUB15+PL-CA12) .....	18
Flown PL-SUB18 to the PL-LA12-AF Array Frame .....	20
Attaching a PL-SUB18 under a PL-SUB18 .....	21
Flying a single PL-SUB18 without Array Frame .....	22

<b>Input Connection</b> .....	<b>22</b>
<b>Installing the Optional Input Cover</b> .....	<b>23</b>
To use the weather cover: .....	23
<b>System Amplification</b> .....	<b>24</b>
System Processing .....	24
Number of Loudspeakers per Amplifier Channel .....	24
Knowledge Base .....	25
Customer Support .....	25
Warranty .....	25

## EXPLANATION OF SYMBOLS

The term "**WARNING!**" indicates instructions regarding personal safety. If the instructions are not followed, the result may be bodily injury or death.

The term "**CAUTION!**" indicates instructions regarding possible damage to physical equipment. If these instructions are not followed, it may result in damage to the equipment that may not be covered under the warranty.

The term "**IMPORTANT!**" indicates instructions or information that are vital to the successful completion of the procedure.

The term "**NOTE**" is used to indicate additional useful information.



The lightning flash with arrowhead symbol in a triangle alerts the user to the presence of uninsulated dangerous voltage within the product's enclosure that may constitute a risk of electric shock to humans.



The exclamation point within a triangle alerts the user to the presence of important safety, operating, and maintenance instructions in this manual.

## IMPORTANT SAFETY INSTRUCTIONS



**WARNING!:** While it is possible for one person to lift a loudspeaker, it is important to use proper lifting techniques. Suggested reading: OSHA Technical Manual (OTM) > Back Disorders and Injuries: <https://www.osha.gov/otm/>

1. Read, follow, and keep these instructions.
2. Heed all warnings.
3. Clean only with a dry cloth.
4. Do not install near any heat sources such as radiators, heat registers, stoves, or other apparatus (including amplifiers) that produce heat.
5. Only use attachments/accessories specified by the manufacturer.
6. Refer all servicing to qualified service personnel.
7. Adhere to all applicable, local codes.
8. Consult a licensed, professional engineer when any doubt or questions arise regarding a physical equipment installation.
9. Suspension of this product should be done by qualified persons following safe rigging practices. Other limitations may apply.
10. Use only the recommended system components and suspension hardware intended for use with this product as directed by this manual.
11. Do not use Q-SYS suspension hardware for purposes outside the scope of this manual.



**WARNING!:** Read and follow the installation instructions carefully. If these products are not suspended properly, they could fall, causing personal injury or death and damage to the equipment. Refer to the user manual for rules on suspension.

## RoHS Statements

The Q-SYS PL Series loudspeakers are in compliance with European RoHS Directive.

The Q-SYS PL Series loudspeakers are in compliance with "China RoHS" directives. The following table is provided for product use in China and its territories.

部件名称 (Part Name)	Q-SYS PL Series					
	有害物质 (Hazardous Substances)					
	铅 (Pb)	汞 (Hg)	镉 (Cd)	六价铬 (Cr(vi))	多溴联苯 (PBB)	多溴二苯醚 (PBDE)
电路板组件 (PCB Assemblies)	X	○	○	○	○	○
机壳装配件 (Chassis Assemblies)	X	○	○	○	○	○

本表格依据 SJ/T 11364 的规定编制。

○: 表示该有害物质在该部件所有均质材料中的含量均在 GB/T 26572 规定的限量要求以下。

X: 表示该有害物质至少在该部件的某一均质材料中的含量超出 GB/T 26572 规定的限量要求。

(目前由于技术或经济的原因暂时无法实现替代或减量化。)

This table is prepared following the requirement of SJ/T 11364.

○: Indicates that the concentration of the substance in all homogeneous materials of the part is below the relevant threshold specified in GB/T 26572.

X: Indicates that the concentration of the substance in at least one of all homogeneous materials of the part is above the relevant threshold specified in GB/T 26572.

(Replacement and reduction of content cannot be achieved currently because of the technical or economic reason.)

## Safety Regulations and Protection Ratings

Product Configurations covered by this manual are designed and tested for compliance to the following regulations and standards:

- 2001/95/EC General Product Safety Directive
- EN 62368-1
- IEC 60529 IP54

See PL-LA manual for additional certification concerning the rigging of PL-SUB18 + PL-LA.

## Warranty

For a copy of the Q-SYS Limited Warranty, visit the Q-SYS website at [www.qsys.com](http://www.qsys.com).



**NOTE:** Read and follow these instructions carefully. If the loudspeakers are not suspended properly, they could fall, causing personal injury and damage to the equipment. Please refer to the Flown Deployment chapter of the User Manual for rules on suspension.

## General Rules for Suspension

- Consult a professional mechanical or structural engineer, licensed in the jurisdiction of the sound system installation, to review, verify, and approve all attachments to the building or structure.
- Employ the services of a certified, professional rigger for hoisting, positioning, and attaching the equipment to the supporting structure.
- Correct use of all suspension hardware and components is imperative in sound system suspension and deployment.
- Consult local codes and regulations to fully understand the requirements for suspended loads in the venue in which equipment will be suspended.
- Use only dedicated PL-SUB accessories when deploying the loudspeakers. Further details can be found below.
- Be absolutely certain of the integrity of any structural member intended to support suspended loads. Hidden structural members can have hidden structural weakness.
- Never assume anything! Owner or third-party supplied suspension attachment points may not be adequate for suspending the loads.
- Before lifting, always inspect all components (enclosures, suspension brackets, pins, frames, bolts, nuts, slings, shackles, etc.) for cracks, wear, deformation, corrosion, missing, loose, or damaged parts that could reduce the strength of the assembly. Discard any worn, defective, or suspect parts and replace them with new, appropriately load-rated parts.

## Shock Loading

When a load is moved or stopped, its static weight is magnified. Sudden movements can magnify the static weight several times. This is called "shock loading."

The effects of shock loading can be instantaneous, or they can remain undetected. Proper preparation for shock loading requires careful planning and knowledge of equipment, suspension, and lifting practices. Shock loading is most often the result of lifting and installation, but natural forces (winds, earthquakes, etc.) can create shock loads several times the static load.

Shock loading poses a danger to equipment and workers. Because of this, structures and suspension equipment must be capable of supporting several times the weight of the suspended equipment.

# Introduction

The Q-SYS PL-SUB family is composed of passive installation subwoofers that feature a weatherized wooden enclosure in a compact form factor suited for a broad range of applications, from entertainment and small sporting venues to corporate auditoriums or higher-ed lecture halls. Four models (10-inch, 12-inch, 15-inch, and 18-inch) provide an abundance of options to ensure the right solution anywhere in the venue that requires higher performance audio.

## Key Features and Technologies

- Four models available for optimal flexibility
- Weatherized (IP54) wooden enclosure for indoor and protected outdoor environments
- Pair with Q-SYS CX-Q network amplifiers for advanced system optimization through custom voicing and filter sets

## Outdoor Deployment

This equipment has been designed to withstand weather conditions encountered in protected outdoor environments. Ensure that the loudspeakers are positioned under cover to protect them. Direct deployment in environments close to the seaside or with a high degree of corrosion is not recommended.





While the grille is protected by a mesh that avoid ingress of water into the port, it is recommended to angle the loudspeaker with a down tilt of 5° to allow eventual creeping water to get out of the loudspeaker by gravity.

These loudspeakers feature the following:



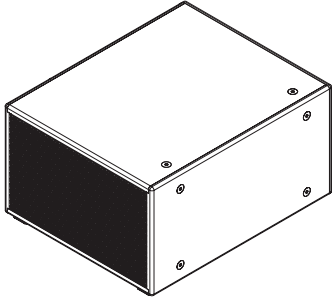
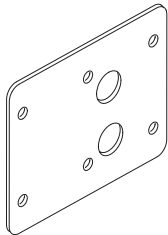

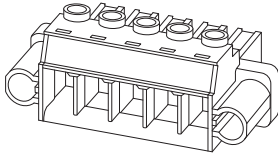
- IP54
- External plywood
- Stainless screws
- Treated grille vs. UV and corrosion
- Hydrophobic stainless steel mesh behind grille
- Polyurea paint
- Input cup (IP65) sealing with gland

# What's in the Box

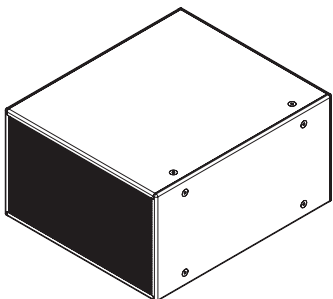
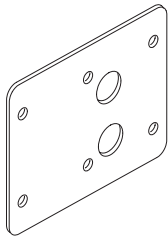

## PL-SUB10 Subwoofer

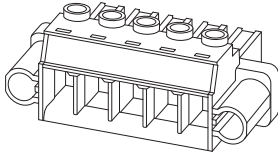
 <p>(1) PL-SUB10 SUBWOOFER</p>	 <p>(1) SG-000740-01 INPUT COVER FOR IP65</p> <p>(6) SC-000814-01 SCREWS FOR INPUT COVER</p> <p>(1) HOLE COVER LB-004261-20</p>
 <p>(1) TD-001688-00 SAFETY &amp; REGULATORY STATEMENTS</p>	 <p>(1) CO-000981-01 CONNECTOR 4 POLES</p>  <p>(1) WARRANTY STATEMENT</p>

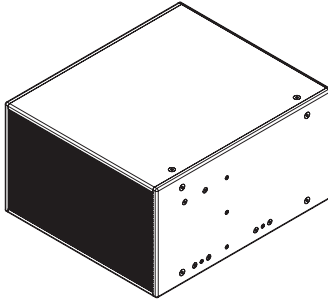
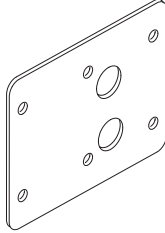
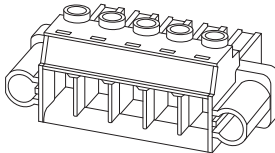

## PL-SUB12 Subwoofer

 <p>(1) PL-SUB12 SUBWOOFER</p>	 <p>(1) SG-000740-01 INPUT COVER FOR IP65</p> <p>(6) SC-000814-01 SCREWS FOR INPUT COVER</p> <p>(1) HOLE COVER LB-004261-20</p>
 <p>(1) TD-001688-00 SAFETY &amp; REGULATORY STATEMENTS</p>	 <p>(1) CO-000981-01 CONNECTOR 4 POLES</p>  <p>(1) WARRANTY STATEMENT</p>

## PL-SUB15 Subwoofer

	<p>(1) PL-SUB15 SUBWOOFER</p>		<p>(1) SG-000740-01 INPUT COVER FOR IP65</p> <p>(6) SC-000814-01 SCREWS FOR INPUT COVER</p> <p>(1) HOLE COVER LB-004261-20</p>
			<p>(1) CO-000981-01 CONNECTOR 4 POLES</p>
	<p>(1) TD-001688-00 SAFETY &amp; REGULATORY STATEMENTS</p>		<p>(1) WARRANTY STATEMENT</p>

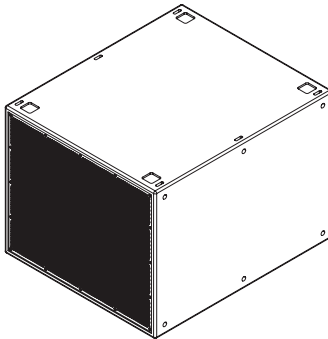
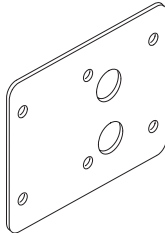
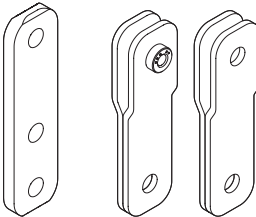
## PL-SUB18 Subwoofer

	<p>(1) PL-SUB18 SUBWOOFER</p>		<p>(1) SG-000740-01 INPUT COVER FOR IP65</p> <p>(6) SC-000814-01 SCREWS FOR INPUT COVER</p> <p>(1) HOLE COVER LB-004261-20</p>
	<p>(4) CH-008428-01 STRAIGHT LINK</p> <p>(2) CH-008430-01 Y-LINK</p>		<p>(1) TD-001688-00 SAFETY &amp; REGULATORY STATEMENTS</p>
			<p>(1) WARRANTY STATEMENT</p>

## Accessories (Available Separately)

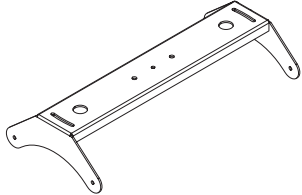
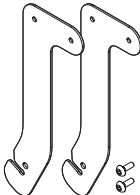
	<p>(1) PL-SUB15-AF SUSPENSION FRAME</p> <p>(4) PL-003593-01 SPACER</p> <p>(2) NW-000360-01 EYE NUT, M8, ID 20MM, OD 36MM + SC-000833-01 BOLT + WASHERS</p> <p>(4) SC-000834-01 SCREW (M8x25)</p>		<p>(2) PL-CA12-LK, SUB LINK</p> <p>(2) PL-003591-01 SPACER</p> <p>(2) PL-003592-01 SPACER YOKE</p> <p>(4) SC-000834-01 SCREW, M8 25MM</p> <p>(2) SC-000826-02 SHOULDER SCREW</p>
-------------------------------------------------------------------------------------	------------------------------------------------------------------------------------------------------------------------------------------------------------------------------------------------------------------	-------------------------------------------------------------------------------------	----------------------------------------------------------------------------------------------------------------------------------------------------------------------------------

# PL-SUB10 / PL-SUB12 Features

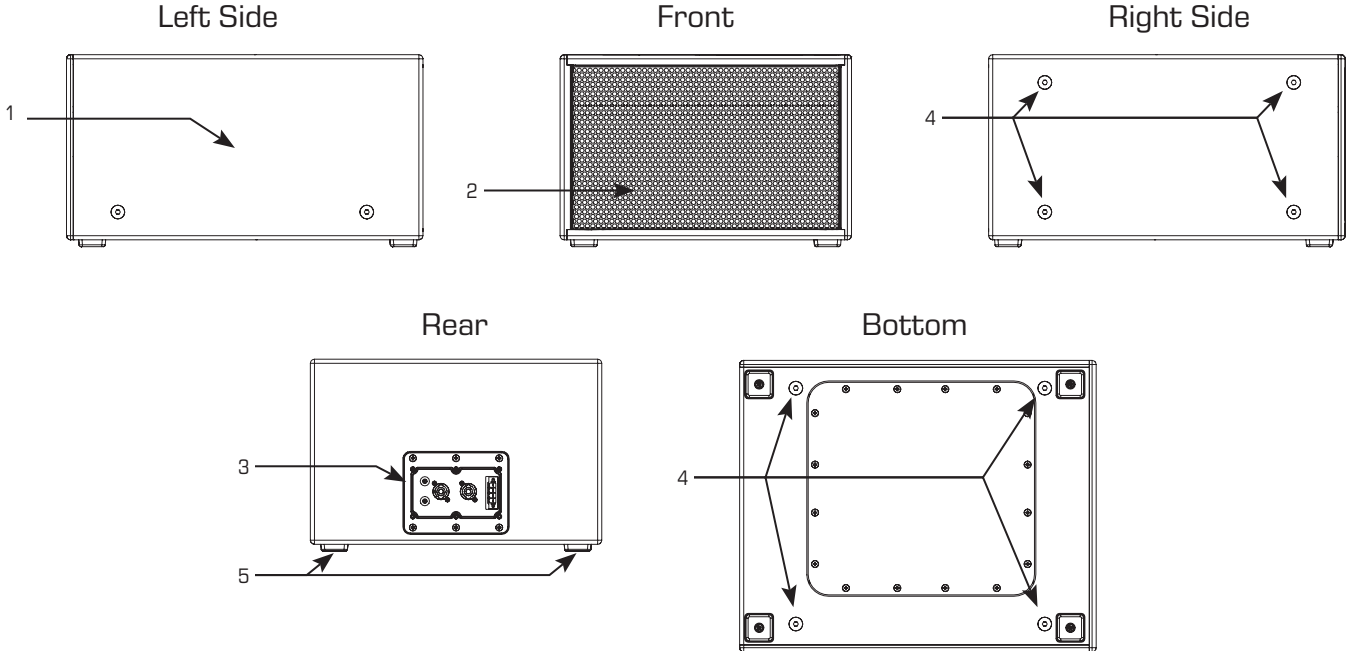

— Figure 1 —

1. Wood enclosure
2. Weatherized steel grille
3. Rear panel input cup
4. M10 suspension points
5. Slip-resistant feet

# PL-SUB15 Features

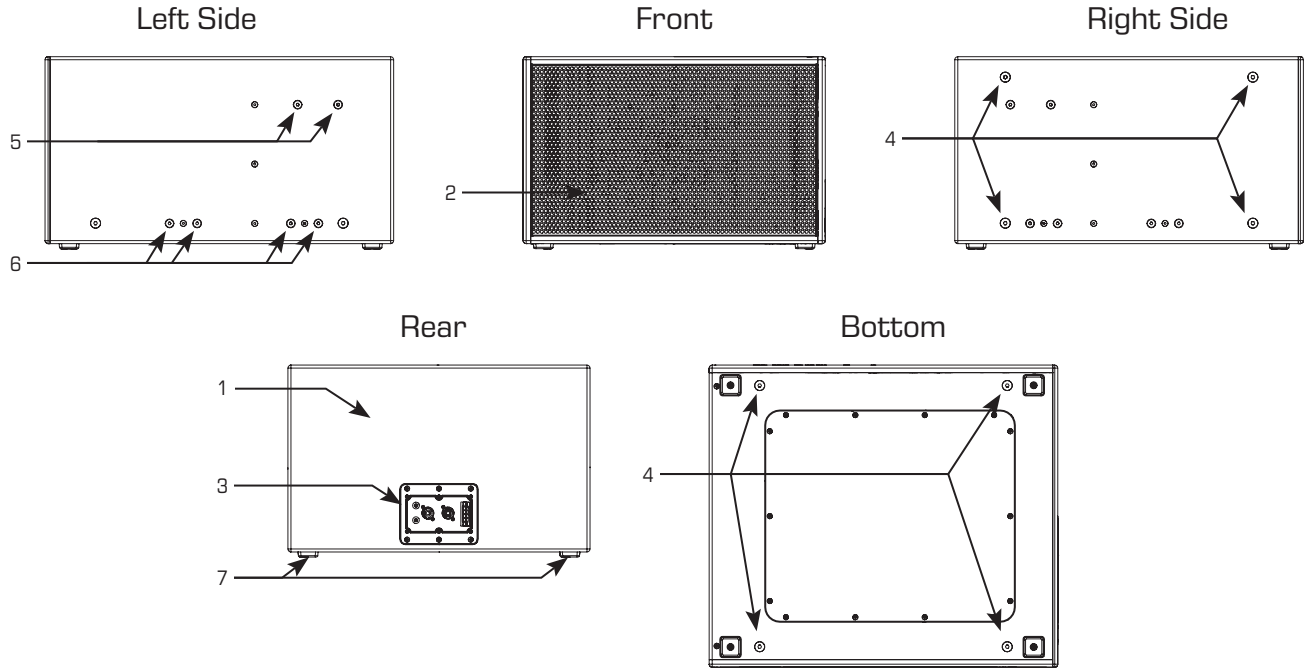

— Figure 2 —

1. Wood enclosure
2. Weatherized steel grille
3. Rear panel input cup
4. M10 suspension points
5. M8 suspension points for link to PL-CA12
6. M8 suspension points for Suspension Frame
7. Slip-resistant feet

## PL-SUB18 Features

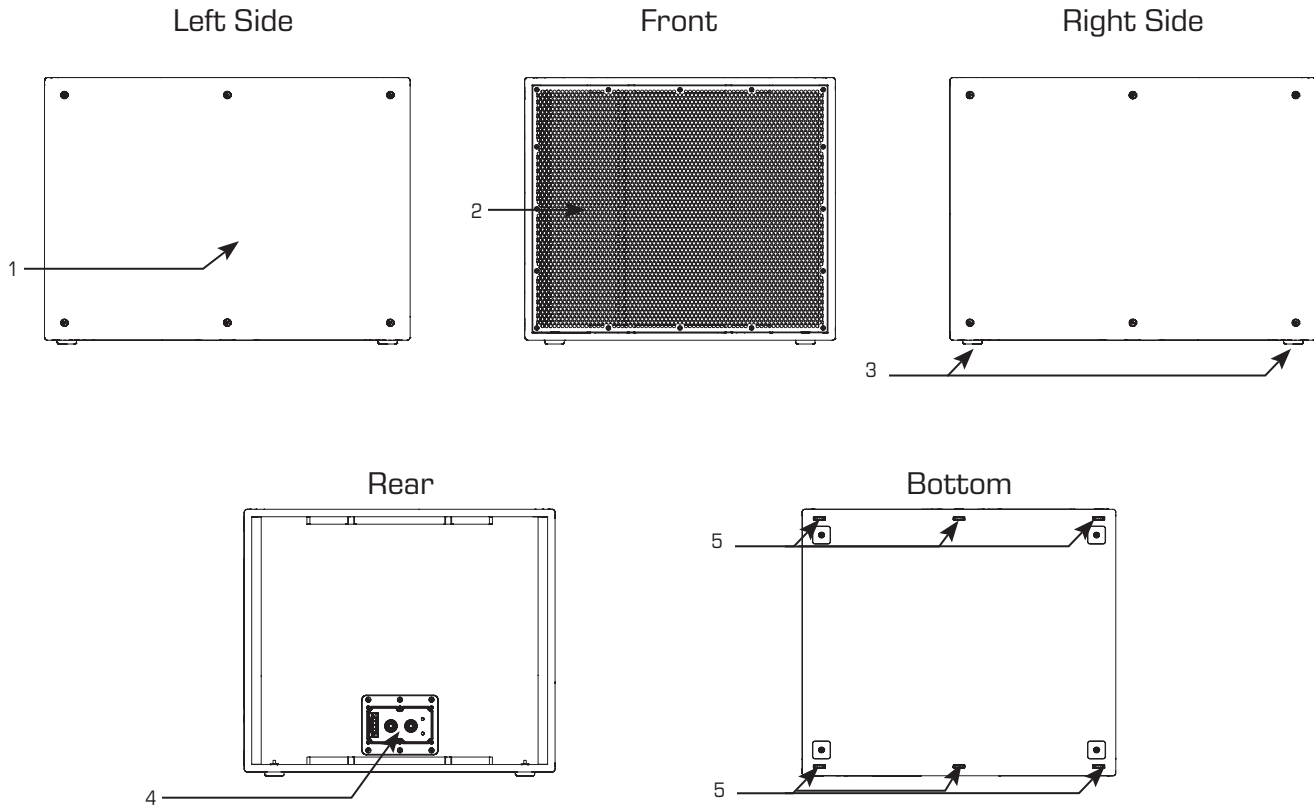

— Figure 3 —

1. Exterior plywood enclosure
2. Weatherized steel grille
3. Slip-resistant feet
4. Rear panel input cup and Working Load Limit (WLL) indications
5. Integrated Rigging System

## PL-LA12-AF Array Frame

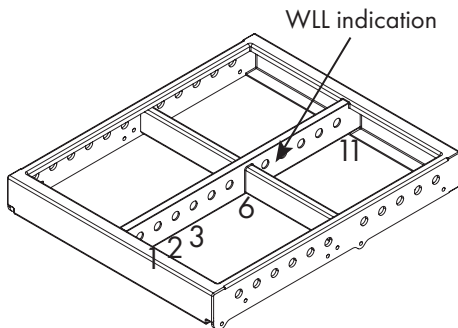

**NOTE:** For further information on PL-SUB18 deployment with PL-LA, see the PL-LA user manual.

# Mounting Options and Deployment

## PL-SUB15 / PL-SUB18 Cardioid Configuration

Two or more PL-SUB15 or PL-SUB18 subwoofers can be arranged and configured to produce a cardioid radiation pattern. The processing necessary for cardioid operation is already programmed into each PL-SUB Q-SYS Designer Software Inventory block. On each subwoofer facing forward (toward the audience), select the OMNI property. On each subwoofer facing away from the audience, select CARDIO on the property menu. Put the same audio signal into both subwoofers and set the same gain on each one. Refer to the Q-SYS online documentation.

3 Cardioid configurations can be deployed:

- Back-to-back
- Stacked (flown in the array or ground-stacked)
- Side by Side

### Back-to-back

Placing the subwoofers back-to-back offers the best cardioid performance, with 15 dB of sound attenuation to the rear. Space between subwoofers should be around 10 cm.

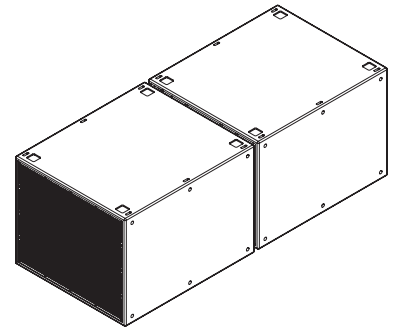

### Stacked

Place the rear-facing subwoofer on the bottom when ground-stacked, and on the top when flown. (See page 15 for assembling the PL-SUB18 together)

**NOTE:** Only the PL-SUB18 can be flown in Cardioid Configuration.

**NOTE:** The PL-SUB15 does not have feet pockets. Secure both subwoofers together when stacked.

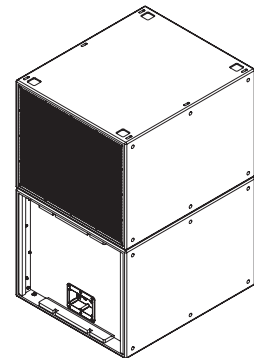

### Side by Side

Placing the subwoofers side-by-side may save space but creates a less precise cardioid pattern. Use the same Q-SYS settings as for Cardio-Stacked.

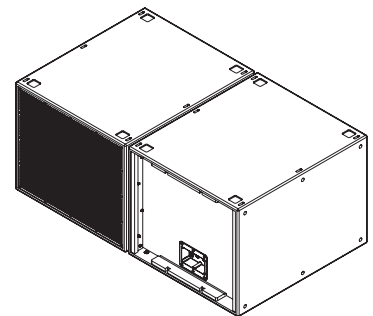

Figure 4

## Three-Box Cardioid Systems

A three-box array, with two forward-facing subwoofers and one rear-facing subwoofer, gives additional acoustic output to the front.

Figure 5 (1) shows a stacked three-box array. Use the bottom subwoofer as the rear-facing one when ground stacking, and at the top when flown.

Figure 5 (2) shows a back-to-back three-box array.

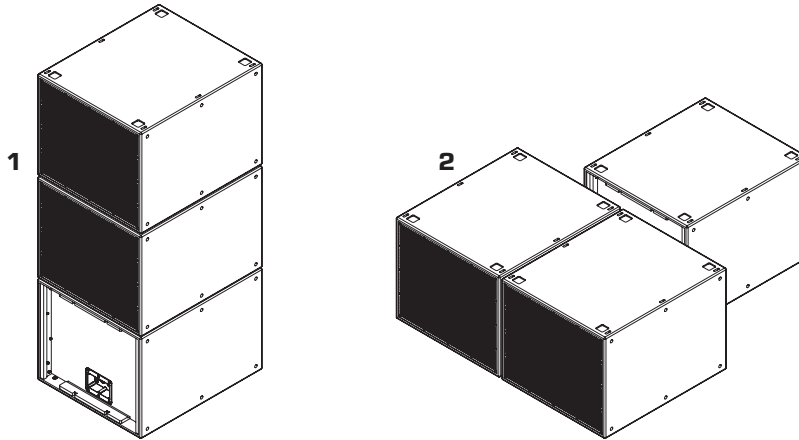

— Figure 5 —

## Cable Management and Fake Grille (PL-SUB18 Only)

For applications where cosmetic appeal is important, you can install another grille on the back of the rear facing PL-SUB18. In that case, the Rear Panel Connection won't be accessible anymore and it will be necessary to route the Input cable thru the port to the input cup connector as shown below. A small opening will have to be made into the front grille to allow the cable to get into the PL-SUB18 subwoofer. It is recommended to attach the cable on the inside wall of the port, and then securing it to one of the columns holding the PCB.

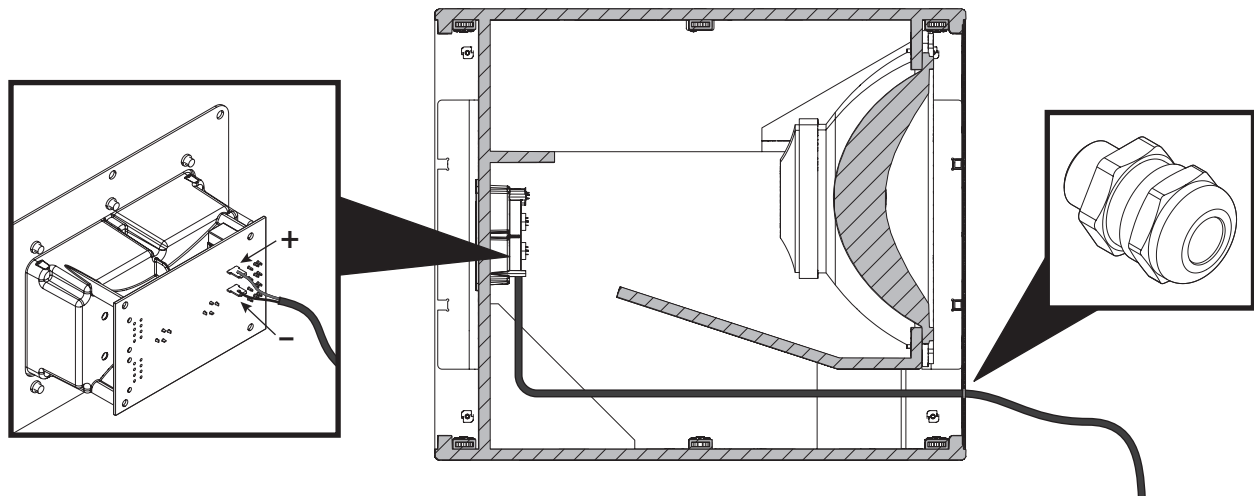

— Figure 6 —

# Stacking Two PL-SUB18

- 1. Attach two Straight Links to the middle slots of the PL-SUB18 (do not torque yet).
- 2. Place the second PL-SUB18 on top of the first PL-SUB18.
- 3. Torque to 11.3 N·m (100 lbf·in) with the bolts provided.

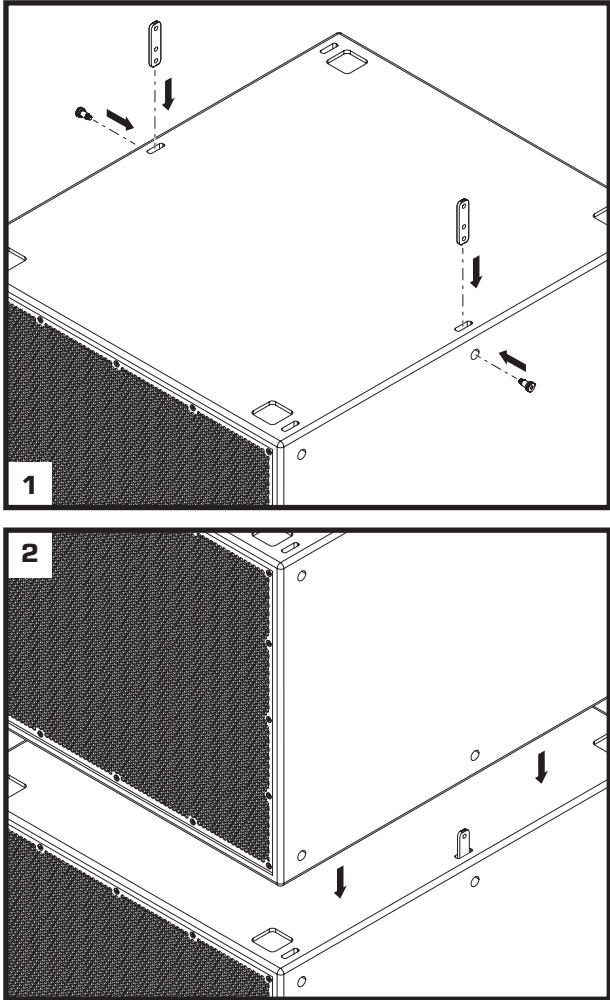
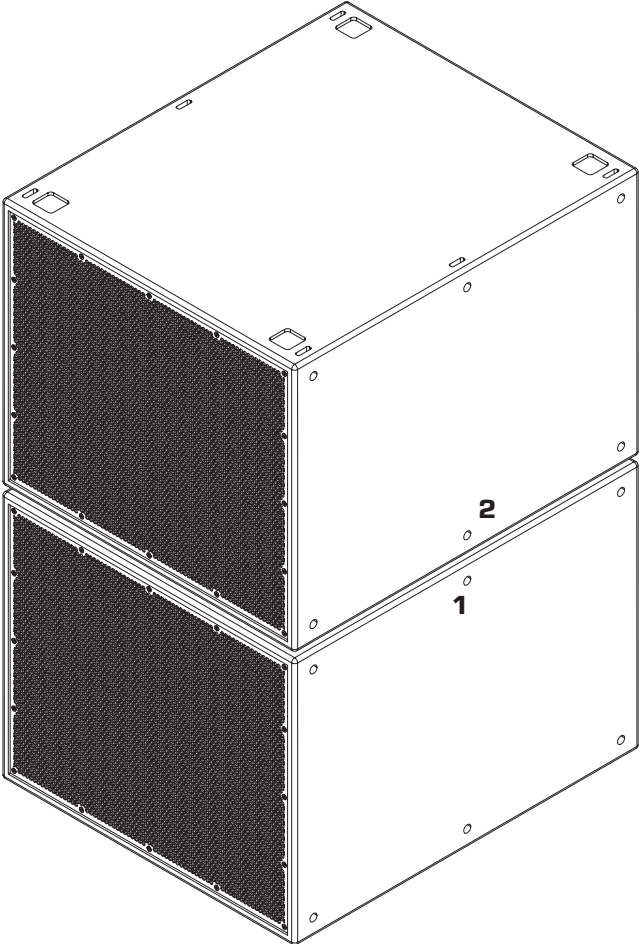

— Figure 7 —

## Ground Installation (PL-SUB15+PL-CA12)

1. Insert an M8 screw into the yoke hole on the PL-CA12 loudspeaker.
2. Install the PL-CA12-LK link on the PL-SUB15 using the M8x25 screws provided.
3. Hang the loudspeaker on the bracket by inserting the M8 screws into the bracket slots.
4. Angle the loudspeaker. When using the slot, the loudspeaker can be angled from  $-5^{\circ}$  to  $+40^{\circ}$ ; when using the hole, the loudspeaker can be angled at  $+26^{\circ}$ .

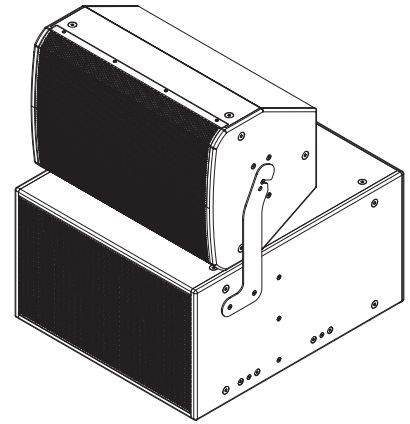

### Using Slot

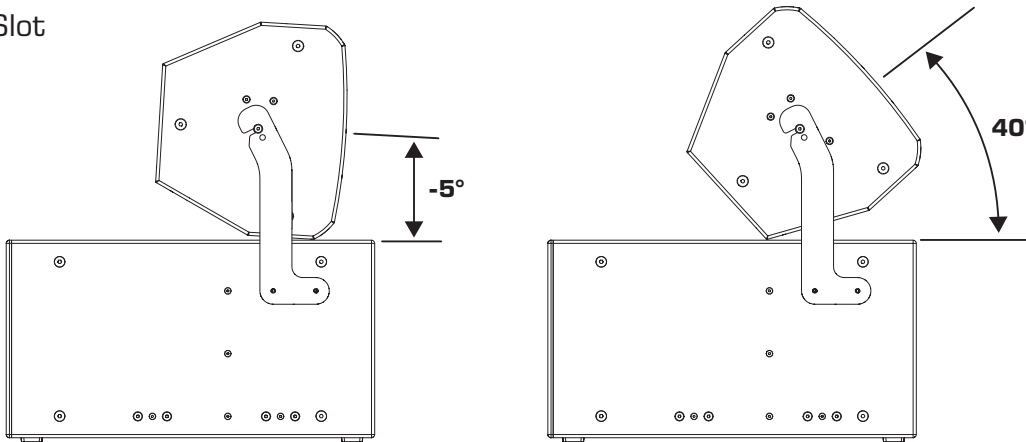

### Using Hole

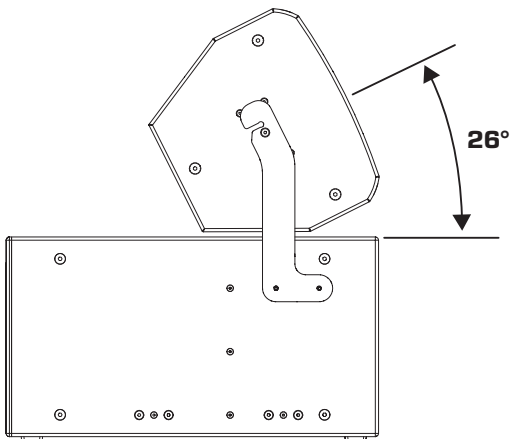

— Figure 8 —

## Flown Vertical (PL-SUB10 / PL-SUB12 / PL-SUB15)

1. Insert eye bolts in the M10 suspension points.
2. Hang straight or attach bridles to the sides of the subwoofer so that the top angle is greater than  $45^\circ$ .

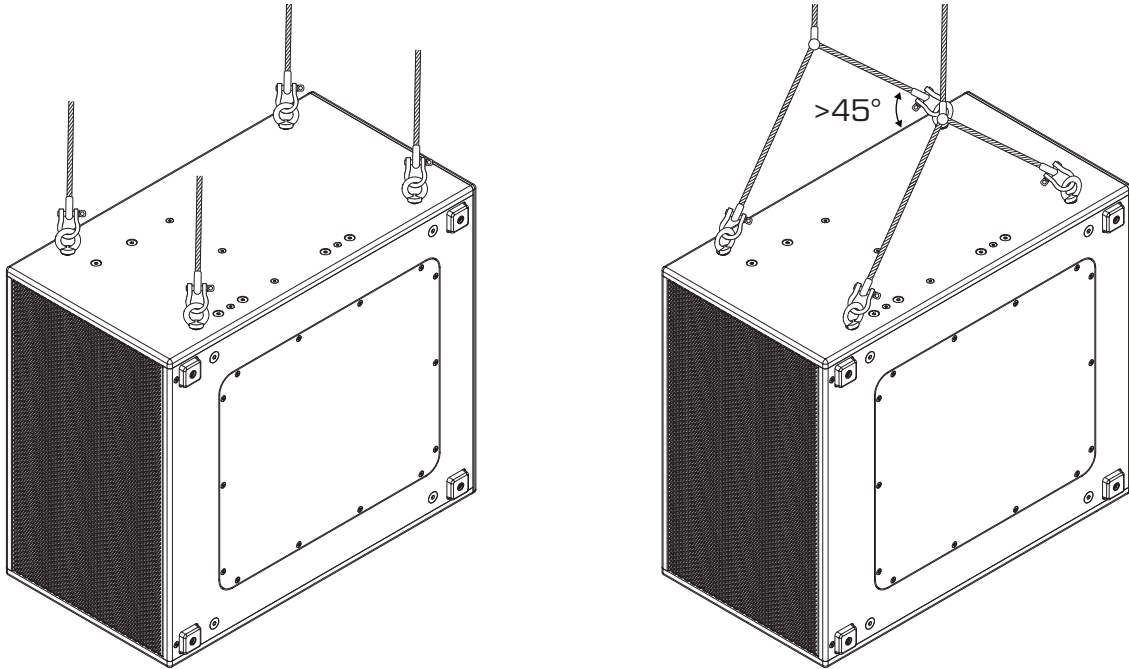

— Figure 9 —

## Flown Horizontal (PL-SUB10 / PL-SUB12 / PL-SUB15)

1. Insert eye bolts in the M10 suspension points on the bottom of the SUB.
2. Hang straight or attach bridles to the sides of the subwoofer so that the top angle is greater than  $45^\circ$ .

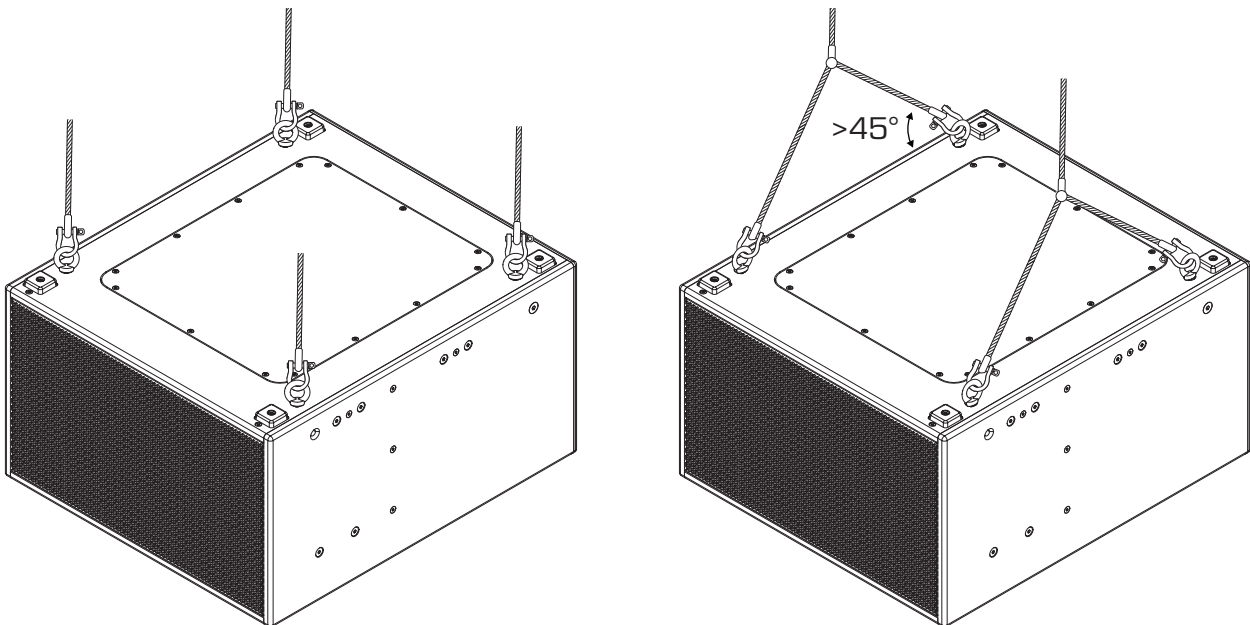

— Figure 10 —

### Flown Horizontal with Frame (PL-SUB15)

1. Install the M8 eye nuts with bolts provided on the frame.
2. Install the suspension frame on the enclosure (A) then secure it using the M8x25 screws provided.

**NOTE:** The suspension frame does not use the same M8 holes when used alone or when supporting a PL-CA12.

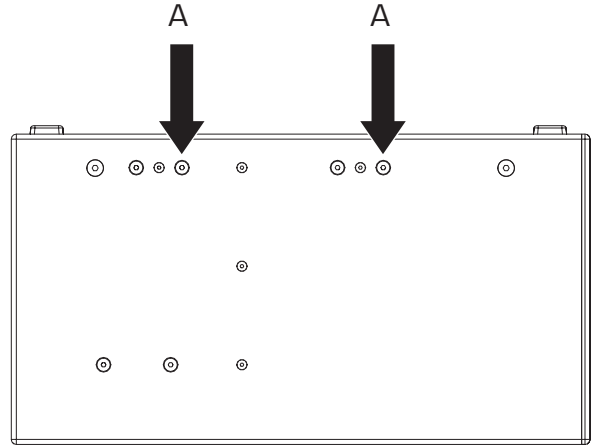
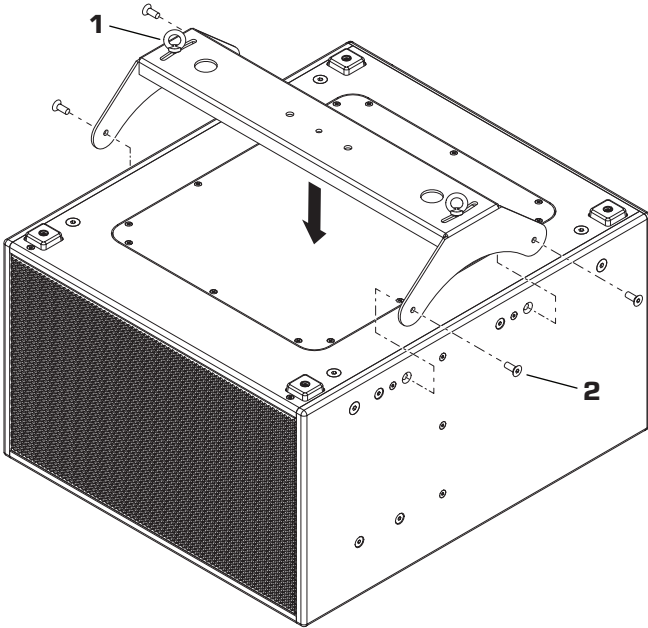

— Figure 11 —

### Flown Horizontal with Frame (PL-SUB15+PL-CA12)

1. Install the M8 eye nuts with bolts provided on the frame.
2. Install the suspension frame on the enclosure (B) and then secure it using the M8x25 screws provided.

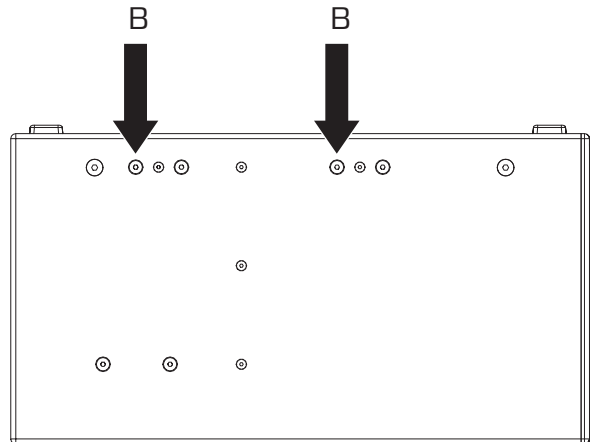
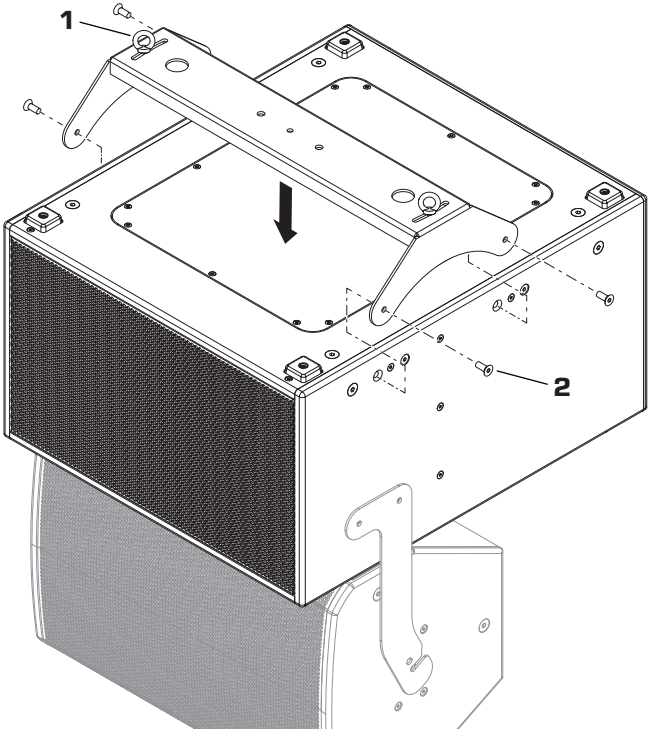

— Figure 12 —

3. Install the PL-CA12-LK link on the PL-SUB15 using the M8x25 screws provided.
4. Insert an M8 screw into the yoke hole on the PL-CA12 loudspeaker.
5. Hang the loudspeaker on the bracket by inserting the M8 screws into the bracket slots.
6. Angle the loudspeaker. When using the slot, the loudspeaker can be angled from  $-5^{\circ}$  to  $+40^{\circ}$ ; when using the hole, the loudspeaker can be angled at  $+26^{\circ}$ .

**NOTE:** The suspension frame does not use the same M8 holes when used alone or when supporting a PL-CA12.

**NOTE:** Metallic continuity is ensured from the suspension frame to the PL-CA12 loudspeaker thanks to a plate located inside the PL-SUB15 subwoofer.

**WARNING!:** DO NOT USE M10 RIGGING POINTS WHEN DEPLOYING A PL-CA12 UNDER A PL-SUB15. The metallic continuity does not exist in this case.

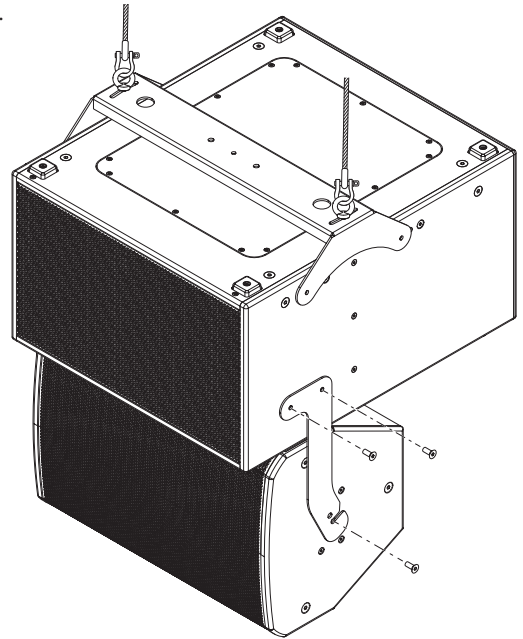
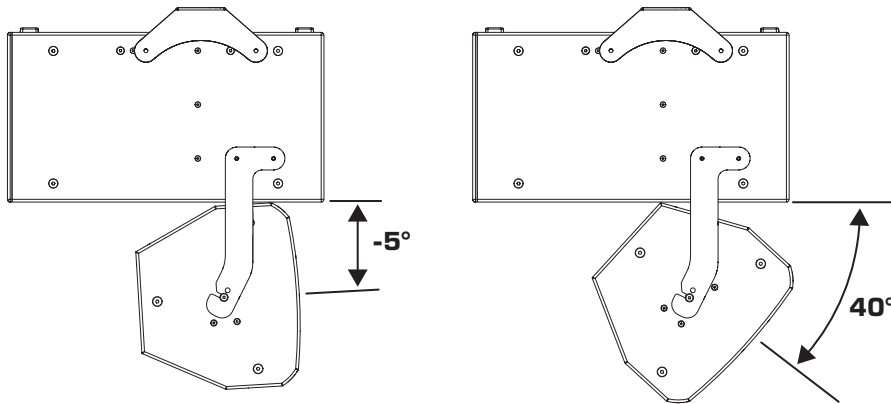
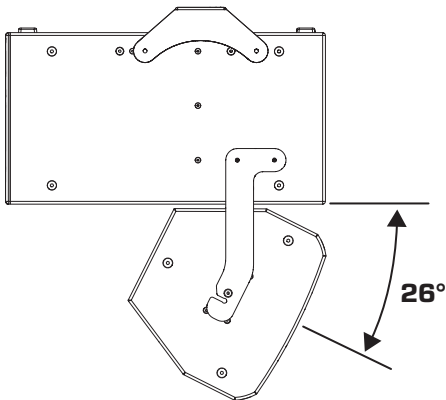

Figure 13

#### Using Slot



#### Using Hole



— Figure 14 —

# Flown PL-SUB18 to the PL-LA12-AF Array Frame

- 1. Attach the inter-connect Y-Links on the array frame — two links at the front and two links in the middle.

**NOTE:** The nut side of the Y-Link will always be placed to the inside of the array.

- 2. Insert the links into the PL-SUB18.
- 3. Tighten the bolts to secure. Torque to 11.3 N·m (100 lbf·in).

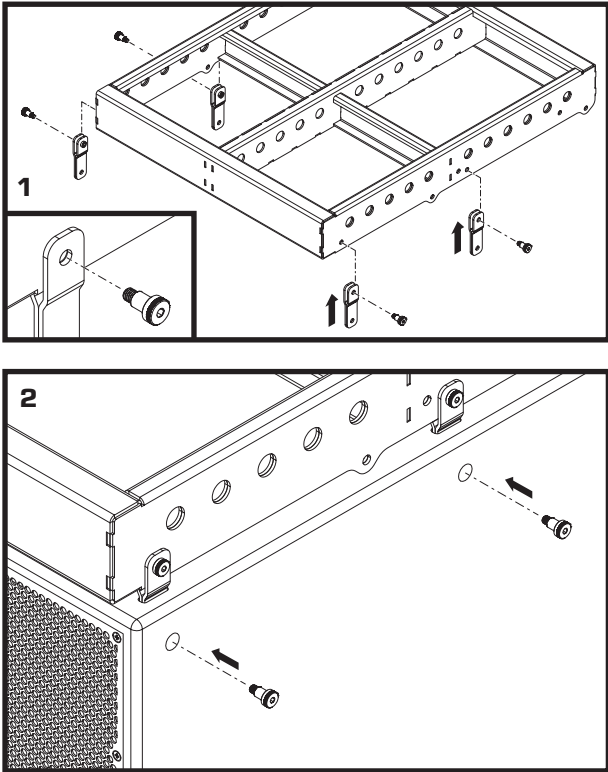
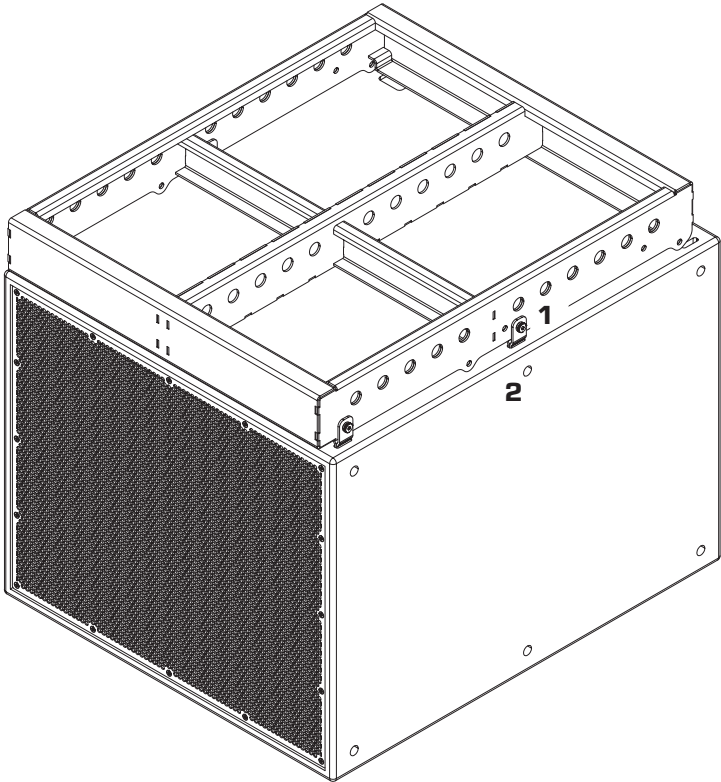

— Figure 15 —

## Attaching a PL-SUB18 under a PL-SUB18

1. Insert the inter-connect Straight Links into the PL-SUB18, always two at the front and two in the middle. Ensure that the Straight Links are always aligned with frame attachment.
2. Attach the link from the top of the bottom PL-SUB18 into the base of the top PL-SUB18.
3. Torque the four bolts to 11.3 N·m (100 lbf·in) to ensure that the bottom PL-SUB18 is correctly fastened to the top PL-SUB18.

**NOTE:** Metallic continuity is ensured from the array frame to the PL-LA 12 loudspeaker thanks to a strut located inside the PL-SUB18 subwoofer. (See dotted line on Figure 16)

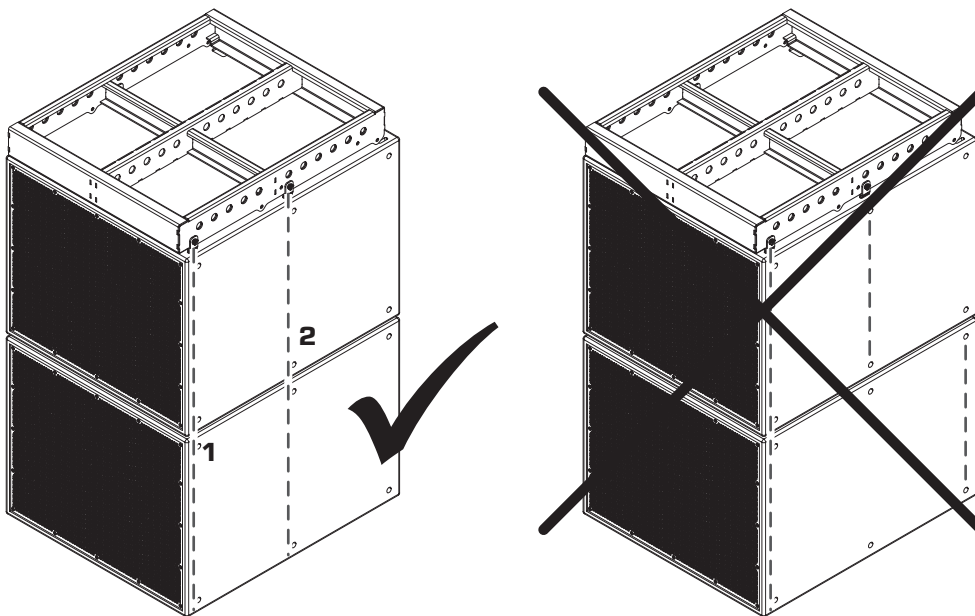
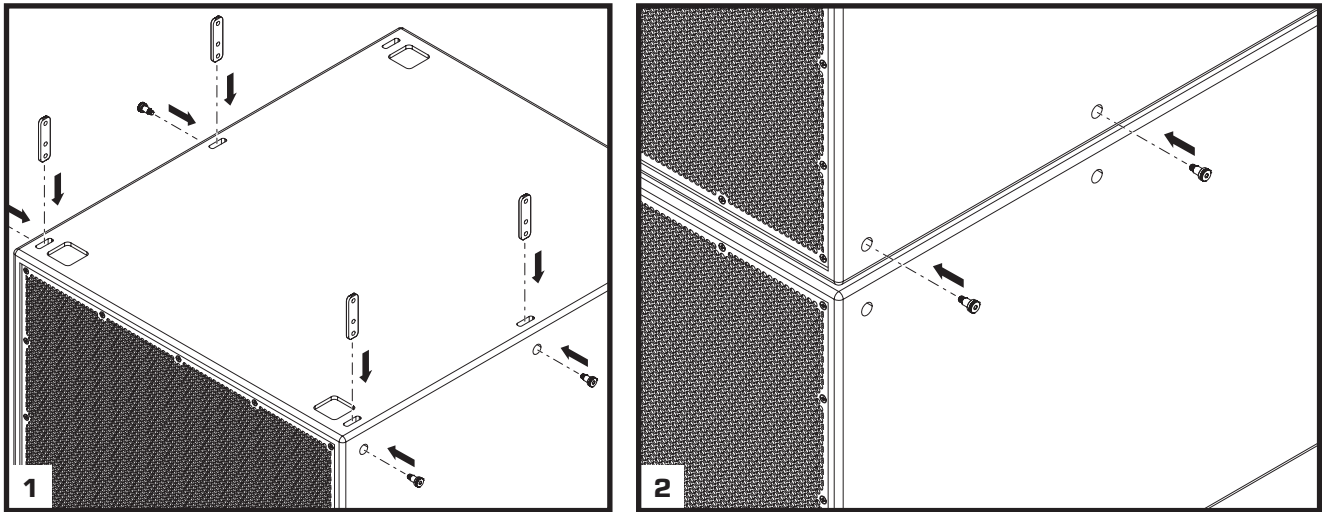

— Figure 16 —

## Flying a single PL-SUB18 without Array Frame

1. Attach four 1/4 in. shackles with an 8 mm pin shaft to the Straight Links in a straight position.
2. Attach bridles to the sides of the subwoofer so that the top angle is greater than 45°.
3. Do not attach bridles to the ends of the subwoofer.

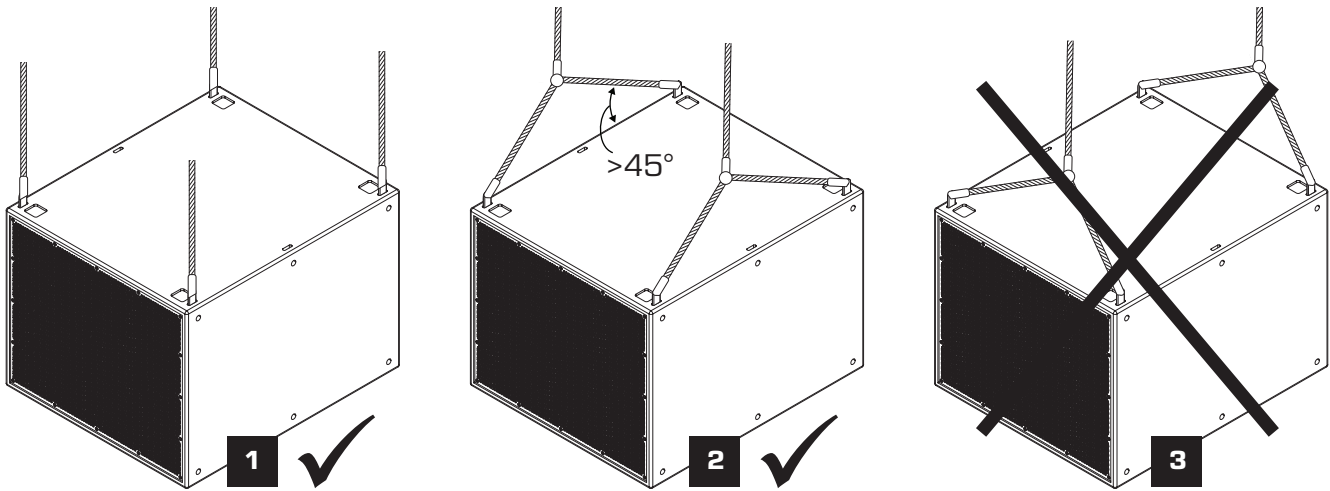

— Figure 17 —

## Input Connection

Product	Connector	Specifications
<b>PL-SUB10</b> <b>PL-SUB12</b> <b>PL-SUB15</b>	<ul style="list-style-type: none"> <li>• 1 EUROBLOCK Connector</li> </ul>	<ul style="list-style-type: none"> <li>• Current Rating 32 Arms</li> <li>• Solid Wire 8-24 AWG (up to 10 mm<sup>2</sup>)</li> <li>• 4 poles Connector 1+/1- SUB, 2-/2+ Not Connected</li> <li>• Fasten on male part with M3.5 screws</li> </ul>
<b>PL-SUB18</b>	<ul style="list-style-type: none"> <li>• 2 x SPEAKON NL4 (cable connector not provided)</li> </ul>	<ul style="list-style-type: none"> <li>• Locking</li> <li>• Up to 30 Arms</li> <li>• Up to 9-16 AWG gauge (up to 6 mm<sup>2</sup>)</li> <li>• Connectors are wired in parallel, allowing daisy chain THRU</li> </ul>
	<ul style="list-style-type: none"> <li>• Both connectors are recessed.</li> <li>• The plate allows 2 gland connectors (not provided) to pass the signal IN and OUT.</li> <li>• IP65 sealing is only available when using the EUROBLOCK connector.</li> </ul>	

## Installing the Optional Input Cover

Due to the variety of cable diameters, the "cable gland" (suitable for a 22.5 mm diameter hole) must be sourced independently.

The subwoofer comes with a weather cover for the input cup to protect the input connections and switches from precipitation and other weather hazards. Use the weather cover for all outdoor installations or any applications where the loudspeaker may be exposed to moisture. To ensure a good seal in the cable gland, use outdoor-rated cable with a round jacket up to 0.37 in or 9.4 mm in diameter.

### To use the weather cover:

1. Loosen the nut on the cable gland.
2. Pass the cable all the way through the nut and the rest of the gland.
3. Attach the input connector to the wires (see Input Connector, below).
4. Once the subwoofer enclosure is installed, plug the input connector into the loudspeaker's input cup. Secure the connector to the loudspeaker using the two captive retaining screws, one on each end.
5. Place the cover onto the subwoofer's input cup and attach it using the four screws, lock washers, and flat washers provided.
6. Dress the cable so there is no undue strain on it. Tighten the gland nut until the grommet inside the gland has made a tight seal onto the cable jacket.

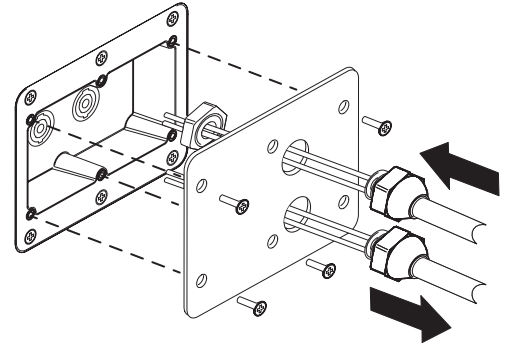

The optional input cover only accommodates the EUROBLOCK connector, not the SPEAKON NL4.

Use the hole cover LB-004261-20 for sealing the extra hole when needing only single termination.

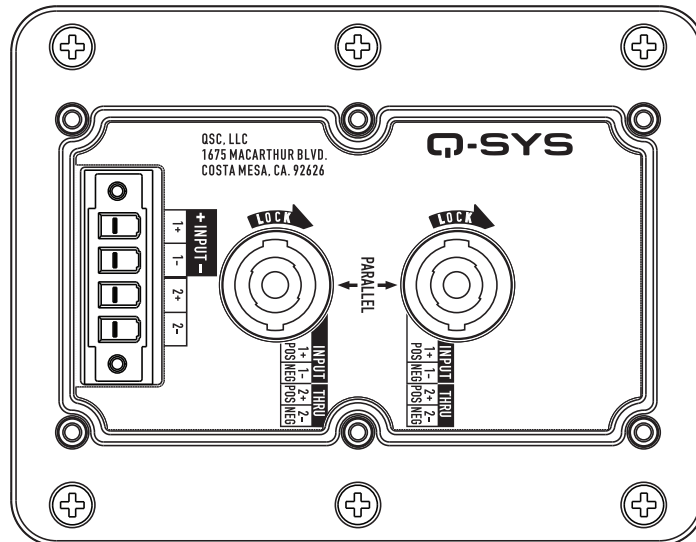

## System Amplification

The PL Series is meant to be used with CXQ amplifiers (or future generations). The exact model will depend on your application, the number of loudspeakers per channel, and the type of loudspeaker.

## System Processing

Q-SYS PL Series are designed to be used with a Q-SYS Core processor only and CXQ amplifier. Refer to the documentation for Q-SYS Designer Software ([help.qsys.com](http://help.qsys.com)) for a description of the settings.

## Number of Loudspeakers per Amplifier Channel

Loudspeaker	CXQ 2K4	CXQ 4K4	CXQ 8K4
PL-SUB10	1 BTL/Bridged	1	2
PL-SUB12	1 BTL/Bridged	1	2
PL-SUB15	-	1 BTL/Bridged	1
PL-SUB18	-	1 BTL/Bridged	1
Gain (1.2 V Setting)	33 dB	35 dB	38 dB



## Knowledge Base

Find answers to common questions, troubleshooting information, tips, and application notes. Link to support policies and resources, including Q-SYS Help, software and firmware, product documents, and training videos. Create support cases.  
[support.qsys.com](https://support.qsys.com)

## Customer Support

Refer to the Contact Us page on the Q-SYS website for Technical Support and Customer Care, including their phone numbers and hours of operation.  
[qsys.com/contact-us/](https://qsys.com/contact-us/)

## Warranty

For a copy of the QSC Limited Warranty, go to:  
[qsys.com/support/warranty-statement/](https://qsys.com/support/warranty-statement/)