

**NOTE:**

If mounting to brick, block or concrete wall, drill 5/8" diameter holes 2" deep and insert lag shields.  
If mounting to wood wall or wood stud, drill 9/32" diameter holes 1-1/2" deep.

**INSTALLATION INSTRUCTIONS**

1. Remove ground cable and then enclosure door.
2. Install gasket provided on to AC unit.
3. Insert power cord and wires through cutout in enclosure.
4. Place AC unit to enclosure by resting EZ mount tabs on cutout edge. This will hold AC unit in place while bolts are inserted.
5. Insert the four (4) 1/4-20 x 3/4" bolts with washers through enclosure into AC unit. Make sure all four (4) bolts have engaged with AC unit before tightening.
6. Tighten the four bolts evenly.
7. Attach door.
8. Attach ground cable to door.

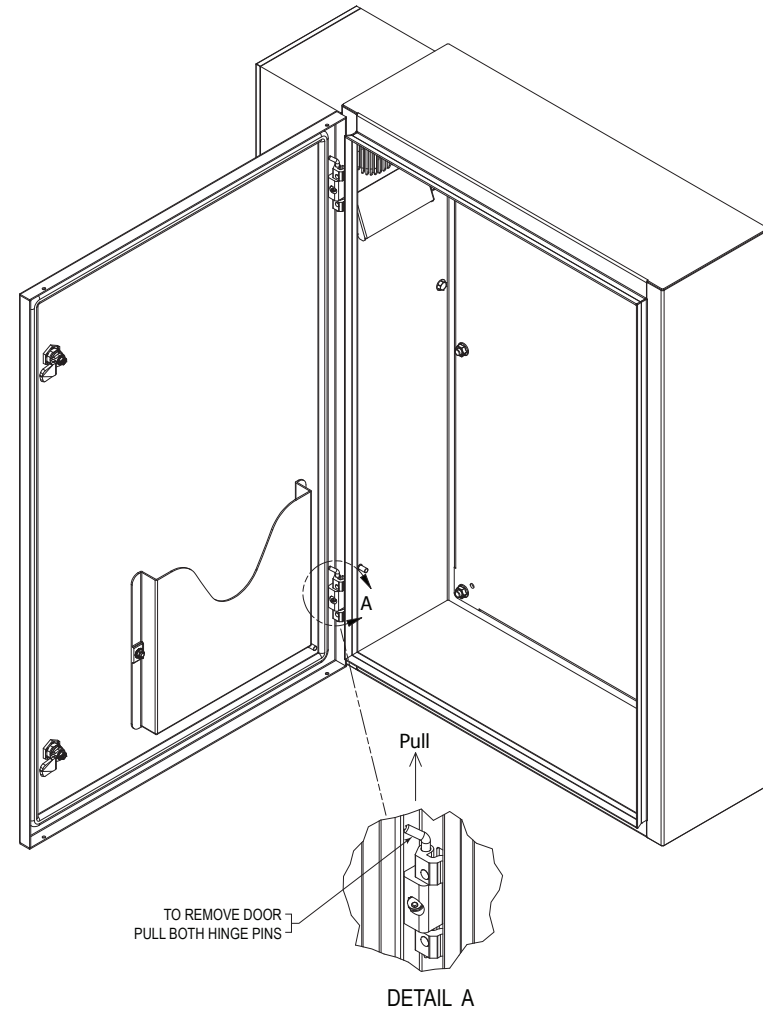

USA

Three year warranty or a one year limited warranty (from date of purchase) on most products.  
See website for details. Electronic warranty form at [www.sti-usa.com/wc14](http://www.sti-usa.com/wc14).

**EM362408A METAL PROTECTIVE CABINET WITH AC & HEAT**

All specifications and information shown were current as of publication and are subject to change without notice. Visit our website for the latest version.

EM362408A APR2025



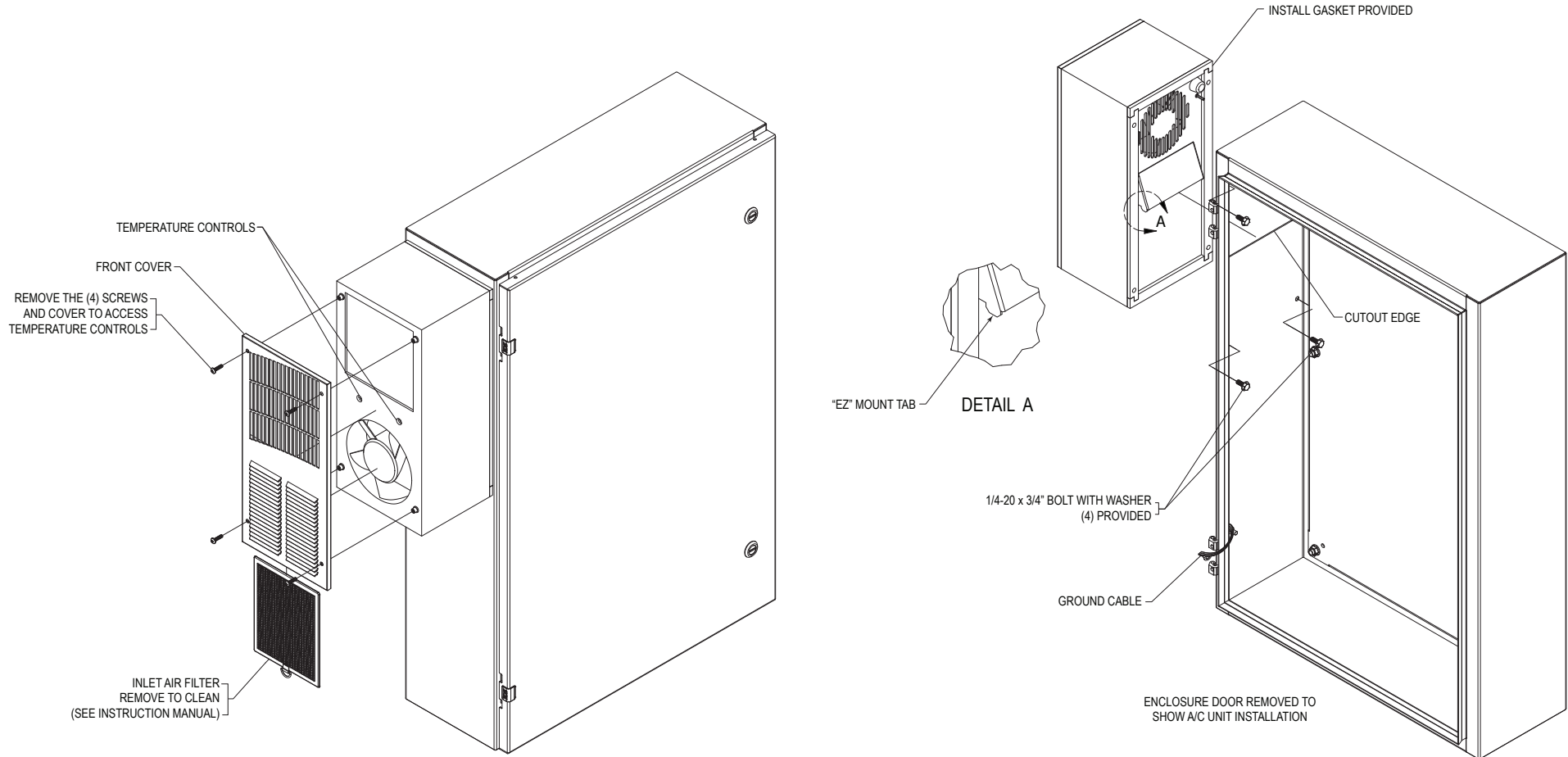

Three year warranty or a one year limited warranty (from date of purchase) on most products.  
See website for details. Electronic warranty form at [www.sti-usa.com/wc14](http://www.sti-usa.com/wc14).

**EM362408A METAL PROTECTIVE CABINET WITH AC & HEAT**

All specifications and information shown were current as of publication and are subject to change without notice. Visit our website for the latest version.

EM362408A APR2025

