

REVISION HISTORY			
DATE	REV.	DESCRIPTION	BY
2023-10-25	A	First release	JimLIU

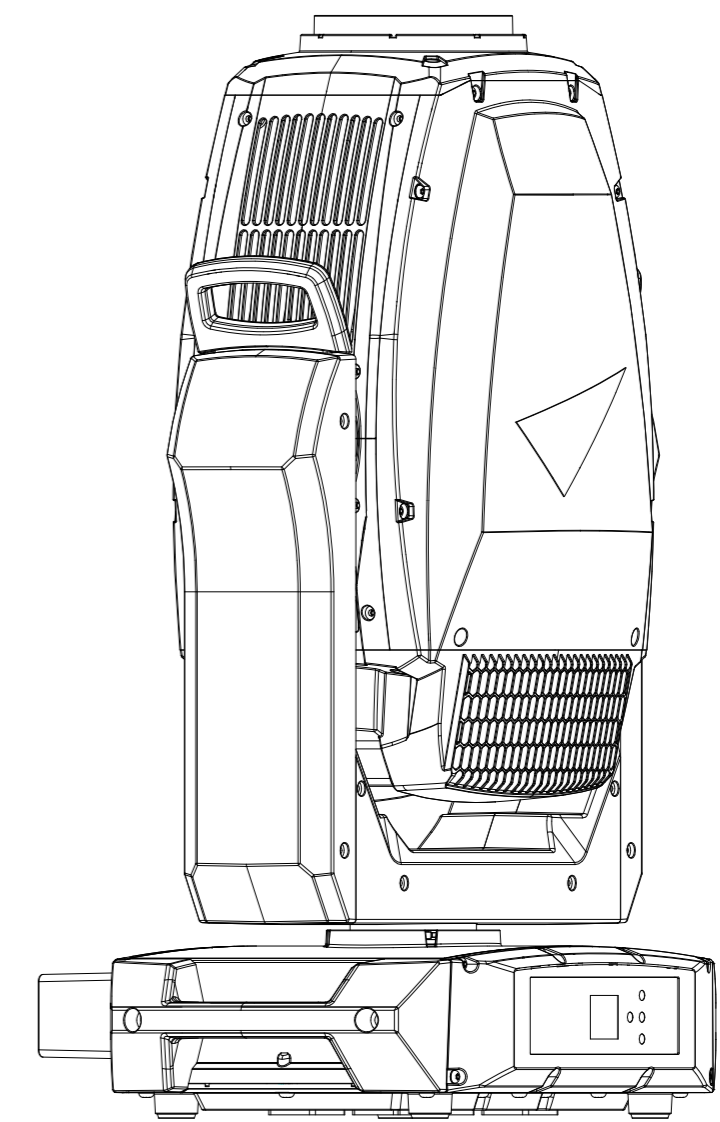
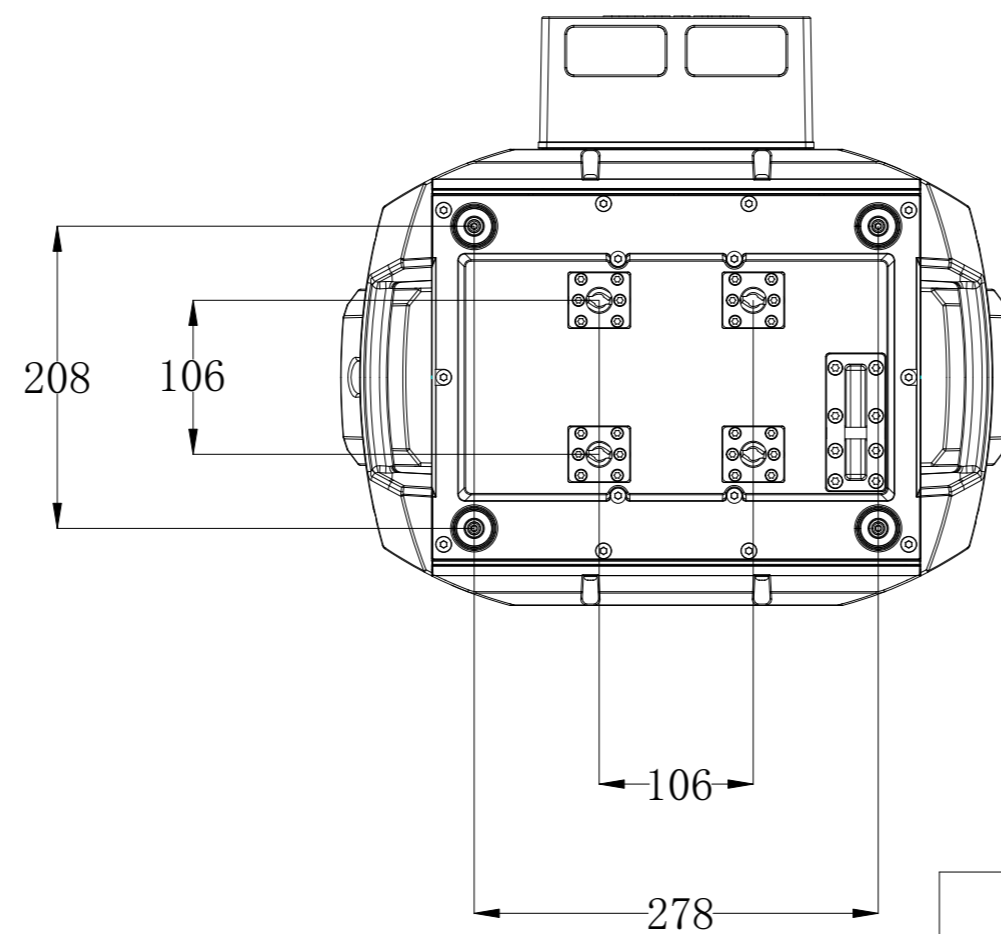
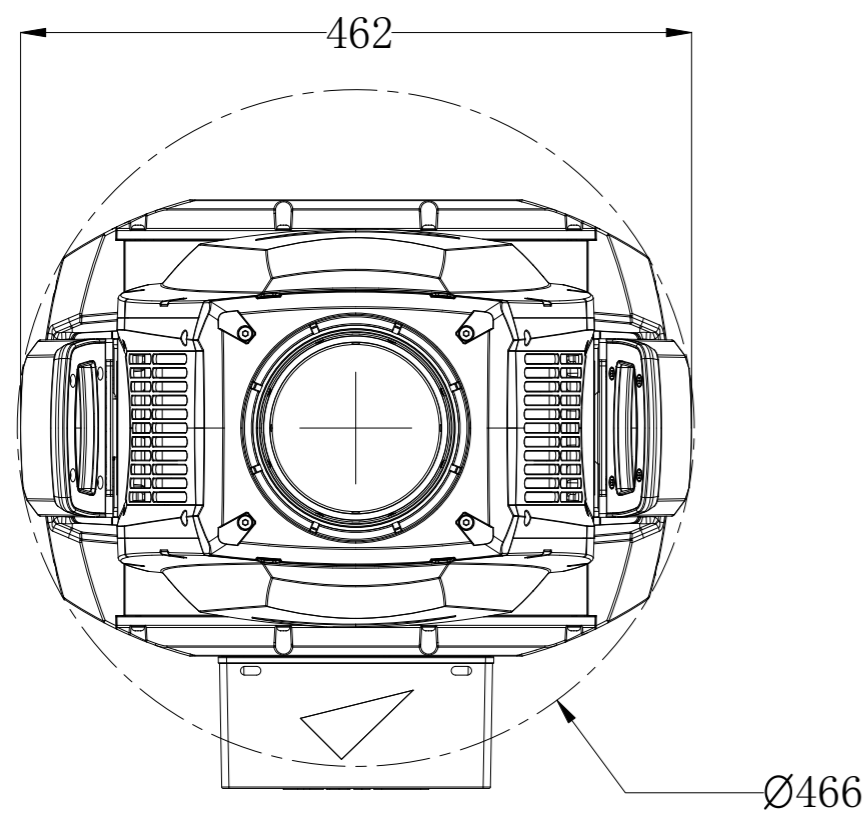
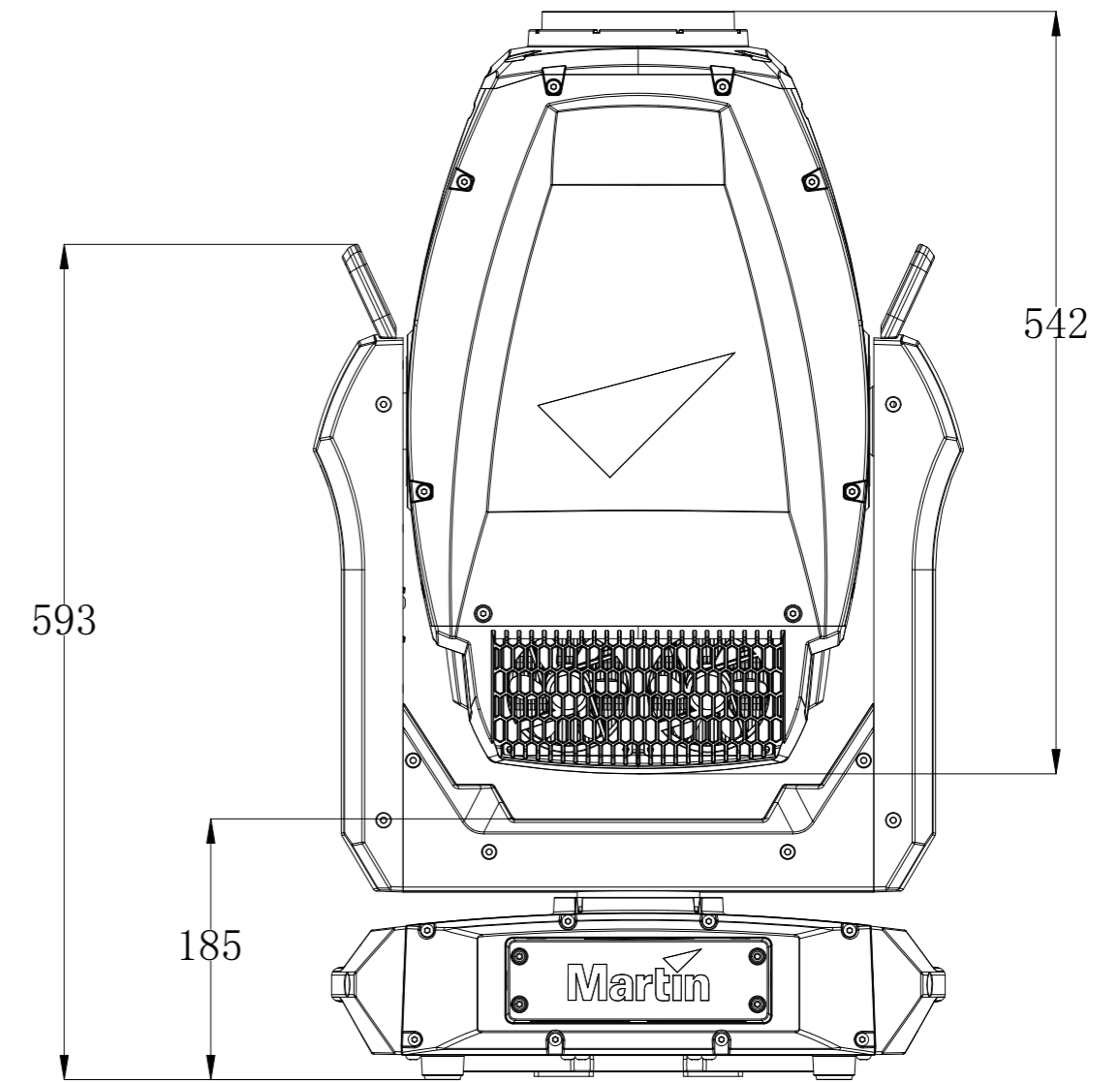

© 2020 HARMAN Professional Denmark ApS PROPRIETARY AND CONFIDENTIAL PROPERTY OF HARMAN. DO NOT DISCLOSE, REPRODUCE, OR PUBLISH WITHOUT WRITTEN HARMAN APPROVAL. ROHS RESTRICTION OF HAZARDOUS SUBSTANCES ALL MATERIALS USED IN THIS PART MUST BE ROHS COMPLIANT. SUPPLIER SHALL PROVIDE A CERTIFICATE OF ROHS COMPLIANCE WITH THE FIRST ARTICLE.	Material	FIRST ANGLE PROJECTION 		HARMAN Professional Denmark ApS Østfælles Allé 44 DK 8200 Aarhus N
	General linear tolerance			
	General angular tolerance	Color	NO.	REV. A
	General geometrical tolerance	Project number	SIZE A2	SCALE 1:5
	DIMENSIONS SHOWN ARE FOR REFERENCE AND INSPECTION ONLY. REFER TO CAD MODEL PROVIDED WITH THIS DRAWING FOR OVERALL DEFINITION OF PART GEOMETRY.		UNIT mm	DO NOT SCALE DRAWING
			SHEET 1	OF 1