

STI LATCHING/TIMER MODEL LT-1UL

NOTE

It is important to read, understand and follow all instructions provided with this product. It is the installer's responsibility to comply with NFPA 70, 72 & 101, NEC, mounting specifications according to ADA and other applicable codes. This product is not to be used in place of panic hardware. To avoid electrical shock, DO NOT attempt to install this product when power is on. After installation and testing are complete, provide a copy of this manual to all personnel responsible for testing and maintenance of this product.

*For access control installations, power for the LT-1UL Timer must be supplied by a power source Listed to UL294. When used for access control, this device shall be used a part of an access controlled egress door system. It is up to the local AHJ to allow use of this device in place of an automatic sensor. For higher security installations, lower time limits should be used.

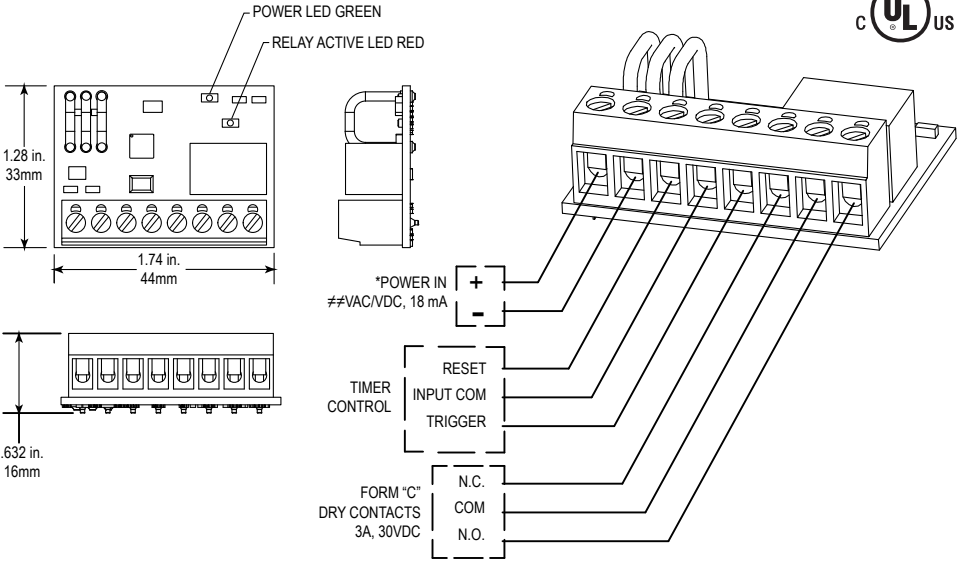

RELAY MODE

Fail Secure (default) – With power to circuit relay is unswitched - Relay terminals as marked on pcb.

Fail Safe - Cut Relay Mode Jumper (see figure below) – Relay switches with power to circuit.

TO CHANGE TIMER SETTINGS (default = 15 seconds): Cut jumpers with "X", do not cut jumpers with "□".

If the trigger is activated during a timing cycle, the timer is restarted.

NOTE To ensure jumpers do not reattach or short to other components, cut jumper off completely flush to PCB.

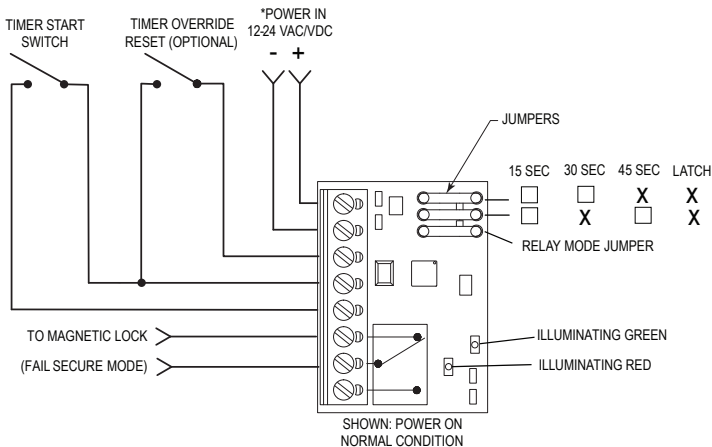

INSTRUCTIONS FOR MOUNTING

1. Locate suitable mounting position in a listed gang box.
2. Using case base as a template, mark and drill (2) 7/64" holes.
3. Attach case base with 2 thread forming screws (included).
4. Install insulation paper.
5. Snap circuit board into place with terminal strip toward case edge with arrow.
6. Snap on case top.
7. Wire devices.

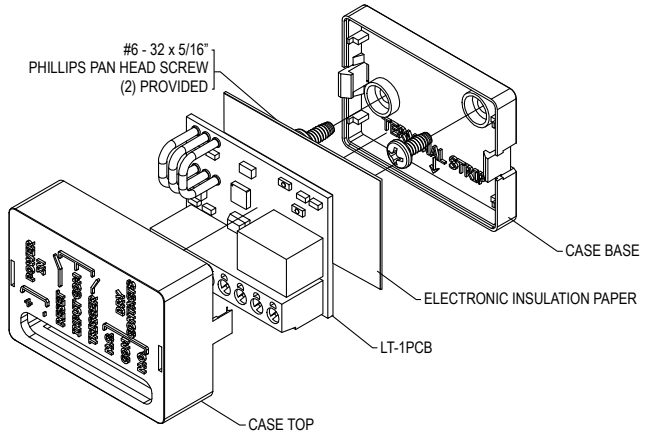

CONTACT RATINGS

Models: UB-1, UB-2, SS2xx4, SS2xx5, SS2xx7 and SS2xxB ending with LTUL Form "C" Contacts are rated 30 VDC, 3A.

UL294 Performance Levels:

Line Security: I
 Attack: I
 Endurance: IV
 Standby Power: I

WARRANTY

One year guarantee on electro mechanical and electronic components.

Electronic warranty form at www.sti-usa.com/wc14.



USA



**Safety Technology
 International**

2306 Airport Rd • Waterford, MI 48327, USA
 Phone: 248-673-9898 • info@sti-usa.com • www.sti-usa.com

Taylor House • 34 Sherwood Road • Bromsgrove, Worcestershire • B60 3DR • England
 Tel: +44 (0)1527 520 999 • info@sti-emea.com • www.sti-emea.com

Unit 7A • Lockhead Avenue • Airport Business Park • Waterford • X91 HWF2 • Ireland
info@sti-emea.com • www.sti-emea.com

