

Double Gang Mounting Box

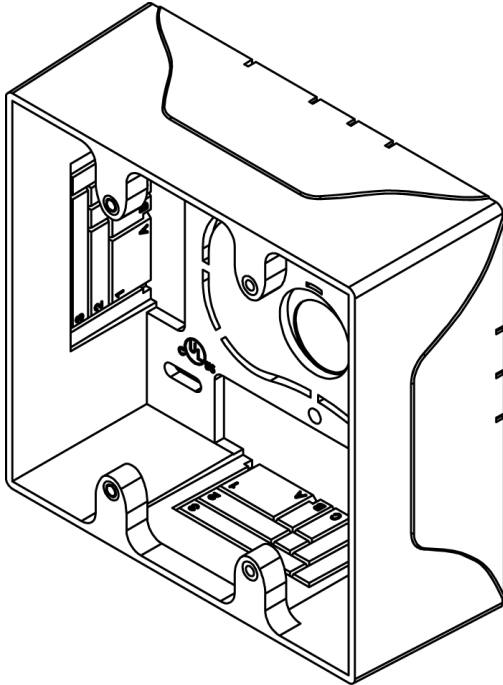

Package Includes

- A. Double Gang Mounting Box, **1 Piece.**
- B. Double Sided Adhesive Strip, **2 Pieces.**
- C. 4" Cable Tie, **4 Pieces**
- D. #6-32 x 3/4" Pan Head, Sharp Point Tapping Screw, **4 Pieces.**

Features and Benefits

- Provides a surface mounted solution for a variety of media, including voice, data, CATV, fiber, audio, video distribution to the work area
- Fits standard NEMA double gang electrical boxes
- Multiple mounting options including adhesive backings and screws
- Integrated internal routing posts and cable management system with evenly spaced cable tie anchor points
- Rear cable entry for clean external appearance
- Rugged and durable construction
- Raceway knockouts integrate with raceway systems
- Used with ICRW11, ICRW12, and ICRW13 raceway systems
- Accommodates all ICC faceplates
- ANSI/TIA-568-C and UL 1863 compliant

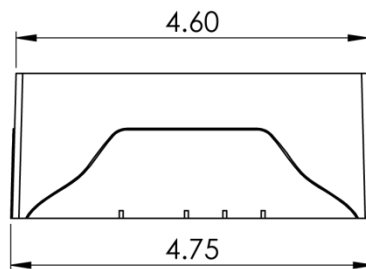
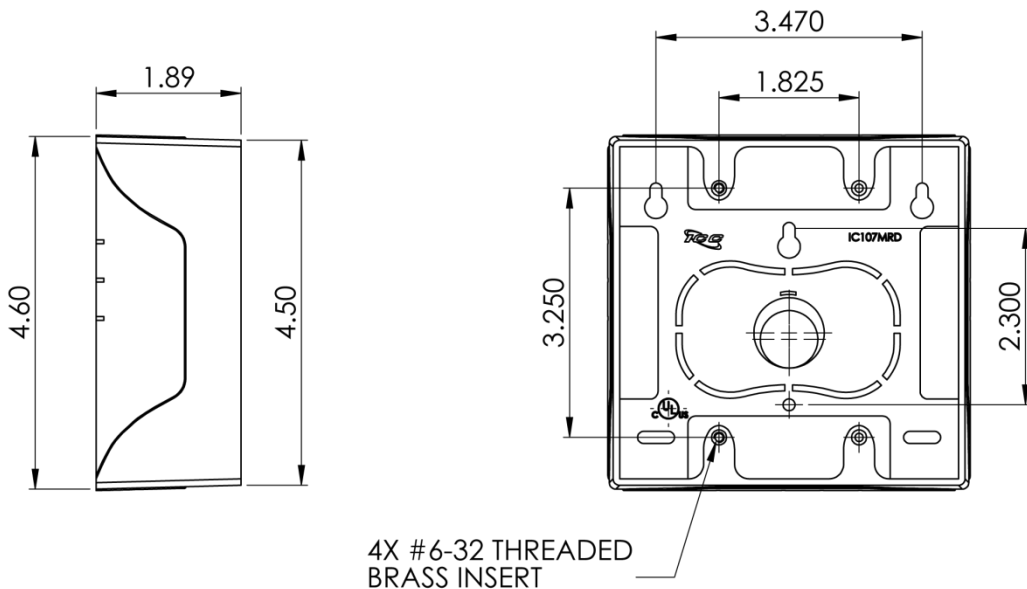

Specifications

- Material: ABS, UL 940V-0
- Surface Finish: Texture
- Color:xx: IV-Ivory, WH-White

Raceway Knockout Charts

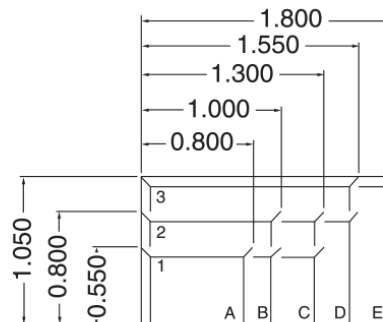

ICACSMBS
 ICACSMBD
 IC107MRS
 IC107MRD

