

Installation Instructions

Refer to Supplemental Information (next page) for complete descriptions of these installation steps

FG-1615/FG-1615T Glassbreak Detector

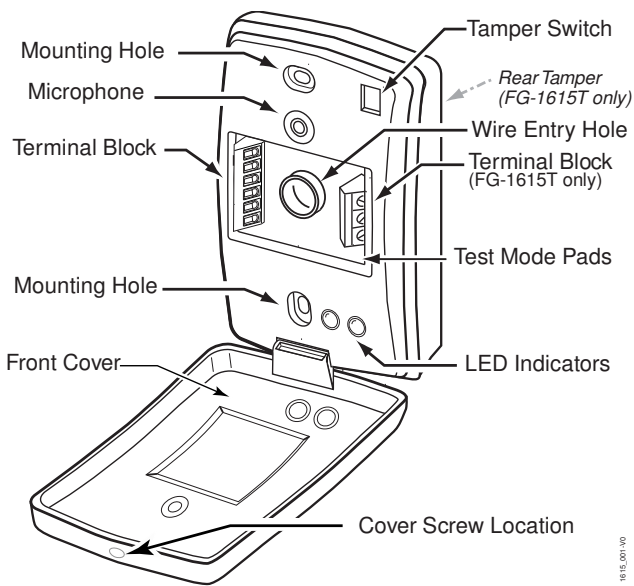

Select Mounting Location

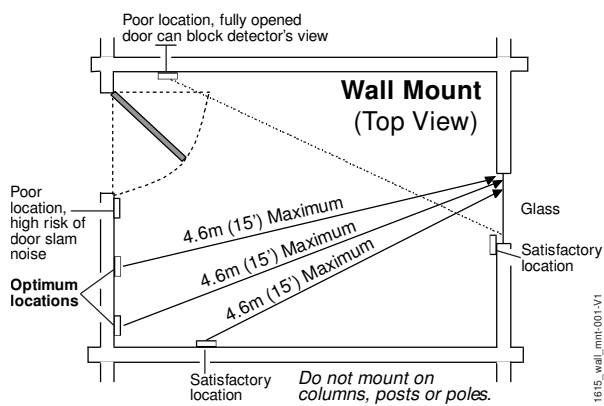

Test Location w/ 9V Battery

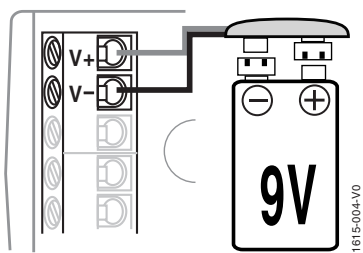

Enable Wall Tamper (FG-1615T Only)

- Remove plastic tab from rear of detector.
- Install wall tamper screw as shown.
- Set screw depth to make contact w/ bottom of tamper cavity when device is installed

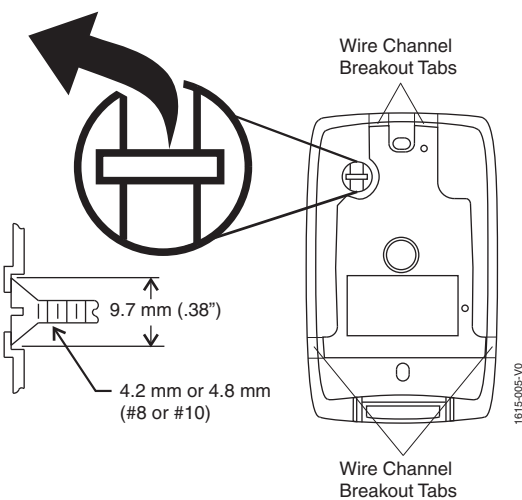

Connect Detector

Connect detector using 18 to 22 AWG wire, with ends stripped approximately 6mm (1/4 in.) Use the appropriate wiring method as shown in these diagrams:

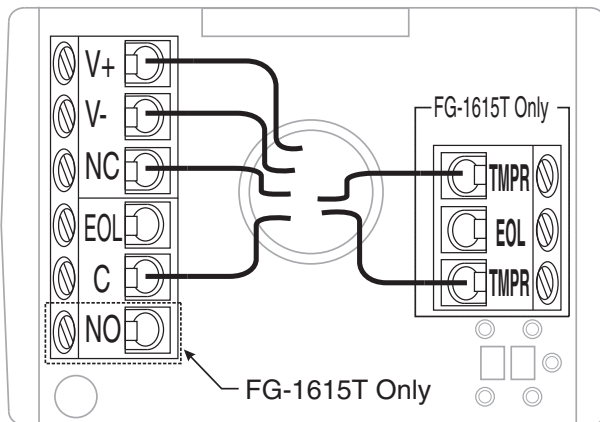

Normally Closed Loop/No EOL Resistor

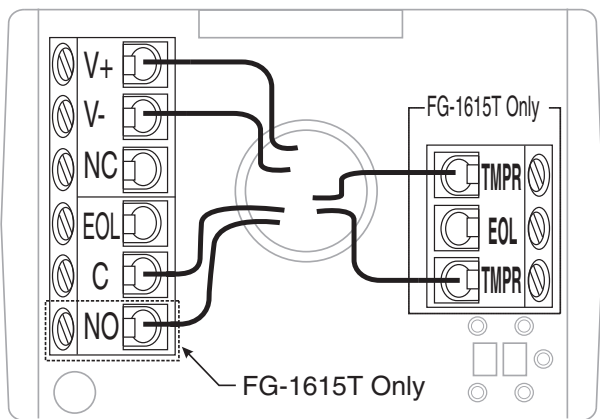

Normally Open Loop/No EOL Resistor

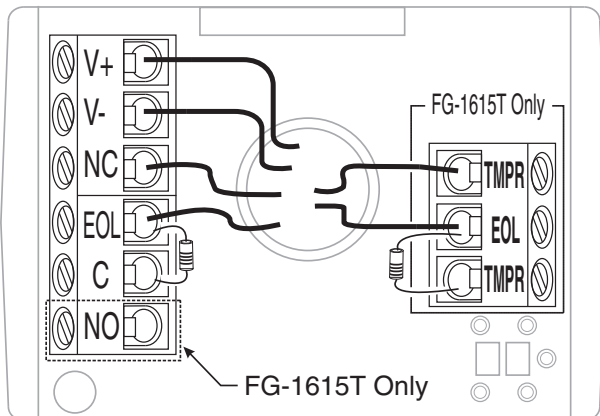

Normally Closed Loop/With EOL Resistor

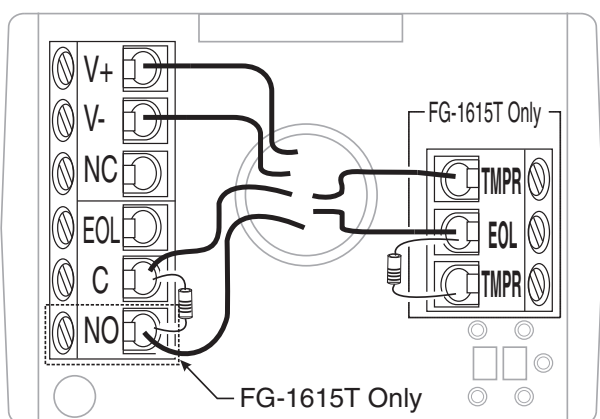

Normally Open Loop/With EOL Resistor

Mount Detector

- Place unit over wall tamper screw, if used!
- Use mounting holes as template to mark ceiling or wall.
- Mount detector using appropriate hardware.

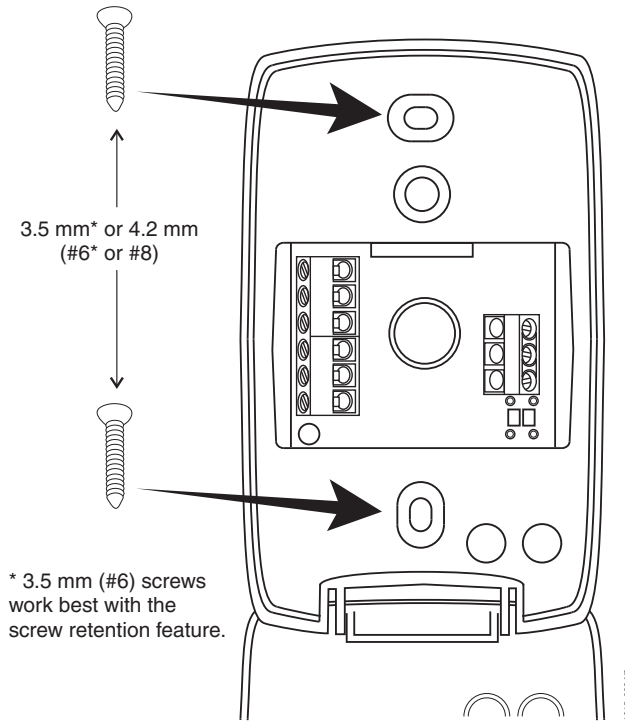

Test Detector Installation

Enter Test Mode using FG-701 (see Testing the Detector on the next page), or enter manually by temporarily shorting the Test Mode pads as shown below.

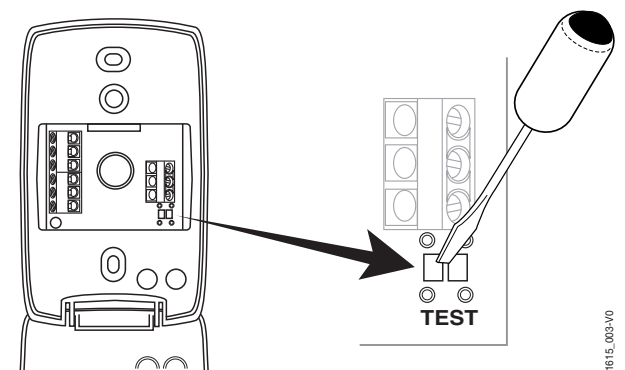

Install Cover Screw (optional)

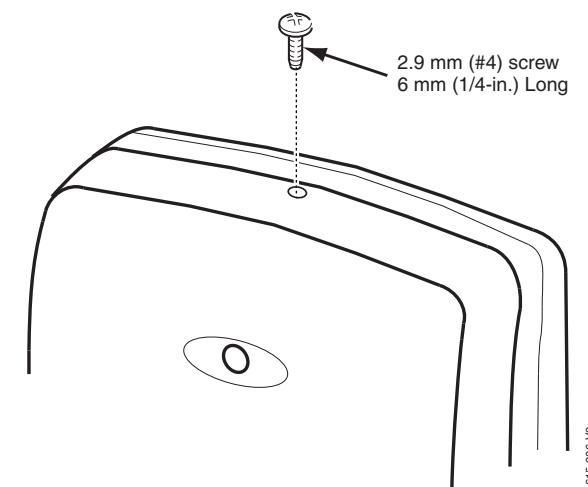

1. General Information

The FG-1615/FG-1615T glassbreak detector senses the sound of breaking plate, tempered, laminated, wired, coated and sealed insulating glass.

These products are both UL and ULC listed.

2. Choosing Mounting Location

The preferred mounting location for the device is on a wall or ceiling, opposite the protected glass.

For the best detector performance, select a mounting location that is:

- within 4.6 m (15 feet) of the protected glass;
- within clear view of the protected glass;
- at least 2 m (6.5 feet) from the floor;
- at least 1 m (3.3 feet) from forced air ducts;
- at least 1 m (3.3 feet) from sirens or bells greater than 5 cm (2 inches) in diameter.
- between the protected glass and any heavy window coverings that may be present. Alternatively, when heavy window coverings are present, the detector can be mounted on the frame of the window.

Avoid mounting the detector on the same wall as the protected glass, on free-standing posts or pillars, or in rooms with noisy equipment (air compressors, bells, power tools, etc.), if this equipment is operated when the detector is armed.

3. Testing Mounting Location With 9V Battery

You may test the detector in the desired mounting location before drilling/wiring. *If the 9V battery cannot supply sufficient power, the detector will not operate, and the red and green LEDs will flash on/off.*

Follow the procedure described in "Testing the Detector" (next column) to confirm proper operation.

4. Sensitivity (Range)

The sensor range is set at 4.6 m (15 feet) maximum and is not adjustable. Verify the range with the FG-701 Glassbreak Simulator (see Testing the Detector).

5. ALARM LATCH LED INDICATOR

Both LED indicators are in standby mode, ready to be enabled. The red LED indicator latches **ON** when the detector goes into alarm. (Alarm relay timing is not affected by the latched Alarm LED.) Refer to item 10 for complete LED operation.

To reset the alarm LED, remove/restore power or toggle the detector in and out of Test Mode (refer to item 9).

6. Enabling Optional Rear Tamper (FG-1615T only)

The **FG-1615T** detector is equipped with a combination normally-closed (NC) cover and wall tamper switches. Each unit is shipped with the cover tamper operational, and the wall tamper disabled.

To enable the rear tamper, remove the plastic tab on the back of the detector, using needle-nose pliers. The wall tamper arm will then extend through the hole. *Proceed with the following mounting instructions to install the wall tamper screw.*

7. Mounting the Detector

Note: If ceiling mounted, the end with the hole (microphone end) should face the glass being protected.

1. If using optional Wall Tamper (FG-1615T):

Mark the mounting location for the wall tamper screw based on the final location of the detector. Then, install the wall tamper screw so that it will just make contact with the bottom of the tamper cavity when the unit is mounted. *Use a flat head 4.2 mm or 4.8 mm screw (#8 or #10).*

2. Position the unit over the wall tamper screw (if used), then mark the mounting screw and wire openings. *If required by the location, install wall anchors for the mounting screws.*

3. Secure the unit to the wall or ceiling, oriented so the microphone has the best line-of-sight to the protected glass.

8. Wiring the Detector

Refer to the wiring diagrams (page 1) to select the appropriate wiring configuration.

NOTE: This sensor must be connected to a UL Listed power supply or UL Listed control unit capable of supplying a minimum of four hours of standby power.

9. Testing the Detector

The detector should be tested at least once each year. Test the detector with the FG-701 Glassbreak Simulator. The model FG-700 Glassbreak Simulator can also be used if it is set for the TEMPered glass sound. Other simulators will not give accurate indication of range.

To enter Test Mode manually:

1. Open the front cover.
2. Use a screwdriver to temporarily short the two Test Mode pads on the PC board (see diagram on previous page).
3. Close the front cover.

The detector's green LED blinks approximately once per second to indicate that it has entered Test Mode.

To enter the Test Mode with the FG-701:

1. Stand within 3 m (10 feet) of the detector.
2. Switch the FG-701 to ACTIVATE and MANUAL modes.
3. Point the front speaker of the glassbreak simulator towards the detector. Press the red START button to send a short activation code.

When the detector enters Test Mode, the green LED on the detector flashes about once per second. If the green LED does not flash, move closer to the detector and repeat the procedure.

Testing the Detector (flex and audio signals):

To test the FG-1615/FG-1615T glassbreak detectors, do the following:

1. Place the detector in Test Mode.
2. Set the FG-701 switches to the TEST and FLEX positions.
3. Position the FG-701 near the farthest point of the protected glass and point the speaker directly at the detector. If window coverings are present, close them fully and hold the FG-701 between the coverings and the protected glass.
4. Press the red START button. The simulator clicks on and starts an 8-second armed period.
5. Generate a flex signal by carefully striking the glass with a cushioned tool. The FG-701 responds with a burst of glassbreak audio.

If the detector receives both the flex and audio signals properly, its red Alarm LED lights. (Red Alarm LED does not latch in Test Mode).

Testing the Detector (audio signals only):

The FG-701 can also be used to test the detector's ability to receive audio signals only. See the FG-701 Operating Instructions for additional information. When it receives the audio signal, the detector flickers its green Event LED.

Exiting Test Mode:

When you have finished testing, exit Test Mode by following the same procedure used to enter Test Mode (either using the FG-701 Glassbreak Simulator or temporarily shorting the two TEST pads manually).

The FG-1615/T automatically exits Test Mode after five minutes if no events are detected.

10. LED Indicators

The detector is equipped with two LEDs: a green Event LED and a red Alarm LED. When the LEDs are enabled, they light in a variety of patterns to convey the detector's operational status. The following table summarizes the LED messages.

CONDITION	GREEN LED	RED LED
Normal	OFF	OFF
Normal, event detected	Flicker	OFF
Normal, alarm LED latched	OFF	ON
Power up	ON 1 second	ON 1 second
Low Voltage	Flash ON/OFF	Flash ON/OFF
Test Mode	Flash once per sec	OFF
Test Mode, event detected	Flicker	OFF
Test Mode, alarm	Flash once per sec	ON 5 seconds

11. Cover Screw

The front cover can be secured after installation. To do so, remove the cover breakout flash and secure the front cover with a 2.9 mm x 6.0 mm (#4 x 1/4") screw.

12. Nominal Glass Thickness Chart

Glass Type*	Nominal Thickness	
	Minimum	Maximum
Plate ^{3a}	2mm (3/32 in.)	10mm (3/8 in.)
Tempered	3mm (1/8 in.)	10mm (3/8 in.)
Laminated ¹	3mm (1/8 in.)	14mm (9/16 in.)
Wired	6mm (1/4 in.)	6mm (1/4 in.)
Coated ^{2,3b}	3mm (1/8 in.)	6mm (1/4 in.)
Sealed Insulating ^{1,3b}	3mm (1/8 in.) [13mm (1/2 in.) overall]	6mm (1/4 in.) [19mm (3/4 in.) overall]

* Minimum size for all types is 28cm (11 in.) square; glass must be framed in the wall or mounted in a barrier at least 0.9m (36 in.) wide.

¹ Protected only if both plates in the unit are broken

² Coated glass with security films up to 0.35mm (14 mils) thick (including films for solar protection) may be used. Evaluated with these products: 3M® SCOTCHSHIELD® SH14CLARL – 0.35mm (14 mils), 4 ply film; Film Technologies International, Inc.'s GLASS-GARD GGLL 1200 has been evaluated with this product by Underwriters Laboratories, Inc.

³ In compliance with Underwriters Laboratories of Canada's Standard for Intrusion Detection Units (CAN/ULC-S306-M89):

- a. Plate glass 3mm (1/8 in.) to 10mm (3/8 in.) can be used.
- b. ULC recognizes a maximum range for protecting sealed insulating glass and coated glass of 2.3m (7.5 ft.).

13. Specifications

Range:

4.6 m (15 ft.) maximum, omnidirectional
No minimum range

Operating Temperature:

-10° C to 55° C
(14° F to 131° F)
UL: -10° C to 50° C
(-14° F to 122° F)
(Indoor use environment)

Storage: -20° C to 55° C
(-4° C to 131° F)
UL: -10° C to 50° C
(-14° F to 122° F)

Alarm Duration:

5 seconds (unaffected by alarm LED latching)

Alarm Relay:

FG-1615 Form A
FG-1615T Form C
100 mA maximum
25 VDC maximum
ON/closed 22Ω ±6Ω
OFF/open >1MΩ

Tamper Switch: FG-1615T Only

Combination cover/ wall tamper
25 mA maximum
24 VDC maximum

RFI Immunity:

30 V/m,
10 MHz - 1000 MHz

ESD Immunity:

10 kV discharges of either polarity to exposed surfaces

Power Requirements:

6 - 18 VDC; 12 mA typical at 12 VDC,
22 mA max, (Latched LED)

AC Ripple: 4 Volts peak-to-peak at Nominal 12 VDC

Dimensions:

115 mm x 72 mm x 27 mm
(4.5 in. H x 2.8 in. W x 1.05 in. D)

Weight:

98 g (3.5 oz.)
Packaged Product: 126 g (4.5 oz.)

Approvals / Listings:

FCC and IC verified,
CE, C-Tick,
UL Listed, ULC Listed

FG-1615T Only

EN 50131-1 Security
Grade 2, Environmental
Class II

For connection to an
EN60950 Class II Limited
Power Source



Responsible Party / Issuer of Supplier's Declaration of Conformity: Ademco Inc., a subsidiary of Resideo Technologies, Inc., 2 Corporate Center Drive., Melville, NY 11747, Ph: 516-577-2000

For any additional information regarding the compliance of this product to any EU specific requirements, please contact –

Sécurité Communication
1198, Avenue du Docteur Maurice Donat
BP 1219 - 06254 MOUGINS CEDEX, FRANCE
Tel.: +33 (0)4 92 94 29 50
fax: +33 (0)4 92 94 29 60.

NOTICES

FCC NOTICE: This device complies with Part 15 of the FCC Rules. Operation is subject to the following two conditions: (1) This device may not cause harmful interference, and (2) this device must accept any interference received, including interference that may cause undesired operation.

The user is cautioned that changes or modifications not expressly approved by Resideo could void the user's authority to operate this equipment.

Note: This equipment has been tested and found to comply with the limits for a Class B digital device, pursuant to part 15 of the FCC Rules. These limits are designed to provide reasonable protection against harmful interference in a residential installation. This equipment generates, uses, and can radiate radio frequency energy and, if not installed and used in accordance with the instructions, may cause harmful interference to radio communications. However, there is no guarantee that interference will not occur in a particular installation. If this equipment does cause harmful interference to radio or television reception, which can be determined by turning the equipment off and on, the user is encouraged to try to correct the interference by one or more of the following measures: 1) Reorient or relocate the receiving antenna, 2) Increase the separation between the equipment and receiver, 3) Connect the equipment into an outlet on a circuit different from that to which the receiver is connected. The installer can also consult an experienced radio/television technician for additional suggestions, if necessary.

IC Notice: This Class B digital apparatus complies with the Canadian ICES-003.

Cet appareil numérique de la Classe B est conforme à la norme NMB-003 du Canada.

This product is manufactured by Resideo and its affiliates.

resideo

2 Corporate Center Drive, Suite 100
P.O. Box 9040, Melville, NY 11747

© 2020 Resideo Technologies, Inc.
www.resideo.com

SUPPORT & WARRANTY

For the latest documentation, online support, warranty, and patent information please go to:
www.resideo.com

