

**Overview**

The HPX-600/900/1200-NA family of HydraPort Connection Ports (AMX-FG560-xyz-NA) is built to accommodate the diverse connection needs of conference and meeting room visitors. The HPX-600/900/1200-NA are designed to be mounted into a horizontal surface such as a conference room table or lectern in order to provide connectivity for power, networking, audio/video and control.

Specific connectivity is accomplished by populating the HydraPort Base Assembly with various modules. Each base includes a single US/NAM power outlet module already installed.



FIG. 1 AMX HydraPort Base Assembly

AMX offers six (6) versions of the Hydraport Base Assembly for North America:

HPX-600/900/1200-NA HYDRAPORT BASE ASSEMBLIES		
HPX-600BL-NA	AMX-FG560-01B-NA	6M Capacity, Black
HPX-600SL-NA	AMX-FG560-01S-NA	6M Capacity, Silver
HPX-900BL-NA	AMX-FG560-02B-NA	9M Capacity, Black
HPX-900SL-NA	AMX-FG560-02S-NA	9M Capacity, Silver
HPX-1200BL-NA	AMX-FG560-03B-NA	12M Capacity, Black
HPX-1200SL-NA	AMX-FG560-03S-NA	12M Capacity, Silver

**ATTENTION:** Each base assembly comes with one (1) US/NAM (Type A/B) power outlet, pre-installed. In North America, only one (1) power outlet may be installed in any Hydraport Base Assembly.

**ATTENTION:** Only a professional, AMX-qualified installer should perform this installation. Installation must conform to all local codes. This product may not be installed by the end-user.

**Accessories**

Hydraport Base assemblies come with the following accessories:

- Two (2) Table Spacers (for use in tables 0.5"-0.75" thick) w/ adhesive
- Eight (8) Cable Routing Clips

**Compatible HydraPort Modules**

Please refer to the **Architectural Connectivity** product pages at AMX.com for a complete listing of compatible HydraPort Connection Modules

**Installation of the HydraPort Base Assembly**

The following sections describe the preparation, installation and setup of the HydraPort Base Assembly. A typical installation will include several various HydraPort modules.

Each HydraPort module has specific instructions for terminating their connections. Refer to each module's installation guide during the installation of the HydraPort system.

*Note: Read these instructions in their entirety before beginning the installation. The installation requires specific steps to be performed in specific order.*

**CAUTION:** This installation requires specific woodworking skills. This installation should be performed by an experienced person, comfortable with these types of woodworking operations. Improper installation may result in damage to the mounting surface. AMX is not responsible for damage caused by improper installation.

**1) Select a Suitable Location for the HydraPort Base Assembly**

The following table indicates the space requirements for installing the unit:

MODEL	HEIGHT	WIDTH	LENGTH
HPX-600BL-NA	Base Height: 4.37" (111 mm)	5.43" (138 mm)	8.19" (208 mm)
HPX-600SL-NA			11.14" (283 mm)
HPX-900BL-NA			14.09" (358 mm)
HPX-900SL-NA	With RCMs: 11.3" (287 mm)	5.43" (138 mm)	8.19" (208 mm)
HPX-1200BL-NA			11.14" (283 mm)
HPX-1200SL-NA			14.09" (358 mm)

The HydraPort system requires a mounting surface from 0.5" (13mm) to 2" (51mm) thick. Thin surfaces may require use of included spacers.

*Note: Care should also be taken to ensure that the HydraPort system does not interfere with the normal use of the work space. For example, on a table or work surface, ensure that the system does not interfere with the user's legs when they are seated at the table.*

**2) Cut the Hole in the Mounting Surface**

The Hydraport Base Assembly includes a paper template to locate the ideal installation spot, and to mark the perimeter for cutting the surface. The following table provides the hole cutout dimensions for the HydraPort Base Assembly:

MODEL	WIDTH	LENGTH
HPX-600BL-NA	4.84" (123 mm)	7.64" (194 mm)
HPX-600SL-NA		10.59" (269 mm)
HPX-900BL-NA		10.59" (269 mm)
HPX-900SL-NA		13.54" (344 mm)
HPX-1200BL-NA		13.54" (344 mm)
HPX-1200SL-NA		13.54" (344 mm)

1. Use the template or measure the tabletop or other mounting surface to locate the desired position of the HydraPort Base Assembly.
2. Use the cutout template to mark the edges of the cutout.

*Note: Very little clearance exists between the HydraPort Base Assembly and the hole cutout in the mounting surface.*

Tips & Considerations:

- Align the cutout carefully with the edges or other features of the mounting surface. If the cutout is misaligned, the installed unit will be misaligned.
- Take care to ensure that the top of the mounting surface is not damaged beyond the width of the trim bezel as the cutout is made.
- Use an appropriate drill & bit to make a starting hole within the boundary of the cutout. Use an appropriate saw, such as a jigsaw to finish the cutout.
- Make sure cutting tool used is appropriate for the material to be cut and will not tear or chip the top surface.
- Note that the process of making the cutout will create substantial dust and prepare the environment appropriately.

**3) Prepare the Terminations**

Some HydraPort modules require some type of backside termination.

*Note: Refer to the installation guide for each module to determine the required backside termination.*

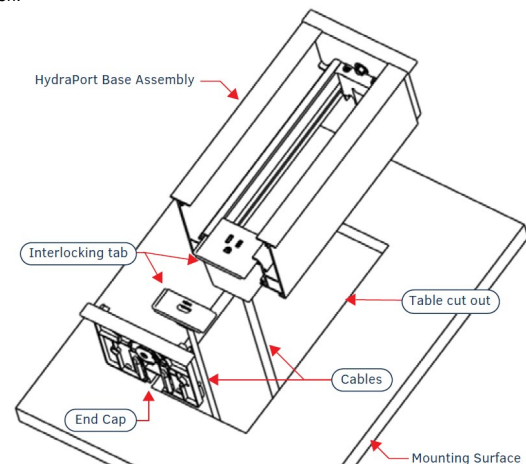

FIG. 2 Inserting the Modules to HydraPort Base Assembly

- The backside termination for each module can & should be completed before the module is installed into HydraPort Base Assembly.
- For terminations for which the far end of the cable is not accessible (either because the cable has been run under carpet, in a conduit or structure, or is otherwise fixed), the cable must be placed through the cutout in the table prior to installation, as indicated in FIG. 2.

#### 4) Insert the HydraPort Modules

Note: The socket-outlet (Connection to Mains Power branch circuit) shall be installed near the equipment and shall be easily accessible.

Note the orientation of each HydraPort Module - a small tab exists on one side of the faceplate of each module that fits tongue-in-groove into the next module. Ensure all tabs are facing the same direction (see FIG. 2).

1. Remove one end cap of the HydraPort Base Assembly by removing the six sheet metal screws and one pivot screw and pivot pawl assembly.
2. Slide the pre-terminated modules, one at a time, into the HydraPort Base Assembly, and route the cables from each module out the bottom.
3. Use cable ties and one or more of the sliding clips to secure the cables as needed to the HydraPort Base Assembly.
4. Reinstall the end cap of the HydraPort Base Assembly by installing the six sheet metal screws and one pivot screw and pivot pawl assembly.

Note: Do not over-tighten the pivot pawl screw (i.e., do not use a high-powered drill to tighten this screw).

#### 5) Install Completed System Into the Mounting Surface

1. Install the unit into the cutout in the mounting surface.
  - Make sure that all cables from the backside terminations pass through the cutout.
  - For terminations for which the far end of the cable is not accessible (either because the cable has been run under carpet, in a conduit or structure, or is otherwise fixed), the cable must be placed through the cutout in the table prior to installation, as indicated in FIG. 5
2. Open the door and rotate the four mounting screws located inside and at each end of the HydraPort base assembly in order to rotate the retaining tabs out under the mounting surface.

Note: Make sure that the retaining tabs are down and folded out of the way prior to installing the unit in the mounting surface.

3. Carefully tighten the mounting screws until the mounting tabs contact the backside of the mounting surface and torque to 8 in-lbs (FIG. 3). It will be necessary to flip the cover to the opposite side to access the other two screws.

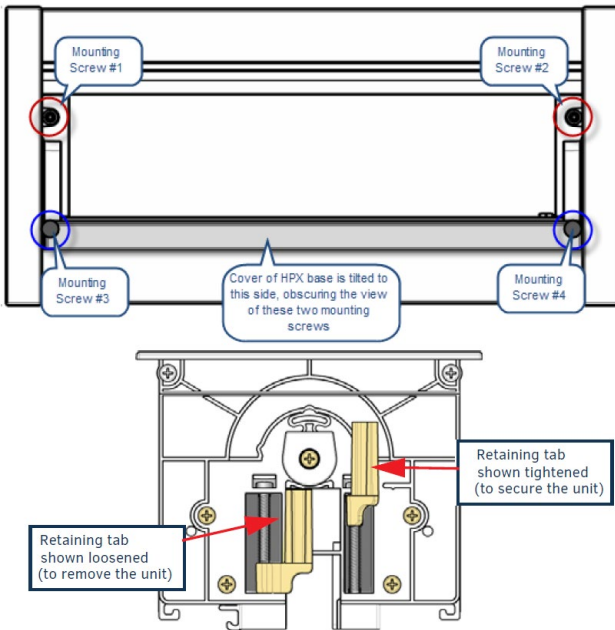

FIG. 3 HPX Base Assembly (shown mounted) – Mounting Screw Locations

Note: Do not over torque screws. To avoid damaging the mounting tabs, use a hand  
 Note: For surfaces less than 3/4" (19mm) thick, use the supplied plastic spacers by fixing them to each end of the cutout using the supplied double sided tape (FIG. 4).

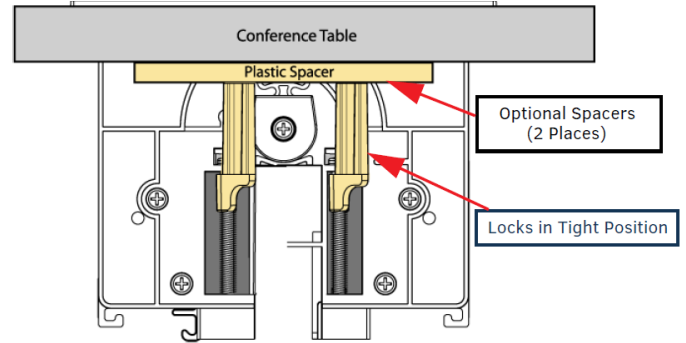

FIG. 4 Optional Spacer and Mounting Tabs Deployed

#### 6) Install the System into the Mounting Surface

1. Terminate the underside connections as required for each cable exiting the HydraPort system.
2. Secure these cables and the power cable to either of the end caps using the supplied wire ties (FIG. 5).

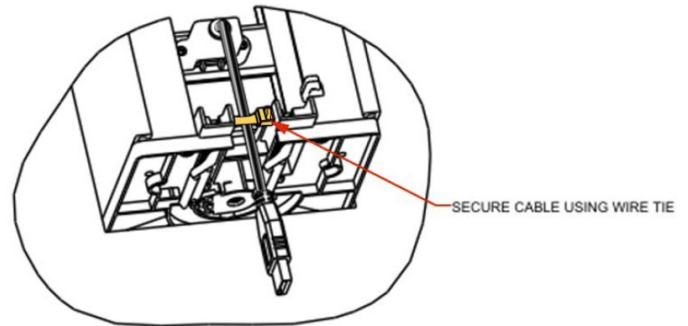

FIG. 5 Optional Spacer and Mounting Tabs Deployed

3. Secure the cables in at least one additional location after they have been secured to the system to prevent undue stress if the cables are inadvertently kicked, snagged or pulled. Routing clips are provided that slide into the bottom channel of the base assembly and leave a gap to hold the cable (FIG. 6). These clips come in two different sizes, the larger gap is for the thicker RGB+A RCM cable.

Using the top tab & slot, insert the panel to the mounting bracket. Make sure the tabs are fully engaged.

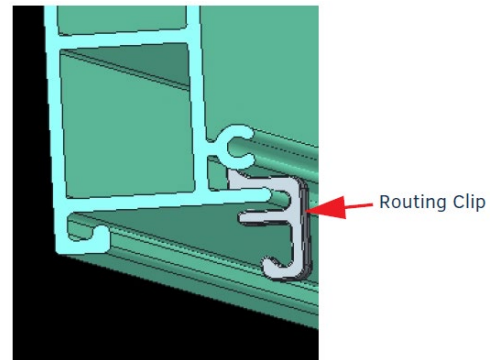

FIG. 6 Bottom View with Cable Routing Clip Installed

#### Additional Documentaiton

For more detailed installation instructions with additional drawings, please refer to the HPX-600/900/1200 Installation Guide, available to view or download from AMX.com.

