



NAPCO SECURITY TECHNOLOGIES, INC.
333 Bayview Avenue, Amityville, New York, U.S.A. 11701
800-645-9445 (631) 842-9400 FAX (631) 842-9137
Note: Technical Service is for alarm professionals only

NAPCO Tech Support

TECH TIP



Date: Thursday, July 21, 2016

Subject: How do I wire my carbon monoxide (CO) zone on a GEM-CO-MOD to an output on a Gemini GEM-P3200, GEM-P9600 and/or a GEM-X255 control panel?

Models: **GEM-CO-MOD Carbon Monoxide** detector, Gemini **GEM-P3200, GEM-P9600, GEM-X255** control panels

The **GEM-CO-MOD** requires an output to trip the carbon monoxide (CO) zone. The diagram below illustrates the correct connections from the positive CO zone (labeled **COZ+**) to a PGM terminal located on the **GEM-P816, GEM-P1632** or the **GEM-P1664** control panels. Program the PGM to activate the zone.

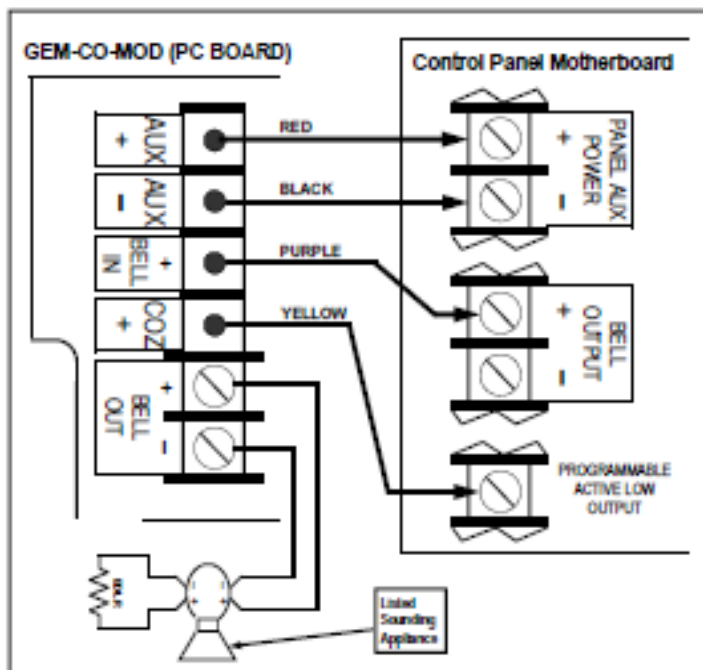

With the **GEM-P3200, GEM-P9600** or the **GEM-X255** control panels, wire the positive CO zone (labeled **COZ+**) to the fire output **E9** lug. After wiring, enable the fire output to activate the zone.