

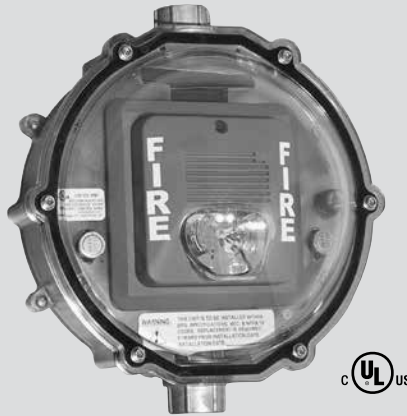

**Safety Technology  
International**

# Stopper Dome Heated Enclosure

STI-1229HTR/STI-1229HTR240  
STI-1229HTR-WD/STI-1229HTR240-WD



## Features

- Maintains operating strobe appliance temperature with external temperatures to  $-70^{\circ}\text{F}$  ( $-57^{\circ}\text{C}$ ). Independently tested to  $-102^{\circ}\text{F}$  ( $-73^{\circ}\text{C}$ ).
- Enclosure tested to NEMA 4X Standards. Equivalent to an IP 66 rating.
- UL, cUL Listed.
- CSFM requires local approval only.
- Protects ADA compliant strobes to UL 1971 Standards.
- Can be used for UL 1638 Strobes for colored lens (see Amseco's spec sheet).

## Operation

For use in areas where temperature or environmental conditions exceed the operational range of fire strobe signaling devices. Unit requires 24 VDC continuous for fan operation and 110 or 240 VAC operation for heater, as well as power for strobe operation and supervision for temperature indicator. Fan runs continuously to maintain uniform temperature. Heater cycles as required to maintain operating temperature range for listed strobes.

**We protect the things that protect you.®**

## Warnings

The enclosure is used to protect UL Listed 1638 and 1971 visual notification appliances at temperatures down to -70°F (-57°C). It is the installer's responsibility to comply with NEC 70 Articles 502 and 503, NFPA 72, and other applicable fire and electrical codes. Conduit or raceway paths need to be sealed as near to the enclosure as possible. Installer should have maintained supervision over the low temperature thermostat. The low temperature monitoring thermostat makes the circuit at +32°F (0°C) and clears the circuit at +50°F (+10°C). This listing requires that the fire alarm supervisory control module be only of the latching type. On the appliance mounting plate is a label where you should record the installation date. Also include below the serial number and installation date on the instruction sheet for quick reference.

Serial Number \_\_\_\_\_

Installation Date \_\_\_\_\_

## MISES EN GARDE

Le boîtier est utilisé pour protéger les dispositifs d'alerte visuelle homologués UL 1638 et 1971 à des températures allant jusqu'à -70 °F (57 °C). Il incombe à l'installateur de se conformer aux articles 502 et 503 de la NEC 70, NFPA 72, et aux autres codes de prévention des incendies et de l'électricité en vigueur. Les chemins des conduites ou canalisations doivent être scellés aussi proche que possible du boîtier. Il est attendu que l'installateur ait effectivement contrôlé le thermostat à basse température. Le contrôle du thermostat à basse température maintient le circuit à 32 °F (0 °C) et déclenche le circuit à 50 °F (10 °C). Cette homologation exige nécessairement que le module de contrôle de la surveillance des alertes d'incendie soit uniquement du type à verrouillage. La plaque de montage de l'appareil comporte une étiquette sur laquelle vous devez enregistrer sa date d'installation. Le numéro de série et la date d'installation doivent aussi être marqués sur la feuille d'instruction pour référence rapide.

Numéro de série \_\_\_\_\_ Date d'installation \_\_\_\_\_

REMARQUE : La tension de service du STI-1200A-HTR est de 110 VCA. La tension de service du STI-1200A-HTR240 est de 240 VCA.

## Installation Notes

1. The enclosure is rated to protect signaling appliances indoors and outdoors and in areas of direct weather exposure.
2. When covering fire-signaling appliances with the enclosure, some light loss occurs. Please follow the guidelines listed during installation.
3. Strobe light loss values for respective manufacturers are shown on page 3. To determine the new composite candela value of the use with the guard refer to the sample calculation shown on page 3 for a manufacturer's strobe.
4. Record the manufacturer's candela value as "A" and the light loss value as "B" and the assembly value as "C". Example: A 60 candela strobe with a 30% light loss transmission value. Value "A" is now 60. Value "B" is (60 times 30% or 0.30) in this case 18.
5. Now value "C" is value "A" minus value "B" or  $60 - 18 = 42$  candela light source. Now refer to NFPA tables for proper room size that newly established value "C" will work in. Then submittal installation drawings must show the composite candela value in this example 42.
6. On a multiple candela value strobe such as 15/30/75 a calculation must be done for each value and the drawing notation composite value for each number on the strobe.
7. All field wiring within this enclosure must be rated for a minimum operating range of 0°C - 110°C.

## Remarques sur l'installation

1. Ce boîtier est homologué pour protéger les appareils de signalisation d'incendie à l'intérieur et à l'extérieur ainsi que dans les zones d'exposition directe aux intempéries.
2. Lors de l'exécution des essais périodiques, et dans le cas où l'atmosphère est poussiéreuse ou de la poussière est soufflée par le vent, vous devez couvrir les ports de la grille de retour afin de minimiser l'infiltration de la poussière ou du sable. Pour éliminer les particules de poussière ou de sable accumulées, utilisez de petits contenants à air comprimé qui servent pour le nettoyage de l'électronique.
3. Les valeurs de perte de lumière stroboscopique publiées par les fabricants respectifs sont présentées à la page 3. Pour déterminer la nouvelle valeur candéla composite pour une utilisation avec une protection, reportez-vous au modèle de calcul montré à la page 3 pour le stroboscope d'un fabricant donné.
4. Inscrivez la valeur candéla « A » du fabricant et la valeur de perte de lumière « B » et la valeur de l'ensemble « C ». Par exemple, la « Société modèle » possède un stroboscope de 60 candélas avec une valeur de perte de diffusion lumineuse de 30 %. La valeur « A » sera alors de 60. Et la valeur « B » sera dans ce cas de 18 (60 fois 30 % ou 0,30).
5. À présent, la valeur « C » est égale à la valeur « A » moins la valeur « B », ou  $60 - 18 = 42$  candélas. Reportez-vous maintenant aux tableaux de la NFPA pour la taille correcte de la pièce compatible avec la valeur « C » nouvellement créée. "C" travailler. Les schémas d'installation à soumettre doivent afficher la valeur de candéla composite comme étant 42.
6. Dans le cas d'un stroboscope à valeur candéla multiple, telle que 15/30/75, un calcul doit être effectué pour chaque valeur et pour la valeur composite du schéma des cotes relatif à chaque valeur sur le stroboscope.
7. Tout le câblage existant à l'intérieur de ce boîtier doit être homologué pour une plage de service minimale de 0 °C - 110 °C.

## Performance Review Manufacturer

	Light Loss %
SYSTEM SENSOR (P2, PC2, P4, PC4, SX, SC)	28%
WHEELLOCK (RSS 24MCW)	31%
ADT SECURITY (ADTG1-V Series), EST/EDWARDS (G1-V, G1-HV, G1-HOV, EG1-V, EG1-HV, EG1-HOV Series), HONEYWELL (XLSG1-V, XLSG1-HV Series), MIRCOM (MG1-V, MG1-HV, MG1-HOV, Series), MIRTONE (MG1-V Series), SIEMENS (G1-V Series)	32%
FARADAY LLC (2700), SIEMENS (U-MCS Series)	33%
EST/EDWARDS (2440S, 202 Series), HONEYWELL (XLS202 Series), MIRCOM(MS Series), SIEMENS (202), ZITON PTY LTD (ZG1-V Series)	34%
SYSTEM SENSOR (SS24110ADA)	36%
AMSECO (SL24W-153075), AMSECO - COLORED LENSES (SL24W-153075 A, B, G or R, SL24C-3075110 A B, G or R, CSL24W-A, B, G or R, CSL24C-A, B, G or R), HONEYWELL (XLSG1-HOV Series), MIRCOM (FS-240), POTTER ELECTRIC (AS-24-153075R, AS-24-	37%

**NOTE** Can be used for UL 1638 Strobes for colored lens (see Amseco's spec sheet).

## Polycarbonate Cleaning Instructions

Rinse with water to remove abrasive dust and dirt. Wash with soap or mild detergent, using a soft cloth. Rinse once more, then dry with a soft cloth or chamois. Exercise caution when using water inside enclosure. Make sure unit is completely dry inside before reassembling. (Do not use razor blades).

# Specifications

## Polycarbonate Enclosure

Flammability	Cover: UL94 V-2 Backbox: UL94 5VA
Wall Thickness	0.2 in (5.1mm)
NEMA Rating	4X, indoor and outdoor use
Warranty	Three year guarantee against breakage of polycarbonate in normal use (one year on electro mechanical and electronic components).

## Silicone Laminate Heater

STI-1229HTR, STI-1229HTR-WD 110 VAC 50/60 Hz	UL Recognized Component
STI-1229HTR240, STI-1229HTR240-WD 240 VAC 50/60 Hz	UL Recognized Component
	100 Watts
Life: @ -10°C (14°F) ~ 70°C (158°F)	5 Years
Duty Cycle: -40°F (-40°C)	53%
-70°F (-57°C)	71%

## Fan

24 VDC (±10%), 90 mA	UL Recognized Component
Life	5 Years Continuous Duty

**⚠ WARNING:** The polarity of the circulating fan is important as it only rotates in one direction with red lead being positive.

MISE EN GARDE : La polarité du ventilateur de circulation est importante car il ne tourne que dans un sens avec son fil rouge étant celui du pôle positif.

## Gasket

Material	Neoprene
Life	5 Years

## Installation Instructions

### Mount Backbox to Wall (Refer to Fig. 1)

1. Remove appliance heater assembly from back box and set aside.
2. Mount back box in desired location (wall mount only) using the four #10 x 1-1/2" screws and anchors (provided). Drill a 1/4" diameter pilot hole for plastic anchors at spacing in Fig. 1.

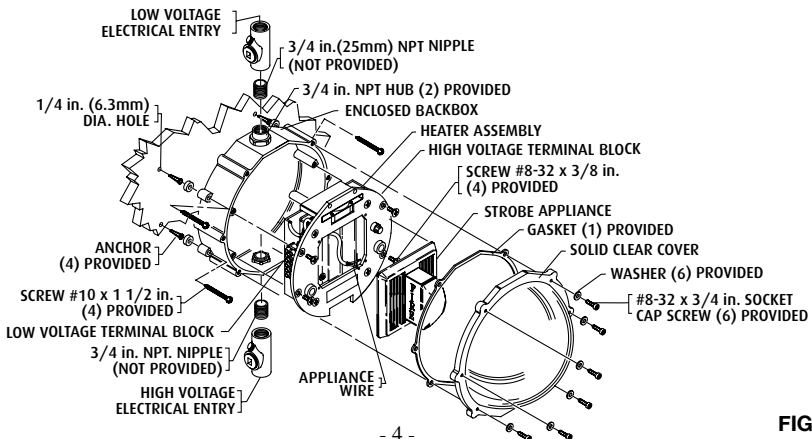

- Attach conduit hub to a 3/4" NPT nipple and conduit seal fitting to the back box, top and bottom.

**Note:** A conduit seal fitting must be used on both top and bottom conduit entries as close to the unit as possible. Use conduit seal Crouse-Hinds 3/4" EYSX 21 or equivalent. Conduit should be installed according to applicable NEC and local codes.

- Pull wiring into back box.

**Note:** High Voltage (110 or 240 VAC) wiring must enter thru bottom conduit and low voltage and signaling wires must enter thru top conduit and remain separated per NFPA 70, NEC, and local codes.

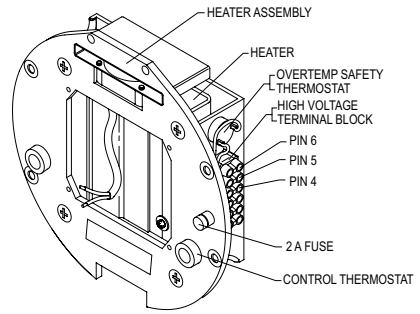

**FIGURE 2**

### HIGH VOLTAGE WIRING (Refer to Fig. 2)

- Connect high voltage: Make sure 110 or 240 VAC power is "OFF". Refer to high voltage schematic diagram on page 6.

	110 VAC	240 VAC
Pin 6	AC HOT	L-1
Pin 5	Neutral	L-2

### LOW VOLTAGE WIRING (Refer to Fig. 3 & Schematic drawings on Page 6)

- Connect Supervisory Module Connect EOL device (not included) between pins 1 and 2 of low voltage terminal block. Pins 1 and 2 should then be connected to the fire alarm supervisory control module.

**Note:** Fire alarm supervisory control module must be of the latching type only.



- Connect Fan Power

**Note:** Fan will not operate if polarity is reversed. Refer to low voltage schematic on page 6.

- Pin 3 -24 VDC
- Pin 4 +24 VDC

- Connect strobe appliance power from fire alarm panel.

- Pin 5 - 16-33 VDC
- Pin 6 +16-33 VDC

- Connect strobe out to next device (if needed)

- Pin 7 - 16-33 VDC
- Pin 8 +16-33 VDC

- Attach heater assembly to back box using (4) #8-32 x 3/8" flat head screws into heater assembly mounting bosses on back box (see Fig. 1). Make sure all service wiring is gathered away from the heater and be careful not to pinch wire under heater assembly. Fan must be mounted toward top of enclosure.

- Wire strobe in and out using Teflon coated wire provided. (White-Positive/Black-Negative) and attach to the strobe mounting bosses on heater assembly.

- Record installation date on label and in manual (page 2).

- Install cover and gasket with (6) #8-32 x 5/8" socket cap screws and (6) flat washers as shown in Fig. 4. Maximum torque 18-20 in./lb.

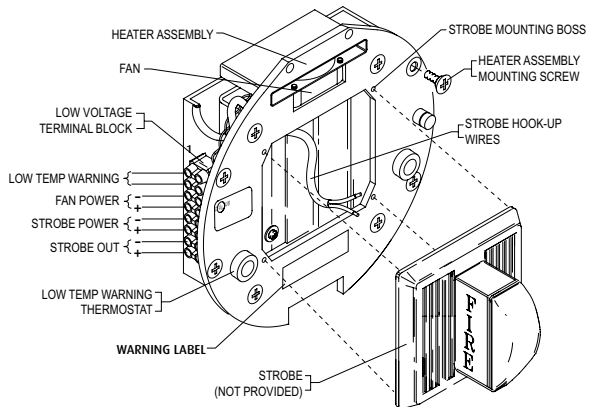

14. Turn all power to "ON" position.

**Note:** Fan runs continuously. This system requires three sources of power:

1. 110 or 240 VAC heater on the load side of the fuse holder.
2. 24 VDC power source for the circulating fan. Check fan to see if operating; if not check polarity and reverse then try again.
3. 6-33 VDC fire alarm notification circuit for strobes and temperature warning monitor.

## SCHEMATIC DIAGRAMS

### HIGH VOLTAGE CIRCUIT

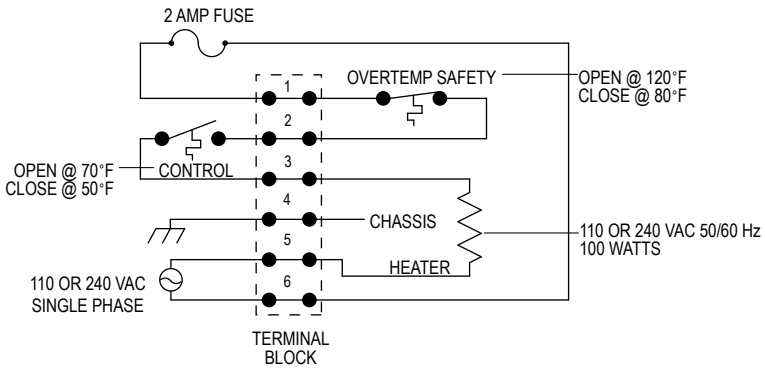

### LOW VOLTAGE CIRCUIT

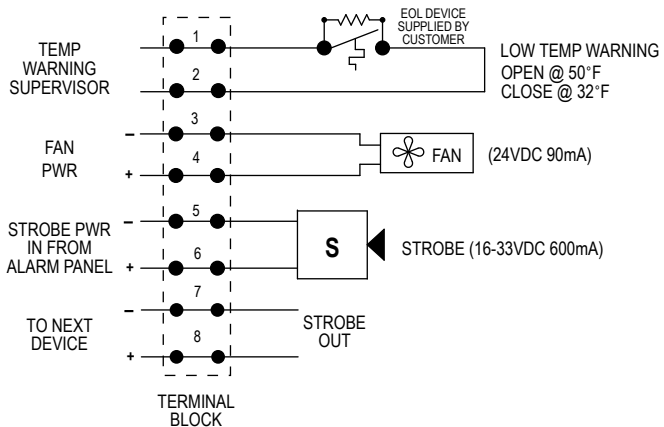

# PRODUCT ASSEMBLY

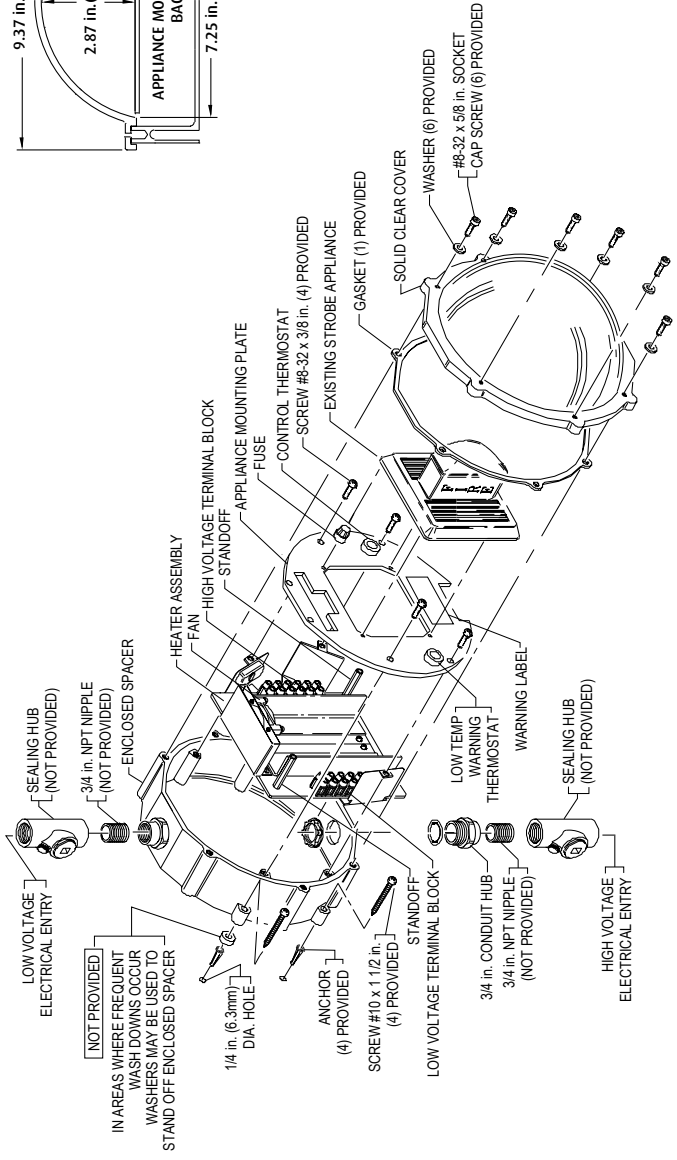
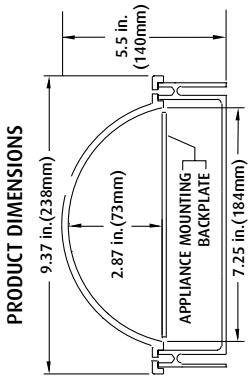

**FIGURE 4**

## Warranty

**⚠** WARNING: This product can expose you to chemicals including Dichloromethane, which is known to the State of California to cause cancer, and Bisphenol A (BPA), which is known to the State of California to cause birth defects or other reproductive harm.

For more information go to **[www.P65Warnings.ca.gov](http://www.P65Warnings.ca.gov)**.

Three year warranty or a one year limited warranty (from date of purchase) on most products. See website for details. Electronic warranty form at **[www.sti-usa.com/wc14](http://www.sti-usa.com/wc14)**.



USA



**Safety Technology  
International**

2306 Airport Rd • Waterford, MI 48327, USA  
Phone: 248-673-9898 • [info@sti-usa.com](mailto:info@sti-usa.com) • [www.sti-usa.com](http://www.sti-usa.com)

Taylor House • 34 Sherwood Road • Bromsgrove, Worcestershire • B60 3DR • England  
Tel: +44 (0)1527 520 999 • [info@sti-emea.com](mailto:info@sti-emea.com) • [www.sti-emea.com](http://www.sti-emea.com)

Unit 7A • Lockheed Avenue • Airport Business Park • Waterford • X91 HWF2 • Ireland  
[info@sti-emea.com](mailto:info@sti-emea.com) • [www.sti-emea.com](http://www.sti-emea.com)