

Alarmed Window Bar

WWW.GRISK.COM



Window Bar Series

- ◆ Fits windows 30" - 42"
- ◆ No cutting required
- ◆ Removes easily in emergency
- ◆ Reinforced extruded aluminum
- ◆ Protects 24 - 7

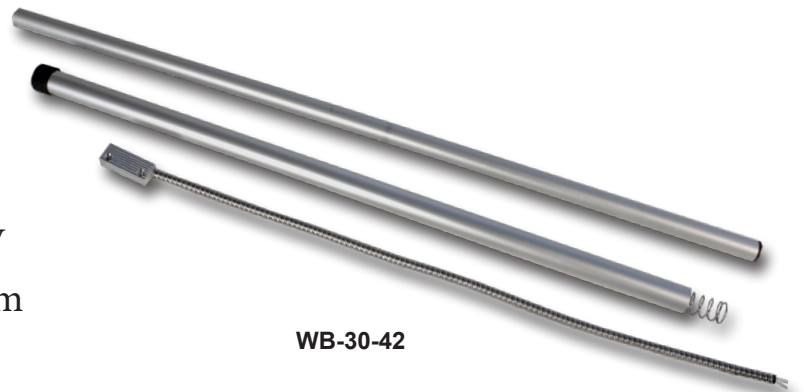

WB-30-42

GRI's Alarmed Window Bars will fit windows from 30" to 42" wide with no cutting required. If window is higher than 14", two or more Window Bars may be used. The GRI Window Bars protect both sides of a sliding window even when open without triggering an alarm and can be connected to a 24 hour zone. When the bar is dislodged an alarm is activated. The GRI Alarmed Window Bars are easy to removed during an emergency and will work with both hard wired or wireless systems. The bars are designed to fit the window one way and are difficult to be installed incorrectly. The reinforced extruded aluminum will not sag or flex in high temperatures.

The various ways in which the GRI Window Bar may be mounted are: on the window frame, inside the window frame and on most angled window frames.

Part Numbers

WB-30-42

WB-ASB (Angled Bracket Kit)

WARRANTY: One year warranty against workmanship, material and factory defects.

GEORGE RISK INDUSTRIES, INC.
G.R.I. PLAZA
KIMBALL, NE 69145

WWW.GRISK.COM



153

1-800-445-5218
1-800-523-1227
(308) 235-4645
FAX (308) 235-3561
E-MAIL: sales@grisk.com

Alarmed Window Bar

WWW.GRISK.COM



INSTALLATION INSTRUCTIONS FOR WB-30-42:

LIST OF COMPONENTS

1 - spring	1 - 20" round bar 3/4" diameter	1 - 8504 switch
2 - #4 x 1 screws	1 - 24" round bar 5/8" diameter	1 - M-5065 magnet (in 5/8" bar)
2 - #6 x 1" self-tap screws	2 - nylon clamps	1 - non-slip end cap

The GRI Window Bars should be installed no more than 6 inches apart and no more than 6 inches from the top and bottom of the window frame. On a 14" high window, the bar should be vertically centered.

Test switch before installing by using a continuity tester or a similar device. With the leads of the switch connected to the tester, place a magnet next to switch. The contacts of the switch will open and close as the magnet is moved within range of the switch. Mount Window Bar into selected area of window, making certain it is spaced correctly as noted above. Place small end of bar into recessed area of switch. Remove backing from double stick tape on switch and install on window frame or jamb. See diagram #1. Now that the Window Bar has been installed, test the switch again.

For angled window mounting, order WB-ASB bracket kit.

Note: Instructions should be given on removal of barrier bars to all residents of building where window bars are in use. The Window Bar is removed by grasping the ends of the bar and pushing them to the center and pulling the bar out of the window.

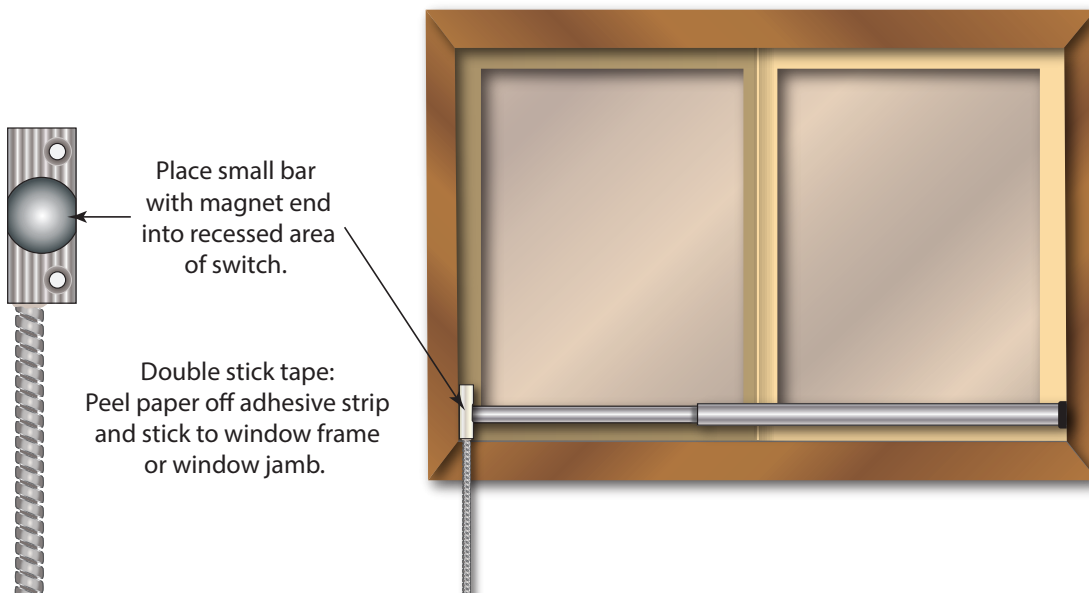

WARRANTY: One year warranty against workmanship, material and factory defects.

GEORGE RISK INDUSTRIES, INC.
G.R.I. PLAZA
KIMBALL, NE 69145

WWW.GRISK.COM



154

1-800-445-5218
1-800-523-1227
(308) 235-4645
FAX (308) 235-3561
E-MAIL: sales@grisk.com