

Add High Power Paging, Loud Ringing, and Background Music to SIP Based VoIP Phone Systems or Service Providers



The Viking model **PA-250-IP** SIP/Multicast Paging Amplifier provides up to 250 Watts of loud paging for SIP based VoIP phone systems (hardware or hosted/cloud based service provider). The **PA-250-IP** can be used for standard SIP endpoint paging or multicast paging.

The **PA-250-IP** can drive up to two hundred fifty (250) 70V speakers and/or paging horns (each speaker set to "1 Watt tap"). The small 1U rack size chassis is possible because the **PA-250-IP** uses new amplifier technology that is 3 times more efficient than old designs competitors use. The high efficiency of the **PA-250-IP** means much less heat dissipation, smaller size, higher reliability, and lower cost.

There are many advantages of using a 70V distributed audio paging system, such as being able to put more speakers on a wire run, having longer speaker wire runs, using smaller gauge wire, and being able to set the volume of each speaker independently.

***Note:** The **PA-250-IP** can not provide SIP voice paging and loud ringing at the same time but it can be configured to SIP voice page during the day and loud ring at night.

The **PA-250-IP** features individual level controls with LED indicators for each input, automatic peak limiting, multiple amplifier protection modes, an adjustable Automatic Level Control, and Bass & Treble Controls.

The unit easily connects with a single CAT5/6 cable from your network switch. The night ring feature is programmable for time of day and day of week to enable loud ringing for after hour incoming calls.*

A 600 Ohm output to allow more paging amplification to be added if needed. The **PA-250-IP** has inputs for Background Music and Aux Input. The Aux Input allows the addition of another audio source such as a clock-controlled tone generator (Viking model **CTG-1A** or **CTG-2A**), or emergency notification system (Viking model **DNA-510**).

⚠ Installation requires a Network Administrator / IT Technician

Features

- SIP compliant (see page 2 for more information)
- SIP endpoint or multicast group member
- SIP/Multicast: SIP page, SIP page and zoned multicast receive
- Plays audio from standard multicast sources
- Compatible with Polycom multicast paging
- Red "Page/Status" LED indicator
- Network downloadable firmware
- Support for access code to prevent unwanted SIP calls
- Network remote volume control
- Paging prioritization
- Programmable pre-page alert tone
- Powerful 70V amplifier drives up to 250 Watt load
- Door chime trigger input
- Auxiliary and background music inputs
- Individual and master volume controls
- Bass and treble controls
- LEDs show audio level and activity
- Provides loud ringing
- 600 Ohm output to drive additional amplifiers
- Adjustable Automatic Level Control
- Peak limiter and multiple protection modes
- Tamper resistant trim pots

Information: 715-386-8861
www.VikingElectronics.com

Applications

- Amplified SIP endpoint or multicast IP paging for: schools, hospitals, retail stores, office spaces, etc.
- Provide multicast background music and sound masking
- Paging systems requiring up to 250 speakers
- Installations that can utilize the below advantages of a 70V distributed audio system:
 - Longer wire runs using smaller gauge speaker wire to save costs
 - Many speakers can be connected on the same wire run to save costs
 - Set each speaker's volume individually using its own power taps

Specifications

Power: 100V to 240V AC 50 to 60Hz (No PoE power required)
Dimensions: approx. 19" x 1.75" x 6" (483 mm x 44.5 mm x 153 mm)
Shipping Weight: 5.3 lbs (2.4 kg)
Environmental: 0°C to 32°C (32°F to 90°F) with 5% to 95% non-condensing humidity
SIP Audio Codecs: G711u, G722 and G711a
Multicast Audio Codecs: G711u and G722
Network Compliance: IEEE 802.3 af, SIP 2.0 RFC3261, 100BASE-TX with auto cross over
Regulatory Compliance: CE, FCC Part 15 and Canada ICES-003 Class A
Frequency Response: 55 – 18,000 Hz (+/- 10 dB)
Connections: (1) RJ45 10/100 Base-T, (1) 3.5mm, (2) IEC C8 AC power inlets, (11) removable cage clamp screw terminals
Power Cord: Dual IEC C7 plugs "Y" power cord included

VoIP SIP System Compatibility

For compatibility and vendor specific detailed configuration instructions, see the **Viking VoIP SIP System Compatibility List**, DOD 944. To open and download this PDF file:

Scan the QR code below to open and download the **Viking VoIP SIP System Compatibility List**



- OR -

1. Go to **www.vikingelectronics.com** and enter **944** in the search box
2. Click **Application Note (DOD 944)** to open and download the PDF

Important: Exclusion from this list means only that compatibility has not been verified, ***it does not mean incompatibility.*** If you have questions, please call Viking Electronics at 715-386-8861.

Definitions

Client: A computer or device that makes use of a server. As an example, the client might request a particular file from the server.

DHCP: Dynamic Host Configuration Protocol. In this procedure the network server or router takes note of a client's MAC address and assigns an IP address to allow the client to communicate with other devices on the network.

DNS Server: A DNS (Domain Name System) server translates domain names (ie: www.vikingelectronics.com) into an IP address.

Ethernet: Ethernet is the most commonly used LAN technology. An Ethernet Local Area Network typically uses twisted pair wires to achieve transmission speeds up to 1Gbps.

Host: A computer or device connected to a network.

Host Name: A host name is a label assigned to a device connected to a computer network that is used to identify the device in various forms of network communication.

Hosts File: A file stored in a computer that lists host names and their corresponding IP addresses with the purpose of mapping addresses to hosts or vice versa.

Internet: A worldwide system of computer networks running on IP protocol which can be accessed by individual computers or networks.

IP: Internet Protocol is the set of communications conventions that govern the way computers communicate on networks and on the Internet.

IP Address: This is the address that uniquely identifies a host on a network.

LAN: Local Area Network. A LAN is a network connecting computers and other devices within an office or building.

Lease: The amount of time a DHCP server reserves an address it has assigned. If the address isn't used by the host for a period of time, the lease can expire and the address can be assigned to another host.

MAC Address: MAC stands for Media Access Control. A MAC address, also called a hardware address or physical address, is a unique address assigned to a device at the factory. It resides in the device's memory and is used by network equipment to send data packets to the correct IP address. You can find the MAC address of your **PA-250-IP** page adapter printed on a white label on the bottom side of the chassis.

Router: A device that forwards data from one network to another. In order to send information to the right location, routers look at IP Address, MAC Address and Subnet Mask.

RTP: Real-Time Transport Protocol is an Internet protocol standard that specifies a way for programs to manage the real-time transmission of multimedia data over either unicast or multicast network services.

Server: A computer or device that fulfills requests from a client. This could involve the server sending a particular file requested by the client.

Session Initiation Protocol (SIP): Is a signaling communications protocol, widely used for controlling multimedia communication sessions such as voice and video calls over Internet Protocol (IP) networks. The protocol defines the messages that are sent between endpoints, which govern establishment, termination and other essential elements of a call.

Static IP Address: A static IP Address has been assigned manually and is permanent until it is manually removed. It is not subject to the Lease limitations of a Dynamic IP Address assigned by the DHCP Server. The default static IP Address is: **192.168.154.1**

Subnet: A portion of a network that shares a common address component. On TCP/IP networks, subnets are defined as all devices whose IP addresses have the same prefix. For example, all devices with IP addresses that start with 100.100.100. would be part of the same subnet. Dividing a network into subnets is useful for both security and performance reasons. IP networks are divided using a subnet mask.

TCP/IP: Transmission Control Protocol/Internet Protocol is the suite of communications protocols used to connect hosts on the Internet. TCP/IP uses several protocols, the two main ones being TCP and IP. TCP/IP is built into the UNIX operating system and is used by the Internet, making it the de facto standard for transmitting data over networks.

TISP: Telephone Internet Service Provider

WAN: Wide Area Network. A WAN is a network comprising a large geographical area like a state or country. The largest WAN is the Internet.

Wireless Access Point (AP): A device that allows wireless devices to connect to a wired network using Wi-Fi, or related standards. The AP usually connects to a router (via a wired network) as a standalone device, but it can also be an integral component of the router itself.

Wireless Repeater (Wireless Range Extender): takes an existing signal from a wireless router or access point and rebroadcasts it to create a second network. When two or more hosts have to be connected with one another over the IEEE 802.11 protocol and the distance is too long for a direct connection to be established, a wireless repeater is used to bridge the gap.

Features Overview

⚠ IMPORTANT: Electronic devices are susceptible to lightning and power station electrical surges from the AC outlet. It is recommended that a surge protector be installed to protect against such surges.

PA-250-IP Front View



- ALC:** Automatic Level Control adjustment for SIP Page and Multicast
- PAGE:** SIP Page and Multicast volume control and LED showing activity and audio level
- AUX:** Auxiliary Input volume control and LED showing activity and audio level
- CHIME:** Volume control and LED indicator for Chime tones
- MUSIC:** Volume control for Background Music Input
- BASS:** Low frequency tone control
- TREBLE:** High frequency tone control
- MASTER VOLUME:** Master volume control and LED level indicator for setting Peak Limiting
- POWER:** LED indicating power is on (winks off to indicate an overload condition)



Use included slotted bit to adjust tamper resistant front panel pots.

PA-250-IP Back View

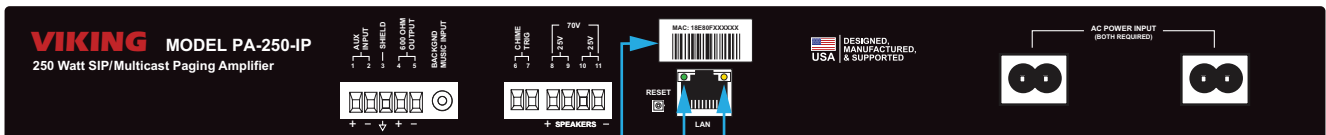

AUX INPUT:
Auxiliary analog input

SHIELD:
Analog ground

600 OHM OUTPUT:
Output for driving additional amplifiers

BACKGROUND MUSIC INPUT:
3.5mm jack for connecting music source

CHIME TRIG:
To trigger doorbell chime tones

SPEAKERS: Connect up to two hundred fifty (250) 70V or 25V speakers and/or paging horns

AC POWER INPUT:
Connect to 100V to 240V AC power using the included "Y" power cord

Yellow Network Status LED: Lights steady to indicate power and data link. Blinks to indicate network activity.

LAN Port 10/100: Connect to your LAN via RJ45 plug and CAT5 or greater twisted pair wire.

Green Unit Status LED

Reset Button

MAC Address Label: The MAC address is a unique 12 digit number used by network equipment to send data packets to the correct IP address.

Installation

A. Auxiliary Input

Step 1	Connect any line level source to the AUX IN terminals (pins 1 & 2).
Step 2	Adjust the front panel AUX trim pot so the AUX LED flashes with Aux audio.
Step 3	If the auxiliary audio is coming from an RCA jack, and hum or buzz is present in the audio, the RCA cable's shield may need to be grounded on the PA-250-IP side. This can be done by connecting the cable's shield to the SHIELD terminal (pin 3).

NOTE: A speaker level signal can be connected to the **AUX IN** terminals, as long as the front panel **AUX** trim pot is turned down low enough to not overdrive the input.

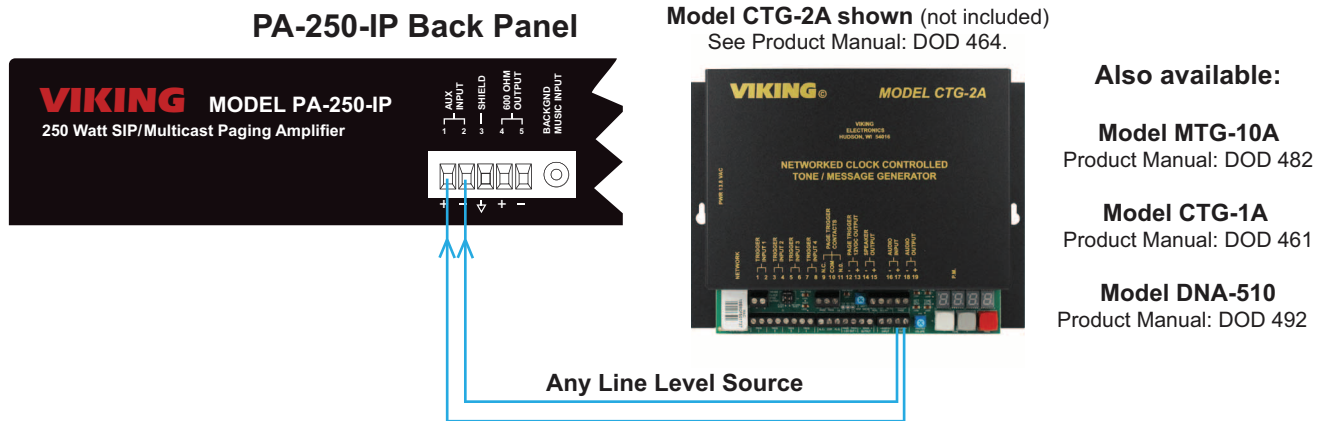

B. 600 Ohm Output for Additional Paging Power

When more than a 250 Watt load is required, a Viking model **PP-250** can be added to achieve a 500 Watt load capability.

Step 1	Connect the PA-250-IP 600 OHM OUTPUT terminals (pins 4 & 5), to the PP-250 terminals (pins 1 & 2).
Step 2	If a shield cable is used, connect the cable shield at both ends.
Step 3	Adjust the PP-250-IP's front panel INPUT trim pot so the LED flashes with page audio.

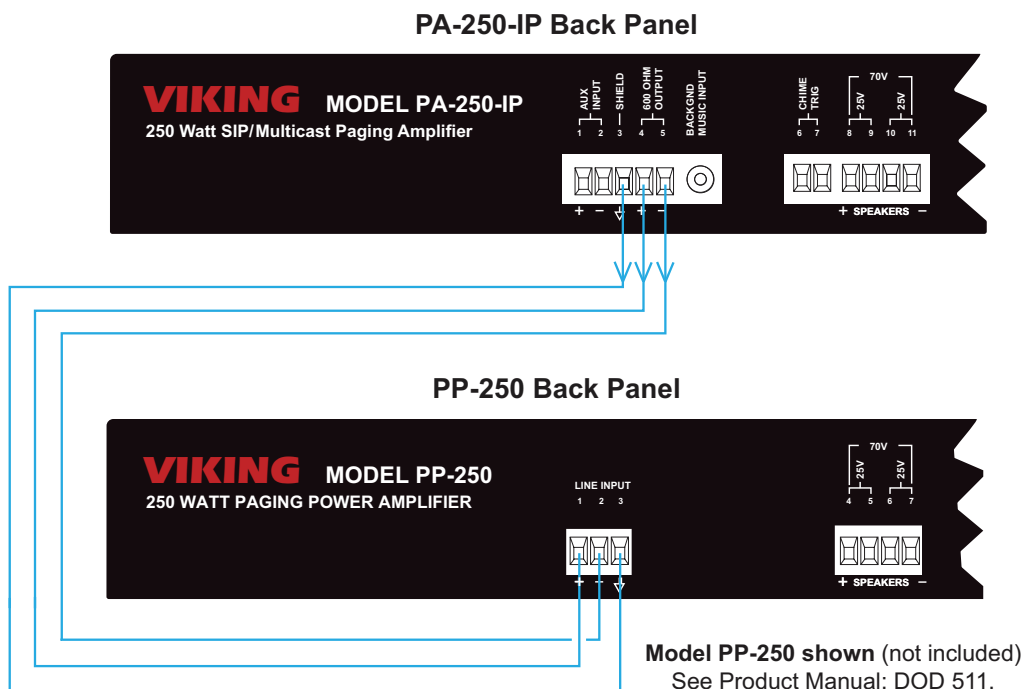

C. Background Music Input

Step 1	Connect a background music source to the BACKGROUND MUSIC INPUT jack using a 1/8" (3.5mm) cable.
Step 2	Adjust the front panel music trim pot to the desired level.

NOTE: Background music will play only when all other inputs are idle.

PA-250-IP Back Panel

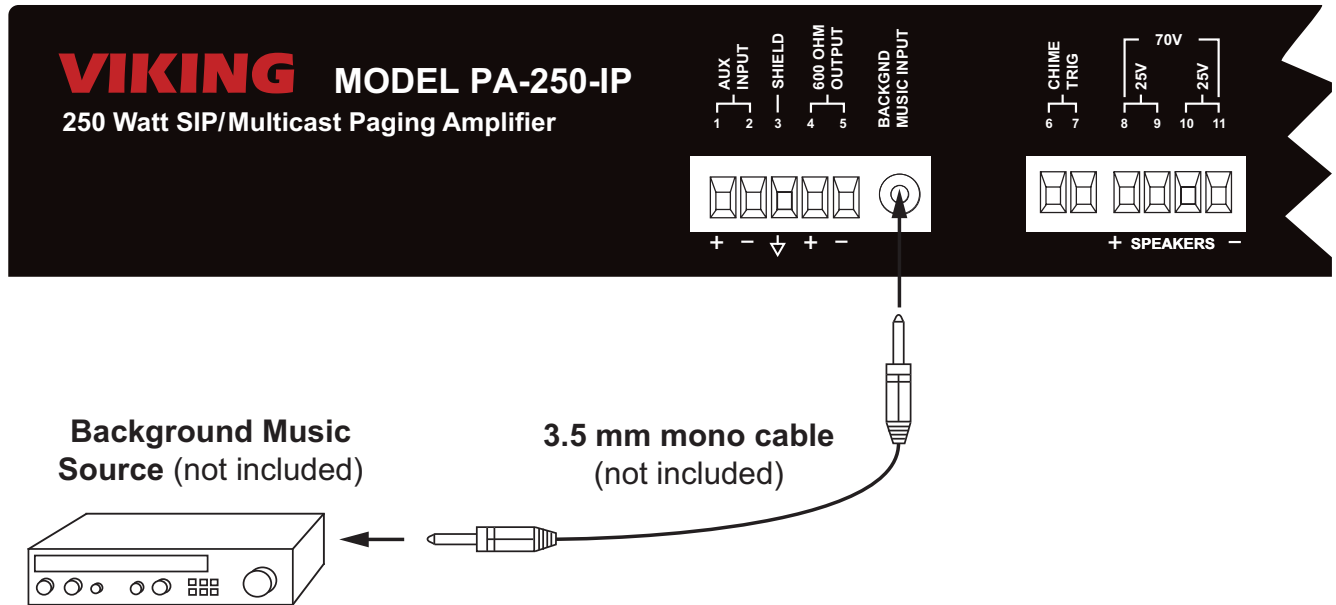

D. Chime Trigger

Step 1	Connect any momentary contact closure (such as a non-lighted door bell button) to the CHIME TRIG terminals (pins 6 & 7).
Step 2	A momentary closure will trigger a "Door Chime" (ding dong) tone.
Step 3	The front panel CHIME trim pot can be used to adjust chime tone volume.

PA-250-IP Back Panel

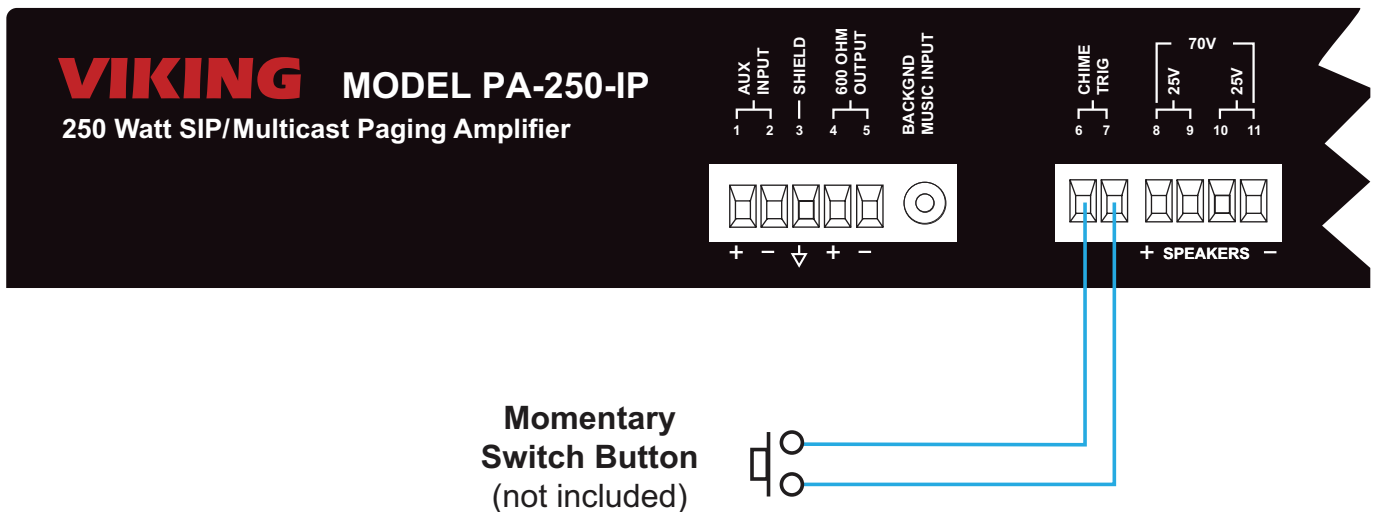

E. Speakers

Step 1	Connect 70V speakers across the 70V SPEAKERS terminals (pins 8 & 11).
Step 2	If using 25V speakers, connect half of them across the 25V SPEAKERS terminals (pins 8 & 9), and the other half across the 25V SPEAKERS terminals (pins 10 & 11), so that the power load is balanced between the two outputs.
Step 3	Check the power tap of each speaker connected, and be sure the sum of all the speakers connected does not exceed 250 Watts. For example, if there are 40 speakers, and all are wired to their 5 Watt taps, the amplifier is driving a 200 Watt load. Since the PA-250-IP is capable of driving a 250 Watt load, additional speakers could be added, or some of the existing speakers could be tapped at a higher wattage setting to play louder. If the total speaker load goes “over budget” (greater than 250 Watt load), either remove some speakers, or use lower power taps to get down to a 250 Watt load. If more than 250 Watt load is needed, a PP-250 can be added as shown in Installation section B .

PA-250-IP Back Panel

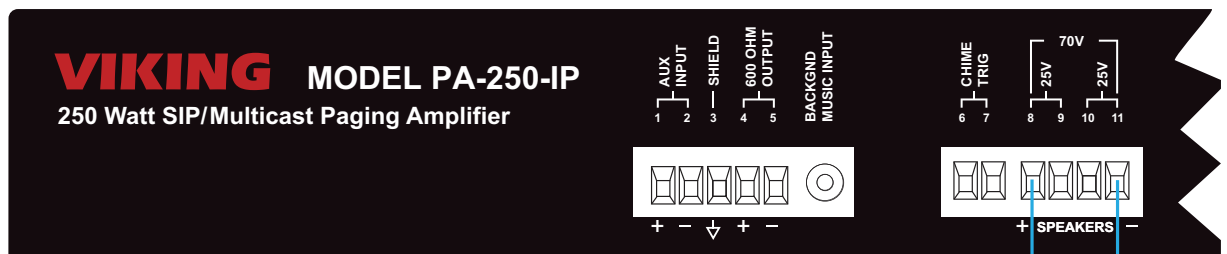

70V Paging Speakers

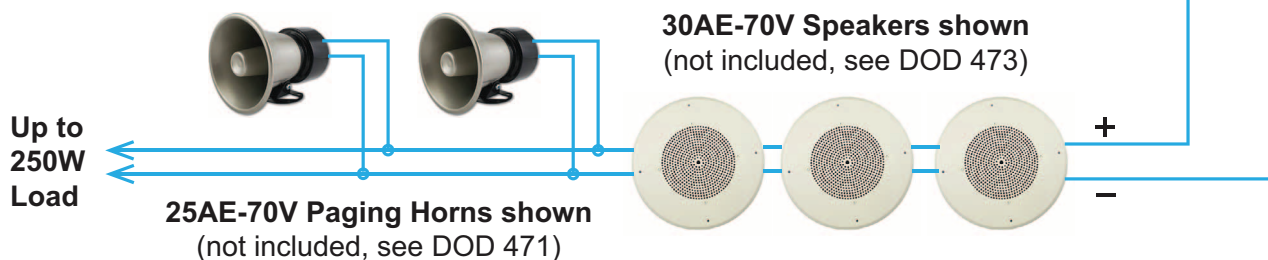

NOTE: For wire run lengths up to 500 feet, use #18 gauge or larger speaker cables. For wire run lengths up to 1000 feet, use #16 gauge or larger speaker cables. For wire run lengths up to 1500 feet, use #14 gauge or larger speaker cables, etc.

F. AC Power Input

Step 1	Connect both IEC C7 plugs from the supplied “Y” AC power cord into the two AC POWER INPUTS on the back of the PA-250-IP .
Step 2	Once all other connections are made, power up the PA-250-IP by plugging the AC power plug end of the supplied “Y” AC power cord into a power outlet.

PA-250-IP Back Panel

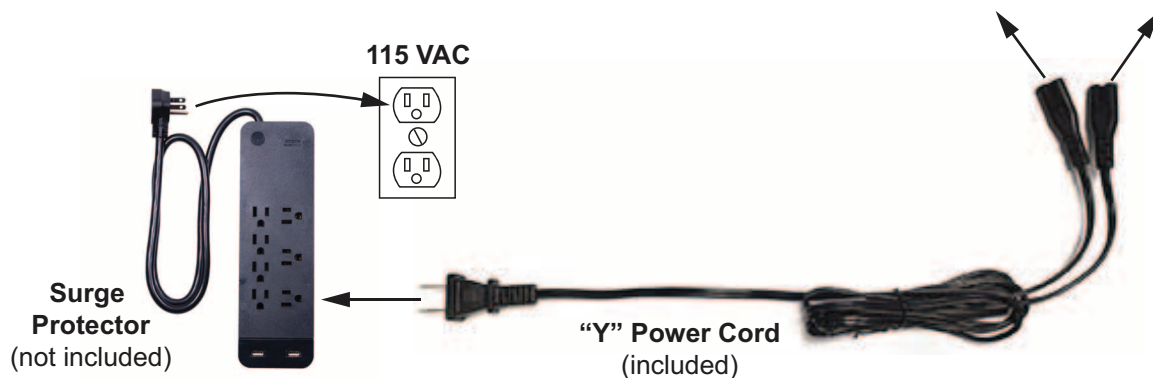
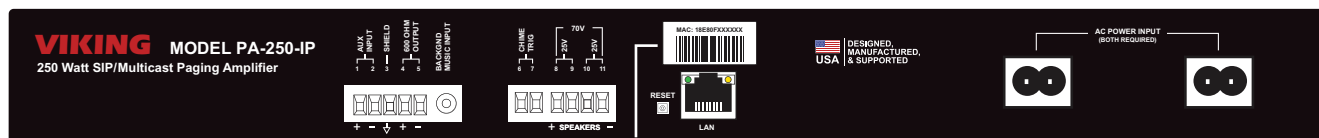

⚠ IMPORTANT: Electronic devices are susceptible to lightning and power station electrical surges from the AC outlet . It is recommended that a surge protector be installed to protect against such surges.

Typical Installation on SIP Based VoIP Phone System

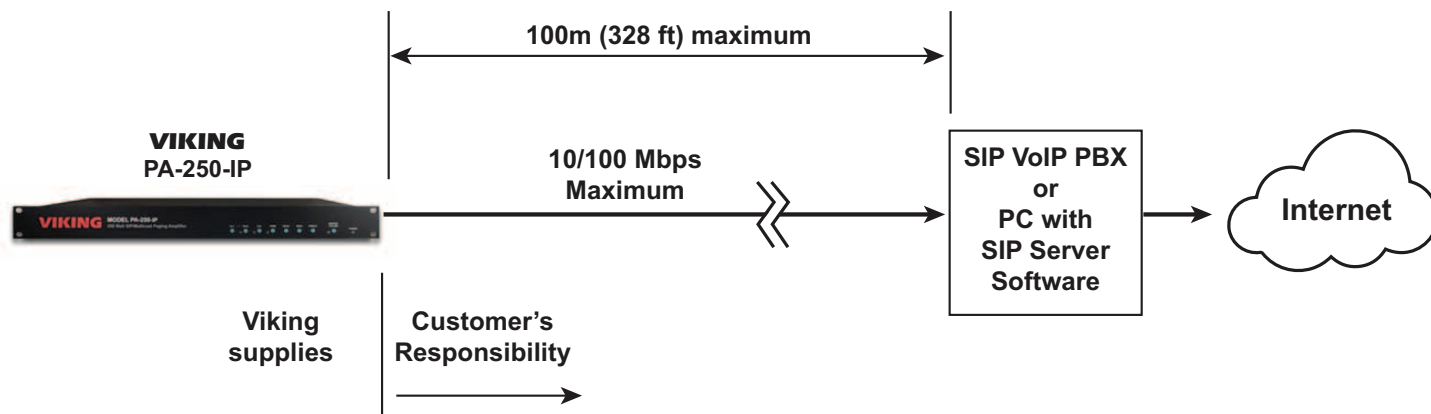

PC Requirements

- IBM compatible personal computer with: Windows 7, 8 or 10
- Adobe Acrobat Reader 8 or higher
- PA-250-IP hardware
- Available LAN
- Ethernet cable (CAT5 minimum)
- 1 MB minimum free hard drive space for installation
- 16MB of free physical RAM

PC Programming

Download and install the programming software

1. Go to www.vikingelectronics.com and enter **PA-250-IP** in the search box
2. Click **PA-250-IP** in the search results
3. Scroll down the page to Downloads, click **IP Programming Software**
4. Install the programming software by saving or opening the file and then clicking on **setup Viking IP Programming.exe**
5. Follow the prompts on your screen to complete software installation
6. To start the Viking IP Programming application, click on the Viking IP Programming icon on your desk top. The Main screen will appear, allowing the user to program any **PA-250-IP** connected to that LAN.

NOTE: PC must be connected to the same LAN as the **PA-250-IP**.

A. Connect/Disconnect

Open the “Viking IP Programming” software on the PC and the start screen shown below will appear. Any Viking IP products that are connected to the network will appear on the list. Simply select the **PA-250-IP** on the list and click on the “Connect” button at the bottom or double click the selected unit. If no username and password have been programmed and the security code of the selected unit is still set to default (845464), the PC software will not require entering a username, password or security code to connect to the **PA-250-IP**. If the **PA-250-IP** has been programmed with a username and password, a pop up window will ask for the username followed by the password. If the unit’s security code has been changed from “845464”, it will then prompt for the correct security code. **PA-250-IP**’s have a default name of “VIKING_KM64_Vik02”, so if many **PA-250-IP**’s are connected to the same network and all have the default name, MAC addresses must be used to identify each **PA-250-IP**. When finished programming, click on the “Disconnect” button at the bottom. Closing the program will also automatically disconnect the unit.

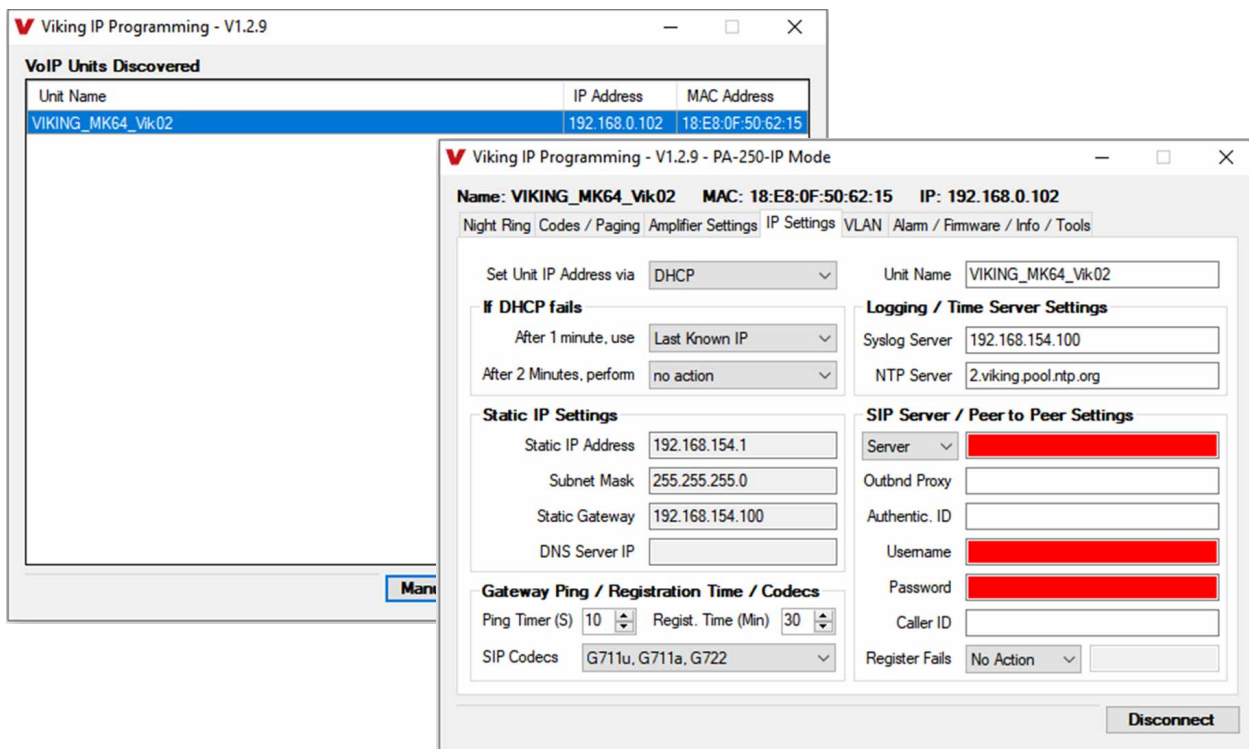

B. Configuring the PA-250-IP Network Settings

Step 1	Open the “Viking IP Programming” software on a windows PC that is connected to the same LAN as the PA-250-IP amplifier to be programmed.
Step 2	The window in the upper left corner of the menu will show you each PA-250-IP that is connected to that LAN. Select the unit with the same MAC address shown on the label located on the top of the Ethernet connector on the PA-250-IP or the matching label that can be found on the back panel.
Step 3	Click on the “connect” button. A default PA-250-IP has no username or password programmed, the security code is set to “845464” and when configured this way, you are instantly connected to the PA-250-IP . If the PA-250-IP has been programmed with a username and password, a pop up window will ask for the username followed by the password. If the unit’s security code has been changed from “845464”, it will then prompt for the correct security code, then click “retry”.
Step 4	The program will then read and display the PA-250-IP ’s IP and programming settings.
Step 5	Click on the “IP Settings” tab.
Step 6	Select the appropriate value Static IP Settings or DHCP for “Set Unit IP Address via”. NOTE: Changing the IP address will cause you to have to reconnect to the unit. Enter the values for the fields in “if DHCP fails” or “Static IP Settings” as needed.
Step 7	Set the “Unit Name”, “Logging / Time Server Settings” as needed.
Step 8	Select Peer-Peer in the “SIP Server / Peer to Peer Settings” to use the unit in Peer to Peer mode or for Multicast paging only. Select Server to register with a SIP registrar server and fill in the “Outbnd Proxy” (SIP Outbound Proxy Server Address, “ip:port”), “Authentic. ID” (SIP Authentication ID), “Username” (SIP Username, <string>), “Password” (SIP Password), and “Caller ID” (SIP Caller ID) with values from your VoIP provider. Required fields will be red when the unit is not registered.

C. Configuring PA-250-IP VLAN Settings

Step 1	Click on the "VLAN" tab.
Step 2	Disable or enable VLAN tagging by setting the value of "VLAN Tagging".
Step 3	Set the VLAN tag ID by selecting an integer (1 to 4094) in "ID for all packets".
Step 4	Set the Priority Code Point (PCP) value for all not SIP and RTP packets in the "PCP for all packets" input (0 is default, priorities are from low to high: 0, 1, 2, 3, 4, 5, 6, 7). Set the "PCP for SIP packets" (3 is default). Set the "PCP for RTP packets" (5 is default).

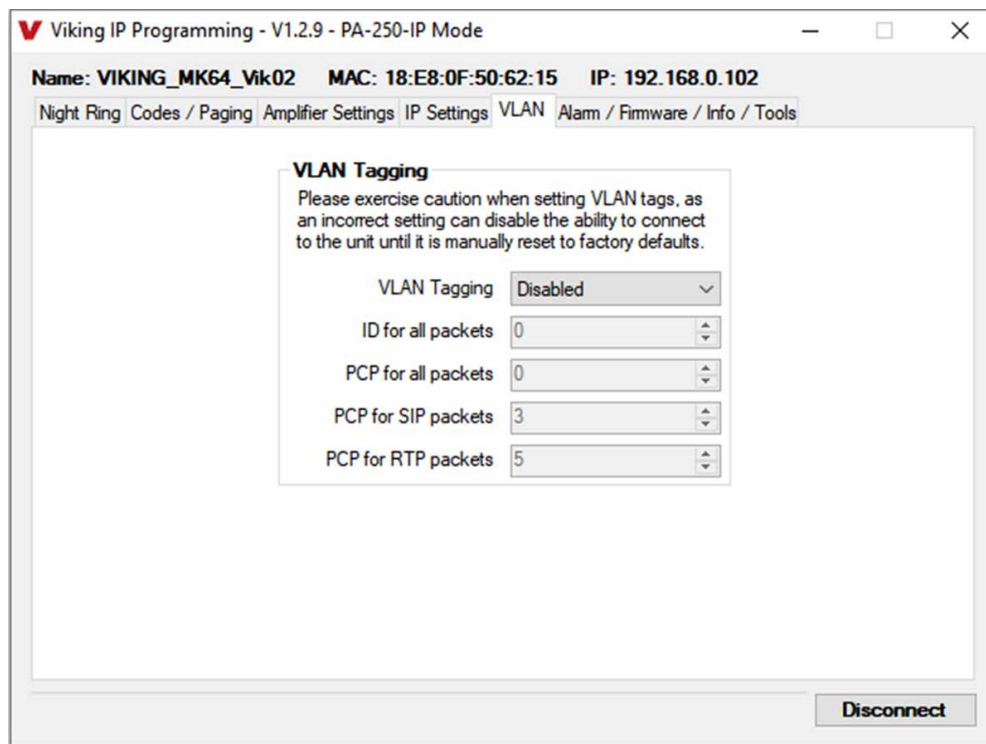

D. Manually Resetting the Security Code to Enter Programming

NOTE: This procedure will not erase a username and password used to access the **PA-250-IP** program mode. Only the security code is set to default.

Step 1	Power down the PA-250-IP by disconnecting the power cord.
Step 2	Press and hold the Reset button, then reconnect the power cord.
Step 3	Continue to hold the Reset button and watch the RED Status LED (illuminating the Reset button). The Status LED will start to flash, then switches to a faster rate of flash (approximately 8 seconds after power up). Release the Reset button.
Step 4	The security code is now reset to 845464 (factory default).
Step 5	You can now enter programming by following the steps in section A .

E. Manually Resetting All Network Parameters to Factory Default

NOTE: This procedure will erase a username and password that are used to access the **PA-250-IP** program mode.

Step 1	Power down the PA-250-IP by disconnecting the power cord.
Step 2	Press and hold the Reset button, then reconnect the power cord.
Step 3	Continue to hold the Reset button and watch the RED Status LED (illuminating the Reset button). The Status LED will start to flash, then switches to a faster rate of flash, then goes off briefly and comes back on steady (approximately 16 seconds after power up). Release the Reset button.
Step 4	You can now enter programming by following the steps in section A .

Programming Features Index

DESCRIPTION	Section	Page
Connect/Disconnect	A	10
VLAN Settings	C	11
Unit Name	1	13
SIP Server	2	13
Peer to Peer Settings	3	13
Outbound Proxy	4	13
Authentication ID	5	13
Register Fails (Re-Resolve or Alternate Server)	6	13
Security code (factory set to 845464)	7	14
Access Code (1 - 6 digits, blank = disabled, factory set to 123456)	8	14
Multicast Page Type (factory set to Standard)	9	14
SIP Page Priority over Multicast Page	10	15
Multicast Paging	11	15
Multicast Paging Volume (0 - 19, factory set to 1)	12	15
SIP Paging Volume (0 - 19, factory set to 1)	13	16
Ring Volume (0 - 19, factory set to 5)	14	16
SIP Page Length Time Out (disabled or 1 - 9 minutes, factory set to 3 minutes)	15	16
Multicast Page Length Time Out (1 to 255 seconds or Disabled, factory set to 180 seconds)	16	16
Inbound Call Mode (Disabled, Auto Answer, Auto Answer-Secure or Ring, factory set to Auto Answer)	17	17
Ring Cadence (factory set to Normal, 2 seconds ON 4 seconds OFF)	18	17
LED Mode (OFF, ON or Paging, factory set to Paging)	19	17
DTMF Regeneration	20	17
Pre Page Tone	21	17
Mute Current / Next Alarm	22	18
Permanent Alarm Mute	23	18
Programming User name and Password	24	18
IP Firmware	25	18
Unit Firmware	26	18
Import/Export	27	19
Clear Amplifier Settings	28	19
Clear IP Settings	29	19
Night Ring Timed Operation	30	19
Time Zone Settings/daylight Saving Time	31	19

Programming Features

1. Unit Name

Up to a 31 character unit name can be assigned to the **PA-250-IP** being programmed.

2. SIP Server

Enter the IP address or URL of your SIP server or service provider in this field. The SIP server IP address is limited to 74 characters. **NOTE:** If an alternate SIP server IP address is programmed, the IP address for the SIP server and alternate SIP server will be limited to 31 characters.

3. Peer to Peer Settings

When set to Peer to Peer mode a SIP server is not used. The unit should be programmed with a Static IP Address and Username, a password is not used. Caller ID can be programmed if needed. Simply call the unit by entering the programmed "username@192.168...(Static IP address for the unit)". The static IP address is normally programmed into a page button on the VoIP telephones. **NOTE:** Peer to Peer mode does not affect Multicast paging.

4. Outbound Proxy

If your SIP provider requires an outbound proxy IP address enter it in the "Outbnd Proxy" field. **NOTE:** If Outbound Proxy is not required, leave this field blank.

5. Authentication ID

If your SIP provider requires Authentication ID, enter it in the Authentic. ID field. If Authentication ID is not required, leave this field blank.

6. Register Fails (Re-Resolve or Alternate Server)

When registered to a SIP server in the event that registration is lost you can program the unit to re-resolve using the current SIP server IP address or route pages through an alternate SIP server. With Alternate Server selected enter the IP address of the alternate SIP server in the field next to the Register Fails drop down box. **NOTE:** With an alternate SIP server IP address programmed, the IP address for the SIP server and alternate SIP server will be limited to 31 characters.

The screenshot shows the 'Viking IP Programming - V1.2.9 - PA-250-IP Mode' window. At the top, it displays the unit's Name: VIKING_MK64_Vik02, MAC: 18:E8:0F:50:62:15, and IP: 192.168.0.102. Below this are several tabs: Night Ring, Codes / Paging, Amplifier Settings, IP Settings, VLAN, Alarm / Firmware / Info / Tools. The 'Codes / Paging' tab is active, showing two sections: 'Security and Access Codes' and 'SIP Page Priority over Multicast Page'. The 'Security and Access Codes' section has input fields for 'Security Code (6 digits)' with value 845464 and 'Access Code (0-6 digits)' with value 123456. The 'SIP Page Priority over Multicast Page' section has a dropdown for 'SIP page priority level' set to 'Above Group 0 (Highest)' and a note '(Group 0 is highest priority, group 9 is lowest)'. Below these is a table for 'Paging Sources (Multicast IP and Port) - Volume Level - Timeout Enable/Disable' with 10 rows (0-9). Each row has input fields for IP, port, volume level, and a 'TO' checkbox. A 'Disconnect' button is at the bottom right.

Source	IP	Port	Vol	TO
0		1	1	<input checked="" type="checkbox"/>
1		1	1	<input checked="" type="checkbox"/>
2		1	1	<input checked="" type="checkbox"/>
3		1	1	<input checked="" type="checkbox"/>
4		1	1	<input checked="" type="checkbox"/>
5		1	1	<input checked="" type="checkbox"/>
6		1	1	<input checked="" type="checkbox"/>
7		1	1	<input checked="" type="checkbox"/>
8		1	1	<input checked="" type="checkbox"/>
9		1	1	<input type="checkbox"/>

7. Security Code

The security code allows the user/installer to program the **PA-250-IP** with a PC and the required ‘Viking IP Programming’ software. If the security code is left as default, the PC software won’t require entering a security code when connecting to the **PA-250-IP**. It is recommended that the factory set security code be changed. The security code can be set back to default by holding the Reset button while the **PA-250-IP** powers up. See section D on page 7 for details. It can also be defaulted by connecting to the unit with the IP Programming Software and clicking on the ‘Clear Adapter Settings’ button on the ‘Alarm / Firmware’ tab. **Factory Setting:** 845464

NOTE: The security code must be 6 digits and cannot include a * or #.

8. Access Code

The Access Code is used with the ‘Auto Answer Secure’ Inbound Call Mode to force inbound SIP page callers to dial the Access Code before they can make a SIP page. When you call the **PA-250-IP** and the unit automatically answers the call (see Programming section 18), you must dial the Access Code before you make a SIP page. Once a tenant has entered the correct Access Code, 2 beeps are heard and the user can now page (see Operation section C). The Access Code can be disabled if this basic security is not required. **Factory Setting:** 123456

NOTE: The Access Code can be 1 - 6 digits in length and cannot include a * or # or match the numbers used for the Security Code.

9. Multicast Page Type

Multicast Page Type needs to be selected under the Amp Settings tab (see picture on page 16). Select Standard or Polycom as the source of multicast paging. If Polycom is selected as the source, the Codes / Paging screen will change to show its options (shown below). **Factory Setting:** Standard (shown on page 13)

The screenshot shows the 'Viking IP Programming - V1.2.9 - PA-250-IP Mode' window. At the top, it displays the device name 'VIKING_MK64_Vik02', MAC address '18:E8:0F:50:62:15', and IP address '192.168.0.102'. The 'Codes / Paging' tab is selected, showing two main sections: 'Security and Access Codes' and 'SIP Page Priority over Multicast Page'. In the 'Security and Access Codes' section, the 'Security Code (6 digits)' is set to '845464' and the 'Access Code (0-6 digits)' is set to '123456'. The 'SIP Page Priority over Multicast Page' section has a dropdown menu for 'SIP page priority level' set to 'Polycom'. Below these sections is the 'Polycom Paging Source and Group Subscriptions' section, which includes fields for 'IP Address' (224.0.1.116), 'Port' (5001), 'Volume' (1), and a checked 'Timeout' box. A note states 'Select which Polycom groups to subscribe to, group 25 (Emergency) is always enabled'. A grid of checkboxes for groups Grp 01 through Grp 24 is shown, with all checkboxes checked. At the bottom right, there are 'Apply' and 'Disconnect' buttons.

10. SIP Page Priority over Multicast Page

Incoming **PA-250-IP** SIP call audio streams can be programmed to have priority over any of the 10 standard Multicast paging groups. Simply Use the “Sip Page Priority Level” drop down menu to select which Multicast group you want SIP calls to have priority over. **Factory Setting:** 0 (SIP is highest priority)

When Polycom is selected as the Multicast Page Type, the “SIP Page Priority Level” can be set to “Polycom” or “None”. See the following tables for the order of priorities with each setting. As shown, Polycom Group 25 multicast is the highest priority. The priority options allow you to determine the priorities for Polycom Groups 1 through 24 multicast signals and SIP paging. **Factory Setting:** Polycom

Paging Priorities (SIP Page Priority Level set to “Polycom”)	Paging Priorities (SIP Page Priority Level set to “None”)
Polycom Group 25	Polycom Group 25
SIP paging	Polycom Groups 1-24
Polycom Groups 1-24	SIP paging

11. Multicast Paging

Standard

When using standard Multicast Paging, up to 10 multicast paging groups can be programmed into each **PA-250-IP** paging amplifier. Each multicast group is defined by a multicast address and port number. Each multicast group is assigned a priority, allowing simultaneously arriving pages to be serviced based on importance. A timeout check box can be selected for each paging group. See Multicast Page Length Time Out under Speaker Settings to adjust the timeout from 1 to 255 seconds. Only one timeout time can be programmed for all Multicast groups. By default groups 0-8 have the timeout enabled, group 9's timeout is disabled. This is useful for background music.

Assigning Priority for standard multicast paging

The **PA-250-IP** will prioritize simultaneous Multicast audio streams according to their priority in the Paging Sources list. Group 0 will have the highest priority while group 9 will have the lowest priority. Group 9 is useful for a low priority stream such as background music. Group 0 is useful for high priority streams such as emergency messages.

The multicast paging groups can also be used for up to ten different paging zones for receiving audio streams. A paging zone can consist of one or many **PA-250-IP** multicast paging amplifiers. There is no limit to how many paging amplifiers can be in a given paging zone. Each multicast group is defined by a multicast address and port number. Each multicast group is assigned a priority, allowing simultaneously arriving pages to be serviced based on importance.

Polycom

Polycom IP phones send multicast audio to a specific IP address and port. A total of 25 groups can be used, with group 25 generally reserved for an emergency broadcast. Set the Multicast Page Type to “Polycom” (“Amplifier Settings” tab). The Viking IP programming page will then show “Polycom Paging Source and Group Subscriptions” on the “Codes/Paging” tab. Polycom phones will default to IP address 224.0.1.116 and port 5001 for multicast. Under “Polycom Paging Source and Group Subscriptions”, enter the IP address and port you chose in the Polycom IP phone as “Multicast IP address” and “port” (Paging/PTT Configuration page). Select the paging groups the **PA-250-IP** should subscribe to. Any multicast audio sent to the correct IP address, port number and a subscribed group will be heard from both the Speaker Out and 600 Ohm Out terminals. Group 1 is the lowest priority and group 25 is the highest. The Volume and Timeout can be selected globally, although the timeout does not affect group 25.

Factory Setting: All Groups selected

12. Multicast Paging Volume

The volume of each individual standard multicast page can be adjusted from 0 - 19. **Factory Setting:** 1
When polycom paging is used, the paging volume is set globally for all 25 groups.
Multicast volume is also controlled by the PAGE volume Pot on the front panel.

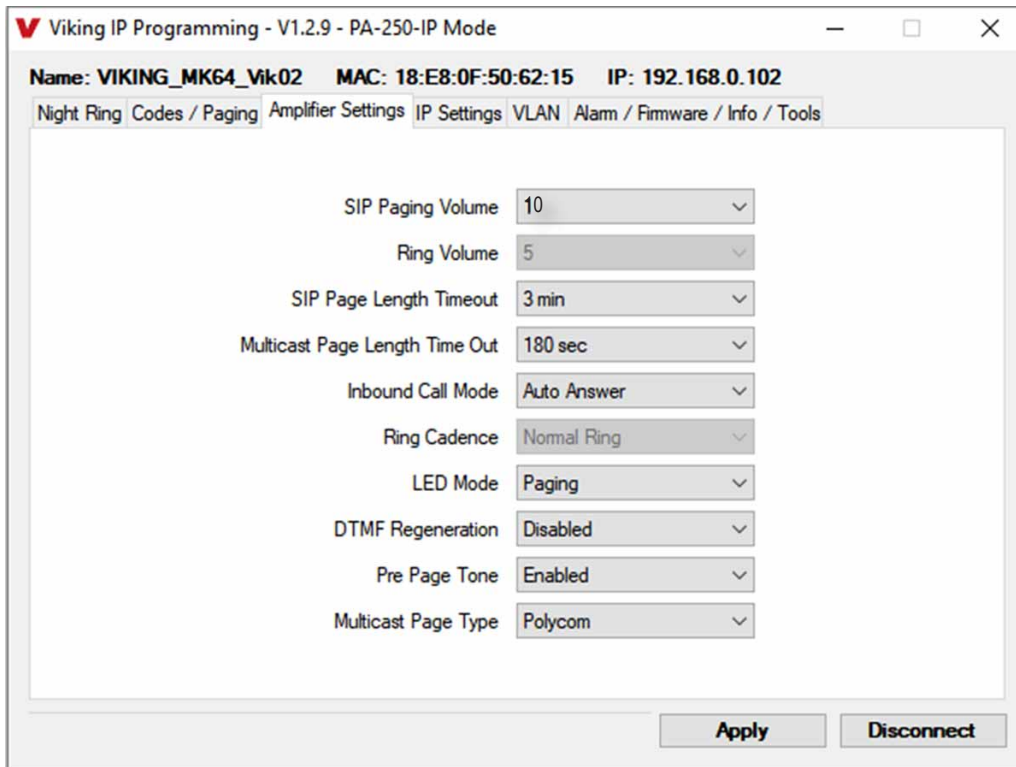

13. SIP Paging Volume

The SIP Paging volume can be set from 0 - 19. 0 = lowest volume setting, 19= highest volume setting.

Factory Setting: 10

Adjusting this will set the volume level for SIP Paging. SIP Paging volume is also controlled by the PAGE volume Pot on the front panel.

14. Ring Volume

When the Inbound Call Mode (see Programming section 22) is set to Ring, the **PA-250-IP** will output a loud ring when it is called. The volume level of the loud ring can be adjusted from 0 - 19. **Factory Setting:** 5

15. SIP Page Length Timeout

This feature selects the maximum length of time that incoming SIP calls can be connected. Programmable in increments of 1 minute up to a maximum of 9 minutes or disabled. With the call length disabled, the **PA-250-IP** must rely on a call ended signal or touch tone # to hang-up. **Factory Setting:** 3 minutes

16. Multicast Page Length Timeout

The Multicast Page Length Timeout can be programmed from 1 to 255 seconds in one second increments. The Time Out can also be disabled, allowing any length of Multicast page or continuous background music. When using standard Multicast Paging, a timeout checkbox can be individually enabled or disabled for each multicast paging group (on the "Codes/Paging" tab). When using Polycom Multicast Paging, the timeout checkbox enables the timeout globally on groups 1 through 24. There is no timeout for a page to the emergency group 25. **Factory Setting:** 180 seconds.

17. Inbound Call Mode

The Inbound Call Mode determines how the **PA-250-IP** handles incoming SIP calls. One option is to generate a loud ring sound. The **PA-250-IP** can also auto answer the call, to allow SIP paging. The “secure” option for auto answer require the callers to dial the access code in order to transmit a page.

Factory Setting: Auto Answer

Disabled – Inbound SIP calls are not allowed.

Auto Answer – Inbound SIP calls are auto answered on the first ring and can page over the audio outputs.

Auto Answer Secure – Inbound SIP calls are auto answered and the caller must dial the access code in order to make a page.

Ring: In the “Ring” mode the unit will not automatically answer an incoming SIP call but will output a loud ring signal in a factory programmed 2 seconds on, 4 seconds off ring pattern (pattern / cadence is selectable).

18. Ring Cadence

When the **PA-250-IP** is set to loud ring on incoming SIP calls, you can select the ring cadence of the loud ring sound. It can be programmed to one of four different cadences. **Factory Setting:** Normal Ring

Normal Ring (single ring: 2 seconds ON, 4 seconds OFF) factory setting

Double Ring (double ring: 1 second ON, 0.5 second OFF, 1 second ON, 3.5 seconds OFF)

Short-Short-Long (triple ring: 0.5 second ON, 0.5 second OFF, 0.5 second ON, 0.5 second OFF, 1 second ON, 3 seconds OFF)

Short-Long-Short (triple ring: 0.5 second ON, 0.5 second OFF, 1 second ON, 0.5 second OFF, 0.5 second ON, 3 seconds OFF)

19. LED Mode

The “Page / Status” LED on the **PA-250-IP** can be programmed to one of three different modes.

Factory Setting: Paging Mode

OFF Mode: In this mode the LED will not light during normal operation. It will only light (blink) if it cannot register with the programmed SIP server or while manually resetting all network parameters to factory default.

On Mode: The LED will remain ON when the unit is powered and registered. The LED will flash if registration is lost and alarm is active.

Paging Mode: The LED will remain OFF in the idle state, light steady when the page is active, then turn OFF when the call is completed. The LED will also light steady during Multicast paging.

20. DTMF Regeneration

When DTMF Regeneration is Enabled, any touch tones entered by the caller (in band or out of band) will be passed along to the line out and speaker out. These tones are used by a zone controller or external amplifier to choose which zone to send the page audio to. **Factory Setting:** Disabled

21. Pre Page Tone

When enabled, a short beep will be heard prior to SIP or standard Multicast paging audio. The volume of the Pre Page Alert Tone will match the volume setting of the SIP or standard Multicast page. **Factory Setting:** Enabled

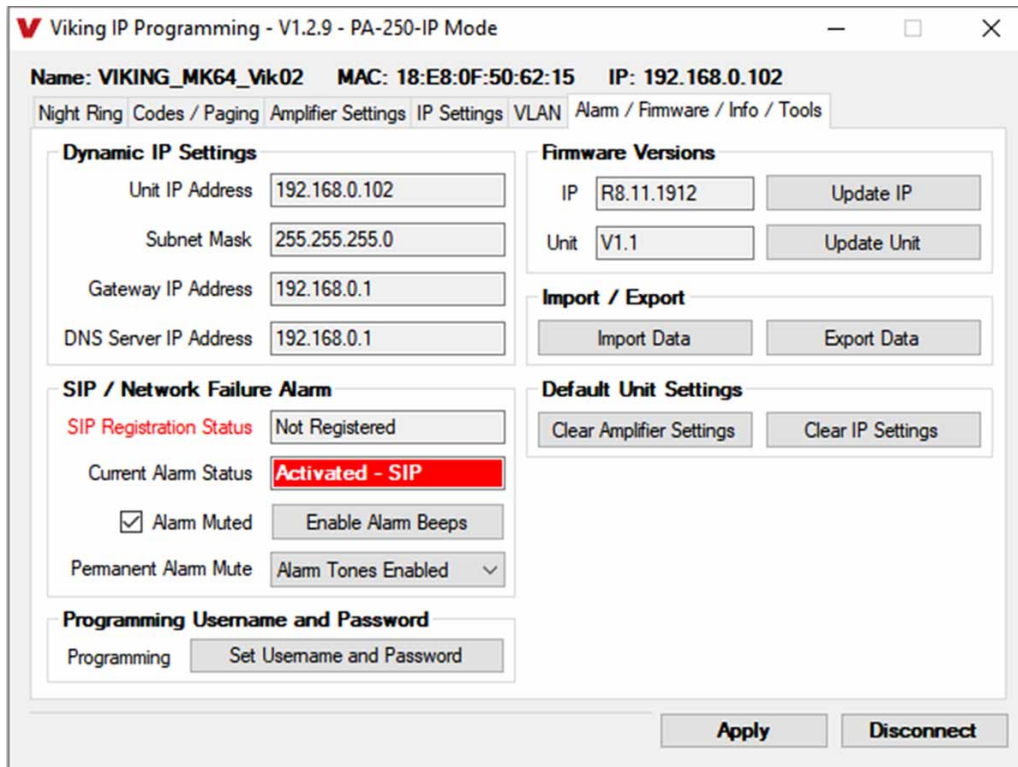

22. Mute Current / Next Alarm

A network failure alarm will be indicated by providing 3 beeps over both audio outputs every 30 seconds but only when Permanent Alarm Mute is set to Alarm Tones Enabled (Permanent Alarm Mute is set to Alarm Tones Disabled by default). A network failure indicates the unit is not registered to the SIP server or there is a communication failure with the gateway. The three beeps can be muted by clicking on “Mute Current / Next Alarm” button in the IP Programming software or pressing and holding the Reset button for five seconds. The Status LED will continue to flash to assist troubleshooting. The alarm beeps can also be permanently disabled. See Permanent Alarm Mute below. **Factory Setting:** Disabled

23. Permanent Alarm Mute

Permanent Alarm Mute is set to Alarm Tones Disabled by default, so network failure alarms will not be indicated over the audio outputs. Only the status LED will flash to indicate the network failure. To enable alarm tones over the audio outputs, select Alarm Tones Enabled.

24. Programming a Username and Password to Restrict Access to Programming

To increase security, a username and password can be programmed to limit access to the **PA-250-IP** using Viking IP Programming software. When no username and password are programmed and the security code is still set to default (845464), the PC software will not require a username, password or security code when connecting to the **PA-250-IP**. If the **PA-250-IP** has been programmed with a username and password, a pop up window will ask for the username followed by the password. If the unit’s security code has been changed from default (845464), it will then prompt for the correct security code.

If the username and password are unknown, they can only be erased by resetting all network parameters to default with the Reset button (see section E on page 7). If the username and password are known but you wish to erase them, that can be accomplished by exporting the data from the **PA-250-IP**, resetting all network parameters to default with the Reset button (see section E on page 7) or clicking on “Clear IP Settings” and then importing the data back into the **PA-250-IP**.

25. IP Firmware

Update IP is currently not available. The ability to update IP firmware will be made available in a later release of Viking IP Programming software. If an IP firmware update is needed, Viking Technical Support will assist in updating the IP firmware.

26. Unit Firmware

If new Unit firmware is available, after opening the programming software a pop up window will ask if you would like to update the firmware. Another way to update is accomplished by clicking the “Update Unit” button. You can then browse to the folder that contains the HEX file for updating the unit’s firmware. This method is typically only used when Viking Technical Support has sent you updated firmware.

27. Import / Export

The Import/Export feature is useful for backing up all the **PA-250-IP's** programming or for importing programming when installing multiple units with a majority of the same programming.

28. Clear Amplifier Settings

Clicking on the “Clear Amplifier Settings” button in programming will reset all of the programming features back to their factory default settings, including setting the unit’s security code back to the default value (845464).

NOTE: This command will not change or reset your IP settings or Multicast paging settings.

29. Clear IP Settings

Clicking on the “Clear IP Settings” will reset all of the IP settings back to their factory default settings. This also clears Multicast IP address / port settings and erases any username and password programmed in the unit to restrict access to programming.

The screenshot shows the 'Viking IP Programming - V1.2.9 - PA-250-IP Mode' window. At the top, it displays the unit's Name: VIKING_MK64_Vik02, MAC: 18:E8:0F:50:62:15, and IP: 192.168.0.102. Below this is a navigation bar with tabs: Night Ring, Codes / Paging, Amplifier Settings, IP Settings, VLAN, Alarm / Firmware / Info / Tools. The 'Night Ring' tab is selected, showing two main sections: 'Night Ring Timed Operation' and 'Time Zone Settings'.
In the 'Night Ring Timed Operation' section:
- 'Night Ring Time Control' is set to 'Disabled'.
- 'Night Ring Start Time' is set to 17:00.
- 'Night Ring Stop Time' is set to 8:00.
- 'Time Control Active Days' has checkboxes for Su, Mo, Tu, We, Th, Fr, Sa, all of which are currently unchecked.
In the 'Time Zone Settings' section:
- 'Time Zone' is set to '(UTC - 06:00) CST'.
- 'Daylight Saving Time' is set to 'Disabled'.
- 'DST Begins' is set to '2nd Sunday of March'.
- 'DST Ends' is set to '1st Sunday of November'.
At the bottom right of the window are 'Apply' and 'Disconnect' buttons.

30. Night Ring Timed Operation

When Night Ring Timed Operation is enabled, if a SIP call is received during the programmed Start and Stop times, the **PA-250-IP** will output loud ring on the “600 Ohm Output” and “Speaker Out” terminals. This is selectable for each day of the week. When outside of the Night Ring timing window, the Inbound Call Mode setting will determine how SIP calls are handled.

NOTE: For timed Night Ringing the unit must be synced with a time server. If the Night Ringing feature is enabled in the software you will be asked to use Viking’s Time Server when changes are applied. The address will be entered by the software automatically.

31. Time Zone Settings

When using the Night Ring Timed Operation, the **PA-250-IP** must be synced with the network time. Set the Time Zone Settings to match the settings on the network the unit is connected to for proper timed operation.

A. Inbound SIP Calls

How inbound SIP calls are handled depends on the Inbound Call Mode selected (see Programming section 18), the current programming for Night Ring Timed Operation if enabled (see Programming section 31), the current time of day and day of week. If Night Ring Timed Operation is disabled and the Inbound Call Mode is set to Auto Answer, the **PA-250-IP** will automatically answer inbound calls, provides a Pre Page Alert Tone if enabled and allows paging. When the Inbound Call Mode is set to Auto Answer – Secure, the **PA-250-IP** auto answers inbound calls but the party must dial the Access Code before they are allowed to page. The Inbound Call Mode also has a Ring option that allows the unit to output a loud ring on any inbound SIP calls and the volume of the ring is adjustable (see Programming section 15). If Night Ring Timed Operation is enabled and an inbound SIP call is received between the programmed start and stop times and the current day is a programmed active day, the unit will automatically output a loud ring instead of following the Inbound Call Mode programming. This allows for loud ring at certain times of the day/days of the week and paging all other times/days of the week.

B. Multicast

The **PA-250-IP** can be set to one of two modes for multicasting, Standard or Polycom. Polycom is only used when Polycom IP phones are used. To change to Polycom multicasting, go to the “Amp Settings” tab and change the “Multicast Page Type” to Polycom.

Standard Multicast Paging (Factory Setting)

Up to 10 multicast paging groups can be programmed into each unit and each group is assigned a priority level allowing simultaneous arriving multicast pages to be handled based on importance. Low priority groups are often used for low priority streams like background music and high priority groups are used for high priority streams such as emergency messages. Group 0 is the highest priority, and Group 9 is the lowest. A timeout limit can be set and either enabled or disabled for each multicast group. The volume of each group can be programmed and SIP calls can be assigned either higher or lower priority than all or some of the multicast groups (see Programming section 10).

Polycom Multicast Paging

Polycom phones send multicast audio to a specific IP address and port. A total of 25 groups can be used and groups 1 through 24 can individually be enabled/disabled in each **PA-250-IP**. Group 25 is always enabled, as group 25 is generally used for emergency broadcasts. Any multicast page made from a Polycom phone (on the same LAN) to the programmed IP address, port and to an enabled group will play through the **PA-250-IP**'s speaker and 600 Ohm outputs. The priority of Polycom sources ranges from group 1 (lowest) to group 25 (highest). SIP pages can be assigned either higher or lower priority than Polycom group 1 through 24 multicast paging (see the table in programming section 10 for Polycom paging priorities). Multicast page timeout can be enabled/disabled globally for groups 1 through 24 (there is no timeout for group 25) and the length of the Multicast page timeout is adjustable. The volume for Polycom multicast is set globally for all groups.

C. Inputs

In the idle state, the **PA-250-IP** allows Background Music to the speakers. When “Page” or “AUX” audio inputs are activated, background music is muted and the activated input is connected. Each input, except Background Music, has front panel LEDs that light up showing status of activity and audio level. If multiple inputs are activated, the **PA-250-IP** will manage them via the following Input Priority; “Page”, “AUX” then “Background Music”. Chime Tones will barge in on top of any active page. When no inputs are active, the **PA-250-IP** will fade back to background music.

D. ALC Adjustment

The front panel **ALC** (Automatic Level Control), adjustment POT allows up to 6dB of dynamic audio compression. When used, it increases the level of soft spoken pages, and decreases the level of loud spoken pages. It is useful to help nominalize the volume of voice paging from SIP and Multicast Paging. When dialed back to minimum, the **ALC** feature is disabled.

E. Bass and Treble Controls

Front panel **BASS** and **TREBLE** controls are provided to adjust the paging tonality. Since lower frequencies require higher power, turning the bass down can allow increased paging volume levels. Turning up the treble can increase paging intelligibility.

F. Master Volume Control and Peak Limiter

The front panel **MASTER VOLUME** control adjusts the volume coming from all inputs.

The **PA-250-IP** has an integrated Peak Limiter feature that reduces the audio signal peaks by 4dB. Since audio signals are highly dynamic in nature, this feature allows the average volume level of pages to be 4dB louder than normal before clipping distortion occurs. The **MASTER VOLUME** LED blinks on when peak limiting is engaging. If maximum volume levels are desired, turn up the **MASTER VOLUME** control until the **MASTER VOLUME** LED starts blinking a bit during pages. Then use the 70V speaker taps to adjust the volume of each paging speaker, keeping in mind to NOT go over a total of 250 Watt accumulative load.

G. Power LED

The front panel **POWER** LED serves two purposes. It will light steady a few seconds after the unit is powered up showing power is applied. Second, it will momentarily wink showing when the power amplifier is going into current limiting. If current limiting is observed, here is a list of suggested actions:

Step 1	Turn down the input level of the specific input that is pushing it into current limiting.
Step 2	Turn down the MASTER VOLUME level.
Step 3	Turn down the BASS level.
Step 4	Reduce the number of speakers connected to the PA-250-IP .
Step 5	Reduce the power tap settings of the connected speakers.

Troubleshooting

If the unit cannot register with the programmed SIP server, the Status LED will blink on and off every second until communication is restored. This alerts a potential user of a problem with the device that will prevent a page from being made.

Cost Effective Paging Horns and Speakers for 70V Paging Systems

In outdoor, factory or warehouse environments, **25AE-70V** paging horns are the best method of producing understandable sound. In these environments the directional design allows the installer to focus the sound cone down aisles and toward work areas.

The **25AE-70V** paging horn provides a built-in step-down transformer for use with 25V or 70V paging systems such as Viking models **PA-30**, **PA-60**, **PA-250**, **PA-250-IP** and **PP-250**. The transformer has a range of 5 separate switch selectable power taps, which can be used to adjust the volume of each speaker. These higher voltage distributed audio paging systems also have the advantage of being able to connect more speakers using lighter gauge wire runs while having less volume lost in wire resistance. This saves wiring costs compared to 8 Ohm systems. etc. For more info, see **DOD 471**.



**Model
25AE-70V**



Model 30AE-70V

In office and restaurant environments, it is best to distribute sound more evenly. Ceiling mounted **30AE-70V** speakers in close proximity offer the best distribution and are cost effective.

The **30AE-70V** ceiling speaker provides a built-in step-down transformer for use with 25V or 70V paging systems such as Viking models **PA-30**, **PA-60**, **PA-250**, **PA-250-IP** and **PP-250**. The transformer has a range of 5 separate power taps, which can be used to adjust the volume of each speaker. These higher voltage distributed audio paging systems also have the advantage of being able to connect more speakers using lighter gauge wire runs while having less volume lost in wire resistance. This saves wiring costs compared to 8 Ohm systems. For more info, see **DOD 473**.

High Power Weather Resistant Paging Horn for Use with 8 Ohm or 25V / 70V Systems

The **300AE** paging horn provides a built-in step-down transformer for use with 25V or 70V paging systems such as Viking models **PA-30**, **PA-60**, **PP-250**, **PA-250**, **PA-250-IP**. The transformer has a range of power taps that are selectable with a 6 position rotary switch, so that installers are able to independently adjust the volume of each paging horn. These higher voltage paging systems also have the advantage of being able to connect more speakers using lighter gauge wire runs and still have less volume lost in wire resistance.

The **300AE** weather resistant design allows for use in outdoor, factory, or warehouse environments. Its larger size and greater frequency response provide greater intelligibility of voice pages and is suitable for background music. The directional design allows the installer to focus the sound cone down aisles and toward work areas. The included mounting hardware provides full adjustment of horizontal and vertical positioning. For more info, see **DOD 497**.



**Model
300AE**

Tile Bridge for Ceiling Speakers



**Model
SA-TBA**

The **SA-TBA** is a tile bridge designed to mount 8 inch loud speaker and bridges both 2 ft x 2 ft and 2 ft x 4 ft ceiling tiles. It is compatible with the Viking models **SA-1S**, **30AE**, **35AE**, and **40AE** speakers. The **SA-TBA** tile bridge is constructed of 24 gauge cold rolled steel with an electro galvanized rust-resistant finish. For more info, see **DOD 534**.

Related Products

250 Watt / 70V Paging Power Amplifier



Model PP-250

For more info, see **DOD 511**.

The **PP-250** is a 250 Watt 70V Paging Power Amplifier that can drive up to two hundred fifty (250) 70V speakers and/or paging horns (each speaker set to "1 Watt tap"). The small 1U rack size chassis is possible because the **PP-250** uses new amplifier technology that is 3 times more efficient than old designs competitors use. The high efficiency of the **PP-250** means much less heat dissipation, smaller size, higher reliability, and lower cost.

The **PP-250** can be used to add power amplification to a phone system paging port, Viking's remote access device (**RAD-1A**), clock controlled tone generators (**CTG-1A**, **CTG-2A**), mass notification announcer (**DNA-510**), digital announcers (**DVA-2WA**, **K-2000-DVA**), zone paging controller (**ZPI-4**), or to expand the paging power capability of these Viking products: **PA-IP**, **PA-2A**, **PA-15**, **PA-30**, **PA-250**, and **PA-250-IP**.

250 Watt / 70V Telecom Paging Amplifier



Model PA-250

For more info, see **DOD 501**.

The **PA-250** is a 250 Watt 70V Telecom Paging Amplifier that can drive up to two hundred fifty (250) 70V speakers and/or paging horns (each speaker set to "1 Watt tap"). The small 1U rack size chassis is possible because the **PA-250** uses new amplifier technology that is 3 times more efficient than old designs competitors use. The high efficiency of the **PA-250** means much less heat dissipation, smaller size, higher reliability, and lower cost.

There are many advantages of using a 70V distributed audio paging system, such as being able to put more speakers on a wire run, having longer speaker wire runs, using smaller gauge wire, and being able to set the volume of each speaker independently.

15 Watt Paging Amplifier with Background Music and Loud Ringing

The **PA-15** interfaces with virtually any telephone system to provide 15 Watts of paging power - enough to drive fifteen 8-Ohm paging horns or speakers. This small and light weight chassis design is possible by utilizing new amplifier technology that is 300% less inefficient than old designs competitors use. High efficiency means much less heat disipation, smaller size, higher reliability, and lower cost.

The **PA-15** provides 36V talk battery for interfacing with an **FXO** or unused analog line input/trunk port. With the flip of a switch, the unit can connect to a **FXS** or PABX/Centrex station ring trip port or connect to a 600 Ohm paging port. When interfacing with systems that do not provide a paging contact closure, the built-in voice activation (**VOX**) is in control.

For more information on the **PA-15**, see **DOD 486**.



15 Watt Paging Amplifier with Background Music and Loud Ringing

The **PA-30** can directly drive up to thirty (30) 8 Ohm paging speakers or fifty (50) 70V or 25V paging speakers. This small and light weight chassis design is possible by utilizing new amplifier technology that is 300% less inefficient than old designs competitors use. High efficiency means much less heat disipation, smaller size, higher reliability, and lower cost.

The **PA-30** provides loud ringing and paging to electronic key systems, 1A2 Key systems, PABX's as well as No-KSU phones and multi-line phones. The **PA-30** eliminates the installation of multiple bells, relays and paging cards. The unit comes complete with a power supply, and integrated 30 Watt amplifier.

For more information on the **PA-30**, see **DOD 489**.



60 Watt Compact Two Zone Amplifier to Drive 60 Paging Speakers

The **PA-60** can directly drive up to sixty (60) 8 Ohm paging speakers or one hundred (100) 70V or 25V paging speakers. Both channels can be fed the same input so the **PA-60** can be used as a single large amplifier, or each channel can be fed different inputs so the **PA-60** can be used as a two zone amplifier.

Since each input has its own gain adjustment, one zone can be turned up louder for warehouse paging horn speakers, and the other zone can be turned down for office ceiling speakers. Two zones can also be helpful for installations in which one group of speakers is connected to a source that provides background music using the Viking **PI-1A** Paging Interface unit, and the other zone provides only paging.

For more information on the **PA-60**, see **DOD 493**.

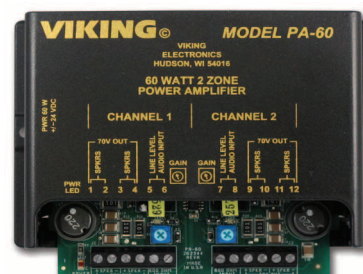

Warranty

IF YOU HAVE A PROBLEM WITH A VIKING PRODUCT, CONTACT VIKING TECHNICAL SUPPORT: 715-386-8666

Our Technical Support Department is available for assistance Monday through Friday 8:00am to 5:00pm central time. Before you call, please:

1. Know the model number, the serial number and what software version you have (see serial label).
2. Have the Product Manual in front of you.
3. It is best if you are on site.

RETURNING PRODUCT FOR REPAIR

The following procedure is for equipment that needs repair:

1. Customer must contact Viking's Technical Support Department at 715-386-8666 to obtain a Return Authorization (RA) number. The customer MUST have a complete description of the problem, with all pertinent information regarding the defect, such as options set, conditions, symptoms, methods to duplicate problem, frequency of failure, etc.
2. Packing: Return equipment in original box or in proper packing so that damage will not occur while in transit. The original product boxes are not designed for shipping - an overpack box is required to prevent damage in transit. Static sensitive equipment such as a circuit board should be in an anti-static bag, sandwiched between foam and individually boxed. All equipment should be wrapped to avoid packing material lodging in or sticking to the equipment. Include ALL parts of the equipment. C.O.D. or freight collect shipments cannot be accepted. Ship cartons prepaid to: **VIKING ELECTRONICS
1531 INDUSTRIAL STREET
HUDSON, WI 54016**
3. Return shipping address: Be sure to include your return shipping address inside the box. We cannot ship to a PO Box.
4. RA number on carton: In large printing, write the RA number on the outside of each carton being returned.

RETURNING PRODUCT FOR EXCHANGE

The following procedure is for equipment that has failed out-of-box (**within 10 days of purchase**):

1. Customer must contact Viking's Technical Support at 715-386-8666 to determine possible causes for the problem. The customer MUST be able to step through recommended tests for diagnosis.
2. If the Technical Support Product Specialist determines that the equipment is defective based on the customer's input and troubleshooting, a Return Authorization (RA) number will be issued. This number is valid for fourteen (14) calendar days from the date of issue.
3. After obtaining the RA number, return the approved equipment to your distributor. Please reference the RA number on the paperwork being shipped back with the unit(s), and also the outside of the shipping box. The original product boxes are not designed for shipping - an overpack box is required to prevent damage in transit. Once your distributor receives the package, they will replace the product over the counter at no charge. The distributor will then return the product to Viking using the same RA number.
4. **The distributor will NOT exchange this product without first obtaining the RA number from you. If you haven't followed the steps listed in 1, 2 and 3, be aware that you will have to pay a restocking charge.**

TWO YEAR LIMITED WARRANTY

Viking warrants its products to be free from defects in the workmanship or materials, under normal use and service, for a period of two years from the date of purchase from any authorized Viking distributor. If at any time during the warranty period, the product is deemed defective or malfunctions, return the product to Viking Electronics, Inc., 1531 Industrial Street, Hudson, WI., 54016. Customer must contact Viking's Technical Support Department at 715-386-8666 to obtain a Return Authorization (R.A.) number.

This warranty does not cover any damage to the product due to lightning, over voltage, under voltage, accident, misuse, abuse, negligence or any damage caused by use of the product by the purchaser or others. This warranty does not cover non-EWP products that have been exposed to wet or corrosive environments. This warranty does not cover stainless steel surfaces that have not been properly maintained.

NO OTHER WARRANTIES. VIKING MAKES NO WARRANTIES RELATING TO ITS PRODUCTS OTHER THAN AS DESCRIBED ABOVE AND DISCLAIMS ANY EXPRESS OR IMPLIED WARRANTIES OR MERCHANTABILITY OR FITNESS FOR ANY PARTICULAR PURPOSE.

EXCLUSION OF CONSEQUENTIAL DAMAGES. VIKING SHALL NOT, UNDER ANY CIRCUMSTANCES, BE LIABLE TO PURCHASER, OR ANY OTHER PARTY, FOR CONSEQUENTIAL, INCIDENTAL, SPECIAL OR EXEMPLARY DAMAGES ARISING OUT OF OR RELATED TO THE SALE OR USE OF THE PRODUCT SOLD HEREUNDER.

EXCLUSIVE REMEDY AND LIMITATION OF LIABILITY. WHETHER IN AN ACTION BASED ON CONTRACT, TORT (INCLUDING NEGLIGENCE OR STRICT LIABILITY) OR ANY OTHER LEGAL THEORY, ANY LIABILITY OF VIKING SHALL BE LIMITED TO REPAIR OR REPLACEMENT OF THE PRODUCT, OR AT VIKING'S OPTION, REFUND OF THE PURCHASE PRICE AS THE EXCLUSIVE REMEDY AND ANY LIABILITY OF VIKING SHALL BE SO LIMITED.

IT IS EXPRESSLY UNDERSTOOD AND AGREED THAT EACH AND EVERY PROVISION OF THIS AGREEMENT WHICH PROVIDES FOR DISCLAIMER OF WARRANTIES, EXCLUSION OF CONSEQUENTIAL DAMAGES, AND EXCLUSIVE REMEDY AND LIMITATION OF LIABILITY, ARE SEVERABLE FROM ANY OTHER PROVISION AND EACH PROVISION IS A SEPARABLE AND INDEPENDENT ELEMENT OF RISK ALLOCATION AND IS INTENDED TO BE ENFORCED AS SUCH.

Product Support: 715-386-8666

Due to the dynamic nature of the product design, the information contained in this document is subject to change without notice. Viking Electronics, and its affiliates and/or subsidiaries assume no responsibility for errors and omissions contained in this information. Revisions of this document or new editions of it may be issued to incorporate such changes.