

# FIREWOLF

## BY NAPCO

### INSTALLATION INSTRUCTIONS FOR FWC-FSLC-EZM1B MINIATURE RESPONSE CONTACT MONITORING MODULE

The information contained in this installation instruction is a quick reference guide. For detailed system information refer to the panel manufacturers installation manual. This instruction is generic and will not address specific programming procedures.

#### GENERAL DESCRIPTION:

This instruction applies to the Miniature Response Contact Monitoring Module (FWC-FSLC-EZM1B) which is to be connected to a DCP Signaling Line Circuit (SLC). Typical applications are manual pull stations, water flow devices or any dry contact alarm device. This module can be wired in Class B (style B) only.

#### MOUNTING REQUIREMENTS:

The FWC-FSLC-EZM1B mounting option is shown in Fig 3. All the modules will follow Fig. 2A, 2B & 2C for wiring connections.

#### WIRING:

NOTE: All wiring must conform to local codes, ordinances and regulations.

- 1) Install module wiring in accordance with the job drawings and appropriate wiring diagram (see Fig. 2A, 2B & 2C).
- 2) Secure the module to a U.L. listed electrical box (supplied by installer) as shown in Fig. 3

TABLE 1: WIRING LIMITATIONS

Maximum Distance Between Module and EOL Device	
14 AWG	1500 Ft.
16 AWG	900 Ft.
18 AWG	550 Ft.

**CAUTION !!!**  
TO ENSURE PROPER OPERATION CONNECT THIS MODULE TO A COMPATIBLE FIRE CONTROL PANEL ONLY. REFER TO PANEL INSTRUCTIONS FOR PROPER CONNECTION AND COMPATIBILITY.

**CAUTION !!!**  
IF THIS MODULE WILL BE INSTALLED IN AN EXISTING OPERATIONAL SYSTEM, INFORM THE OPERATOR AND LOCAL AUTHORITY THAT THE SYSTEM WILL BE TEMPORARILY OUT OF SERVICE. DISCONNECT POWER TO THE CONTROL PANEL BEFORE INSTALLING THE MODULE.

#### ADDRESS PROGRAMMING CONNECTIONS:

To program the FWC-FSLC-EZM1B, connect the red alligator clip to the S(IN) terminal and the black alligator clip to the SC(IN) terminal (see figure 1). For proper address setting, polarity must be observed.

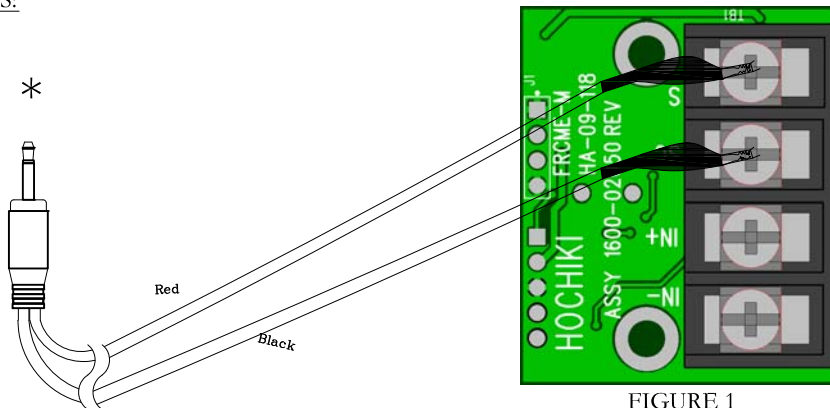

FIGURE 1

\* Insert programming jack into FWC-FSLC-PROG2 Address Programmer. See FWC-FSLC-PROG2 instructions for programming detail.

#### Note:

Radio Frequency Interference and Electro-Magnetic Interference are sources of noise that can adversely affect the fire alarm system's installation. Avoid running SLC circuits in the same conduit as power lines. Utilize twisted pair and shielded wire in environments where excessive noise is expected. When installing fire alarm system devices, avoid placing devices or wiring close to potential noise sources such as:

- Transmitters or antennas;
- Ballast lighting;
- Electrical motors;
- Large power transformers;
- Large machines.

SPECIFICATIONS	
SLC Applied Voltage	Rated Range 25.3 - 39 VDC
SLC Current Consumption	Maximum - 358μA Nominal - 339μA
EOL Device for Input	Part No. 0400-02350 10KΩ, 1/4W, 1/4inch
Operating Temperature Range	0°C (32°F) ~ 49°C (120°F)
Storage Temperature	-30°C (-22°F) ~ 70°C (158°F)
Maximum Relative Humidity	Up to 90% RH non-condensing
Environment	Indoor dry use only
Dimensions	1 3/4"W x 2 3/8"H x 0.5"D
Weight	Approximately 20.0 ounces

#### Note:

An average of 6.75mA (communication current) per loop of SLC devices, must be factored into the panel battery backup calculations.

Firewolf™ is a Registered trademark of NAPCO.



**Napco Security Systems, Inc.**  
333 Bayview Avenue \* Amityville, NY 11701  
Phone: (800) 645-9445 (631) 842-9400 Fax: (631) 789-3388

UL File# S5694

WI2078  
(PG 1 OF 2)

OUTPUT TO NEXT INTERFACE  
MODULE ON THE SLC LOOP

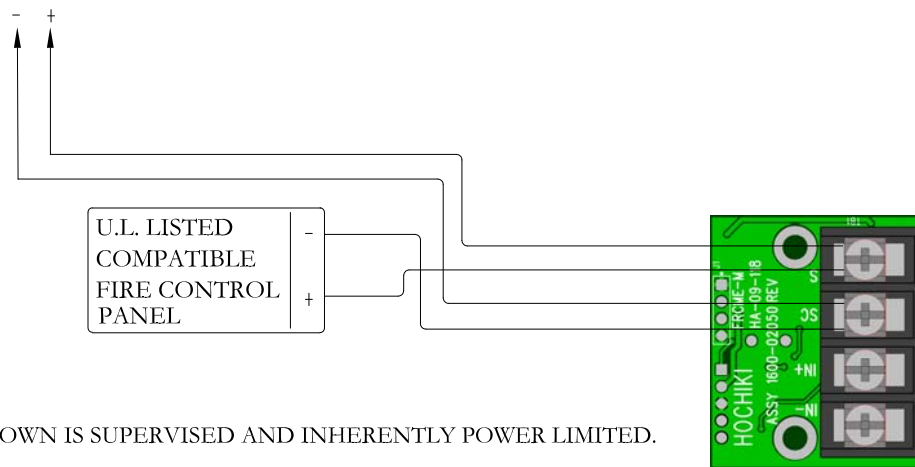

TB1 WIRING SHOWN IS SUPERVISED AND INHERENTLY POWER LIMITED.

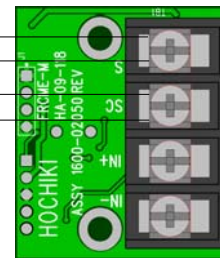

FIGURE 2A

WIRING DIAGRAM FOR CLASS B (STYLE B):

TYPICAL WIRING FOR N/O CONTACTS IN CLASS B (STYLE B)

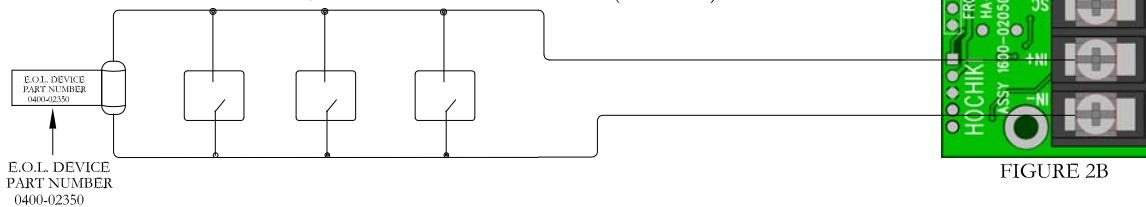

FIGURE 2B

TYPICAL WIRING FOR N/C CONTACTS

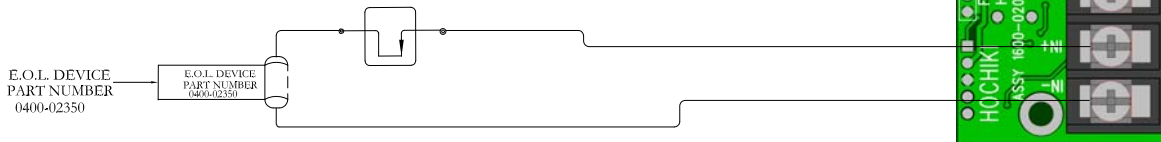

FIGURE 2C

**NOTE:** Only the same size wire from 12 to 22 AWG may be connected to the terminal block TB1 when more than one conductor is being connected under each terminal. Maximum of 2 conductor per terminal.

NOTE: For Normally Closed (N/C) contact monitoring, the FWC-FSLC-EZM1B can only be used to generate a trouble condition, not an alarm or supervisory.

NOTE: SLC Circuit is in reference to S, and SC for Class A/B wiring diagram.

MOUNTING OPTIONS:  
SECURE THE FWC-FSLC-EZM1B  
MODULE INTO ANY BACK BOX  
(SINGLE GANG SHOWN)

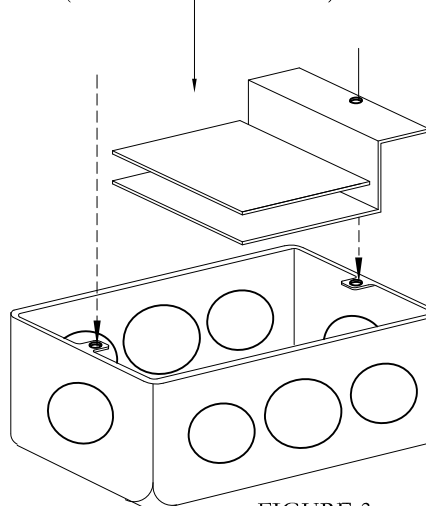

FIGURE 3

**CAUTION!**

- 1) DO NOT WIRE SLC LOOP INTO IN+ / IN- WIRES. THIS WILL RESULT IN DAMAGE TO THE MODULE!
- 2) DO NOT CONNECT MORE THAN ONE N/C CONTACT TO AN INPUT.

WIRING LIMITATIONS

Maximum line impedance between input and initiating devices.
3.50Ω