

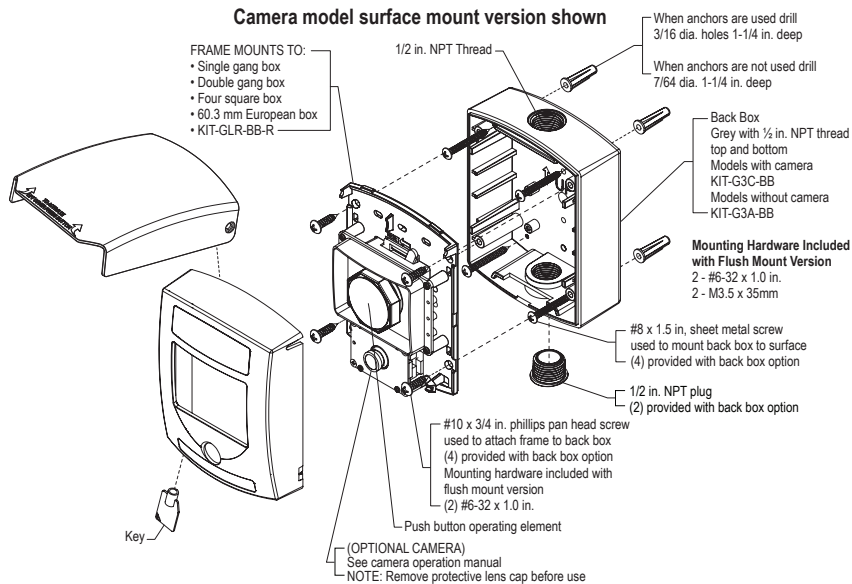

Installation Components



Pre Activation Alarm

Volume Jumper

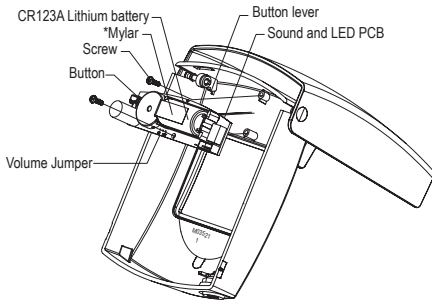
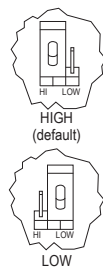

*Remove Mylar for sounder activation

Relay Specs

- Relay Terminal Rating
- DC: 30VDC, 1A
- AC: 30VAC, 0.3A

KIT-321 (Relay Wire Harness)

- Not included**
- Yellow: NO
 - Blue: COM
 - Green: NC
 - Red: External Power
 - Black: Ground

⚠ WARNING: This product can expose you to chemicals including Dichloromethane, which is known to the State of California to cause cancer, and Bisphenol A (BPA), which is known to the State of California to cause birth defects or other reproductive harm. For more information go to www.P65Warnings.ca.gov.

Three year warranty or a one year limited warranty (from date of purchase) on most products. See website for details. Electronic warranty form at www.sti-usa.com/wc14.

Mounting Options

Recommended mounting height is measured from the center of the push button to the floor level:

- 1. ADA/NFPA 101: 34 in. - 48 in.
- 2. European: 1.2 m - 1.6 m

NOTE: verify and comply with local AHJ

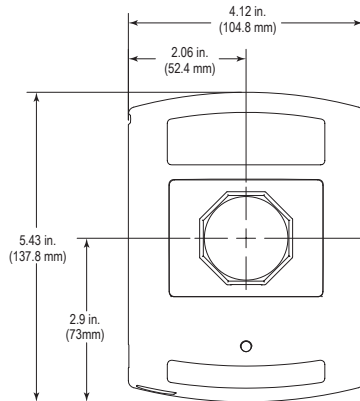

Frame mounting options recommended mounting height above finished floors:

- Not less than 3.5 ft. (1.1 m.)
- Greater than 4.5 ft. (1.37 m.)

Flush mount options

MOUNTING HOLE KEY	SCREW SIZE REQUIRED
KIT-GLR-BB-GY	#10 x 3/4 in. pan-sms
Four square box	#8-32 x 1.0 in. machine screw
Double gang box	#6-32 x 1.0 in. machine screw
60.3mm European box	M3.5 x 35mm machine screw
Single gang box	#6-32 x 1.0 in. machine screw

* "X" = COLOR OF BACK BOX

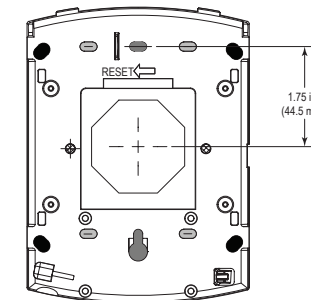

Back Box Installation prep.

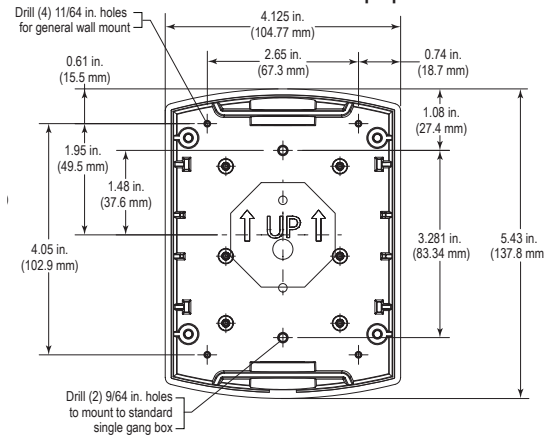

European electrical box

1. Remove four (4) screws to access mounting positions.
2. Mount the plate to an electrical box using two (2) M3.5 screws.
3. Place mechanism assembly on to the frame.
4. Insert four (4) screws.

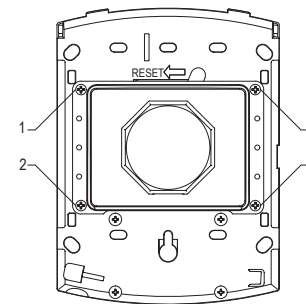

G3 SERIES

All specifications and information shown were current as of publication and are subject to change without notice. Visit our website for the latest version.

Mounting and Electrical Info

To unlock or lock cover

Insert security key.

1. To unlock, rotate counterclockwise.
2. To lock, rotate clockwise to secure cover.

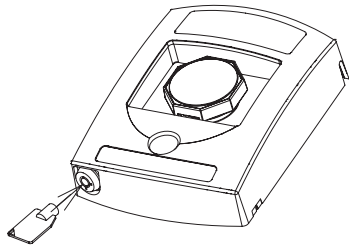

To remove cover

Pull bottom of unit out and pivot cover off tabs on frame.

To install cover

1. Insert tabs on the inside top of cover with slots on the frame.
2. Pivot cover down and snap bottom onto frame.

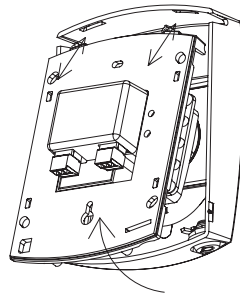

Terminal configuration

- INDOOR USE ONLY
- 14°F to 120°F (-10°C to 49°C)
- Two quick connect contact blocks DPDT
- Contact rating: 5A@ 30VAC, 5A@ 30VDC

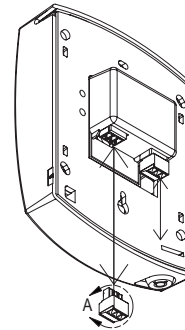

CORRECT METHOD Insert single lead

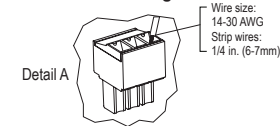

INCORRECT METHOD Inserting multiple leads



PCB marked for visual reference

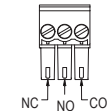

Latching Reset

For Key-to-Reset

- Remove cover

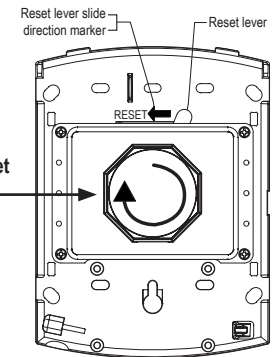

For Turn-to-Reset

- Turn button

Camera Info

Camera reset button
Camera accessory relay cable access

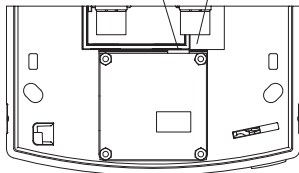

Camera user manual



Camera Power

- POE: IEEE802.3af, Class3, max 12W, 12 VDC ± 25%, 0.21A, max 2.5W
- Barrel connector for external power - 12 VDC, 1.2A

Relay Specs

- Relay Terminal Rating: 24VAC/DC, 2A



Relay Wire Harness

1. BLUE - Normally Open
2. RED - Common
3. YELLOW - Normally Closed
4. WHITE - Ground / I/O Ground
5. GREEN - I/O input

To change button function

1. Remove quick connect terminal blocks.
2. Push down and pivot terminal cover.
3. Change button function.
4. Reinstall terminal cover.
5. Re-insert quick connect terminal block.

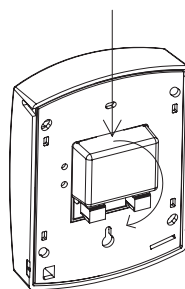

Changing Button Latching Function

Lower rotating disc must be visible
Key-to-reset screw position

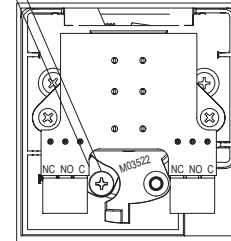

Key-to-Reset

1. With screw removed, slide reset lever until it stops, then release reset lever (you will now see a lower securing hole).
2. Insert screw into lower screw hole (screw must be flush).

NOTE: The screw will only be through one (1) hole before the securing hole. Test operation before final mounting.

Momentary screw position

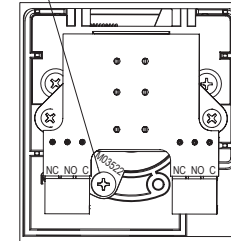

Momentary

1. With the screw removed, slide reset lever until fastening holes line up; then hold this position.
 2. Insert supplied screw until flush.
- NOTE: Screw will be through two (2) holes before the securing hole. Test operation before final mounting.

Turn-to-reset position

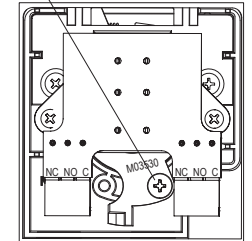

Turn-to-Reset

1. With screw removed, rotate octagon button clockwise 45°; then release the octagon.
 2. Insert supplied screw until flush.
- NOTE: Screw will be through two (2) holes before the securing hole. Test operation before final mounting.

G3 SERIES

All specifications and information shown were current as of publication and are subject to change without notice. Visit our website for the latest version.