

Installation and Setup Guide

GENERAL INFORMATION

The 5820L is a single-zone Slim-Line Door/Window contact transmitter that provides wireless notification of intrusion. The 5820L can be used only with alarm systems that support 5800 Series wireless devices. The 5820L has its own unique serial number permanently assigned during manufacture. You must enroll the transmitter's serial number in the control panel before it will operate in the system. Refer to the control panel's installation instructions for programming details.

Note: During programming of the control panel, 5820L transmitters must be enrolled as Input Type 3 (Supervised RF), Loop 1.

The transmitter is powered by one AAA Lithium (or alkaline) battery that is easily replaced when a low battery condition is indicated by the control panel.

TAMPER PROTECTION

Front and back-case tamper is provided using the same switch. The front-case tamper is always enabled. Adding the third screw as shown in Figure 2 enables the back-case tamper.

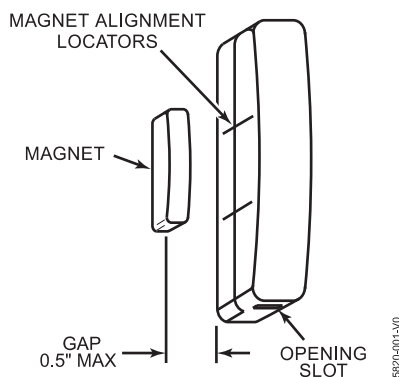

Figure 1. 5820L (Typical Installation Arrangement)

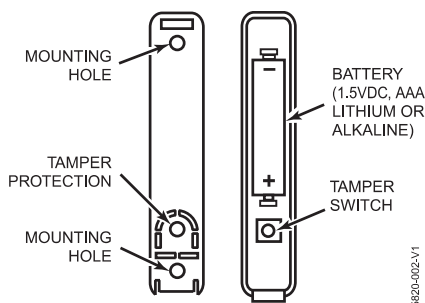

Figure 2. 5820L Mounting/Battery Location

MOUNTING

The description that follows assumes that the transmitter will be mounted as shown in Figure 1, with the magnet located adjacent to the unit's left side. The transmitter may, however, be installed in *any* direction, as long as the relationship of the unit to the magnet is maintained as shown in Figure 1.

1. **Temporarily** mount the 5820L and magnet using the double-back tape supplied.

Note: Before mounting the transmitter and magnet **permanently** using the double-back tape or mounting screws, conduct a *Go/No Go* test (see control's instructions) to verify adequate signal strength and reorient or relocate the transmitter if necessary.

2. If the *Go/No Go* test was successful, **remove the transmitter's cover** by inserting the flat blade of a small screwdriver into the opening slot at one end of the unit as shown in Figure 1, and separating the two halves.
3. The 5820L must only be mounted against a **flat** surface. A curved surface would cause undue stress to the unit and possible failure to operate properly.
4. Install **mounting** screws in the two outside mounting holes as shown in Figure 2 using a #1 Phillips.
5. If the case-back tamper switch will be used, install a third screw in the **middle** hole.
6. **Mount** the magnet (supplied) adjacent to the two vertical positioning lines on the case side (see Figure 1). The gap can be one-half an inch maximum.
7. To **reinstall** the cover, position the cover so that it covers the mounted case-back, and snap-shut. The two case halves can only be fitted together in one direction.

Note: Do **NOT** attempt to remove the PCB from the plastic cover for any reason.

BATTERY INSTALLATION/REPLACEMENT

Replace battery only with same or equivalent type. Dispose of used batteries according to the battery manufacturer's instruction.

Remove the transmitter's cover (if it is not off already) as described in *Mounting*; step 2.

1. **Observe correct polarity and insert the battery** provided into the battery retainer clips as shown in Figure 2.

Note: Replace battery *only* with type specified in the Specifications paragraph.

SPECIFICATIONS

Dimensions:3.0" H x 0.5" W x 0.8" D
76.2mm x 12.7mm x 20.3mm

Battery:1.5VDC, AAA Lithium (Energizer L92) or
AAA Alkaline, (Duracell MX2400,
Panasonic AM-4PI, Eveready Energizer
EN92)

Gap:0.5 inch maximum

Magnet: WA5816MAG (supplied)

BATTERY CAUTION: Risk of fire, explosion and burns. Do not recharge, disassemble, heat above 212° F (100° C) or incinerate. Dispose of used batteries properly. Keep away from children.

TO THE INSTALLER

Regular maintenance and inspection (at least annually) by the installer and frequent testing by the user are vital to continuous satisfactory operation of any alarm system. The installer should assume the responsibility of developing and offering a regular maintenance program to the user, as well as acquainting the user with the proper operation and limitations of the alarm system and its component parts. Recommendations must be included for a specific program of frequent testing (at least weekly) to insure the system's operation at all times.

FEDERAL COMMUNICATIONS COMMISSION STATEMENTS: The user shall not make any changes or modifications to the equipment unless authorized by the Installation Instructions or User's Manual. Unauthorized changes or modifications could void the user's authority to operate the equipment.

FCC/IC NOTICE: This device complies with Part 15 of the FCC Rules, and RSS-210 of IC. Operation is subject to the following two conditions: (1) This device may not cause harmful interference (2) This device must accept any interference received, including interference that may cause undesired operation.
Cet appareil est conforme à la partie 15 des règles de la FCC & de RSS-210 des Industries Canada. Son fonctionnement est soumis aux conditions suivantes: (1) Cet appareil ne doit pas causer d'interférences nuisibles. (2) Cet appareil doit accepter toute interférence reçue y compris les interférences causant une réception indésirable.

REFER TO THE INSTALLATION INSTRUCTIONS FOR THE CONTROL WITH WHICH THIS DEVICE IS USED, FOR DETAILS REGARDING LIMITATIONS OF THE ENTIRE ALARM SYSTEM.

Responsible Party / Issuer of Supplier's Declaration of Conformity: Ademco Inc., a subsidiary of Resideo Technologies, Inc., 2 Corporate Center Drive., Melville, NY 11747, Ph: 516-577-2000

The product should not be disposed of with other household waste. Check for the nearest authorized collection centers or authorized recyclers. The correct disposal of end-of-life equipment will help prevent potential negative consequences for the environment and human health.
Any attempt to reverse-engineer this device by decoding proprietary protocols, de-compiling firmware, or any similar actions is strictly prohibited.

SUPPORT & WARRANTY INFORMATION

For the latest documentation and support, please go to:
www.resideo.com

For the latest warranty information, please go to:
www.security.honeywellhome.com/warranty

The Honeywell Home Trademark is used under license from Honeywell International Inc.
This product manufactured by Resideo Technologies, Inc. and its affiliates



2 Corporate Center Drive, Suite 100
P.O. Box 9040, Melville, NY 11747
© 2020 Resideo Technologies, Inc.
www.resideo.com



K9232V2B 7/11 Rev. B