



**Safety Technology  
International**

# Wireless Doorbell Button

STI-34601

For use with STI Wireless Alert Series Receivers



## **Features and Specifications**

- 500' range, 433 MHz
- Commercial and residential applications
- Streamlined design
- ABS UV-stabilized material
- Low battery indicator on STI Wireless Alert Series Receiver
- Coin Cell Battery CR2032

**Rely on STI®**

Thank you for purchasing the STI Wireless Doorbell Button. Your satisfaction is very important to us. Please read this manual carefully to get the most from your new product.

## Installation Instructions

1. To remove cover, insert screwdriver, or other small device, at bottom of cover and depress gently. Rotate until tab disengages (Fig. 1).
2. Insert the battery by placing it under the top claws and then pushing battery into the bottom cradle (Fig. 2 and 3).
3. Attach backplate onto mounting surface with two included #6 – 32" screws (Fig. 4).
4. Snap cover back together (Fig. 4).
5. The Wireless Doorbell Button can now be enrolled into your 433 MHz Wireless Receiver. (Refer to receiver instructions for enrollment and programming.)

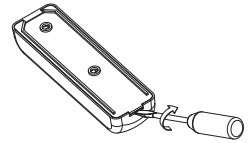

FIG. 1

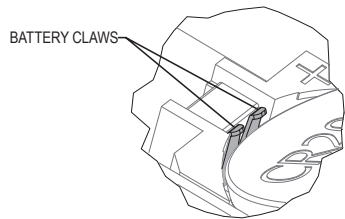

FIG. 2

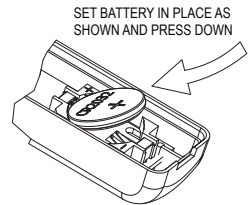
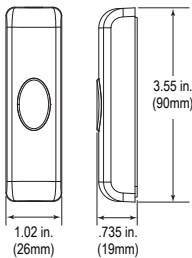

FIG. 3

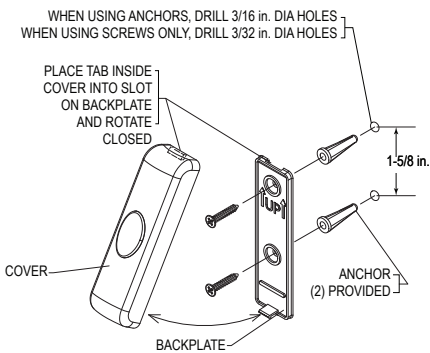

FIG. 4

## **Important Notice**

This device complies with Part 15 of the FCC Rules. Operation is subject to the following two conditions:

This device may not cause harmful interference.

This device must accept any interference that may be received, including interference that may cause undesired operation.

Changes or modifications not expressly approved by STI could void the user's authority to operate this equipment.

This product meets the applicable industry Canada Technical specifications.

Le Présent matériel est conforme aux spécifications techniques applicables d'Industrie Canada.

Model: 34601

FCC ID: TXL34601

IC: 6335A-34601

This device is a button transmitter intended for home and office use in all EU and EFTA member states.

## **Warranty**

Safety Technology International, Inc. warrants to the original consumer/purchaser that this product shall be free of defects in material and workmanship under normal use and circumstances for a period of one (1) year from the original date of purchase.

Electronic warranty form at **[www.sti-usa.com/wc14](http://www.sti-usa.com/wc14)**.

## **Technical Support**

Contact STI at 248-673-9898

## Additional Wireless Alert Series Products

STI-34098	Single Channel Slave Receiver	STI-6400WIR	Wireless Exit Stopper Door Alarm
STI-V34104	4-Channel Voice Receiver	STI-6400WIR4	Wireless Exit Stopper Door Alarm with Receiver
STI-34601	Wireless Doorbell Button	STI-6517A	Wireless Stopper Station Shield with Sound
STI-34752	Indoor/Outdoor Wireless PIR	STI-6517B	Wireless Stopper Station Shield with Sound and Transmitter
STI-6200WIR	Wireless Fire Extinguisher Theft Stopper	STI-6517C	Wireless Stopper Station Shield with Wireless Transmitter
STI-6200WIR4	Wireless Fire Extinguisher Theft Stopper with Receiver	STI-6517D	Wireless Stopper Station Shield with Button Sound and Transmitter
		STI-30105	Extended Antenna



USA



**Safety Technology  
International**



EMEA

2306 Airport Rd • Waterford, MI 48327, USA  
Phone: 248-673-9898 • [info@sti-usa.com](mailto:info@sti-usa.com) • [www.sti-usa.com](http://www.sti-usa.com)

Taylor House • 34 Sherwood Road • Bromsgrove, Worcestershire • B60 3DR • England  
Tel: +44 (0)1527 520 999 • [info@sti-emea.com](mailto:info@sti-emea.com) • [www.sti-emea.com](http://www.sti-emea.com)

Unit 7A • Lockhead Avenue • Airport Business Park • Waterford • X91 HWF2 • Ireland  
[info@sti-emea.com](mailto:info@sti-emea.com) • [www.sti-emea.com](http://www.sti-emea.com)