

SECTION B-B

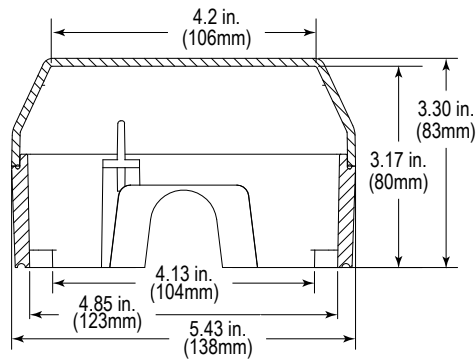

SECTION A-A

Three year warranty or a one year limited warranty (from date of purchase) on most products.  
See website for details. Electronic warranty form at [www.sti-usa.com/wc14](http://www.sti-usa.com/wc14).



USA

**STI-14200 SERIES UNIVERSAL STOPPER® LOW PROFILE - SURFACE MOUNT**

All specifications and information shown were current as of publication and are subject to change without notice.

STI-14200 SERIES JUNE2019



EMEA