

CPoEKPL384

Planning Instructions



CPL38 (4)



CPOE60W (1)



PLW162500 (1)

(2) End Wire Crimp Caps
(XCEW30648)

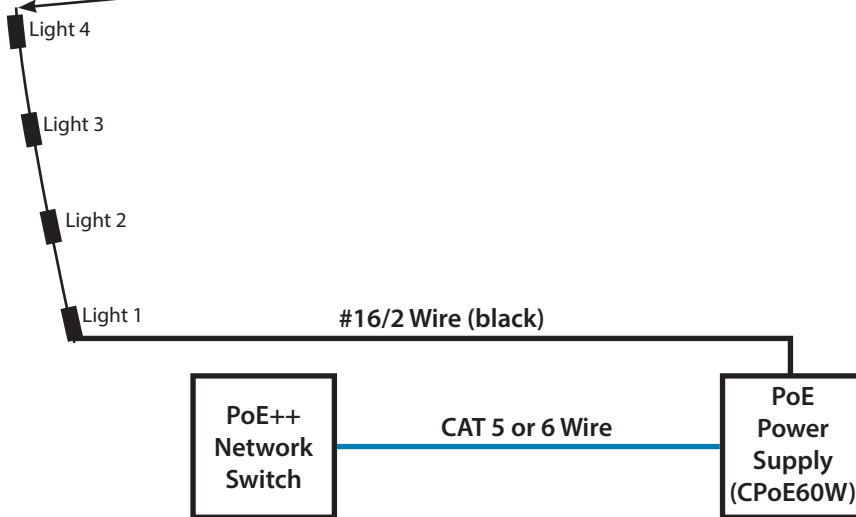

Installer can run the complete spool of #16/2 500' wire to power fixtures.

Questions on your system design?
Call CAST Lighting at 973-423-2303

Important: Follow all local electrical codes and requirements.

www.cast-lighting.com • 973-423-2303

Kit Contents

Please check that you received all of these components.

- (4) CAST LED Gen 3 Perimeter Lights (CPL38)
- (1) CAST Perimeter PoE 60 Watt (CPOE60W)
- (100) CAST Perimeter 11" Stainless Steel Ties (CPSSTIE11)
- (1) CAST UV Black 11" Cable Ties, pkg of 100 (CTIES)
- (1) 500 Ft. Roll CAST #16/2 No-Ox Wire (PLW162500)
- (1) 1/4" ID Supplied (5/64" Recovered) Heat Shrink with Internal Sealant 100 ft. 2' pieces (CHS14100)
- (1) Wire Quick Connect Cable Gland Separation Tool (C1098)
- (1) Wire Crimping Tool #10 & Cutter (CCRIMP CUT)
- (2) End Wire Crimp Caps (XCEW30648)

Notes:

1. Attach wire directly to inside of horizontal fence pipe at 7 o'clock orientation. Use cable ties every 18 inches.
2. Attach wire to +/- blue terminal block 30V DC 60 Watt tap.
3. Make sure terminal block connection is tight.
4. PoE power supply requires network switch that delivers 60 Watts or better power to the CPOE60W. Commonly referred to as a PoE++ switch.