

### Description

Talkaphone's **Wireless Blue Light Phone Tower** is an ADA-compliant, outdoor-rated tower for off-grid remote areas. An ideal solution for locations where cable trenching is not feasible or where there is minimal infrastructure.

This robust emergency communication solution offers a reduced ecological footprint by combining an ETP-520 Series Call Station and an ETP-MTE-WP ECO TOWER® with the latest in cellular and solar technology.

### Features

- Solar-powered and autonomous
- Includes two (2) years of cloud monitoring and email alerting for:
  - Change in cellular connection (i.e. offline/online)
  - SIM card removal/insertion
- Cellular connectivity—operates on the AT&T, T-Mobile, or Verizon networks
- Single nano-SIM (4FF) card slot
- Hands-free two-way communication
- ADA-compliant
  - Raised letter and braille signage
  - Two (2) LED indicators for hearing impaired (CALLING and ANSWERED)
- Place call by activating push button
- Vandal resistant 316 marine grade stainless steel faceplate
- Call Station is illuminated at all times by an LED Panel Light
- Built-in auto-dialer can dial up to five (5) numbers. If first number does not answer or is busy, dials second number. If second number does not answer or is busy, dials third number—and so on.
- Ability to playback a pre-recorded message with location information at the beginning of a call
- Inbound calls are auto-answered—allowing for remote audio monitoring



### Specifications

Construction:	<b>Call Station:</b> 0.086 in. (2.13mm) #4 brushed 316 stainless steel faceplate
	<b>Tower:</b> 0.125 in. aluminum
Weight:	167.0 lbs. (75.7 kg)
Tower Coating:	High-gloss, multi-layer, corrosion-inhibitive system with resistance to UV-fade and graffiti protection
Lighting:	<b>LED Blue Light:</b> 209 lumens peak, 78 flashes per minute, 50,000 hour lifetime
	<b>LED Panel Light:</b> Ultra-bright LEDs, 50,000 hour lifetime
Mounting:	Mounts onto concrete foundation using included J-bolt hardware (shipped in advance)
Storage Temperature:	-40° F to +149° F (-40° C to +65° C)
Operating Temperature:	-22° F to +131° F (-30° C to +55° C)
Relative Humidity:	Up to 95% non-condensing
Ingress Protection:	<b>Call Station:</b> IP66
	<b>Tower:</b> IP55, NEMA 3R

#### IMPORTANT NOTES:

- (1) Cellular Gateway **does not currently support E911 and cannot dial 911.**
- (2) All programming, diagnostics, and identification of the ETP-520 Series Analog Call Station are accomplished through the transmitting and receiving of in-band DTMF signals. Cellular transmissions and cellular networks may interfere with and distort these tones. As a result of these irregularities, operation of the ETP-520 Series Analog Call Station may not function as intended on a cellular network.

# Wireless Blue Light Phone Tower

## Specifications (Continued)

Power:	100W solar panel (photovoltaic module) for lower region, 140W for upper region 84Ah battery capacity (2x 42Ah batteries)
Colors:	Blue and Red are standard. Available in custom colors.
Signage:	3.25 in. high reflective white “EMERGENCY” lettering with wide-angle visibility is standard. Available in custom colors, lettering, and graphics.
Circuit Protection:	Conformal coated circuit board
Communication:	Half duplex two-way hands-free communication
Programming:	<b>Call Station:</b> Non-volatile EEPROM programming can be done from a remote telephone. No battery backup is needed to save configuration.
Digit Capacity:	Up to 50-digits, including pauses, for each of five (5) phone numbers
SIM Card:	Nano-SIM (4FF)
4G LTE Bands:	B2, B4, B5, B12, B13, B14, B66, B71
Compliance:	FCC Part 15, Subpart B, Class A FCC 47 CFR Part 68 UL Standards 60950-1 and 60950-22
Approvals:	<b>Cellular</b> FCC Part 15b <b>Gateway:</b> PTCRB RoHS <b>Tower:</b> ETL Recognized Component—Conforms to UL Standards 60950-1 and 60950-22. Certified to CSA Standard C22.2 Nos. 60950-1 and 60950-22.
Limited Warranty:	<b>Electronics:</b> 2-year limited warranty <b>Tower:</b> 5-year limited warranty

### IMPORTANT NOTES:

- (1) Cellular Gateway **does not currently support E911 and cannot dial 911.**
- (2) All programming, diagnostics, and identification of the ETP-520 Series Analog Call Station are accomplished through the transmitting and receiving of in-band DTMF signals. Cellular transmissions and cellular networks may interfere with and distort these tones. As a result of these irregularities, operation of the ETP-520 Series Analog Call Station may not function as intended on a cellular network.

# Wireless Blue Light Phone Tower

## Ordering Information

	Model Series	Tower Color	Geographic Region (see map)	Call Station Interface	Carrier Network
	<b>BLPT-SOLAR</b>	<b>[Leave Blank]</b> Blue tower finish  <b>-RD</b> Red tower finish	<b>-L</b> For installations in the areas marked in gray  <b>-U</b> For installations in the areas marked in red	<b>-E</b> Red push button labeled EMERGENCY  <b>-C</b> Red push button labeled CALL  <b>-EC</b> Red push button labeled EMERGENCY and black push button labeled CALL  <b>-EI</b> Red push button labeled EMERGENCY and black push button labeled INFO	<b>-A</b> For use with AT&T network Voice over LTE (VoLTE) plans
Example #1	BLPT-SOLAR		-U	-E	-A
Example #2	BLPT-SOLAR	-RD	-L	-EC	-A

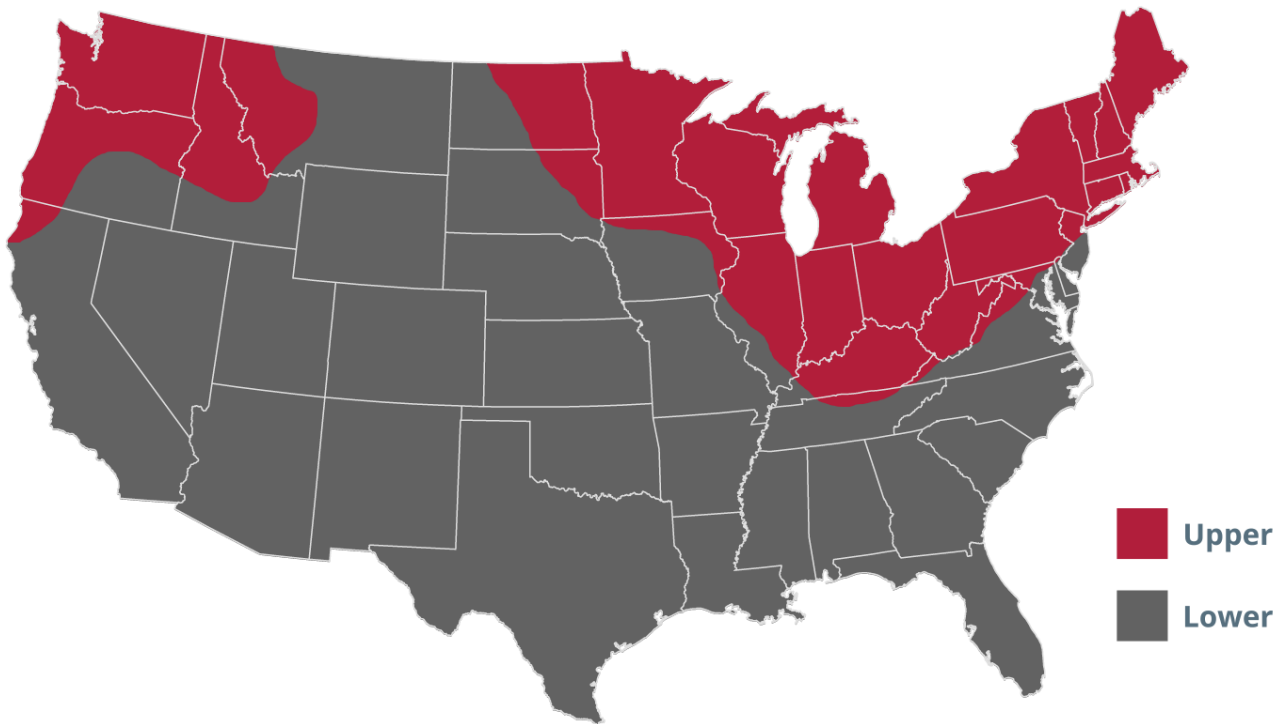

**Note:** Systems are designed for up to five (5) days of autonomy for first-party equipment only and are based on historical solar insolation data. Performance of the system will depend on actual cloud coverage and solar insolation and may vary. For options to support third-party equipment, please contact Talkaphone Sales.

# Wireless Blue Light Phone Tower

## Options

### Prepaid SIM Cards:

Available prepaid Voice over LTE (VoLTE) SIM cards for AT&T networks. Includes one (1) SIM card and 100 minutes per month. Contact for further details.<sup>1</sup>

Order model **SRVC-CGW-4G-V2-ATT-1Y** for a 1-year prepaid SIM card.

Order model **SRVC-CGW-4G-V2-ATT-2Y** for a 2-year prepaid SIM card.

### Cloud Monitoring and: Maintenance Plans

Initial hardware purchase includes two (2) years of cloud monitoring, email alerting, and firmware updates.

Order model **MAINT-CGW-4G-V2-1Y** for an additional one (1) year.

Order model **MAINT-CGW-4G-V2-2Y** for an additional two (2) years.

### IMPORTANT NOTES:

<sup>1</sup> Service does not currently support E911 and cannot dial 911.

## Dimensional Diagram

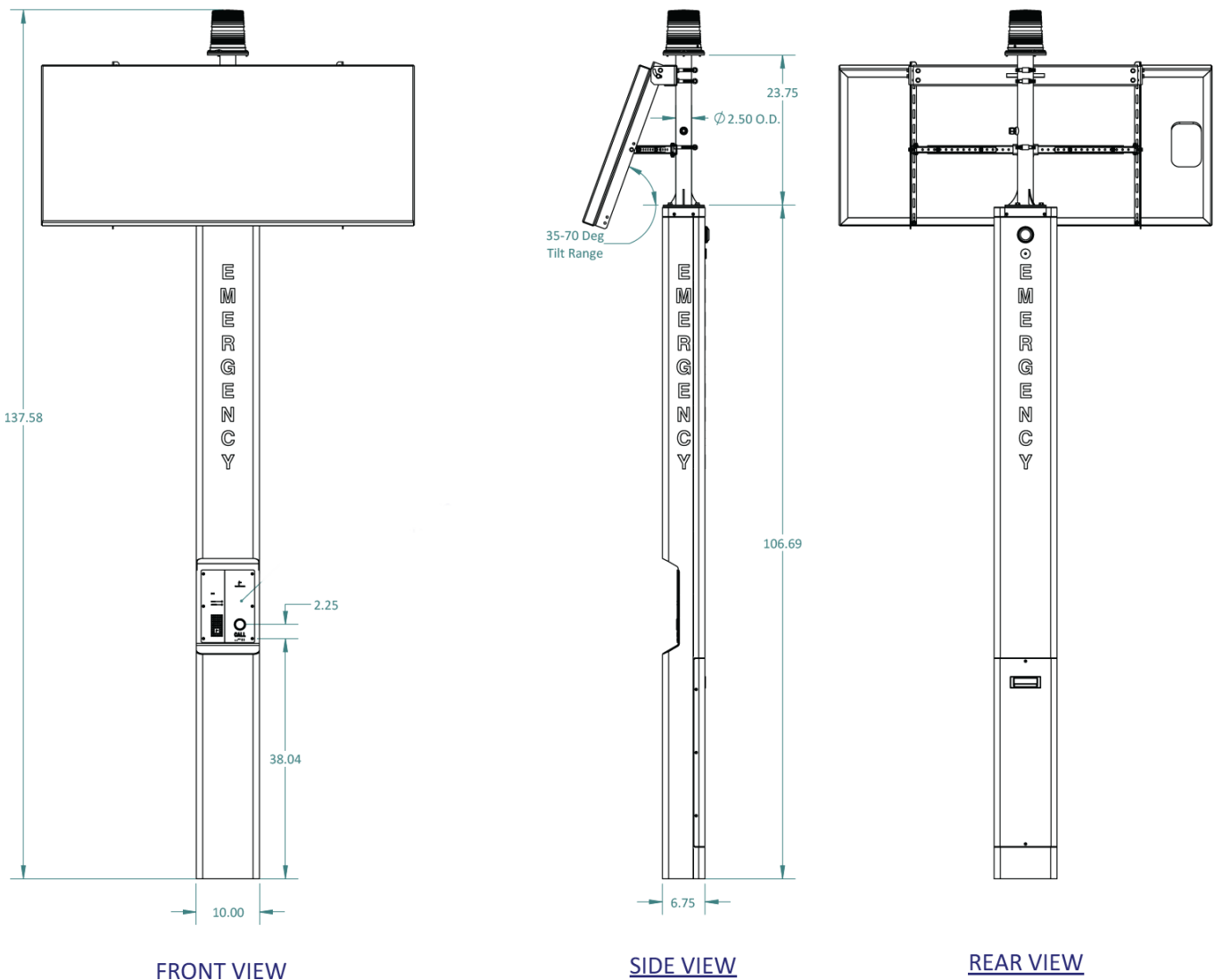

All dimensions are in inches and are provided for reference only.