

## Patch and Splice Fiber Terminal Enclosure

The HyperDrop™ PAS Compact provides a compact, versatile, and functional solution for FTTH network connections. It features a main fiber feed express port and 8 branch ports. These cost-effective closures are fully sealed units which can be used in any network topology. They are particularly useful for installing in a small hand hole. There is one 24-fiber splice tray included that includes either a 1x8 PLC splitter or 3-meter long pigtail.



## KEY FEATURES

- Robust GF-PP housing to withstand acidic and alkaline environments
- Mechanical compression technology provides cost-effective, reliable sealing
- Sealed IP68 rated and can be used both aerially and below grade
- 8 drop ports can accommodate flat or round drop cables
- 24 splice capacity
- 1x8 PLC splitter or 3-meter long pigtail options
- Aerial installation kit is included

## TECHNICAL SPECIFICATIONS

- **WEIGHT:** 1.5 kg (3.31 lb)
- **DIMENSIONS:** 257 x 168 x 88 mm (10.12 x 6.61 x 3.46 in)
- **MATERIAL:** Glass-filled polypropylene (GF-PP)
- **COLOR:** Black
- **FEED CABLE COMPATIBILITY:** 10 to 17.5 mm dia
- **TEMPERATURE RANGE:** -40°C to 65°C (-40°F to 149°F)
- **ENVIRONMENTAL RATING:** IP68
- **COMPLIANCY:** RoHS
- **COUNTRY OF ORIGIN:** China
- **INCLUDED ACCESSORIES:** 8 simplex SC/APC adaptors, 8 flat-drop grommets, 8 large grommets (6-7mm cable), 8 medium grommets (4.5-6mm cable), 8 small grommets (3-4 mm cable), 8 plastic nuts, aerial installation kit

## ORDERING INFORMATION

Part Number	Description
HDPAS-SA1-S8	HyperDrop PAS™ Compact (Patch and Splice) with 1x8 splitter
HDPAS-SA1-P8	HyperDrop PAS™ Compact (Patch and Splice) with 3-meter long pigtail

## IMAGES



Cable Port View



Open Splice Tray

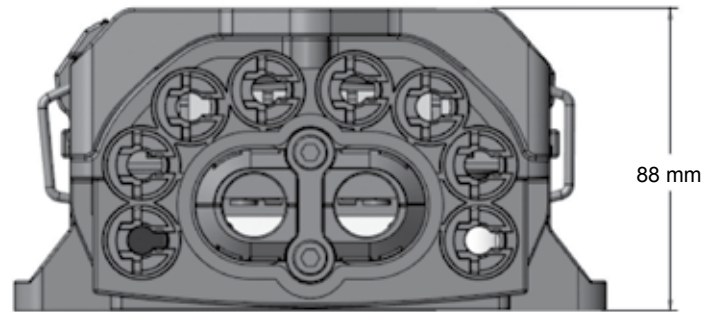
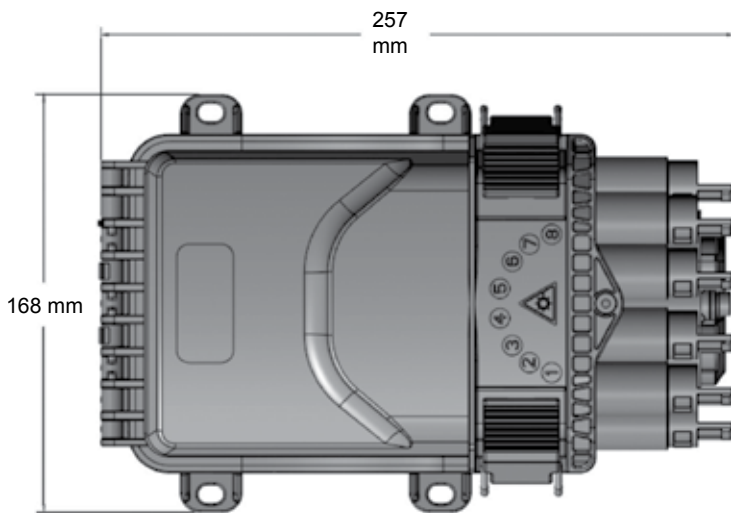

Dimensional Drawing