



**Safety Technology  
International**

## **UB-1PN Universal Pneumatic Button**



**ADA  
Compliant**

**We protect the things that protect you.®**

## NOTES

It is important to read, understand and follow all instructions provided with this product. It is the installer's responsibility to comply with NFPA 70 & 101, NEC, mounting specifications according to ADA and other applicable electrical codes. To avoid electrical shock, DO NOT attempt to install this product when power is on. ADA mounting compliance requires the operable part of the initiating device shall not be less than 3 1/2 ft. (1.1m ) or greater than 4 1/2 ft. (1.37m) above finished floor surface. After installation and testing are complete, provide a copy of this manual to all personnel responsible for testing and maintenance of this product.

\* For access control installations, power for the UB-1PN must be supplied by a power source Listed to UL294. When used for access control, this device shall be used as a part of an access controlled egress door system. It is up to the local AHJ to allow use of this device in place of an automatic sensor. For higher security installations, lower time limits should be used.

UB-1PN: UL Recognized component UL508, indoor use only.

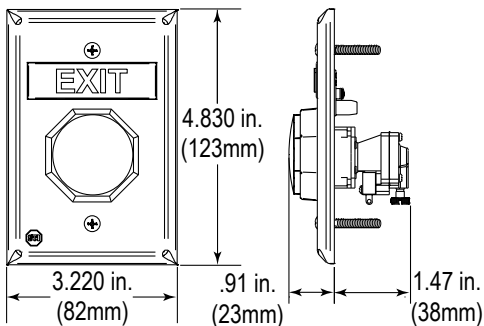

## SWITCH RATING

Independent Form "Z" contacts

Rated at: 10A @ 240 VAC

Operating Temp: 15° to 120°F (-9° to 49°C)

1,000,000 Cycles

## 1. TO CHANGE BUTTON COLOR AND ROUND MESSAGE

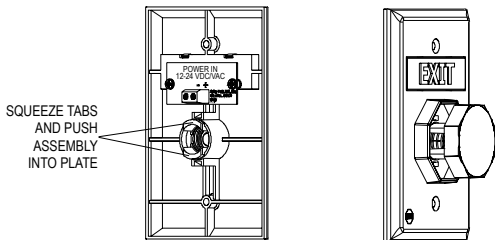

1. Choose button message and color. If same as existing, proceed to 2.
2. If choosing a new message, remove button. On the back side of the plate, squeeze tabs and push actuator assembly into plate just enough to grasp the button and remove.
3. From the front of the plate, push actuator back into original position.
4. Choose button message. Blank plate is available for your custom message.
  - a. Insert button message, align 4 notches on actuator.
  - b. Select color lens. Align top and bottom notches with tabs on actuator and push until it snaps together.

## 2. CHANGE TOP MESSAGE

1. Remove LED circuit board.
2. Remove current message by pushing in and down on tabs 1 and 2 with a small screwdriver. If necessary, also push in and down on tabs 3 and 4. Once message is loose, remove from the front of the plate.
3. Select new message and snap into place. Blank plates are included to create your own custom message.

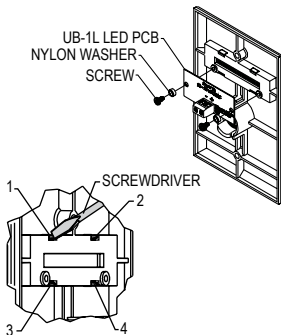

### 3. INSTALL OR REMOVE CONTACT BLOCK

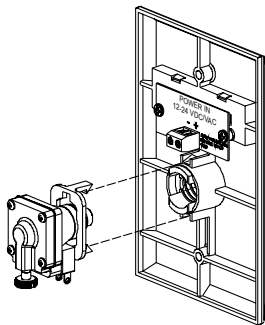

CONTACT INFORMATION

#### INSTALL

To attach, align tabs (as shown) and gently snap **top, then bottom**.

Be sure to hear **BOTH** tabs snap into place.

Contacts can be rotated 180° if desired.

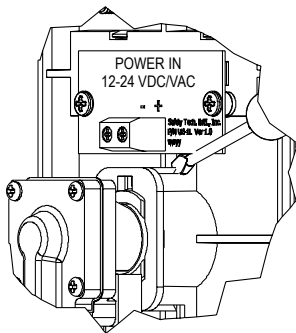
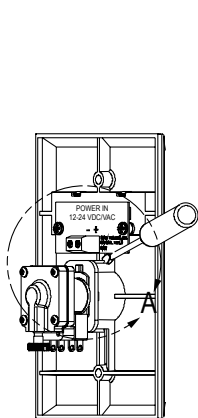

CONTACT REMOVAL  
DETAIL A

#### REMOVE

To remove, use a small flat blade screwdriver.

Position screwdriver blade under tab and gently rotate screwdriver until tab disengages. Repeat for opposite tab.

#### 4. ATTACH POWER FOR LED (if desired)

(See drawing)

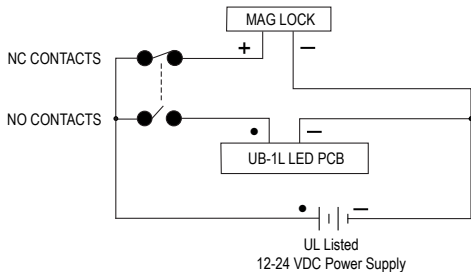

	<u>NORMAL POSITION</u>	<u>BUTTON ACTIVATED</u>
MAGNETIC LOCK	ON	OFF
MESSAGE LAMP	OFF	ON

#### CONTACT DIAGRAM

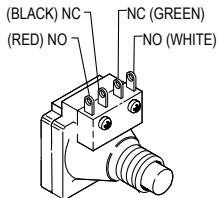

#### CONTACTS

One set NO and one set NC

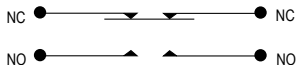

## SWITCH INFORMATION

**TIMER RANGE ADJUSTMENT SCREW**  
ADJUSTMENT RANGE 4 TO 60 SECONDS ( $\pm 15\%$ )  
WITH REPEAT ACCURACY  $\pm 10\%$

TIMER FACTORY SET TO MINIMUM TIME  
SETTING. TO INCREASE TIME, TURN  
SCREW CLOCKWISE IN 1/4 TURN  
INCREMENTS. WHEN CLOSE TO DESIRED  
TIME, TURN SCREW IN VERY FINE  
INCREMENTS TO DESIRED SETTING.

**CAUTION:** OVER-TIGHTENING MAY  
CAUSE DAMAGE TO TIMER.

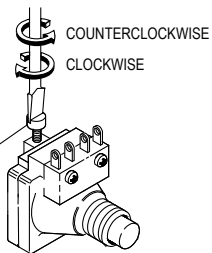

## 5. MOUNT BUTTON ONTO ELECTRICAL BOX

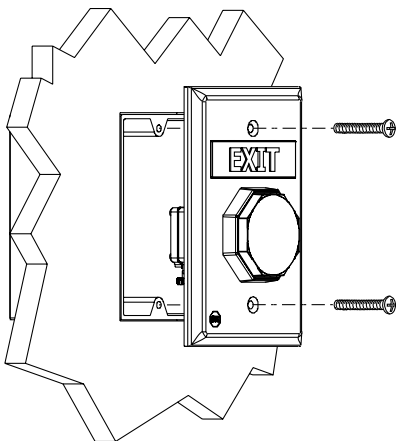

## 6. CUSTOM LABELS

To create your own custom label, size to fit in .48h x 2.23w as shown below.

Also available online at: [www.sti-usa.com/ublabel](http://www.sti-usa.com/ublabel)

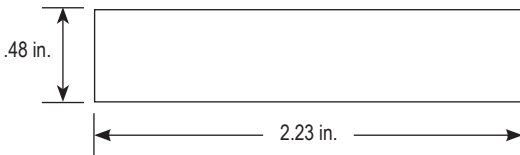

### ACCESSORIES

DESCRIPTION	PART #
COLOR MATCH BACK BOX KIT	KIT-71100A-*
	* (R=Red, B=Blue, G=Green, W=White Or Y=Yellow)
CUSTOM LABEL APPLIED TO BLANK MESSAGE PLATES	UB-1CL-*
	* (B=Blue, G=Green, W=White Or Y=Yellow)
BUTTON REPLACEMENT LENSES: (red, green & blue)	UB-1LENS
2" LENS KIT FOR UNIVERSAL BUTTON	UB-2LENS
<u>COVERS</u>	
BOPPER STOPPER	STI-6518
UNIVERSAL STOPPER	STI-13000 Series
STOPPER II®	STI-1100 Series
– See website for complete cover details –	

## Warranty

Three year guarantee against breakage of polycarbonate in normal use (one year on electro mechanical and electronic components). Electronic warranty form at [www.sti-usa.com/wc14](http://www.sti-usa.com/wc14).

**⚠ WARNING:** This product can expose you to chemicals including Dichloromethane, which is known to the State of California to cause cancer, and Bisphenol A (BPA), which is known to the State of California to cause birth defects or other reproductive harm. For more information go to [www.P65Warnings.ca.gov](http://www.P65Warnings.ca.gov).



USA



**Safety Technology  
International**



EMEA

2306 Airport Rd • Waterford, MI 48327, USA

Phone: 248-673-9898 • [info@sti-usa.com](mailto:info@sti-usa.com) • [www.sti-global.com](http://www.sti-global.com)

Taylor House • 34 Sherwood Road • Bromsgrove, Worcestershire • B60 3DR • England

Tel: +44 (0)1527 520 999 • [info@sti-emea.com](mailto:info@sti-emea.com) • [www.sti-global.com](http://www.sti-global.com)

Unit 7A • Lockhead Avenue • Airport Business Park • Waterford • X91 HWF2 • Ireland

[info@sti-emea.com](mailto:info@sti-emea.com) • [www.sti-global.com](http://www.sti-global.com)