



SISTG10xx-211-LRT-B series Hardened Unmanaged Gigabit Ethernet Media Converter



SISTG1013-211-LRT-B

SISTG1040-211-LRT-B

SISTG1014-211-LRT-B

Install Guide

33749 Rev. C

Trademarks

All trademarks and registered trademarks are the property of their respective owners.

Copyright Notice/Restrictions

Copyright© 2018-2021 Transition Networks. All rights reserved. No part of this work may be reproduced or used in any form or by any means (graphic, electronic or mechanical) without written permission from Transition Networks. Printed in the U.S.A.

SISTG10xx-211-LRT-B series Hardened Unmanaged Gigabit Ethernet Media Converter Install Guide

Contact Information

Transition Networks

10900 Red Circle Drive

Minnetonka, MN 55343 USA

tel: +1.952.941.7600 | toll free: 1.800.526.9267 | fax: 952.941.2322

sales@transition.com | techsupport@transition.com | customerservice@transition.com

Revision History

Rev.	Date	Description
A	6/25/18	Initial release at v1.0.
B	2/17/20	Change Device label to reflect UL C1D2 Temperature code change; add Power Connect/Disconnect information.
C	7/28/21	Update Safety certification from EN60950 or IEC60950 to IEC62368-1/EN62368-1. Update DoC.

Cautions and Warnings

Definitions

Cautions indicate that there is the possibility of poor equipment performance or potential damage to the equipment. **Warnings** indicate that there is the possibility of injury to person.

Cautions and Warnings appear here and may appear throughout this manual where appropriate. Failure to read and understand the information identified by this symbol could result in poor equipment performance, damage to the equipment, or injury to persons.

Cautions



While installing or servicing the power module, wear a grounding device and observe all electrostatic discharge precautions. Failure to observe this caution could result in damage to, or failure of the power module.

Warnings



Warning: Do not connect the power module to an external power source before installing it into the chassis. Failure to observe this warning could result in an electrical shock, even death.

WARNING: Equipment grounding is vital to ensure safe operation. The installer must ensure that the power module is properly grounded during and after installation. Failure to observe this warning could result in an electric shock, even death.

WARNING: A readily accessible, suitable National Electrical Code (NEC) or local electrical code approved disconnect device and branch-circuit protector must be part of the building's installed wiring to accommodate permanently connected equipment. Failure to observe this warning could result in an electric shock, even death.

WARNING: Turn any external power source OFF and ensure that the power module is disconnected from the external power source before performing any maintenance. Failure to observe this warning could result in an electrical shock, even death.

WARNING: Ensure that the disconnect device for the external power source is OPEN (*turned OFF*) before disconnecting or connecting the power leads to the power module. Failure to observe this warning could result in an electric shock, even death.

See [Electrical Safety Warnings](#) on page 32 for Electrical Safety Warnings translated into multiple languages.

Table of Contents

Overview	6
Features	6
Specifications	6
Port Configuration.....	7
Optional Accessories (sold separately)	7
Hardware Performance.....	7
Environmental Range.....	7
Dimensions, Weight, Mounting	7
Voltage and Frequency	7
Compliance.....	8
MTBF	8
DC Power Consumption	9
Dimension Drawings	10
SISTG1040-211-LRT-B and SISTG1014-211-LRT-B Dimensions	10
SISTG1013-211-LRT-B Dimensions	11
Feature Comparison.....	12
Advanced Feature Descriptions	14
AutoCross	14
Auto-Negotiation	14
Remote Loopback	14
Link Fault Pass-through (LFP)	15
Copper (RJ-45) Cable Specifications.....	16
Fiber Cable and Optic Specifications.....	17
Fiber Cable Characteristics.....	17
Power Supply Features and Specifications	17
25135 Industrial Power Supply Optional Accessory	17
SPS-UA12DHT Industrial Power Supply Optional Accessory.....	17
About This Manual	18
Related Manuals	18
Installation	19
Installation Overview	19
Package Contents.....	19
Unpacking	19
Front Panel.....	20
Back Panel	20
Top Panel.....	21
RESET Button.....	21
DIP Switch for Feature Selection.....	22
DIN Rail Mounting.....	23
Installing SFP Modules	24
Connecting to Network / Devices	25
Connecting Fiber Cables.....	25
Connecting Copper Cables	26
Copper Cable Configuration.....	26
Ground Screw - Grounding the Media Converter.....	27
Connecting Power to the Media Converter	28
Terminal Block Wiring.....	29

- Power Cord.....30
- Power Supply - Optional Accessories (sold separately)30
- LEDs.....31
- Troubleshooting.....32
 - Basic Troubleshooting.....32
 - LED Troubleshooting.....32
 - Device Label and Box Label.....33
 - Record Device and System Information35
- Regulatory and Safety Information.....36
 - Compliance and Safety Statements36
 - Cautions and Warnings36
 - Declaration of Conformity37
 - High Risk Activities Disclaimer37
 - Electrical Safety Warnings.....38
- Service, Warranty and Tech Support39
 - Warranty39
 - Five-Year Limited Hardware Warranty39
 - Contact Us.....40

Overview

The Transition Networks SISTG10xx-211-LRT-B Series is a new generation of unmanaged hardened Gigabit Ethernet media converter. The converter can provide multimode or single mode fiber connections with fixed SC connectors for extending the Ethernet service distance over fiber. The converter also has a SFP version that provides the ultimate flexibility to choose the appropriate SFP module to match your communication and distance needs.

It has redundant input power connections to ensure safe reliable operation in temperatures between -40°C and +75°C. Transition Networks' hardened switches are certified with UL Class 1 Division 2 to operate reliably in hazardous locations such as Oil & Gas, manufacturing, and the chemical industry.

Features

The SISTG10xx-211-LRT-B is a hardened Media Converter that provides:

- Auto-Negotiation
- Auto-MDI/MDIX
- Link Fault Pass-through
- Extended operating temperature (-40°C to +75°C)
- Dual, Redundant, 12-48 VDC Power Inputs
- Reverse Polarity Power Input Protection
- Overload Current Protection
- DIN Rail Mounting Brackets Included
- Class 1, Div 2 Certified
- Jumbo Frame: 9K bytes

Ordering Information

Model	Description
SISTG1013-211-LRT-B	10/100/1000Base-T (RJ-45) [100 m/328 ft.] to 1000Base-SX 850nm multimode (SC) [62.5/125 μm: 220 m/722 ft.] [50/125μm: 550 m/1804 ft.] Link Budget: 8.5 dB
SISTG1014-211-LRT-B	10/100/1000Base-T (RJ-45) [100 m/328 ft.] to 1000Base-LX 1310nm single mode (SC) [9/125μm: 10 km/6.2 mi.] Link Budget: 10.5 dB
SISTG1040-211-LRT-B	10/100/1000Base-T (RJ-45) [100 m/328 ft.] to 100/1000Base-X SFP slot (empty)

Specifications

Port Configuration

Model Name	Total Ports	RJ45 (10M/100M/1G)	Fiber (100M/1G)
SISTG1013-211-LRT-B	2	1	1 (1G SC MM)
SISTG1014-211-LRT-B	2	1	1 (1G SC SM 20Km)
SISTG1040-211-LRT-B	2	1	1 (100M/1G SFP)

Optional Accessories (sold separately)

Options (sold separately)	
25135	Optional Industrial Power Supply Optional Accessory (sold separately). Input: 85 -264VDC, 120-370VDC. Output: 24VDC, 10Watts, -20°C to +70°C.
SPS-UA12DHT	External power supply includes: (1) AC/DC power supply, 100-240VAC input, 50-60Hz, 12VDC, 1.5A output, 0°C to +70°C operating temp. (1) Regional specific power cord.
SFP Modules	Transition Networks offers a full line of small form factor pluggable (SFP) transceivers. See our Optical Devices webpage for details. See the SFP manual for cautions and warnings.

Hardware Performance

Forwarding Capacity (Mpps)	Switching Capacity (Gbps)	Mac Table (K)	Jumbo Frames (Bytes)
2.976	4	4	9216

Environmental Range

Operating Temperature		Storage Temperature		Operating Humidity	Altitude	
Fahrenheit	Centigrade	Fahrenheit	Centigrade		Feet	Meters
-40 to +167	-40 to +75	-40 to +185	-40 to +85	5% to 95% non-condensing	< 10000	<3000

Dimensions, Weight, Mounting

Dimensions (WxHxD)		Weight		Mounting Type
Millimeters	Inches	Kilograms	Pounds	
110x 30x 98	4.33x 1.18x 3.85	0.97 kg.	0.44lbs.	DIN Rail

Voltage and Frequency

Primary Power Supply - DC Input Voltage	
DC Input Power	Input: 12V~48V DC dual inputs with terminal block.

Compliance

Regulatory Compliance	
Regulatory Agency Compliance	UL Class 1, Div 2 for hazardous environments. CISPR/EN55022 Class A, FCC Class A, CE Mark, EN61000-4-2, EN61000-4-3, EN61000-4-4, EN61000-4-5, EN61000-4-6, IEC60068-2-32 (Free fall), IEC60068-2-27 (Shock), IEC60068-2-6 (Vibration)

MTBF

Model	MTBF	Environment
SISTG1013-211-LRT-B and SISTG1014-211-LRT-B	1,639,500 Hrs.	GB, GC - Ground Benign, Controlled. Temp: 25.00° C.
	251,499 Hrs.	GB, GC - Ground Benign, Controlled. Temp: 75.00° C.
SISTG1040-211-LRT-B	1,628,265 Hrs.	GB, GC - Ground Benign, Controlled. Temp: 25.00° C.
	248,741 Hrs.	GB, GC - Ground Benign, Controlled. Temp: 75.00° C.

DC Power Consumption

Measured DC power consumption after 60 minutes under full loading with wire speed forwarding.

12 VDC Input

Status	Operation Interface	DC Current Consumption (A)	DC Voltage (V)	DC Power Consumption (W)
Non-loading	None	0.10	12	1.20
Standby mode	1G RJ45 Port x 1 1G Fiber Port x 1	0.17	12	2.04
Full-loading 60 minutes later	1G RJ45 Port x 1 1G Fiber Port x 1	0.18	12	2.16

24 VDC Input

Status	Operation Interface	DC Current Consumption (A)	DC Voltage (V)	DC Power Consumption (W)
Non-loading	None	0.05	24	1.20
Standby mode	1G RJ45 Port x 1 1G Fiber Port x 1	0.10	24	2.40
Full-loading 60 minutes later	1G RJ45 Port x 1 1G Fiber Port x 1	0.10	24	2.40

48 VDC Input

Status	Operation Interface	DC Current Consumption (A)	DC Voltage (V)	DC Power Consumption (W)
Non-loading	None	0.05	48	2.40
Standby mode	1G RJ45 Port x 1 1G Fiber Port x 1	0.07	48	3.36
Full-loading 60 minutes later	1G RJ45 Port x 1 1G Fiber Port x 1	0.07	48	3.36

Dimension Drawings

SISTG1040-211-LRT-B and SISTG1014-211-LRT-B Dimensions

Dimensions shown are in millimeters (mm).

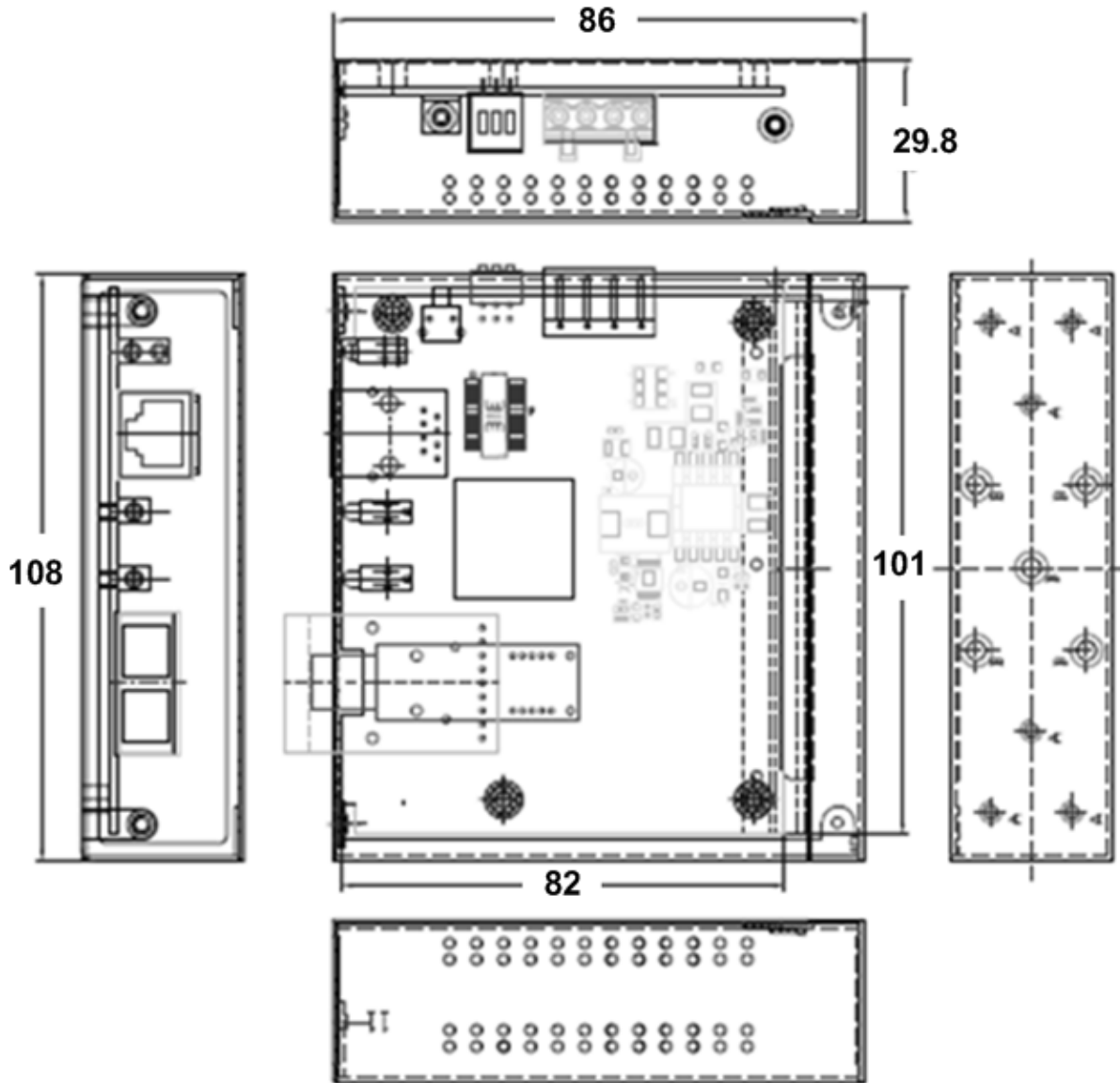

SISTG1013-211-LRT-B Dimensions

Dimensions shown are in millimeters (mm).

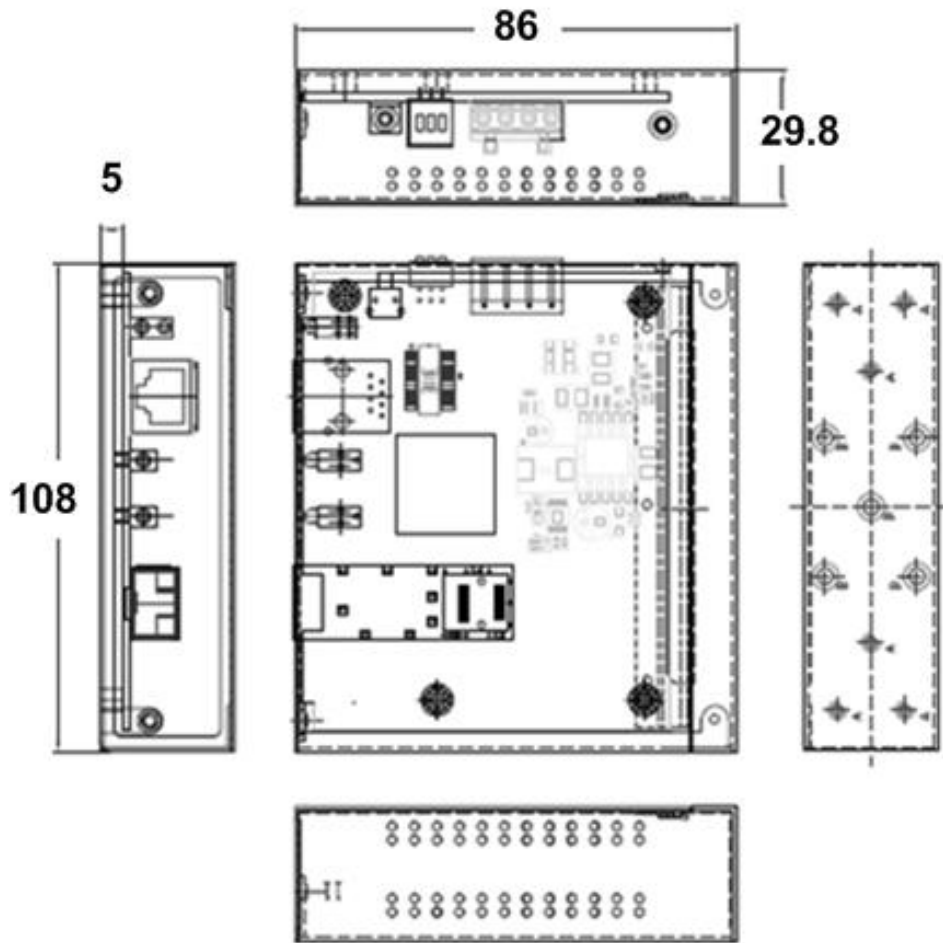

Feature Comparison

The SISTG10xx-211-LRT (EOL) and SISTG10xx-211-LRT-B features are compared below.

Feature	SISTG10xx-211-LRT	SISTG10xx-211-LRT-B
Port Configuration	One 10/100/1000Base-T RJ-45 to one 1000Base-SX/LX or 1000Base-X SFP	One 10/100/1000Base-T RJ-45 port to one 1000Base-SX/LX or 100/1000Base-X SFP
Jumbo Frame	9K	9K
Power Supply Options	SPS-UA12DHT, 25083	SPS-UA12DHT, 25135
Auto-Negotiation	Yes	Yes
Auto-MDI/MDIX	Yes	Yes
Link Fault Pass-through	Yes (LFP)	Yes (LFP)
Flow Control	Yes; IEEE 802.3x flow control support; Flow control on FDX, Back pressure on HDX	No
Pause	Yes, IEEE 802.3xy	No
Remote Loopback	No	Yes
DIN Rail Mounting	Yes	Yes
Wall Mount Brackets	Yes	No
Dry Contact Relay	Yes	No
Alarm Output	Yes	No
Redundant DC Power Inputs	Yes	Yes
Dual Auto-Sensing	Yes	No
Automatic failover		Yes
Media Converter Mode or Switch Converter Mode	Yes	No
Barrel connector I/F cable included	Yes	No
Extended operating temperature	-40°C to +75°C	-40°C to +75°C
Reverse Polarity Protection	Yes	Yes
Overload Current Protection	Yes	Yes
Class 1, Div 2 Certified	Yes	Yes

Feature	SISTG10xx-211-LRT	SISTG10xx-211-LRT-B
DIP Switch Options	1: Enable/Disable Port Alarms. 2: Enable/Disable Link Pass Through. 3: Full/Half-Duplex 100Base-FX. 4: Converter/Switch Mode.	1: SFP - Enable Auto Negotiation for the SFP / Force Gigabit speed for SFP port. 2: Copper - Enable Auto Negotiation for the copper / Force Gigabit speed for copper. 3: LPT - Enable/Disable Link Fault Pass-through.
Require Power Cycle for DIP Switch settings	Yes	No
LEDs	PWR1, PWR2, FAULT, LNK/ACT (Fiber port), 1000M, LNK/ACT (RJ45 port).	PWR 1, PWR 2, RJ45 Port Link/ACT, and Fiber Port Link/ACT.
Dimensions	Width: 1.2" [30 mm] x Depth: 3.7" [95 mm] x Height: 5.5" [140 mm]	WxHxD: 6.22x 1.57x 5.23 Inches. 158x 40x 133 Millimeters.
Power Consumption	3.36 Watts	3.4 Watts (max)
Power Input	12 to 48 VDC, 0.2A-0.7A	12 to 48 VDC, 0.2A-0.5A
Fault Output	Relay output contacts, 1A@24VDC load capacity	None
Ingress Protection	IP30	IP30
Environment	Storage Temp: -40°C to 85°C Humidity: 5% to 95% (non-condensing) Altitude: 0 – 10,000 ft.	Storage Temp: -40 to +185° F; -40 to +85° C. Oper. Humidity: 5% to 95% non-condensing. Altitude: < 10000 Feet. <3000 Meters.
Weight	1.4 lbs. [0.63 kg]	0.97 lbs. [0.44kg]
Warranty	Lifetime Limited	5 Year
Compliance	Safety: UL508, CSA C22.2. IEC62368-1/EN62368-1. UL Class 1, Div 2 for hazardous environments, cUL CISPR/EN55022 Class A, FCC Class A, CE Mark, EN61000-4-2, EN61000-4-3, EN61000-4-4, EN61000-4-5, EN61000-4-6, IEC60068-2-32 (Free fall) IEC60068-2-27 (Shock), IEC60068-2-6 (Vibration)	UL Class 1, Div 2 for hazardous environments. CISPR/EN55022 Class A, FCC Class A, CE Mark, EN61000-4-2, EN61000-4-3, EN61000-4-4, EN61000-4-5, EN61000-4-6, IEC60068-2-32 (Free fall), IEC60068-2-27 (Shock), IEC60068-2-6 (Vibration)
MTBF	SISTG1014-211-LRT: 252,300 hours	SISTG1013-211-1013-LRT-B / SISTG1014-LRT-B: 1,639,500 Hrs. @ 25.00° C; 251,499 Hrs. 75.00° C. SISTG1013-211-1040-LRT-B: 1,628,265 Hrs. @ 25.00° C; 248,741 Hrs. @ 75.00° C.

Advanced Feature Descriptions

This section describes advanced features including AutoCross, Auto-Negotiation, Link Fault Pass-through and Remote Loopback.

AutoCross

AutoCross automatically detects and configures the twisted pair port on the converter to the correct MDI or MDI-X configuration allowing either straight-through (MDI) or crossover (MDI-X) cables to be used – see below. No user intervention is required. Benefits include:

- Eliminates an entire category of troubleshooting
- No need to identify cable type; straight-through or crossover
- No user intervention required to determine correct button / switch settings

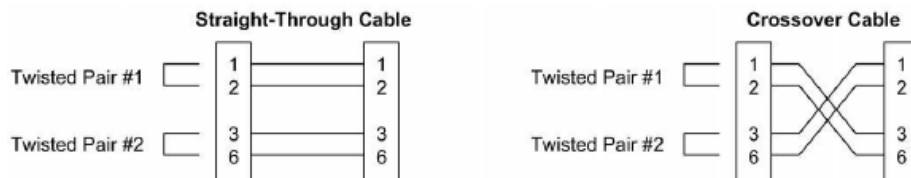

Auto-Negotiation

Auto-Negotiation allows devices to perform automatic configuration to achieve the best possible mode of operation over a link. The Media Converter will broadcast its speed (10 Mbps, 100 Mbps, 1000 Mbps) and duplex (half/full) capabilities to other devices and negotiate the best mode of operation between the two devices.

- No user intervention required to determine best mode of operation
- Optimal link established automatically
- Quick and easy installation

Note: If the Media Converter is connected to a non-negotiating device over the copper link, it will default to 10 Mbps speed, half duplex mode. See “[DIP Switch for Feature Selection](#)” on page 22.

Remote Loopback

The loopback test uses a method which feeds a received signal or data back to the sender. It can be used to debug physical connection problems. As a test, many data comm devices can be configured to send a specific pattern on an interface and then detect the reception of this signal on the same port. See “[DIP Switch for Feature Selection](#)” on page 22.

Link Fault Pass-through (LFP)

The SISTG10xx-211-LRT-B supports Link Fault Pass-through, with no need for a specific link partner.

Link Fault Pass-through is a troubleshooting feature that allows the media converter to monitor both the fiber and copper RX ports for loss of signal. In the event of a loss of RX signal on one media port, the converter will automatically disable the TX signal of the other media port, thus "passing through" the link loss.

- End device automatically notified of link loss
- Prevents loss of valuable data unknowingly transmitted over invalid link

Note: Once the fault condition is resolved, the LNK/ACT LED will blink for 2 ~ 6 seconds while the connection is recovering from the failure. See “DIP Switch for Feature Selection” on page 22.

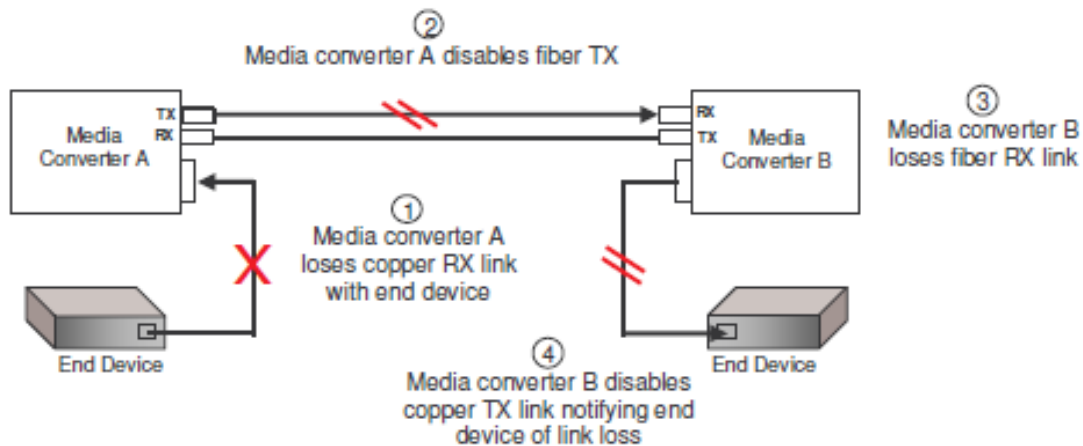

Link Fault Pass-through causes loss of link on one side of a media converter to be passed through to the other side, so that upstream equipment can see fault conditions that would otherwise be hidden by the media converters.

On some models, the Link Fault Pass-through logic views receipt of a Far End Fault error pattern as being equivalent to loss of link. The net effect of this is that when either fiber is disconnected, link is dropped on the other side of the converter. Normally, only the disconnection of the Receive fiber would cause this reaction.

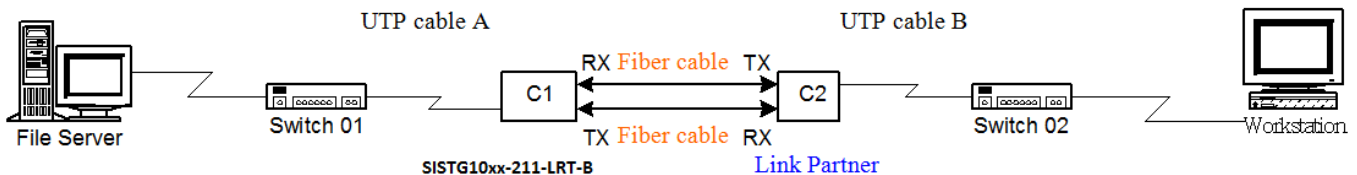

Note that DIP Switch must be set to Enabled for LFP to work. See “DIP Switch for Feature Selection” on page 22.

Copper (RJ-45) Cable Specifications

Shielded twisted-pair (STP) or unshielded twisted-pair (UTP) cabling may be used and can be configured as either Straight-through or crossover.

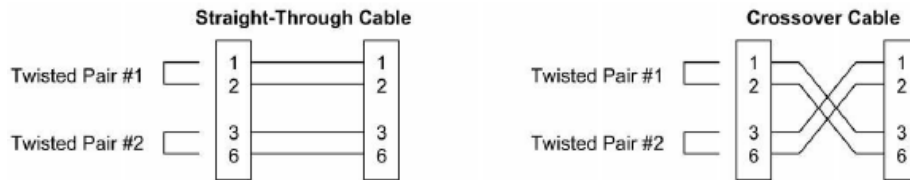

Note: The AutoCross feature determines the characteristics of the cable connection and automatically configures the unit to link up, regardless of the cable configuration, allowing either straight-through (MDI) or crossover (MDI-X) cables to be used. Requires no operator intervention. See [Advanced Feature Descriptions](#) on page 14 for more information.

Wire category: Category 5 (minimum)
 Attenuation: 22.0 dB /100m @ 100 MHz
 Gauge: 24 to 22 AWG
 Max. cable distance: 100 meters (328 ft.)

RJ-45 pinouts

The RJ-45 connector pin assignment chart for 10Base-T or 100Base-TX is shown below.

#	MDI Signal Name	MDI-X Signal Name
1	Receive Data + (RD+)	Transmit Data + (TD+)
2	Receive Data - (RD-)	Transmit Data - (TD-)
3	Transmit Data + (TD+)	Receive Data + (RD+)
6	Transmit Data - (TD-)	Receive Data - (RD-)

Note: The Media Converter is configured as a MDI-X device.

Fiber Cable and Optic Specifications

Note: The fiber optic transmitters on this device meet Class I Laser safety requirements per IEC-825/CDRH standards and comply with 21CFR1040.10 and 21CFR1040.11.

Fiber Cable Characteristics

Cable physical characteristics must meet or exceed IEEE 802.3™ specifications:

Bit Error Rate:	<10 ⁻⁹
Single mode fiber:	9 μm
Multimode fiber:	62.5/125 μm
Multimode fiber:	100/140, 85/140, 50/125 μm

SISTG1013-211-LRT-B 850 nm multimode
 Fiber-optic transmitter power: min: -9.0 dBm max: -1.0 dBm
 Fiber-optic receiver sensitivity: min: -19.0 dBm max: -1.0 dBm
 Link budget: 10.0dB

SISTG1014-211-LRT-B 1310 nm single mode
 Fiber-optic transmitter power: min: -9.5 dBm max: -3.0 dBm
 Fiber-optic receiver sensitivity: min: -20.0 dBm max: -3.0 dBm
 Link budget: 10.5 dB

SISTG1040-211-LRT-B Values will be determined by the SFP used.

Power Supply Features and Specifications

Two Industrial Power Supply options are available (sold separately).

25135 Industrial Power Supply Optional Accessory

Input: 85 -264VDC, 120-370VDC. Output: 24VDC, 10Watts, -20°C to +70°C.
 See the Transition Networks [webpage](#) for more information.

SPS-UA12DHT Industrial Power Supply Optional Accessory

Input: 90 ~ 264 VAC. Output: 12 VDC, 1.3A, 18 Watts
 See the Transition Networks [webpage](#) for more information.



About This Manual

This manual describes how to install and troubleshoot the SISTG10xx-211-LRT-B, including how to:

- Install the Media Converter.
- Check the Media Converter status LED behavior.
- Reset the Media Converter or restore it to factory defaults.
- Troubleshoot Media Converter installation.

Related Manuals

A printed Quick Start Guide is shipped with each Media Converter.

For Transition Networks Drivers, Firmware, etc. go to the [Product Support](#) webpage (logon required).

For Manuals, Application Notes, Brochures, Data Sheets, Specifications, etc. go to the [Support Library](#) (no logon required).

Note that this manual may provide links to third party web sites for which Transition Networks is not responsible.

Installation

This section provides SISTG1040-2x2-LRT Media Converter installation and setup information.

Installation Overview

The procedural overview below assumes that you have already selected an appropriate install location and have acquired the appropriate equipment needed (e.g., a power cord, Cat5 or better cable for the TP (RJ-45) port, SC SM, or SC MM fiber cable for FX (SFP) port).

1. Unpack and verify package contents.
2. Review the front, back and top panel information.
3. Read the DIP switch and RESET button descriptions.
4. Perform DIN Rail Mounting.
5. Install SFP Modules.
6. Connect to Network / Devices.
7. Connect Fiber cables.
8. Connect Copper cables and verify Copper cable configuration.
9. Perform Media Converter grounding.
10. Connect power wires to the Media Converter's Terminal Block.
11. Provide and attach a Power Cord to the Media Converter.
12. Connect the Power Cord to the power supply.
13. Connect the power supply to a live AC outlet.

Package Contents

Verify that you have received the items below. Contact your sales representative if any item is missing. Please save the packaging for possible future use.

Qty	Description
1	SISTG10xx-211-LRT-B series Media Converter
1	DIN-Rail mounting kit
1	Quick Start Guide, 33758
--	External AC/DC power supply (sold separately)



Unpacking

Unpack and verify the contents in their install location.

Front Panel

The SISTG10xx-211-LRT-B front panels are shown below.

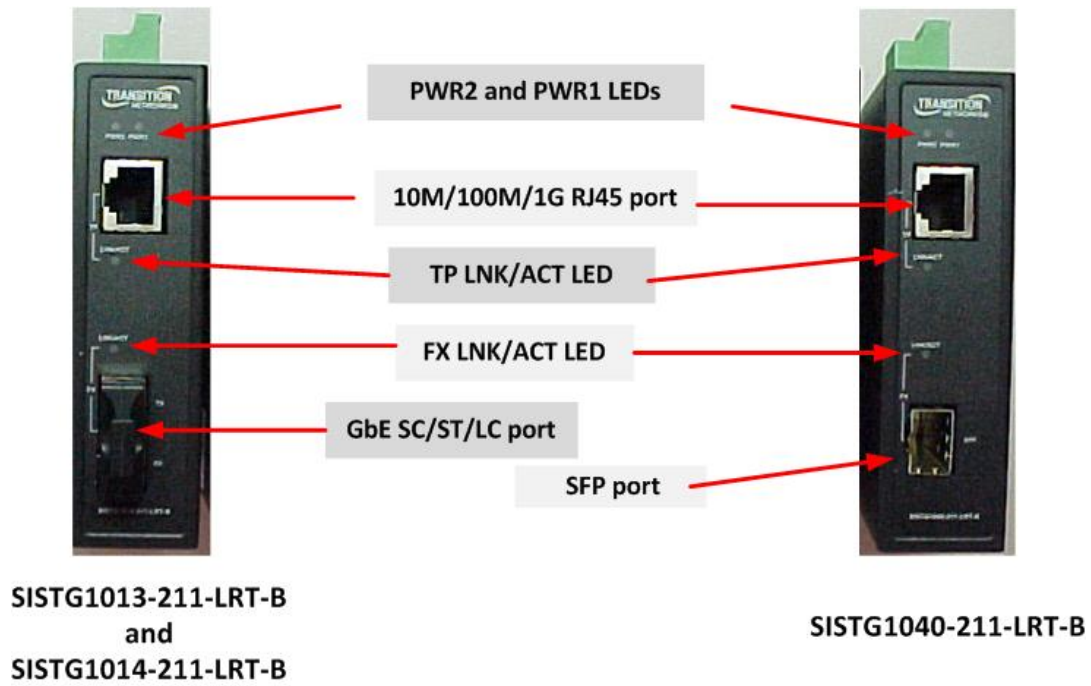

Back Panel

The back panel is shown below.

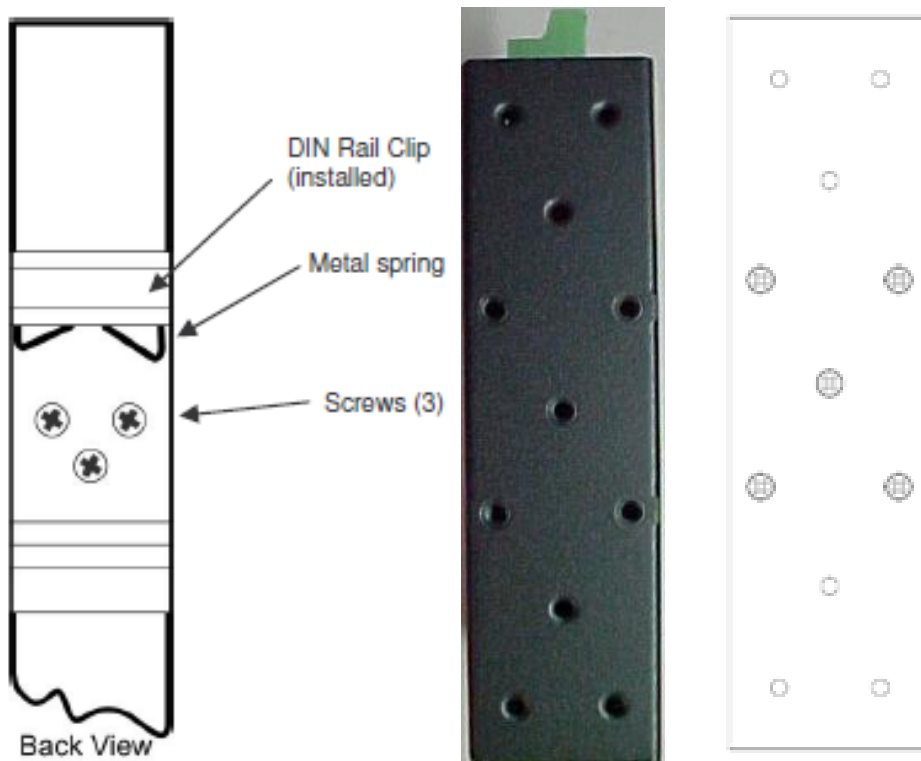

Top Panel

The SISTG10xx-211-LRT-B top panel provides the RESET button, DIP Switch, Terminal Block, and Ground Screw as shown and described below.

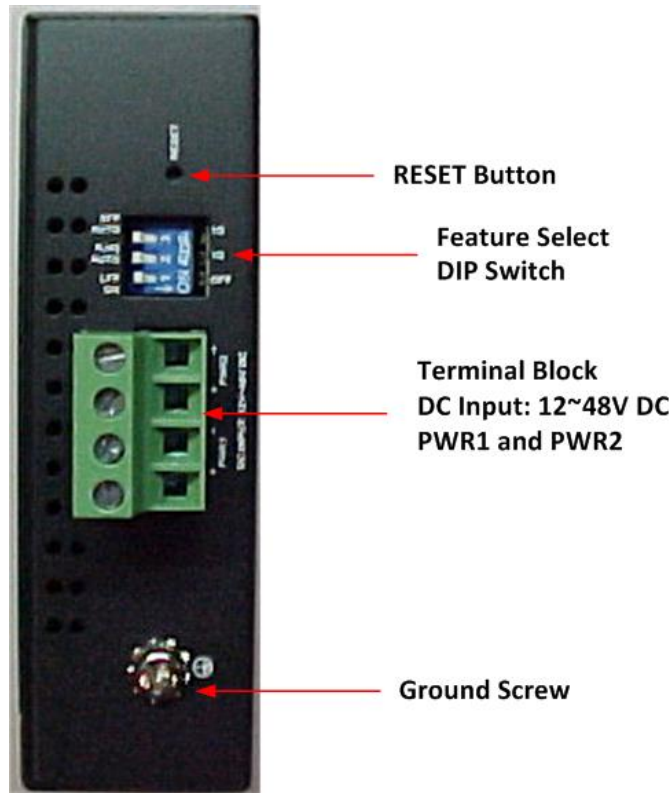

SISTG10xx-211-LRT-B Top Panel

RESET Button

The top panel RESET button can be used to reset the Media Converter, clear the MAC address table, and flash the TP and SFP LNK/ACT LEDs momentarily.

You can use a paper clip or something similar to press the recessed RESET button.

Task	Press Button for	PWR LED	Port Status LED
Reset the Converter	2 ~ 7 seconds	On Green	ALL LEDs Light OFF

DIP Switch for Feature Selection

The SISTG10xx-211-LRT-B has a 3-position DIP switch on the top panel used to configure the Media Converter for use in a particular network setting. The 3-position DIP switch is shown and described below.



SISTG1040-211-LRT-B



SISTG1013-211-LRT-B and SISTG1014-211-LRT-B

SISTG1040-211-LRT-B DIP Switch Settings

DIP	State	Description
3 SFP	AUTO	Enables Auto Negotiation for the SFP Port.
	1G	The SFP Fiber port is forced to 1Gbps.
2 RJ45	AUTO	Enables Auto Negotiation for the RJ45 Port.
	1G	The RJ45 port is forced to 1Gbps.
1 LFP	ON	Enables Link Fault Pass-through. If a link fails on one interface of the media converter, the media converter will force the link down on its link partner and then forward it to the next interface.
	OFF	Disables Link Fault Pass-through.

SISTG1013-211-LRT-B and SISTG1014-211-LRT-B DIP Switch Settings

DIP	State	Description
3 SC/ST/LC	N/A	The SC/ST/LC Fiber port is forced to 1Gbps.
	N/A	The SC/ST/LC Fiber port is forced to 1Gbps.
2 RJ45	AUTO	Enables Auto Negotiation for the RJ45 Port.
	1G	The RJ45 port is forced 1G.
1 LFP	ON	Enables Link Fault Pass-through. If a link fails on one interface of the media converter, the media converter will force the link down on its link partner and then forward it to the next interface.
	OFF	Disables Link Fault Pass-through.

DIN Rail Mounting

The Media Converter includes an aluminum DIN Rail Clip attached to the rear panel. Verify the clip is attached and oriented as shown below.

DIN Rail Mounting Considerations: consider the following before mounting the DIN rail to a surface and attaching the Media Converter:

- The surface must support at least 450g (1.0 lbs.) for the Media Converter.
- Do not place heavy objects on the Media Converter.

CAUTION: Mount the Media Converter with proper spacing around it for ventilation (heat dissipation). Failure to observe this caution could result in damage to the Media Converter.

CAUTION: Please exercise caution when using power tools. Do not install this unit in damp or wet locations, or in close proximity to very hot surfaces. Failure to observe this caution could result in damage to the Media Converter and cables.

To mount the Media Converter to the DIN rail, see the figure and do the following:

1. Attach the DIN Rail mounting kit to rear panel of the chassis. Insert screws and tighten then with a screwdriver to secure the kit.

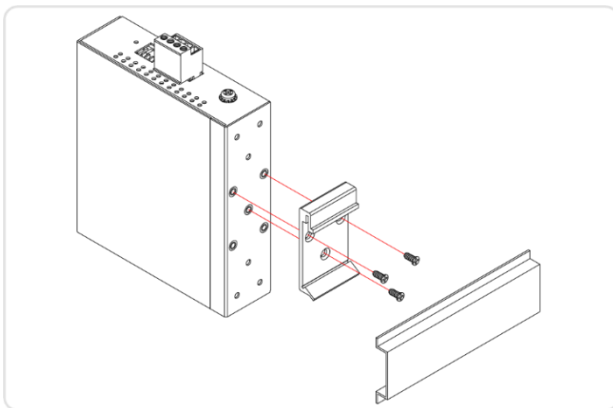

2. Insert the upper lip of the DIN rail into the DIN-rail mounting kit. And press the converter towards the DIN rail until it snaps into place.

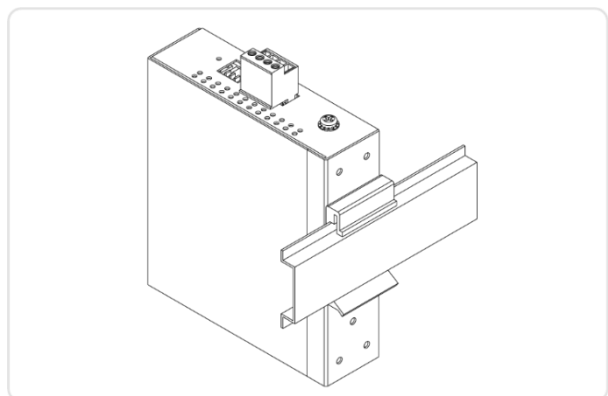
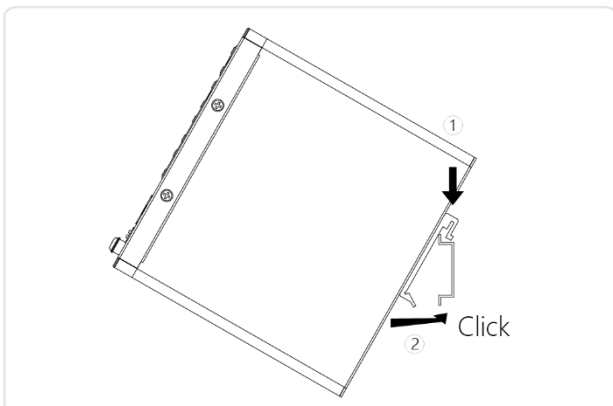

3. Make sure that the converter is attached securely to DIN Rail.

Installing SFP Modules

The Media Converter provides two 100M/1G SFPs. You can install or remove a mini-GBIC SFP module from a SFP port without having to power off the Media Converter. Transition Networks offers a full line of small form factor pluggable (SFP) transceivers. See our [SFP webpage](#) for details. Refer to the specific SFP manual for **cautions** and **warnings**. **Note:** The SFP ports should use a UL Listed Optional Transceiver product, Rated 3.3Vdc, Laser Class 1.

1. Insert the module into the SFP port (cage).
2. With the SFP module aligned correctly (label facing right), slide the module into the SFP slot until you hear a click.
3. Press firmly to ensure that the module seats into the connector.

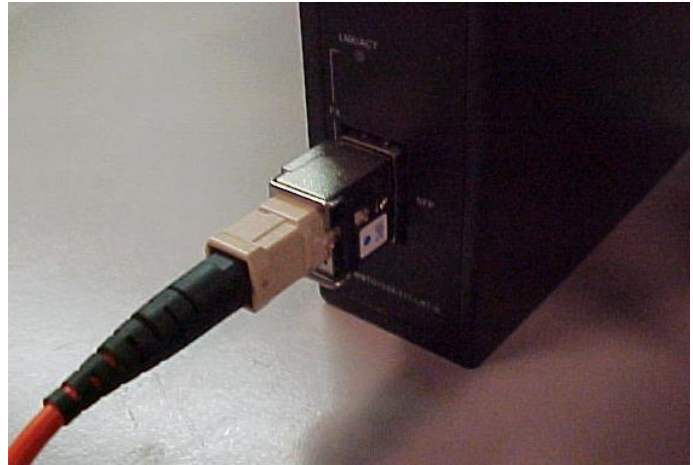

4. Insert the fiber cable into the transceiver.

Connecting to Network / Devices

The Media Converter provides an RJ45 ports. Use Cat 5e or better unshielded twisted pair (UTP) cable terminated with an RJ-45 connector.

- Use four twisted-pair, Category 5e or above cabling for RJ-45 port connection. The cable between the Media Converter and the link partner (switch, hub, PC, etc.) must be less than 100 meters (328 ft.) long.
- A Fiber segment using single-mode (SM) connector type must use 9/125 μ m single-mode fiber cable.
- A Fiber segment using multi-mode (MM) connector type must use 50 or 62.5/125 μ m multi-mode fiber cable.



Connecting Fiber Cables

When connecting fiber cables to the fiber port on the Media Converter, be sure the correct type is used: SC SM or SC MM.

To install the fiber cables, do the following:

1. Remove and keep the fiber-port protective dust cover(s).

Note: When not connected to a fiber cable, keep the protective cover(s) on the optical ports to protect the optics and keep dust and debris from entering the optical interface.

2. Check that the fiber connectors on the fiber-optic cabling are clean. If necessary, clean the fiber connectors using locally accepted cleaning procedures.

Note: Dirty fiber connectors on fiber optic cables will impair light transmission quality through the cable and lead to degraded performance on the port.

3. Connect the fiber cable as shown below.

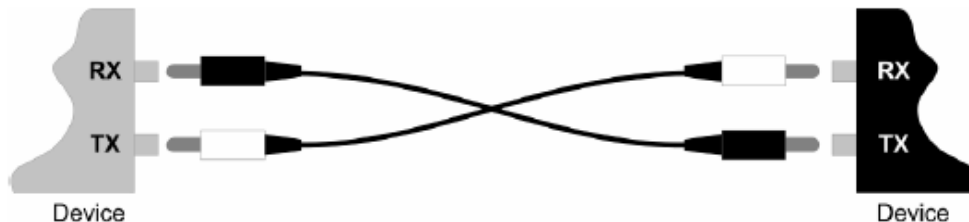

4. Check the corresponding fiber port LED on the Media Converter to verify the connection—LNK/ACT LED should light.

Warning:

- Visible and invisible laser radiation when open: DO NOT stare into the beam, or directly view the beam with optical instruments. Failure to observe this warning could result in an eye injury.
- Use of controls, adjustments or the performance of procedures other than those specified herein may result in hazardous radiation exposure.

SM (Singlemode) fiber patch cables are typically used for transmitting data over long distances (e.g., connections over large areas, such as college campuses and cable television networks). SM cables have a higher bandwidth than multimode cables to deliver up to twice the throughput. Most single mode cabling is color-coded yellow.



MM (Multimode) fiber patch cables are typically used for transmitting data and voice signals over shorter distances (e.g., for data and audio/visual applications in local-area networks and connections within buildings). Multimode cables are often color-coded orange or aqua; the aqua fiber patch cables are for higher performance such as 10Gbps, 40Gbps, and 100Gbps Ethernet and fiber channel applications.



Connecting Copper Cables

To connect the copper cable to the Media Converter and other equipment, do the following:

1. Locate or build 10Base-T or 100Base-TX or 1000Base-T compliant copper cables with male, RJ-45 connectors installed at both ends.
2. Connect the RJ-45 connector at one end of the cable to the RJ-45 port on the media converter.
3. Connect the RJ-45 connector at the other end of the cable to the RJ-45 port on the other device (switch, workstation, PLC, etc.).
4. Check the copper port LED on the Media Converter to verify the connection; the LNK/ACT LED should light.

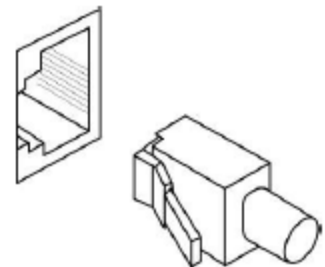

Copper Cable Configuration

Either a straight-through or cross-over cable may be used.

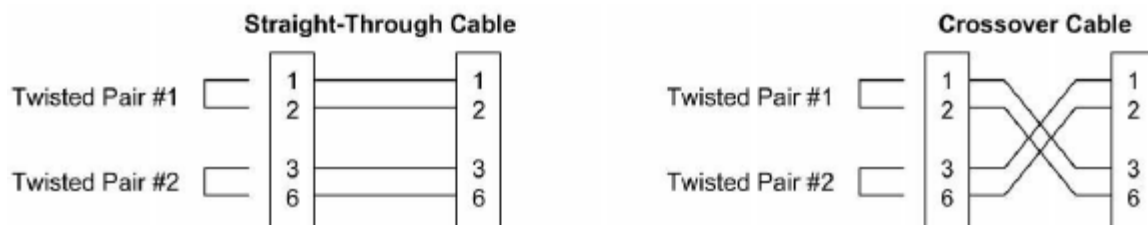

Note: The AutoCross feature determines the characteristics of the cable connection and automatically configures the unit to link up, regardless of the cable configuration, allowing either straight-through (MDI) or crossover (MDI-X) cables to be used. (Requires no operator intervention.) See Advanced Features section for more information.

Ground Screw - Grounding the Media Converter

Grounding the Media Converter helps limit the effects of noise due to electromagnetic interference (EMI) via proper grounding. Always run the ground connection from the ground screw to a grounding surface before connecting the Media Converter to a DC power source.



Wiring considerations: consider the following wiring recommendations:

- Signal lines must not be directly connected to outdoor wiring.
- Use separate paths or conduits to route wiring for power and device data cables. To avoid interference, wires with different signal characteristics route separately. If power wiring and device data cables must cross make sure that the wires are perpendicular at the intersection point.
- Use the type of signal transmitted through a wire to determine which wires should be kept separate. The rule of thumb is wiring that shares similar electrical characteristics can be bundled together.
- Keep input and output wiring separated.

CAUTION: The Media Converter is intended to be grounded to a well-grounded mounting surface such as a metal plate. Install the grounding wire prior to connecting any other device to the Media Converter.

CAUTION: Be sure to disconnect the Media Converter from the DC power source before installing and wiring the device.

Connecting Power to the Media Converter

The Media Converter has dual (redundant) power inputs providing over current protection and reverse polarity protection. The dual power inputs can be connected simultaneously to live DC power sources. If one power source fails, the other live source acts as a backup, and automatically supplies the Media Converter with power.

IMPORTANT

- Power is supplied through an external 12-48 VDC power source. Check the Technical Specification section for details about the DC power input voltage.
- The Media Converter does not include a power switch; therefore, plugging a wired and active terminal-block plug into its terminal block will immediately power ON the unit.

CAUTION: Before connecting the Media Converter to a DC power source, ensure the power source is stable.

CAUTION: This device is intended to be supplied by a listed power source marked LPS or Limited Power Source, provided with a connector for field wiring terminal.

CAUTION: This device is designed for operation with a safety extra-low voltage (SELV) in compliance IEC62368-1/EN62368-1/ VDE0805 and in compliance with the low voltage directive 73/23/EEC and 93/68/EEC.

Power Connection: Warning: Connect the power supply to the switch first, and then connect the power supply to power. Otherwise catastrophic product failure may occur.

1. Verify that power is off to the DC circuit that you are going to attach to the switch PoE DC-input connector. This can be either of the two power supplies (AC-input or DC-input) or site source DC.
2. As an added precaution, place an appropriate safety flag and lockout device at the source power circuit breaker, or place a piece of adhesive tape over the circuit breaker handle to prevent accidental power restoration while you are working on the circuit.

Power Disconnection: To disconnect power from the switch after a successfully boot: **1.** Turn off power to the switch. **2.** Disconnect the cables.

Terminal Block Wiring

You can wire the 4-position terminal block for redundant power. **Note:** The 4-position terminal-block plug is constructed (keyed) to mate with the Media Converter terminal block. When wiring the plug for power, use the polarity markings next to the terminal block to ensure proper connection. **Note:** The power source must be powered off when connecting and disconnecting this product.

1. Turn the external power source OFF.
2. Strip the power wires as required.
3. Insert one stripped power wire into the terminal block plug. Observe polarity (positive / negative DC wires into the **PWR1 +** and **-** terminals, and optionally into the **PWR2 +** and **-** terminals).
4. Secure the wire using a flathead screwdriver by tightening the contact screw.
5. Repeat Steps 3 and 4 until all wires are installed and secured.
6. Insert the terminal block plug into the Media Converter's terminal block.
7. Make sure that the DC power source is stable and clean.
8. Turn ON the power source and the PWR LED should turn ON along with PWR 1 LED and/or PWR 2 LED, depending on whether one or both power supplies are connected and turned ON.

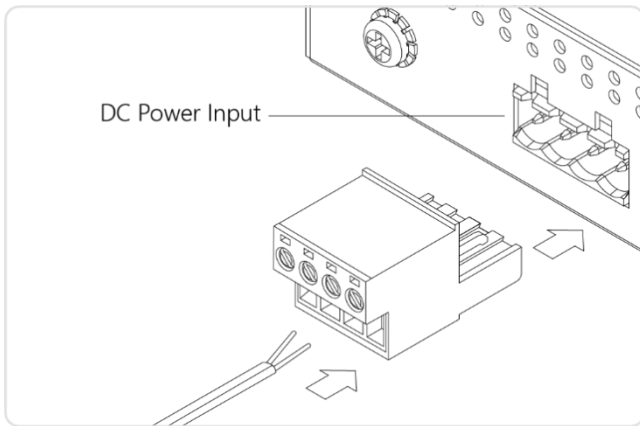

Power Cord

The SISTG10xx-211-LRT-B ships with no Power Cord. The SISTG1040-2x2-LRT can be ordered with optional accessories (sold separately) including Industrial Power Supply SPS-UA12DHT or 25135.

Power Supply - Optional Accessories (sold separately)

SPS-UA12DHT: Input: 90-264VAC. Output: 12 VDC, 1.3A, 18 Watts. See the Transition Networks [webpage](#) for more information.

25135: Input: 85 -264VDC, 120-370VDC. Output: 24VDC, 10Watts, -20°C to +70°C. See the Transition Networks [webpage](#) for more information.

The figure below shows a SISTG1040-211-LRT-B with PWR1 wired to a 25135 (DR-120-24) power supply.

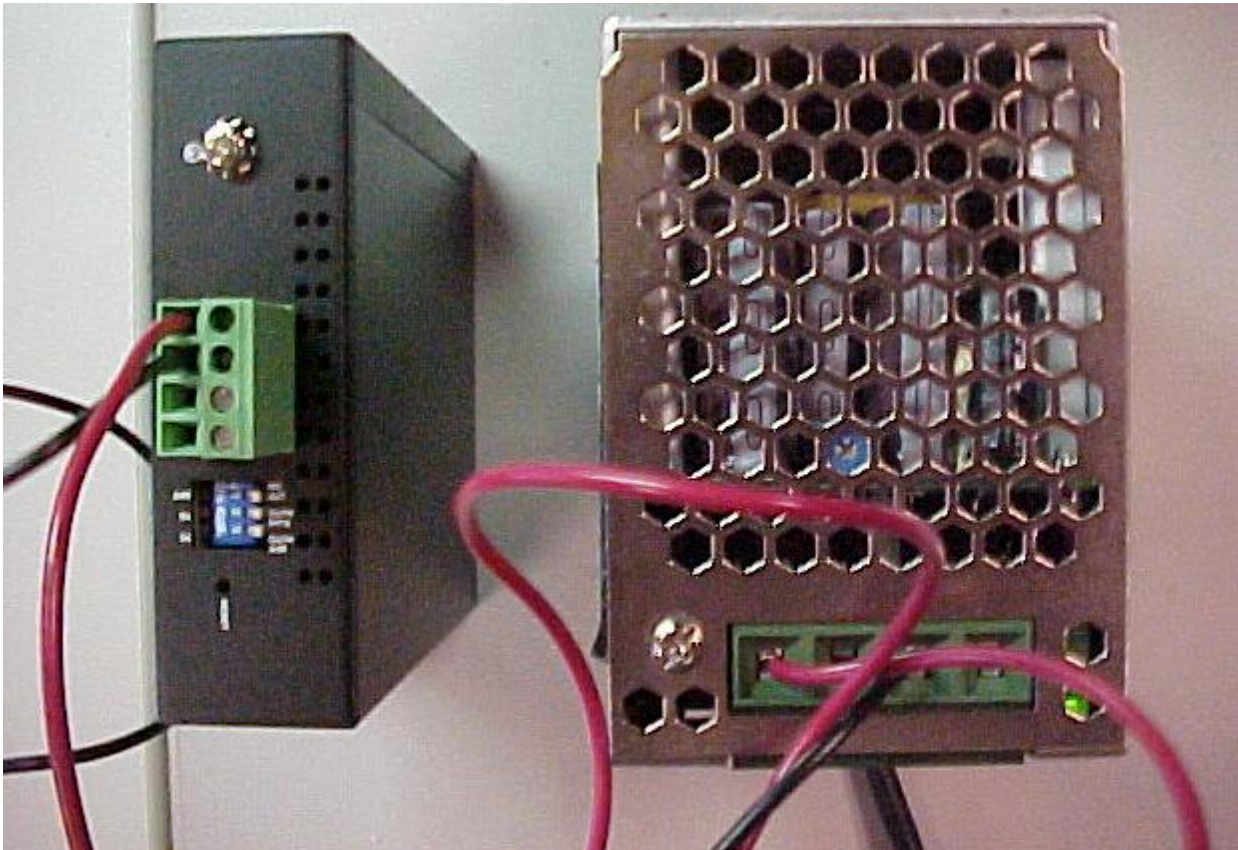

LEDs

The Media Converter has LED indicators located on its front panel. The LEDs present at-a-glance network status, and provide real-time connectivity information.

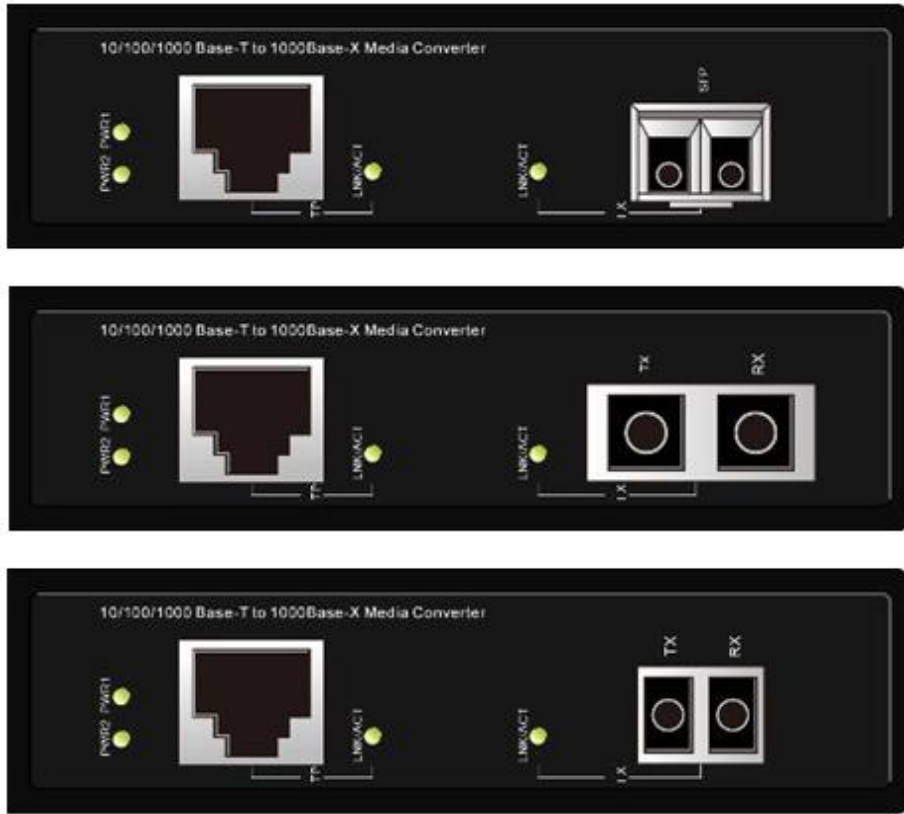

The front panel LEDs provide converter status checking and monitoring. The two types of LEDs are:

- Power LED: indicates if the converter is powered up correctly.
- Port Status LEDs: indicates the current status of each port.

The following table details the functions and descriptions of various LED indicators.

Type	LED		Color	Function
Global	System	PWR 1	Green	Lit when power 1 is coming up. Off when power 1 off.
		PWR 2	Green	Lit when power 2 is coming up. Off when power 2 off.
Global	Port	RJ45 Port LNK/ACT	Green	Lit when RJ45 port connection is good. Blinks when RJ45 port data is present. Off when RJ45 port is link down.
		Fiber Port LNK/ACT	Green	Lit when fiber port connection is good. Blinks when fiber port data is present. Off when fiber port is link down.

Troubleshooting

Basic Troubleshooting

1. Make sure your Media Converter model supports the feature or function attempted; see chapter 1.
2. Verify the install process; see chapter 2.
3. Troubleshoot connected network devices to pinpoint the problem to the Media Converter.
4. Verify that you are using the right power cord and power supply (+12~48 VDC). Don't use a power supply with DC output voltage higher than 48V, or it will burn out the Media Converter.
5. Select the proper UTP and Fiber cable to construct your network. The single-mode converter must use single-mode fiber cable. Verify that you are using the right cable.
6. Check the configuration DIP switch. It must be set to the same operating mode as the link partner.

LED Troubleshooting

If the power LED does not light when the power cord is plugged in, you may have a problem with power cord. Check for loose power connections, power losses or surges at power outlet.

If the LED indicators are normal and the connected cables are correct but packets still cannot transmit, check your system's Ethernet devices configuration or status.

Problem	Possible Cause	Potential Solution
Power LED is Off	<ol style="list-style-type: none"> 1. The terminal block plug is not fully inserted into the Media Converter. 2. The Power LED is not lit. 	<ol style="list-style-type: none"> 1. Wire and insert the terminal block plug into the Media Converter's terminal block. 2. Make sure DC power is at suggested levels. 3. Contact TN Tech Support.
No link or activity on UTP (copper) port	<ol style="list-style-type: none"> 1. The Power LED is not lit. 2. The UTP cable is not properly installed at both ends. 3. LPT is not enabled. LPT requires both a copper and fiber connection at the same time to establish link. 	<ol style="list-style-type: none"> 1. Verify that power is turned on. 2. Verify that the cable at both ends is properly installed. 3. Disable DIP switch #2 (OFF). If the LNK/ACT lights, check the UTP cabling and re-enable DIP switch #2.
No link or activity on Fiber port	<ol style="list-style-type: none"> 1. The Power LED is not lit. 2. The UTP cable is not properly installed at both ends. 3. LPT is not enabled. LPT requires both a copper and fiber connection at the same time to establish link. 	<ol style="list-style-type: none"> 1. Verify that power is turned on. 2. Verify that the cable at both ends is properly installed on both ends. 3. Disable DIP switch #2 (OFF) – if LNK/ACT lights, check the UTP cabling and re-enable DIP switch #2.

The following table provides information for users to easily troubleshoot problems by taking actions based on the suggested solutions within.

Symptoms	Possible Causes	Suggested Solutions
Power LED is Off	The converter is not receiving power.	<ol style="list-style-type: none"> 1. Check if correct power cord is connected firmly to the converter and to the DC outlet socket. 2. Perform power cycling the converter by unplugging and plugging the power cord back into the converter. 3. If the LED is still off, try to plug power cord into different DC outlet socket to make sure correct DC source is supplied.
Port Status LED is Off	The port is not connected or the connection is not working.	<ol style="list-style-type: none"> 1. Check if the cable connector plug is firmly inserted and locked into the port at both the converter and the connected device. 2. Make sure the connected device is up and running correctly. 3. If the symptom still exists, try different cable or different port, in order to identify if it is related to the cable or specific port.

Device Label and Box Label

In addition to the device CLI and Web GUI, you can find device information on the Device Label (left) and Box Label (right).



Device Label



Box Label

The Device label was update in July 2019 to reflect UL C1D2 Temperature code change:



Before July 2019



After July 2019

Record Device and System Information

After performing the troubleshooting steps, and before calling or emailing Technical Support, please record as much information as possible in order to help the Transition Networks Tech Support Specialist.

1. Record MODEL: _____

S/N: _____ P/N: _____

2. Record LED Status: _____

3. Provide additional information to your Tech Support Specialist. See the "Troubleshooting" section above.

Your Transition Networks service contract number: _____

Describe the failure: _____

Describe any action(s) already taken to resolve the problem (e.g., changing mode, rebooting, etc.): _____

The serial and revision numbers of all involved Transition Networks products in the network: _____

Describe your network environment (layout, cable type, etc.): _____

Network load and frame size at the time of trouble (if known): _____

The device history (i.e., have you returned the device before, is this a recurring problem, etc.): _____

Any previous Return Material Authorization (RMA) numbers: _____

Regulatory and Safety Information

Compliance and Safety Statements

FCC, Class A: This product has been tested and found to comply with the limits for a Class A digital device pursuant to Part 15 of the FCC Rules. These limits are designed to provide reasonable protection against harmful interference when the equipment is operated in a commercial environment. This product generates, uses, and can radiate radio frequency energy and, if not installed and used in accordance with the manufacturer's instruction manual, may cause harmful interference with radio communications. Operation of this product in a residential area is likely to cause harmful interference, in which case you will be required to correct the interference at your own expense.

This device complies with Part 15 of the FCC Rules. Operation is subject to the following two conditions:

- 1) This device may not cause harmful interference.
- 2) This device must accept any interference received, including interference that may cause undesired operation.

CE MARK DECLARATION OF CONFORMANCE FOR EMI AND SAFETY (EEC): This equipment has been tested and found to comply with the protection requirements of European Emission Standard EN55022/EN61000-3 and the Generic European Immunity Standard EN55024.

Cautions and Warnings

Definitions

Cautions indicate that there is the possibility of poor equipment performance or potential damage to the equipment. **Warnings** indicate that there is the possibility of injury to person.

Cautions and Warnings appear here and may appear throughout this manual where appropriate. Failure to read and understand the information identified by this symbol could result in poor equipment performance, damage to the equipment, or injury to persons.

Cautions

While installing or servicing the power module, wear a grounding device and observe all electrostatic discharge precautions. Failure to observe this caution could result in damage to, or failure of the power module.

Warnings

Warning: Do not connect the power module to an external power source before installing it into the chassis. Failure to observe this warning could result in an electrical shock, even death.

WARNING: The power module has a provision for grounding. Equipment grounding is vital to ensure safe operation. The installer must ensure that the power module is properly grounded during and after installation. Failure to observe this warning could result in an electric shock, even death.

WARNING: A readily accessible, suitable National Electrical Code (NEC) or local electrical code approved disconnect device and branch-circuit protector must be part of the building's installed wiring to accommodate permanently connected equipment. Failure to observe this warning could result in an electric shock, even death.

WARNING: Turn the external power source OFF and ensure that the power module is disconnected from the external power source before performing any maintenance. Failure to observe this warning could result in an electrical shock, even death.

WARNING: Ensure that the disconnect device for the external power source is OPEN (*turned OFF*) before disconnecting or connecting the power leads to the power module. Failure to observe this warning could result in an electric shock, even death.

See Electrical Safety Warnings below for Electrical Safety Warnings translated into multiple languages.

Declaration of Conformity

Declaration of Conformity

Manufacture's Name: Transition Networks, Inc.

Manufacture's Address: 10900 Red Circle Drive, Minnetonka, Minnesota 55343 U.S.A.

Declares that the product(s): SISTG1013-211-LRT-B, SISTG1040-211-LRT-B, and SISTG1014-211-LRT-B

Conform to the following Product Regulations:

FCC Part 15 Class A, EN 55032:2012, EN 55024:2010 Directive 2014/30/EU

EN 55032:2015 +AC:2016, Class A. CISPR 32:2015 +Cor 1:2016, Class A. AS/NZS CISPR 32:2015, Class A.

EN 61000-3-2:2014, Class A. EN 61000-3-3:2013. EN 55024:2010. EN 61000-4-2:2009 / IEC 61000-4-2:2008 ED.

2.0. EN 61000-4-3:2006 +A1:2008 +A2:2010 / IEC 61000-4-3:2010 ED. 3.2.

EN 61000-4-4:2012 / IEC 61000-4-4:2012 ED. 3.0. EN 61000-4-5:2006 / IEC 61000-4-5:2005 ED. 2.0.

EN 61000-4-6:2014 / IEC 61000-4-6:2013 ED. 4.0. EN 61000-4-8:2010 / IEC 61000-4-8:2009 ED 2.0.

EN 61000-4-11:2004 / IEC 61000-4-11:2004 ED 2.0.

47 CFR FCC Rules and Regulations Part 15 Subpart B, Class A Digital Device. ICES-003 Issue 6, Class A.

Low-Voltage Directive 2014/35/EU IEC 62368-1:2014 (Second Edition); and/or EN 62368-1:2014/A11:2017;

and/or BS EN 62368-1:2014+A11:2017.

2011/65/EU EN 50581:2012; UL; Class 1 Div 2

With the technical construction on file at the above address, this product carries the **CE Mark**.

I, the undersigned, hereby declare that the equipment specified above conforms to the above Directive(s) and Standard(s).

Place: Minnetonka, Minnesota

Date: July 28, 2021

Signature: Stephen Anderson

Full Name: Stephen Anderson Position: Vice President of Engineering

Warning and Caution - Proper Installation and Operation (English)

These devices are open-type devices that are to be installed in an enclosure only accessible with the use of a tool, suitable for the environment. This equipment is suitable for use in Class I, Division 2, Groups A, B, C, and D or non-hazardous locations only. WARNING – EXPLOSION HAZARD. DO NOT DISCONNECT WHILE THE CIRCUIT IS LIVE OR UNLESS THE AREA IS FREE OF IGNITIBLE CONCENTRATIONS.

Avertissement et mise en garde - Installation et fonctionnement corrects (français)

Ces périphériques sont des périphériques de type ouvert qui doivent être installés dans une enceinte uniquement accessible à l'aide d'un outil, adapté à l'environnement. Cet équipement peut être utilisé dans la classe I, division 2, groupes A, B, C, et D ou des emplacements non dangereux seulement. AVERTISSEMENT - RISQUE D'EXPLOSION. NE PAS SE DÉCONNECTER LORSQUE LE CIRCUIT EST VIVANT OU À MOINS QUE LA ZONE NE SOIT LIBRE DE CONCENTRATIONS IGNIFIABLES.

High Risk Activities Disclaimer

Components, units, or third-party products used in the product described herein are NOT fault-tolerant and are NOT designed, manufactured, or intended for use as on-line control equipment in the following hazardous environments requiring fail-safe controls: the operation of Nuclear Facilities, Aircraft Navigation or Aircraft Communication Systems, Air Traffic Control, Life Support, or Weapons Systems ("High Risk Activities"). Transition Networks and its supplier(s) specifically disclaim any expressed or implied warranty of fitness for such High Risk Activities.

Notices : The information in this user's guide is subject to change. For the most current SISTG10xx-211-LRT-B information refer to the online user guide at <https://www.transition.com>.

Product is certified by the manufacturer to comply with DHHS Rule 21/CFR, Subchapter J applicable at the date of manufacture.

Notices: Not Designed for Use in Life Support Equipment or Applications: These products are not designed for use in life support equipment or applications that would cause a life-threatening situation if any such product failed. Do not use this product in these types of equipment or applications.

ERN # : ERN # (Encryption Registration Number) R111839 (self-declaring).

IMPORTANT Copper based media ports: e.g., Twisted Pair (TP) Ethernet, USB, RS-232, RS422, RS485, DS1, DS3, Video Coax, etc., are intended to be connected to intra-building (inside plant) link segments that are not subject to lightning transients or power faults. Copper based media ports: e.g., Twisted Pair (TP) Ethernet, USB, RS-232, RS-422, RS-485, DS1, DS3, Video Coax, etc., are NOT to be connected to inter-building (outside plant) link segments that are subject to lightning transients or power faults. Failure to observe this caution could result in damage to equipment.

Warning: Visible and invisible laser radiation when open: Do not stare into the beam or view the beam directly with optical instruments. Failure to observe this warning could result in an eye injury or blindness.

WARNING: Use of controls, adjustments or the performance of procedures other than those specified herein may result in hazardous radiation exposure.

Electrical Safety Warnings

Electrical Safety

IMPORTANT: This equipment must be installed in accordance with safety precautions.

Elektrische Sicherheit

WICHTIG: Für die Installation dieses Gerätes ist die Einhaltung von Sicherheitsvorkehrungen erforderlich.

Elektrisk sikkerhed

VIGTIGT: Dette udstyr skal installeres i overensstemmelse med sikkerhedsadvarslerne.

Elektrische veiligheid

BELANGRIJK: Dit apparaat moet in overeenstemming met de veiligheidsvoorschriften worden geïnstalleerd.

Sécurité électrique

IMPORTANT: Cet équipement doit être utilisé conformément aux instructions de sécurité.

Sähköturvallisuus

TÄRKEÄÄ: Tämä laite on asennettava turvaohjeiden mukaisesti.

Sicurezza elettrica

IMPORTANTE: questa apparecchiatura deve essere installata rispettando le norme di sicurezza.

Elektrisk sikkerhet

VIKTIG: Dette utstyret skal installeres i samsvar med sikkerhetsregler.

Segurança eléctrica

IMPORTANTE: Este equipamento tem que ser instalado segundo as medidas de precaução de segurança.

Seguridad eléctrica

IMPORTANTE: La instalación de este equipo deberá llevarse a cabo cumpliendo con las precauciones de seguridad.

Elsäkerhet

OBS! Alla nödvändiga försiktighetsåtgärder måste vidtas när denna utrustning används.

Service, Warranty and Tech Support

Warranty

Five-Year Limited Hardware Warranty

Transition Networks warrants to the original consumer or purchaser that each of its Liberator, PacketBand, DataBand, MILAN brand switch and media converters, S4140, S4224 products and all components thereof, will be free from defects in material and/or workmanship for a period of five years from the original factory shipment date. Any warranty hereunder is extended to the original consumer or purchaser and is not assignable. Transition Networks makes no express or implied warranties including, but not limited to, any implied warranty of merchantability or fitness for a particular purpose, except as expressly set forth in this warranty. In no event shall Transition Networks be liable for incidental or consequential damages, costs, or expenses arising out of or in connection with the performance of the product delivered hereunder. Transition Networks will in no case cover damages arising out of the product being used in a negligent fashion or manner.

Transition Networks will, at its option:

- Repair the defective product to functional specification at no charge
- Replace the product with an equivalent functional product
- Refund a portion of purchase price based on a depreciated value

To return a defective product for warranty coverage, contact Transition Networks' [Customer Support](#) for a return authorization number.

Send the defective product postage and insurance prepaid to the following address:

Transition Networks, Inc.
10900 Red Circle Drive
Minnetonka, MN 55343
USA

Attn: RETURNS DEPT: CRA/RMA # _____

Failure to properly protect the product during shipping may void this warranty. The return authorization number must be written on the outside of the carton to ensure its acceptance. We cannot accept delivery of any equipment that is sent to us without a CRA or RMA number.

CRA's are valid for 60 days from the date of issuance. An invoice will be generated for payment on any unit(s) not returned within 60 days.

Upon completion of a demo/ evaluation test period, units must be returned or purchased within 30 days. An invoice will be generated for payment on any unit(s) not returned within 30 days after the demo/ evaluation period has expired.

The customer must pay for the non-compliant product(s) return transportation costs to Transition Networks for evaluation of said product(s) for repair or replacement. Transition Networks will pay for the shipping of the repaired or replaced in-warranty product(s) back to the customer (any and all customs charges, tariffs, or/and taxes are the customer's responsibility).

Before making any non-warranty repair, Transition Networks requires a \$200.00 charge plus actual shipping costs to and from the customer. If the repair is greater than \$200.00, an estimate is issued to the customer for authorization of repair. If no authorization is obtained, or the product is deemed not repairable, Transition Networks will retain the \$200.00 service charge and return the product to the customer not repaired. Non-warranted products that are repaired by Transition Networks for a fee will carry a 180-day limited warranty. All warranty claims are subject to the restrictions and conventions set forth by this document.

Transition Networks reserves the right to charge a \$50 fee for all testing and shipping incurred, if after testing, a return is classified as "No Problem Found."

THIS WARRANTY IS YOUR ONLY REMEDY. NO OTHER WARRANTIES, SUCH AS FITNESS FOR A PARTICULAR PURPOSE, ARE EXPRESSED OR IMPLIED. TRANSITION NETWORKS IS NOT LIABLE FOR ANY SPECIAL, INDIRECT, INCIDENTAL OR CONSEQUENTIAL DAMAGES OR LOSSES, INCLUDING LOSS OF DATA, ARISING FROM ANY CAUSE OR THEORY. AUTHORIZED RESELLERS ARE NOT AUTHORIZED TO EXTEND ANY DIFFERENT WARRANTY ON TRANSITION NETWORKS'S BEHALF.

Contact Us

Technical Support: Technical support is available 24-hours a day

US and Canada: 1-800-260-1312

International: 00-1-952-941-7600

Main Office

tel: +1.952.941.7600 | toll free: 1.800.526.9267 | fax: 952.941.2322

sales@transition.com | techsupport@transition.com | customerservice@transition.com

Address

Transition Networks

10900 Red Circle Drive

Minnetonka, MN 55343, U.S.A.

Web: <https://www.transition.com>



Transition Networks

10900 Red Circle Drive

Minnetonka, MN 55343 USA

tel: +1.952.941.7600 | toll free: 1.800.526.9267 | fax: 952.941.2322

Copyright© 2018-2021 Transition Networks. All rights reserved. Printed in the U.S.A.

SISTG10xx-211-LRT-B Install Guide, 33749 Rev. C