

EMB Electromechanical Bar

Mechanical activation for electronic lock release in a reliable, durable exit bar



Use the Electromechanical Bar (EMB) on electronically locked, non-fire-rated doors or as an initiate device for a delayed egress timer.

Pressing the bar activates internal mechanical switches that release the lock. Optional waterproof switches are available, which allow the EMB to function in protected outdoor applications. Meets "no special tools or knowledge" criteria for code requirements.

Features

Standard Features

- Low profile design requires only 1/4" [6.35mm] movement for activation
- Can be field cut to accommodate non-standard openings up to 48" [1219mm]
- Uses same mounting pattern as the TSB and DSB
- Direct retrofit for some competitor footprints
- Mechanical action activates a DPDT relay
- 5A rated output to allow free egress or initiate an exit delay timer
- Redundant switches ensure reliable, fault-tolerant operation
- All metal construction
- 16 ft. [4.8m] 22 AWG 6 conductor cable and armored door cord included
- MagnaCare® lifetime replacement, no-fault, no questions asked warranty

Optional Features

- **36** 36" [914mm] Length
- **42** 42" [1,067mm] Length
- **48** 48" [1,219mm] Length
- **W** Weather-resistant upgrade
- Cover plates for retrofit of competitor products (TCP-BK-CL)



Specifications

Certifications

- UL 294 Listed
- CAN/ULC -S533

Electrical

- Max current 1.5A at 30VDC

Environmental

- Operating Temperature:
-4° to 185° F [-20° to 85° C]
- Indoor operation
- Optional weather-resistant switches

Shipping Weight

- 7 lbs [3.18kg] to 9 lbs [4.08kg]
depending on length



TCP covers unwanted holes from previously installed exit bars, strengthens the mounting area and provides a clean look.

Dimensions

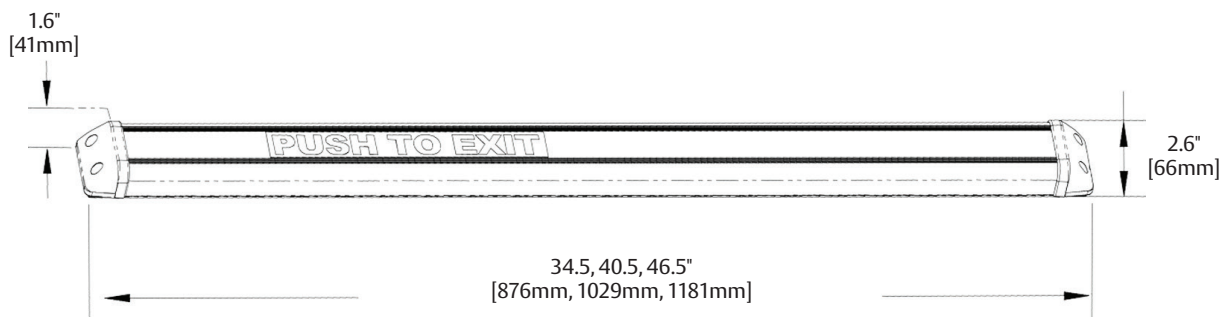

How to Order

CONNECTOR STYLE	FINISH	BAR LENGTH
EMB	- CL	- 42
EMB Electromechanical Bar	BK Black Anodized	(blank) 36" Length
WEMB Weather Resistant Electromechanical Bar	CL Clear Anodized	42" 42" Length
		48" 48" Length

NOTE: Not every combination above is possible. Please contact the factory if you need a combination of features not listed on this page.