

## INSTALLATION INSTRUCTIONS

WHEELOCK ELUXA TYPE 4X/3R WEATHERPROOF STROBE,  
WITH PRE-WIRE/PRE-TEST  
WALL/CEILING MOUNT (BLUE, GREEN OR RED LENS)

Use this product according to this instruction manual. Please keep this instruction manual for future reference.

### GENERAL:

The Wheelock Eluxa weatherproof series EL4XSTB/EL3RSTB (Blue), EL4XSTG/EL3RSTG (Green) and EL4XSTR/EL3RSTR (Red) strobe appliances are designed for easy installation with a pre-wire capable EL4XBB back box or EL3RMP mounting plate. Eluxa 4X/3R strobes are designed for 24V operation. All Eluxa 4X/3R models are for [indoor/outdoor use](#) and [wall or ceiling mount](#).

The Wheelock Eluxa 4X/3R series meets NFPA 2016 20 millisecond light pulse duration code requirements. In addition, the Wheelock Eluxa and LED3 product lines have been UL/ULC listed as compatible with all Fire Alarm Control Panels (FACP) and accessories that have been determined to be compatible with Wheelock model RSS Strobe based products including the RSS, ASWP, CH, E, EH, ET, ST, HS, MT, S8, SA, STH and Z Series. The maximum number of Eluxa devices per NAC is determined by dividing the maximum current rating of the FACP NAC by the total current rating of one Eluxa device, with a maximum of 105 Eluxa (or LED3) devices per NAC. Refer to FACP installation instructions for more detail. The Wheelock Eluxa Series and Exceder LED3 Series strobes may be installed in the same notification zone and field of view with any RSS Strobe based product.

Wheelock Eluxa 4X/3R Multi-Candela Strobes can provide a non-synchronized strobe appliance when connected directly to a Fire Alarm Control Panel (FACP), or provide a synchronized strobe appliance when used in conjunction with an FACP that incorporates the Cooper Wheelock sync protocol, a Dual Sync Module (DSM), or the Wheelock Power Supply.

**CAUTION:** Do not change factory applied finishes. "DO NOT PAINT".

**ATTENTION:** Ne pas modifier les finitions appliquées en usine. "NE PAS PEINTURER"

**IMPORTANT:** PLEASE READ THESE INSTRUCTIONS CAREFULLY. FAILURE TO COMPLY WITH ANY OF THE FOLLOWING INSTRUCTIONS COULD RESULT IN IMPROPER APPLICATION, INSTALLATION AND/OR OPERATION OF THESE PRODUCTS IN AN EMERGENCY SITUATION, WHICH COULD RESULT IN PROPERTY DAMAGE AND SERIOUS INJURY OR DEATH TO YOU AND/OR OTHERS.

### SPECIFICATIONS:

Table 1: Specifications

Models*	EL4XSTB (Blue), EL4XSTG (Green), EL4XSTR (Red) EL3RSTB (Blue), EL3RSTG (Green), EL3RSTR (Red)
Agency	UL1638, UL1971, ULC-526
Input Voltage	DC or FWR, 24V Regulated, 16 to 33V (All models)
Light Output On-Axis See Note 1,4	EL4X/3RSTB (Blue): 15, 30, 75, 95, 135, 150cd (field selectable) EL4X/3RSTG (Green): 15, 30, 60, 75, 115, 125cd (field selectable) EL4X/3RSTR (Red): 10, 20, 40, 50, 75, 80cd (field selectable)
NAC Characteristics	Max. line resistance: 35Ω
Environmental	Indoor/Outdoor Use, -40° C to 66° C (-40° F to 150° F) 95% R.H.

\*Prefix "ELWP" indicates "Subassembly". Requires EL4XBB surface box or EL3RMP mounting plate for installation.

Table 2: Eluxa 4X/3R Strobe Current Ratings (AMPS)\*\*

EL4X/3RSTB (Blue)	15cd	30cd	75cd	95cd	135cd	150cd
EL4X/3RSTG (Green)	15cd	30cd	60cd	75cd	115cd	125cd
EL4X/3RSTR (Red)	10cd	20cd	40cd	50cd	75cd	80cd
DC	0.026	0.038	0.070	0.097	0.179	0.206
FWR	0.034	0.053	0.098	0.137	0.235	0.308

\*\* Strobe setting will determine the current draw of the product.

When calculating the total current, use Table 2 to determine the highest value of "RMS Current" for an individual appliance, then multiply these values by the total number of appliances; be sure to add the currents for any other appliances powered by the same source and include any required safety factors.

Make sure that the total RMS current required by all appliances that are connected to the system's PRIMARY and SECONDARY power sources, NAC circuits, DSM Sync Modules or Wheelock Power Supplies does not exceed the power sources' rated capacity or the current ratings of any fuses on the circuits to which these appliances are wired.

Check the minimum and maximum output of the power supply and standby battery, and subtract the voltage drop from the circuit wiring resistance to determine the applied voltage to the appliance.

### WIRING DIAGRAMS:

Figure 1: EL4X/3R STROBE

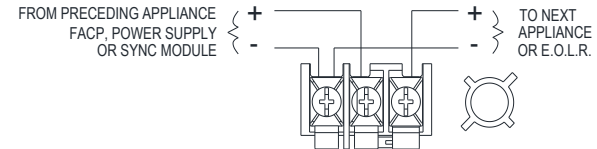

\*Refer to Dual Sync Module instruction sheets DSM (P83177) or Wheelock's Power Supplies for additional information.

Figure 2:



1. This model has in-out wiring terminals that accept #12 to #18 American Wire Gauge (AWG) wires at each screw terminal. Strip leads 3/8 inches and connect to screw terminals.
2. Break all in-out wire runs on supervised circuits to assure integrity of circuit supervision as shown in Figure 2. The polarity shown in the wiring diagrams is for operation of the appliances. The polarity is reversed by the FACP during supervision.

### NOTES:

1. The strobe will produce 1 flash per second over the "Regulated Voltage" range.
2. Strobe is not designed to be used on coded systems in which the applied voltage is cycled on and off.
3. The maximum number of Eluxa or LED3 strobes on a single notification appliance circuit shall not exceed 105.
4. **Blue, Green, or Red Strobes are Private Mode Only**, and shall not be used as Visual Public Mode alarm notification.
5. These appliances are UL Listed as "Regulated". They are intended to be used with FACPs whose notification circuits are UL Listed as "Regulated." Refer to the FACP instructions or the Wheelock Strobe Compatibility Data Sheet (P85328) for special application and strobe synchronization compatibility.
6. These appliances were tested to the regulated voltage limits of 16.0-33.0 Volts. Do not apply voltage outside of this range. Check the minimum and maximum output of the power supply and standby battery and subtract the voltage drop from the circuit wiring resistance to determine the applied voltage to the strobes. The max wire impedance between strobes shall not exceed 35 ohms.
7. Make sure that the total RMS current required by all appliances that are connected to the system's primary and secondary power sources, notification appliance circuits, DSM sync modules, or Wheelock power supplies does not exceed the power sources rated capacity or the current ratings of any fuses on the circuits to which these appliances are wired.
8. The effect of shipping and storage temperatures shall not adversely affect the performance of the appliance when it is stored in the original cartons and not subjected to misuse or abuse.

**SETTINGS:** To set candela, slide the selector switch to the desired setting. See Figure 3.

**Figure 3: Settings - Set from rear (PCB Side)**  
Factory Setting is 15cd or 10cd (Red).

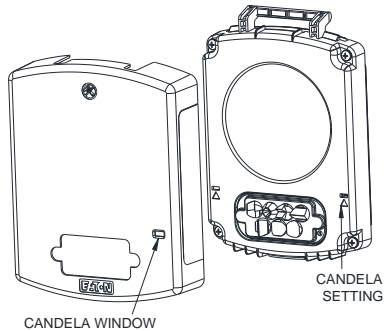

Strobe device has only one mounting orientation. LED light element should be oriented toward the floor

NFPA 72/ANSI 117.1 provide means for determining equivalent illumination using fewer, higher intensity strobes within the same area.

**Figure 4: Light Distribution**  
(Expected % of Rated Candela)

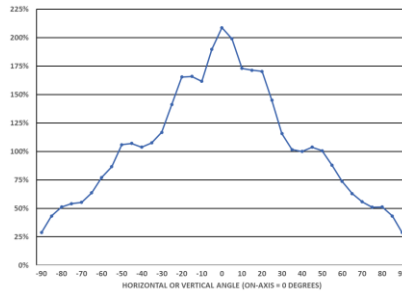

**MOUNTING OPTIONS:**

The following figures (A and B) show the maximum number of field wires (conductors) that can enter the backbox used with each mounting option. If these limits are exceeded, there may be insufficient space in the backbox to accommodate the field wires and stresses from the wires could damage the product.

Check that the installed product will have sufficient clearance and wiring room prior to installing backboxes and conduit, especially if sheathed multiconductor cable or 3/4" conduit fittings are used.

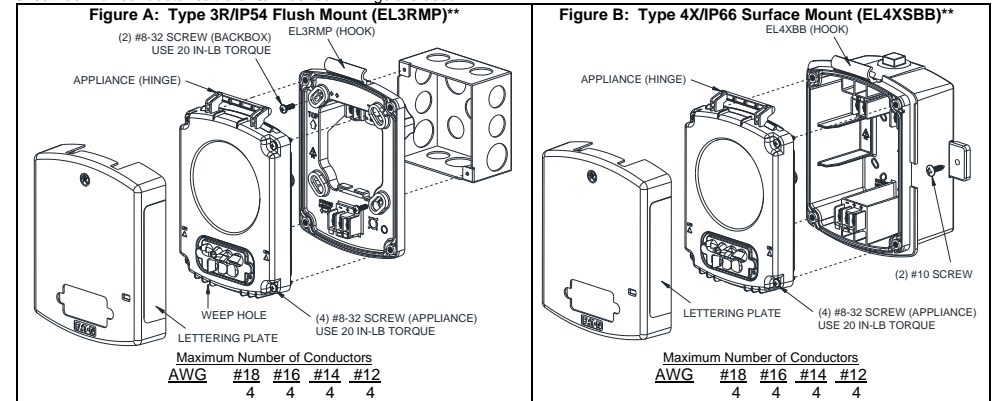

**All installations shall be in accordance with:**

- 1) In the United States, the National Electrical Code, NFPA 70, and the National Fire Alarm and Signaling Code, NFPA 72.
- 2) In Canada, CSA C22.1, Canadian Electrical Code, Part I, Safety Standard for Electrical Installations, Section 32; and the Canadian Standard for the Installation of Fire Alarm Systems ULC-524.

**MOUNTING PROCEDURES:**

**Important: Do not fully back out terminal screws. Do not over tighten screws or terminals. Excessive torque may affect operation. When using power tools, ensure the torque is set to the lowest setting available.**

1. **Preliminary Info:** Use EL3RMP for flush mount, or EL4XBB for surface mount. Screws are provided for installation. Conduit entrances to the backbox should be selected to provide sufficient wiring clearance for the installed product. Do not pass additional wires (used for other than the signaling appliance) through the backbox. Such additional wires could result in insufficient wiring space for the signaling appliance.
2. **A: Install the EL3RMP Mounting Plate** on the 4" square 2-1/8" deep backbox (flush mount only) using 8-32 screws. EL3RMP is suitable for mounting to brick, ceramic tile, concrete and masonry surfaces. For Type 3R/IP54 wall mount applications, a weep hole knock-out is provided below the strobe. See Figure A. To open the weep hole knock-out (1/8" dia.), use a small screwdriver.  
**B: Install the EL4XBB Back Box** – Two external mounting tabs must be used along with two #10 screws (provided). See Figure 6. Mounting hole spacing is 5-9/16". Conduit fittings must be rated Type 4X/IP66 and UL certified. Installer must ensure ground continuity when metallic conduit is used. Teflon tape must be used on all conduit fittings. 3/4" NPT Plugs must be installed using Teflon tape and O-Ring (provided). Secure NPT plug and conduit fitting with **26in-lb torque**.  
Note: "HOOK" must be on top for wall mounting.
3. **Pre-Wire: Connect field wires to terminals** on EL3RMP or EL4XBB (reference Figure 1 and 2). Use care and proper techniques to position the field wires in the backbox so that they use minimum space and produce minimum stress on the product. This is especially important for stiff, heavy gauge wires and wires with thick insulation or sheathing. When terminating field wires, do not use more lead length than required. Excess lead length could result in insufficient wiring space for the signaling appliance.
4. **Pre-Test: EL3RMP and EL4XBB contain a SHUNT** between adjacent "+" terminals to facilitate testing before device is attached.  
Note: Shunt will open permanently when device is installed.
5. **Verify appliance settings** are correct for your application. Settings are shown in Figure 3. Factory setting is 15cd or 10cd (Red).
6. **Place the appliance "HINGE"** over the "HOOK" on the EL3RMP or EL4XBB. Verify the appliance is aligned to the EL3RMP/EL4XBB, then secure with four #8-32 screws attached to appliance with **20in-lb torque**. Verify the gasket is seated correctly and not "pinched".
7. **Align grille with lettering plates** to the appliance and snap in place. (Note: Insert letter plates with "T" tab down on strobe/logo-side).
8. **Recommend** applying outdoor rated silicone to all outdoor Type 4X/3R installations.
9. **To remove** the appliance grille, insert a small flat-bladed screwdriver into the bottom opening to release snap as shown in Figure 5. Then "pull" to remove the cover/grille.

NOTE: Final acceptance is subject to Authorities Having Jurisdiction.

Check the installation instructions of the manufacturers of other equipment used in the system for any guidelines or restrictions on wiring and/or locating Notification Appliance Circuits (NAC) and notification appliances. Some system communication circuits and/or audio circuits, for example, may require special precautions to assure immunity from electrical noise (e.g. audio crosstalk).

This equipment has been tested and found to comply with the limits for a Class A digital device, pursuant to part 15 of the FCC Rules. These limits are designed to provide reasonable protection against harmful interference when the equipment is operated in a commercial environment. This equipment generates, uses, and can radiate radio frequency energy and, if not installed and used in accordance with the instruction manual, may cause harmful interference to radio communications. Operation of this equipment in a residential area is likely to cause harmful interference in which case the user will be required to correct the interference at his own expense.

This Class A digital apparatus meets all requirements of the Canadian Interference-Causing Equipment Regulations. Cet appareil numérique de la classe A respecte toutes les exigences du Règlement sur le matériel brouilleur du Canada.

Any material extrapolated from this document or from Cooper Wheelock manuals or other documents describing the product for use in promotional or advertising claims, or for any other use, including description of the product's application, operation, installation and testing is used at the sole risk of the user and Cooper Wheelock will not have any liability for such use. IN NO CASE WILL SELLER'S LIABILITY EXCEED THE PURCHASE PRICE PAID FOR A PRODUCT.

**Figure 5: Cover/Grille Removal \*\***

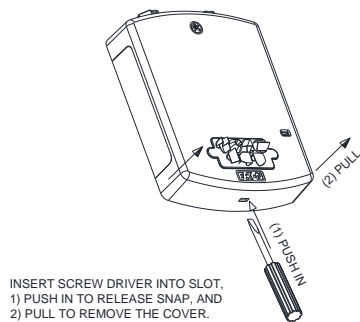

\*\*Refer to Instruction sheet P85820 for additional information on EL4XBB surface box and EL3RMP mounting plate.

**Figure 6: Type 4X/IP66 Surface BackBox (EL4XBB)\*\***

